

**Some pages of this thesis may have been removed for copyright restrictions.**

If you have discovered material in Aston Research Explorer which is unlawful e.g. breaches copyright, (either yours or that of a third party) or any other law, including but not limited to those relating to patent, trademark, confidentiality, data protection, obscenity, defamation, libel, then please read our [Takedown policy](#) and contact the service immediately ([openaccess@aston.ac.uk](mailto:openaccess@aston.ac.uk))

MECHANOCHEMICAL SYNTHESIS AND EVALUATION OF

RUBBER-THERMOPLASTIC POLYMER BLENDS

BY

EDDY JUNADI AMIR

A thesis submitted for the Degree of  
Doctor of Philosophy of the University  
of Aston in Birmingham

March, 1984

## SUMMARY

THE UNIVERSITY OF ASTON IN BIRMINGHAM

### MECHANOCHEMICAL SYNTHESIS AND EVALUATION OF RUBBER-THERMOPLASTIC POLYMER BLENDS

EDDY JUNADI AMIR

Submitted for the Degree of Ph.D

March 1984

Natural rubber-polypropylene (NR/PP) blends have been studied under different conditions vis. processing parameters, mixer and at different ratios. It has been found that the requirement of a typical thermoplastic rubber can be achieved at a ratio of NR to PP of 60:40. It was found that chemical interaction between the two phases, which may take place as a result of mechanochemical reaction, could not be achieved, and the thermoplastic rubber produced was essentially a physical blend.

The role of free-radical initiators such as benzoyl and dicumyl peroxide, on the behaviour of NR/PP(60/40) blends was investigated. It was shown that dicumyl peroxide was more effective than benzoyl peroxide in improving mechanical properties of blends. Again no chemical reaction between the two phases could be achieved. Crosslinking reaction in the rubber phase may be responsible for the improvement in tensile properties in the presence of dicumyl peroxide. Ethylene-propylene terpolymer (EPDM) was also used in an attempt to improve the adhesion between the two phases. However, the results shown in this work confirm that no such interaction takes place in the presence of EPDM and the overall properties of the blend is lower than in the case of dicumyl peroxide.

The performance of different ratios of natural rubber-polypropylene (60/40) composition as a solid phase dispersant (SPD) in polypropylene-polyethylene (1:1) blends was investigated. The behaviour of the above system was compared with that of EPDM when used as SPD in the same blends; NR/PP offers better tensile properties while EPDM contributes mainly to impact performance of the PP/PE blends. Photo-oxidative stability of these blends in the presence of NR/PP and EPDM was also investigated. In general, EPDM system offered better overall stability. However, in both cases (i.e., NR/PP and EPDM systems), a synergistic system based on a combination of peroxide decomposer, UV-absorber/screen and free-radical scavenger e.g., HOBP/Cyasorb 1084/Irganox 1076, was shown to be the best photo-antioxidant system.

The effect of partial replacement of fresh natural rubber by reclaim rubber (RR) on the properties of NR/PP (60/40) blends was studied. It was found that properties of natural rubber-polypropylene (60/40) blend could be maintained by replacing up to half of the fresh rubber by reclaim rubber. The behaviour of this composition (i.e., (NR/RR)/PP at a ratio of 30:30:40) as a solid phase dispersant in PP/PE(1:1) blend was investigated. It was shown that although this system offers a better photo-oxidative stability than a blend which is based entirely on fresh rubber, its impact performance is inferior to blends containing either NR/PP (i.e., no RR) or EPDM as SPD's.

#### KEY WORDS

POLYMER BLENDS  
NATURAL RUBBER  
THERMOPLASTIC RUBBER

SOLID PHASE DISPERSANT  
PHOTO-OXIDATION

## Acknowledgments

I wish to acknowledge the invaluable supervision and guidance of my supervisor Dr S Al-Malaika throughout this project. My thanks are due also to Professor G Scott and Mr J E Stuckey for their encouragement and interest.

I am deeply indebted to the Indonesian Government for the financial award which enables me to complete this work, without which it would be totally impossible.

I sincerely thank the 'Balai Penelitian Perkebunan Bogor' (Research Institute for Estate Crops-Bogor) for the study-leave and also for their support and encouragement.

My thanks are also due to all the technical staff of the Polymer Group for their kind assistance and co-operation.

I also wish to extend my sincere appreciation to Mrs L Ludlow for her patience in typing this thesis.

Declaration

I hereby declare that the work described in this thesis was carried out at the University of Aston in Birmingham between October 1980 and October 1983.

It has been done independently and submitted for no other degree.

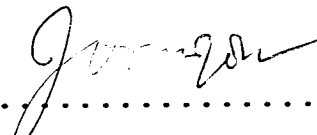
  
.....  
EDDY JUNADI AMIR

March 1984

Dedication

This is dedicated to my wife Ann and my children,  
Agus and Andi.

LIST OF FIGURES

<u>Figure</u>	<u>Page</u>	<u>Figure</u>	<u>Page</u>
1. 1	7	3.15	98
1. 2	9	3.16	99
1. 3	15	3.17	100
2. 1	44	3.18	101
2. 2	47	3.19	102
2. 3	49	3.20	103
2. 4	52	3.21	104
2. 5	54	3.22	105
2. 6	57	3.23	106
2. 7	58	3.24	107
2. 8	61	3.25	108
2. 9	62	3.26	109
3. 1	84	3.27	110
3. 2	85	3.28	111
3. 3	86	3.29	112
3. 4	87	3.30	113
3. 5	88	3.31	114
3. 6	89	3.32	115
3. 7	90	3.33	116
3. 8	91	3.34	117
3. 9	92	3.35	118
3.10	93	3.36	119
3.11	94	3.37	120
3.12	95	3.38	121
3.13	96	3.39	122
3.14	97	3.40	123

<u>Figure</u>	<u>Page</u>	<u>Figure</u>	<u>Page</u>
3.41	124	4.18	168
3.42	125	4.19	169
3.43	126	4.20	170
3.44	127	4.21	171
3.45	128	4.22	172
3.46	129	5. 1	207
3.47	130	5. 2	208
3.48	131	5. 3	209
4. 1	151	5. 4	210
4. 2	152	5. 5	211
4. 3	153	5. 6	212
4. 4	154	5. 7	213
4. 5	155	5. 8	214
4. 6	156	5. 9	215
4. 7	157	5.10	216
4. 8	158	5.11	217
4. 9	159	5.12	218
4.10	160	5.13	219
4.11	161	5.14	220
4.12	162	5.15	221
4.13	163	5.16	222
4.14	164	5.17	223
4.15	165	5.18	224
4.16	166	5.19	225
4.17	167	5.20	226



<u>Figure</u>	<u>Page</u>
5.21	227
5.22	228
5.23	229
5.24	230
5.25	231
5.26	232
6. 1	244
6. 2	245
6. 3	246
6. 4	247
6. 5	248
6. 6	249
6. 7	250
6. 8	251
6. 9	252
6.10	253
6.11	254
6.12	255
6.13	256
6.14	257
6.15	258
6.16	259
6.17	260
6.18	261

LIST OF DIAGRAMS

<u>Diagram</u>	<u>Page</u>
4. 1	133
4. 2	135
5. 1	175
5. 2	176
5. 3	180
5. 4	181
5. 5	182
5. 6	183
5. 7	184
6. 1	234
6. 2	236

## LIST OF TABLES

<u>Table</u>	<u>Page</u>
1.1	11
1.2	13
1.3	17
1.4	20
1.5	31-32
1.6	33
2.1	40
2.2	46
3.1	81
4.1	141
4.2	147
5.1	179
5.2	187
5.3	197
5.4	198
5.5	200

LIST OF PLATES

<u>Plate</u>	<u>Page</u>
5.1	190
5.2	190
5.3	191
5.4	191
5.5	192
5.6	192

## LIST OF ABBREVIATIONS

NR	Natural Rubber
PP	Polypropylene
PE	Polyethylene
RR	Reclaim Rubber
EPDM	Ethylene-propylene terpolymer
GPC	Gel Permeation Chromatography
EB	Elongation at Break
SEM	Scanning Electron Microscopy
Tan	Mechanical Damping
T.S.	Tensile Strength
Y.S.	Yield Strength
SPD	Solid Phase Dispersant
UV	Ultra Violet
Tg	Glass Transition Temperature

<u>LIST OF CONTENTS</u>		<u>Page</u>
Summary		ii
Acknowledgements		iii
Declaration		iv
Dedication		v
List of Figures		vi
List of Diagrams		ix
List of Tables		x
List of Plates		xi
List of Abbreviations		xii
<u>CHAPTER I</u>	INTRODUCTION	
1.0	Introduction	1
1.1	Structure and Characteristics of Thermoplastic Rubbers	2
1.2	Developments in Thermoplastic Rubbers	5
1.3	Developments in Thermoplastic Natural Rubbers (TPNR)	22
1.3.1.	Graft Copolymerisation of Natural Rubber with Hard Thermoplastic	22
1.3.2.	Mechanical Blending of Natural Rubber and Polyolefins	29
1.3.3.	Vulcanisation of Natural Rubber with Thermolabile Crosslinks	30
<u>CHAPTER 2</u>	EXPERIMENTAL	
2.1.	Materials	36
2.2.	Processing and Sample Preparations	36

	<u>Page</u>
2.3.	Testing for Compression Moulded Samples 38
2.3.1.	Tensile Properties Measurements 38
2.3.2.	Dynamic Mechanical Properties Measurements 39
2.3.3.	Determination of Binding of Natural Rubber 41
2.3.4.	Determination of Gel Content 41
2.3.5.	Measurement of Melt Flow Index 42
2.3.6.	Determination of Melt Rheology 43
2.3.7.	Ultra-Violet Irradiation 46
2.3.8.	Infra-red Spectroscopy 46
2.3.9.	Measurement of Impact Strength 48
2.3.10	Gel Permeation Chromatography (GPC) 50
2.3.11.	Measurement of Glass Transition Temperatures (T <sub>g</sub> ) 51
2.4.	Testing for Injection Moulded Samples 55
2.4.1.	Tensile Properties Test 56
2.4.2.	Flexural Properties Test 56
2.4.3.	Measurement of Dynamic Mechanical Properties 56
2.4.4.	Charpy Impact Test 59
2.4.5.	Scanning Electron Microscopy 60
2.4.6.	Oven Ageing 63

	<u>Page</u>
<u>CHAPTER 3</u>	
PREPARATION OF NATURAL RUBBER-POLY- PROPYLENE BLENDS BY MECHANICAL BLENDING	
3.1. Objectives	64
3.2. Results and Discussion	66
3.2.1. Optimisation	66
3.2.2. Effect of Free Radical Initiator on the Properties of NR/PP Blends	70
3.2.2.1. Processing by Method A	70
3.2.2.2. Processing by Method B	76
3.2.3. Effect of Ethylene-propylene Rubber (EPDM) on the Properties of Natural Rubber-polypropylene Blends	82
<u>CHAPTER 4</u>	
EFFECTS OF CARBON BLACK AND TYPE OF MIXER ON THE PROPERTIES OF NR/PP BLENDS	
4.1. Objective	132
4.2. Results and Discussion	136
4.2.1. Effect of Carbon Black on the Pro- perties of NR/PP (60/40) Blends	136
4.2.2. Effect of Type of Mixer on the Pro- perties of NR/PP Blends	140
4.2.2.1. Compression Moulded Films	140
a. Physical Properties	
b. Thermal Degradative Stability of the Blends	
c. Photo-oxidative Stability	



		<u>Page</u>
4.2.2.2.	Injection Moulded Samples	146
	a. Physical Properties	
	b. Re-injection Moulding and Oven- Ageing	
<u>CHAPTER 5</u>	<u>EFFECT OF NR/PP COMPOSITION AS SOLID PHASE DISPERSANT ON THE PROPERTIES OF PP/PE BLENDS</u>	
5.1.	Objective	173
5.2.	Results and Discussions	178
5.2.1.	Effect of Concentration of SPD on the Mechanical Properties of Ternary Blend PP/PESPD (40:40:20)	178
5.2.1.1.	Compression Moulded Samples	178
5.2.1.2.	Injection Moulded Samples	186
5.2.2.	Effect of SPD on the Photo-oxidative Stability of PP/PE Blends	193
5.2.3.	Effect of Stabilisers on Properties of PP/PE/SPD (40:40:20) Blends	196
5.2.3.1.	Effect of Stabilisers on the Ini- tial Properties of PP/PE/SPD (40: 40:20) Blends	196
5.2.3.2.	Effect of Stabilisers on the Photo- Oxidative Stability of PP/PE/SPD (40:40:20) Blends	201

	<u>Page</u>
<u>CHAPTER 6</u>	
	PREPARATION OF NATURAL RUBBER-POLY- PROPYLENE BLENDS USING RECLAIM RUBBER AND ITS USAGE AS SOLID PHASE DISPER- SANT IN PP/PE BLENDS
6.1.	Objective 233
6.2.	Results and Discussions 235
6.2.1.	Preparation of NR/PP Blends Con- 235 taining Reclaim Rubber
6.2.1.1.	Effect of Reclaim Rubber on the Pro- 235 perties of NR/PP Blends
6.2.1.2.	Effect of Dicumyl Peroxide on the 237 Properties of (NR/RR)/PP Blends
6.2.1.3.	Thermal-oxidative Stability of NR/PP 238 Blends Containing 50/50 NR/RR
6.2.2.	Effect of (NR/RR)/PP as Solid Phase Dispersant (SPD) on Properties of PP/PE Blends
6.2.3.	Photo-oxidative Stability of PP/PE/SPD 242 Ternary Blends Containing Reclaim Rubber
<u>CHAPTER 7</u>	
	CONCLUSIONS AND SUGGESTIONS FOR FURTHER WORK
7.1.	Conclusions 262
7.2.	Suggestions for Further Work 265
APPENDICES	268
REFERENCES	271

CHAPTER ONE

INTRODUCTION

## 1.0 Introduction

Thermoplastic rubbers exhibit dual behaviour in that they can be processed at elevated temperatures as thermoplastic materials while performing as vulcanised rubber during service<sup>(1,2)</sup>. These materials are becoming increasingly attractive because they bridge the gap between rubber and thermoplastic<sup>(3)</sup>, and range from rubberlike thermoplastics to high-impact thermoplastics.

The commercial advantages of thermoplastic rubbers over conventional rubbers lie in their processability. Thermoplastic rubbers can be processed on machines normally used for thermoplastic processing and require no vulcanisation<sup>(4,5)</sup>, therefore the mixing process is simplified. Moreover, in the absence of vulcanisation, the number of additives necessary is considerably reduced. These processing advantages result in savings in time, energy consumption and capital costs of machinery. Furthermore, material wastage is reduced since scrap and reject can be recycled. Thermoplastic rubbers also give higher throughput in injection moulding and extrusion than thermosetting ones. With these advantages, thermoplastic rubbers are currently finding markets in some application where vulcanised rubbers have been traditionally used, and plastic converters are also using them for products with better performance than can be obtained with general purpose thermoplastics. At a time of general decline in world-wide consumption of both

rubber and plastic, the demand for thermoplastic rubbers is rising<sup>(6)</sup>. This promising feature has also been enhanced by the increasing price of oil and the spectacular changes in automotive industry where the saving in weight is of paramount importance<sup>(7)</sup>.

### 1.1 Structure and Characteristics of Thermoplastic Rubbers

In general, thermoplastic rubbers can be divided into two categories based on their structures and the method of their processing. The first covers a wide range of materials produced by copolymerisation processes and contains both rubbery and hard segments. This is characterised by the presence of chemical bonding between those segments. The hard segment is acting as a well-bonded reinforcing filler<sup>(8,9)</sup> and as a crosslink<sup>(10-16)</sup> that will prevent chain slippage on application of stress and will disappear when heated above a certain temperature which is, nevertheless, below the decomposition temperature of the polymer<sup>(17)</sup>.

The second category of thermoplastic rubbers is obtained by mechanical blending of a rubber with a glassy or crystalline polymer, in which the hard polymer becomes dispersed in the rubbery phase and will form domains which act as "pseudo-crosslinks" to provide dimensional stability and recovery after mechanical deflection<sup>(18,19)</sup>. Reinforcement is provided by these hard domains while the amorphous and rubbery phase offer flexibility<sup>(2)</sup>. The hard domain will

disappear and the material flow at elevated temperatures as thermoplastics. The properties of this category would be expected to be dependent on the molecular weight and structure of both rubber and thermoplastic phases, the ratio of rubber to thermoplastic, and additives used in its preparation<sup>(1,17)</sup>.

The characteristic of the above categories lies, therefore, in the presence of crosslinks and both hard and rubbery phases. Crosslinks may be in the form of truly chemical bonding or be just physical crosslinks. Both types of crosslinks have been described as "heat fugitive"<sup>(20)</sup>. A basic requirement for thermoplastic rubber, therefore, is the transitory formation of the crosslinks at ambient temperature and their loss at elevated temperature. There are many approaches by which this basic requirement may be achieved, such as:

- (i) Ionic crosslinks. Here, the chemical bonding is ionic. Du Pont ionomers constitute a typical commercial example. These are copolymers of ethylene with a few percent of a second monomer such as  $\alpha, \beta$ -carboxylic acid. When the material is blended with metal salts, ionic crosslinks are formed. These are strong at room temperature but disappear on heating<sup>(21)</sup>. The ionic crosslinks have also been used in butadiene-methacrylate acid copolymer neutralised with metal salts<sup>(10)</sup>.

- (ii) Hydrogen bonding. This type of bonding occurs with some types of polyurethane materials. The crystalline or glassy blocks of polyurethane thermoplastic rubbers are physically bonded by hydrogen bonding to form hard domains dispersed in the rubbery phase<sup>(11)</sup>.
- (iii) Crystalline block copolymers. The crystalline phase in polyester thermoplastic rubbers acts as thermally labile multiple crosslinks<sup>(12,13)</sup>.
- (iv) Glassy block copolymers. Blocks of glassy polymers can act as crosslinks between rubbery segments of different molecules. This type of link occurs with styrene-butadiene-styrene block copolymer, styrene-isoprene-styrene block copolymer and other styrenic block copolymers<sup>(14,15,16)</sup>. The styrenic-rich spherical domains which are embedded in a continuous elastomer-rich rubbery matrix<sup>(22)</sup> provide a sort of physical multiple crosslink at the chain ends and also act as pseudo-reinforcing filler. If the material is heated above the T<sub>g</sub> of the styrenic block, the physical crosslinking imparted by these glassy domains disappear so that the material can flow like a thermoplastic.
- (v) Physical blend of rubbers with crystalline thermoplastic. In this type of "heat fugitive crosslinks", the only probability of tying or linking the rubber

is via a pseudo-crosslink due to the presence of crystalline thermo-plastic dispersed in the rubbery matrix. Contribution of true chemical bonding, such as grafting between two phases, has been found to be only little<sup>(23)</sup>. This approach of achieving the thermoplastic rubber behaviour has an important role in rubber technology. Thermoplastic rubber materials involve mainly blends of olefin polymers and copolymer<sup>(24)</sup>, polyethylene and butyl rubber, polyolefin and natural rubber<sup>(2)</sup>.

## 1.2 Developments in Thermoplastic Rubbers

The development of thermoplastic rubbers dates back to 1958, when Bayer in Germany developed polyurethanes which were the first major elastomers that can be processed by thermoplastic methods<sup>(25,26)</sup>.

Polyurethanes are formed as a reaction product of a diisocyanate with hydroxyl terminated polyether or polyester polyol and a low molecular weight glycol chain extender. The polyol forms the amorphous soft segment of the polymer. The glycol, which is a short chain hydroxyl terminated diol, provides the strongly hydrogen bonded hard segment of the polymer<sup>(27,28)</sup>. The basic reaction is described in Scheme 1.1, where  $\text{HO}\sim\text{R}'\sim\text{OH}$  and  $\text{HO}-\text{R}''-\text{OH}$  represent long chain aliphatic polyester or polyether and short chain diol e.g., 1,4 butanediol, respectively.



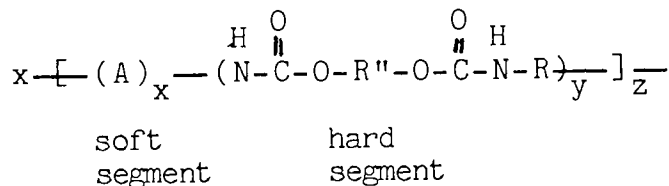
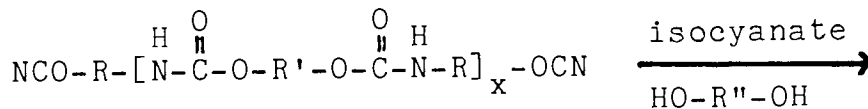
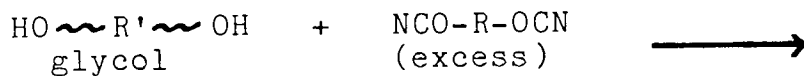

Scheme 1.1 Chemical formation of a thermoplastic polyurethane<sup>(29)</sup>

A is diisocyanate-polyol reaction product. The polyurethane primary chains, therefore, consist of alternating soft and hard segments which are inherently incompatible and form microphase segregation<sup>(30,31)</sup>. This is represented schematically in Fig 1.1. The semi-ordered regions of hard segments produce heat-fugitive crosslinks<sup>(11)</sup> which are necessary for the development of strength, and the amorphous flexible soft segments give the copolymer its elastomeric nature<sup>(32)</sup>. Evidence for the existence of the two phases has come from X-ray diffraction<sup>(33-36)</sup>, electron microscopy<sup>(37)</sup> and infra-red dichroism<sup>(38)</sup>. Dynamic mechanical studies<sup>(39,40)</sup> and differential scanning calorimetry<sup>(41)</sup> have shown the existence of a glass transition in the soft segments, as well as the melting (or softening) of the hard segments.

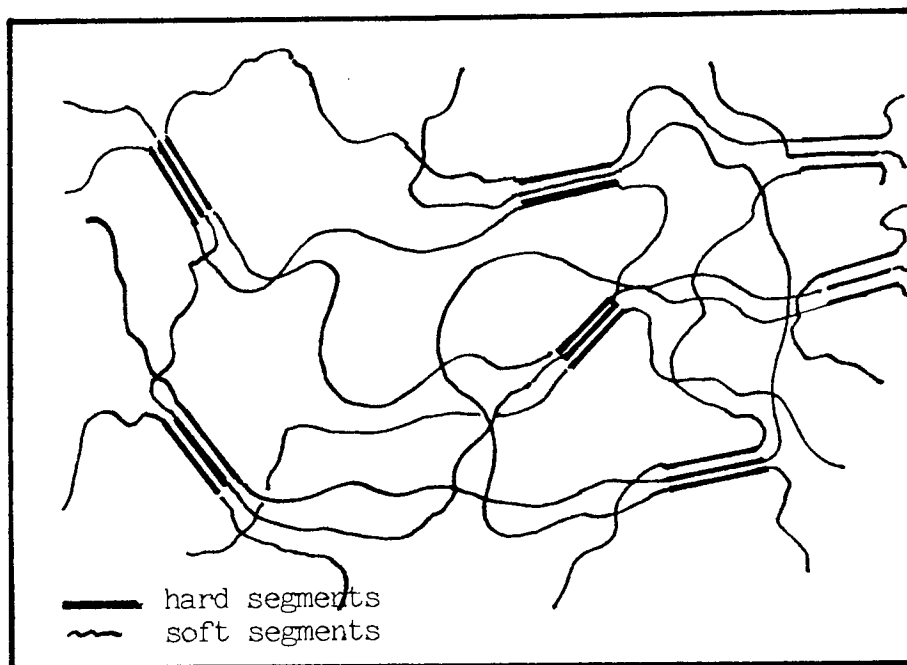

Figure 1.1 Schematic representation of polyurethane thermoplastic elastomer morphology<sup>(30)</sup>

Characteristic properties of polyurethane thermoplastic rubbers are dependent on several factors<sup>(28,32)</sup>, such as: ratio of hard to soft segments; ratio of diisocyanate to total hydroxyl groups; types of polyol and its ratio. The ratio of hard (glycol) to soft (polyol) segments controls both hardness and modulus. The ratio of diisocyanate to total hydroxyl groups determines the degree of cross-linking which affects set properties and oil and heat resistance. The variation of types of polyol and its ratio determine the physical, mechanical and ageing properties. Polyether-based polyurethane thermoplastic rubbers generally exhibit better low temperature and

hydrolytic stability and higher resilience, while polyester-based polyurethane thermoplastic rubbers exhibit better abrasion, toughness and oil resistance. Therefore, for applications which require better hydrolytic stability and low temperature flexibility, the polyether polyurethane thermoplastic rubbers are recommended. Caprolactam polyurethanes on the other hand, offer a good compromise between the polyether and polyester types. In general, therefore, thermoplastic polyurethanes have good abrasion and hydrocarbon solvent resistance, and oxidative stability which make them useful in a variety of applications, ranging from coating, automotive parts, adhesive, wire and cable to footwear. The limitations of polyurethanes are poor resistance to strong acid and alkaline solutions and oxygenated solvents such as ketones<sup>(41)</sup>. Mechanical properties of some commercially important polyurethane thermoplastic rubbers are shown in Table 1.1.

The second major thermoplastic rubber developed is based on linear styrene-diene block copolymer (where the diene is butadiene or isoprene). The first thermoplastic of this category was commercialised by Shell<sup>(31)</sup>. These thermoplastic rubbers (trade name, Kraton) have the polybutadiene, or polyisoprene, as the centre block with the polystyrene as the two end blocks. Polystyrene and polydiene are inherently incompatible which give rise to a tendency to form separate phases and exhibit two glass transition temperatures (Tg's)<sup>(42,43)</sup>. The polystyrene end blocks

agglomerate into domains which are dispersed in a continuous polybutadiene phase<sup>(44,45)</sup> (Fig. 1.2A). These domains are the terminal points for several hundred elastomeric chains and serve as both crosslinkings<sup>(16)</sup> and as reinforcing filler particles<sup>(14,46)</sup>. The high glass transition temperature of the polystyrene ensures that the elastomeric polybutadiene centre block is effectively crosslinked until the temperature is raised substantially high enough to cause the polystyrene domains to soften and dissociate, and thus the polymer is capable of flow during processing.

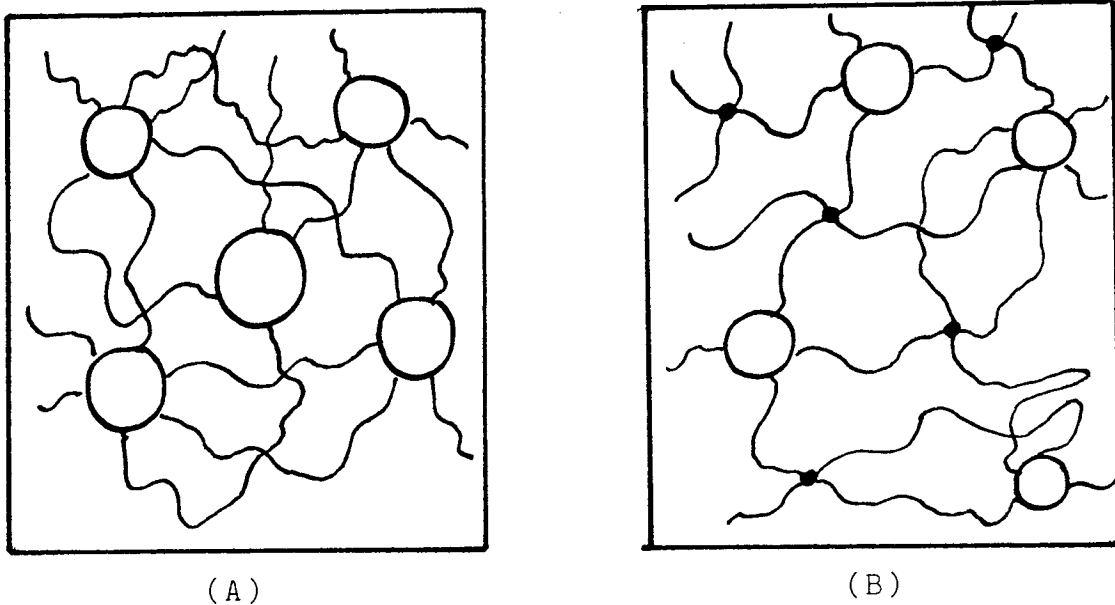

Figure 1.2 Representation of block copolymer morphology<sup>(32,45)</sup>

(A) linear type and (B) radial type

○ - polystyrene domains (T<sub>g</sub> is 90°C)

~ - polybutadiene or polyisoprene phase (T<sub>g</sub> is -60/-70°C)

• - central point of polybutadiene

Another type of polystyrene-polybutadiene-polystyrene (SBS) block copolymer was introduced by the Phillips Petroleum Company in 1973 and was marketed under the trade name of Solprene. This material differed from the linear types by possessing a structure which is described as radial<sup>(47,48)</sup>. This radial structure was produced by having several polybutadiene chains emanating from a central point. The outer end of each of these chains was attached to a polystyrene end block (Fig. 1.2B). More resistant styrenic block copolymers to oxidation and photodegradation are known as Kraton G and Elaxar. These are styrene-ethylene-butylene-styrene<sup>(49)</sup> copolymers.

Styrenic block copolymers are synthesised via homogeneous anionic polymerisation initiated by organolithium compounds (reactions are summarised in Scheme 1.2)<sup>(50,51)</sup>.

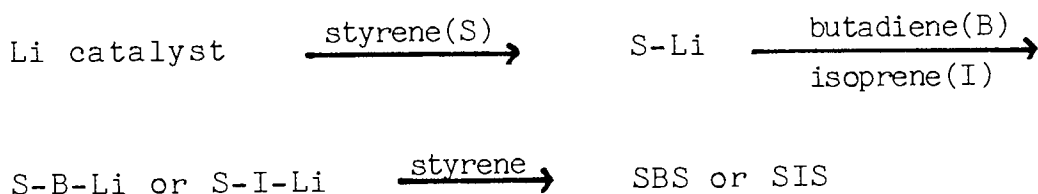

Scheme 1.2 Preparation of styrenic block copolymer thermoplastic rubbers

This system offers precise control over total molecular weight and composition. Properties of styrenic block copolymers are governed by the composition, types of central block and chemical structure. Hardness and tensile

Trade-names & Producers	Type	Hardness	Specific Gravity	Tensile Strength (psi)	Tensile Modulus 100%	300%	Elongation (%)	Notes
Roylar (Uniroyal)								
E-80	Ether	80A	1.10	3500	650	1600	600	Excellent low temp
R-84	Ester	84A	1.18	5000	1000	1500	550	
863	Ether	85A	1.12	4000	1000	2100	550	Excellent extrusion
Estane (B F Goodrich)								
58121	Ester	75A	1.21	3000	600	1400	450	
58300	Ether	80A	1.13	3000	1200	1000	730	
58360	Ester	97A	1.28	4800	1200	2100	500	Flame retardant added
Texin (Mobay Chem)								
480A	Ester	86A	1.20	4500	700	1600	600	
986A	Ether	87A	1.11	4500	850	1400	600	
591A	Ester	91A	1.22	6500	1250	3000	540	Hydrolytic stability
Pelethane (Upjohn)								
2101-80A	Ester	83A	1.18	5400	800	1800	550	
2103-80A	Ether	83A	1.13	4500	800	1675	600	
Elastollan (Elastogran UK)								
C78A	Ester	82A	1.18	35*	3.5*	7.5*	600	
C95D	Ester	98A	1.24	45*	17	30	450	
Cyanaprene (A M Cyanamid)								
5138	Ester	75A	1.24	4-6000	500	1500	700	
9380	Ester	73D	1.24	4-6000	3900	7600	320	

\* MNm<sup>-2</sup> Table 1.1 Physical Properties of Some Commercial Polyurethane Thermoplastic Rubber

strength, for example, can be varied by regulating the styrene content<sup>(52)</sup>. The melt viscosity and oxidative resistance are dependent on the type of centre block. Polyisoprene centre block produces a softer material than that of polybutadiene<sup>(53,54)</sup>. Saturated centre block as in SEBS block copolymer is more resistant to oxidation and photodegradation, therefore is used for applications which require long term and high temperature stability. Generally, styrenic block copolymers exhibit a loss in tensile strength and hardness as temperature increases. Unlike thermoplastics, these materials exhibit low permanent set after extension and are highly flexible. Commercial names and physical properties of some styrenic block copolymer thermoplastic rubbers are summarised in Table 1.2.

The third major thermoplastic rubbers are copolymers based on copolyether-esters, which were first developed by Du Pont in 1972 and were marketed under the trade name of Hytrel<sup>(56-58)</sup>. These materials are condensation products of aromatic dicarboxylic acid, low molecular weight polytetramethylene ether glycol (PTMEG), or its copolymer, and monomeric diols. They are prepared by melt transesterification procedures using starting materials like dimethyl esters of terephthalic acid, glycol of 1000 molecular weight and various monomeric glycol (especially 1,4-butanediol, ethylene glycol<sup>(59-61)</sup> and 1,4-cyclohexanedimethanol<sup>(62)</sup>). A typical reaction in the preparation of thermoplastic rubbers is shown in Scheme 1.3<sup>(57,63,64)</sup>.

Trade-names & Supplier	Specific Gravity	MFI*	300% modulus (psi)	V.T.S. (psi)	Elongation (%)	Hardness (Shore A)	Chemical Structure	
							Molecular Structure	Diene/styrene ratio
Solprene (Phillips Petroleum Co)	0.95	0	600	3900	700	93	Radial	60/40
406	0.94	0	300	2800	700	78	Radial	70/30
411	0.92	3	140	2400	1050	34	Radial	85/15***
418	0.91	0.3**	730	4300	540	85	Radial	70/30
512	0.94	5	300	2700	1000	67	Radial	60/40
475								
Kraton (Shell Chemical Co)	0.94	<1	400	4600	880	71	Linear	70/30
1101	0.91	0	550	3700	560	72	Linear	70/30
G1650	0.94	26	300	1700	1150	46	Linear	67/33
4113								
Europrene Sol T (Eoxy S.p.A)	0.94	-	2.5	15	700	-	Radial	70/30
161	0.94	6****	2.5	13	750	-	Radial	70/30
163	0.96	6****	1.5	15	950	65	Radial	60/40
171	0.96	6****	1.5	13	1000	50	Radial	70/30
172	0.96	6****	1.5	14	950	60	Radial	65/35
174	0.96	6****	1.5	15	700	-	Radial	70/30
AG	0.94	-	2.5	15				

\* - 200°C/5kg  
\*\* - ASTM D 1238, 190°C/2.16 kg  
\*\*\* - Isoprene/styrene, others are butadiene/styrene  
\*\*\*\* - 190°C/5kg

Table 1.2 Trade Names and Physical Properties of Some Thermoplastic Rubbers Based On Styrene Block Copolymers (52,55)



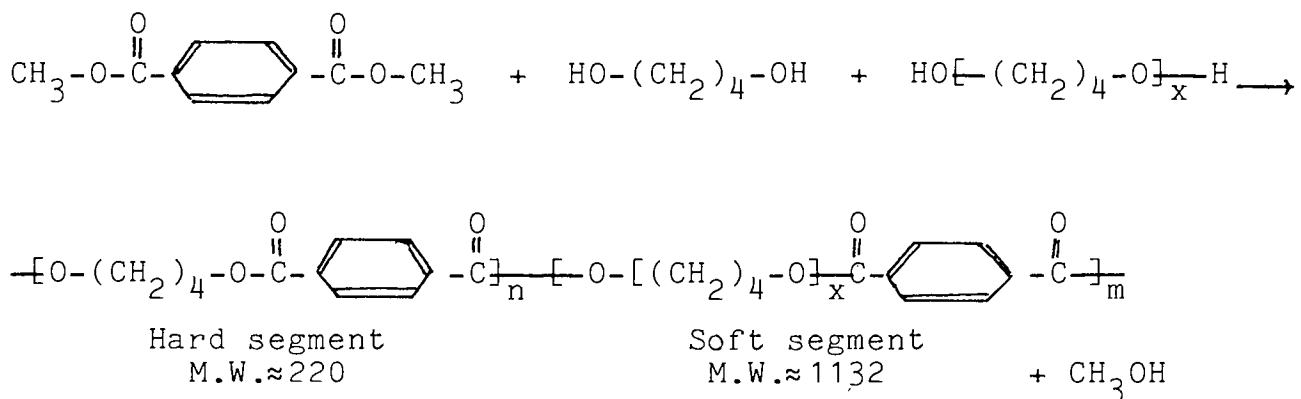

Scheme 1.3 Reactions in the preparation of thermoplastic rubbers based on copolyether esters

The hard segments (tetramethylene terephthalate) are crystallisable and form crystalline domains which are bound to soft amorphous polyalkylene ether glycol terephthalate into a network resembling that of a conventional cross-linked rubber. Transmission electron micrographs have shown that these thermoplastic rubbers exhibit a two phase structure, consisting of a continuous and interpenetrating crystalline phase and an amorphous phase<sup>(56)</sup> (Fig. 1.3).

The crystalline phase serves as a thermally reversible chemical crosslink, and the amorphous phase contributes to the elastomeric character of the polymer. When stress is applied, it is transmitted initially through the crystalline phase by the tie molecules. As the crystallites become oriented, the stress is gradually transferred to the amorphous phase. The amorphous phase, on the other hand, supports all the stress and the polymer then behaves like a typical crosslinked rubber. The physical properties of these polymers are determined by the composition of both

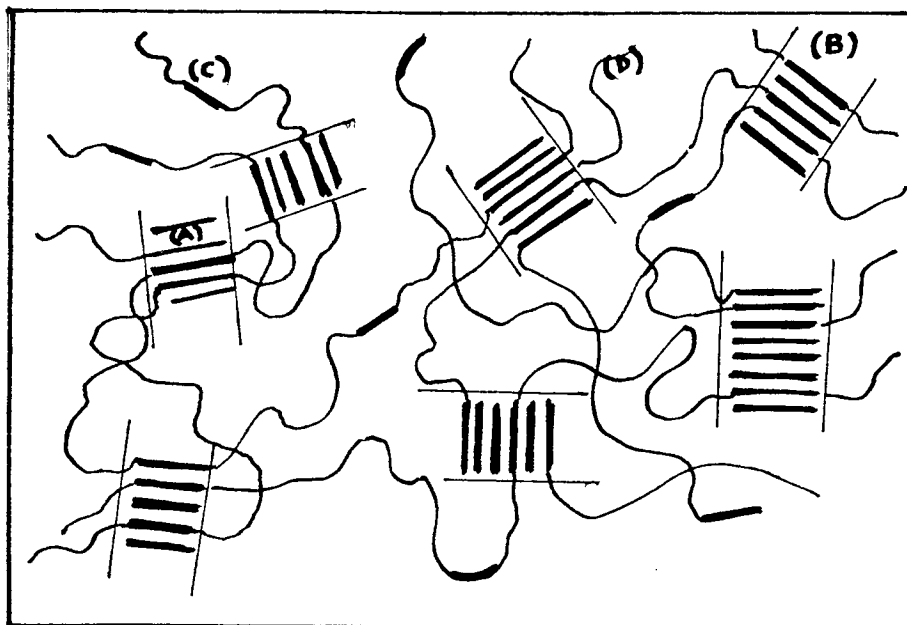

Figure 1.3 Schematic diagram of morphological structure of thermoplastic rubbers based on copoly-ether ester<sup>(56)</sup>

A = crystalline domains

B = area of crystallites

C = non-crystalline hard segment

D = soft segments

segments, the nature and state of crystallisation of the hard segment and the nature of soft segment. Low temperature flexibility decreases with increasing concentration of the hard segments, but tensile and tear strength on the other hand, increase<sup>(63,65)</sup>. The hard segment block length determines the spherulitic size and structure, therefore, it affects the tensile strength and flexibility<sup>(66)</sup>. Like the other types of thermoplastic rubbers, these materials exhibit a decrease in tensile strength and flexural modulus at elevated temperatures.

Hytrel developed by Du Pont are fully polymerised and require no post-curing or annealing to attain their full strength. There are several commercial grades of Hytrel, ranging in hardness from the softest at 40 shore D to the hardest at 72 shore D<sup>(65)</sup> (Table 1.3). These materials offer excellent processing properties and have versatile processability<sup>(58)</sup>, because of their combination of good melt flow properties, melt stability, low mould shrinkage and rapid crystallisation rate. They can be formed into high performance products using the low cost, short cycle methods used for thermoplastic processing, e.g., extrusion, injection and blow moulding.

Current producers of copolyether ester thermoplastic rubbers besides Du Pont, are Akzo Chemie (Holland) and Toyobo (Japan) whose products have the trade mark of Arnitel and Pelprene respectively<sup>(65)</sup>. More recently, polyamide thermoplastic rubbers have been produced by Emser Werke and Huls, using 1,10-decane dicarboxylic acid and laurin lactam to produce the hard segments (in conjunction with the same polyether as used with Hytrel). These are sold under the trade name of Ely 1256, XR3808 and X4006 respectively<sup>(55)</sup>.

The fourth major thermoplastic rubbers represent a distinctively new type of thermoplastic rubber, which differ from the earlier ones which are based on block polymer systems<sup>(67)</sup>. These are known as polyolefin thermoplastic rubbers, and most of the commercially available ones are based on

Properties	Hytrel Polyester Elastomer Hardness (Durometer) Grades				
	40D	47D	55D	63D	72D
Tensile Strength (MPa)	25.5	21.0	37.9	39.3	39.3
Ultimate Elongation (%)	450	500	450	350	350
Flexural Modulus (MPa)	65	109	207	345	585
Specific Gravity	1.17	1.20	1.20	1.22	1.25
Notch Impact, 120D at 24°C (Jcm <sup>-1</sup> )	No break	No break	No break	No break	2.1
at -40°C (Jcm <sup>-1</sup> )	10.6	-	10.6	0.3	0.4

Table 1.3 Mechanical Properties of Hytrel (65)

ethylene-propylene chemistry and/or are extensions of ethylene-propylene rubber technology. The characteristics of this type of material are dependent on both the thermoplastic and elastomeric polymers used as well as the manner in which they are combined.

The first polyolefin thermoplastic rubber was developed by Uniroyal in 1972<sup>(68)</sup> and was produced by mechanical blending polypropylene (PP) and ethylene-propylene rubber (EPDM). The first patents claimed that the EPDM is lightly crosslinked to obtain optimum properties in the blend with PP<sup>(69-70)</sup>. Subsequent entries by Du Pont, Exxon, B.F. Goodrich, Hercules and Ren Plastic have used blends of PP, PE or PP copolymer and EPDM or EPR with no crosslinking<sup>(18,71)</sup>. The developments of thermoplastic rubbers based on butyl rubber grafted polyethylene were reported by Allied Chemical Company as early as 1970, but they have only recently been commercialised as ET Polymers<sup>(67,72)</sup> and have now been withdrawn<sup>(73)</sup>. These materials are prepared by a grafting reaction that chemically combines butyl rubber with polyethylene which differs from the above polyolefin thermoplastic rubbers which are only mechanically blended.

The preparation of polyolefin thermoplastic rubbers is based on carrying out both the blending and crosslinking reactions in one stage by incorporating all components in an external mixer. This procedure is called "dynamic cure blending"<sup>(74)</sup>. A certain degree of crosslinking between

EPDM molecules themselves prevents or reduces the creep, because unlike the other thermoplastic rubbers, in this polymer blend the weak intermolecular binding forces are the main factor responsible for their strength. In fact, the only linking forces acting between EPDM and polyolefin molecules are the very weak van der Waal's forces and pseudo-crosslinking effects shown by microcrystalline domains of polyolefin, e.g., polypropylene, and by the block copolymer sequences aligned along the largely amorphous chains of EPDM. Therefore, the properties of these blends are dependent upon the component formulations, type of polyolefin, degree of crosslinking and mixing operation<sup>(74-76)</sup>. Tensile strength and stress level vary directly with the hardness of the material, this latter property is determined by the polypropylene content. Hardness, tensile strength and stress at given percent strain decrease with the increase in temperature.

The polyolefin thermoplastic rubbers have both oxidative stability and low temperature flexibility, so they are well suited for automotive, wire and cable, and general moulded articles<sup>(67)</sup>. Most of the general purpose grades are compatible with one another and can be blended in all proportions. These can also be modified by blending with a number of other polyolefin polymers and by addition of fibre glass<sup>(77)</sup>. The commercial polyolefin thermoplastic rubbers available are summarised in Table 1.4.

Supplier	Trade names	Hardness (Shore A)	T.S. (MPa)	E.B. (%)	Specific Gravity
Uniroyal	TPR 1600	67	4.5	230	0.88
	TPR 1700	77	6.6	200	0.88
	TPR 1800	88	9.7	210	0.88
	TPR 1900	92	12.8	230	0.88
	TPR 2800	87	9.0	150	0.88
	TPR Series 3000	80	11.8	360	0.88
	TPR Series 400	78-90	6.6-12.4	300-400	0.88
	TPR Series 500	60-91	3.1-13.8	400-790	0.88
Du Pont	Somel 301G	40	11.4	230	1.02
	401T	50	21.8	390	1.02
	402T	50	30.0	595	0.89
B F Goodrich	Teclar 100	93	12.4	290	0.89
	Teclar 301	83	6.2-7.9	750-850	0.84
	Teclar 400	90	17.8	870	0.91
	Teclar 402	78	8.6-10.4	900	0.93
	Teclar 405	54	4.5	no break at 1000	0.88
Hercules	Profax SB 814	96	11.0	500	0.89

Table 1.4 Commercial Polyolefin Thermoplastic Rubbers  
(after Reference 67)

The main attractions of thermoplastic rubbers which are based on polyolefin blends are:

- (i) Mechanical blending, which is used in the preparation of polyolefin thermoplastic rubbers, is a less expensive and a simpler method compared to the copolymerisation processes. However, it does not always provide a satisfactory alternative to copolymerisation, but polymer blends have been successfully used in an increasing number of applications in recent years<sup>(78)</sup>.
- (ii) Polymers used to produce the blends, are, in most cases, produced on a large scale and are relatively inexpensive<sup>(75)</sup>.
- (iii) The desired properties can easily be adjusted by varying the composition and the type of polymer components<sup>(79)</sup>.

A new entry in the polyolefin thermoplastic rubber family is thermoplastic natural rubber (TPNR). This new material is based on mechanical blending of natural rubber and a thermoplastic polyolefin, namely polyethylene and polypropylene<sup>(3)</sup>. Malaysian Rubber Producers and Research Association (MRPRA) developed this new thermoplastic rubber by adopting the method used in the preparation of Uniroyal TPR materials<sup>(5)</sup>.



### 1.3 Developments in Thermoplastic Natural Rubber (TPNR)

It was shown in Section 1.1 that the concept of thermoplasticity in elastomers lies in the structure of the components of the polymer blends or block copolymers. Thermoplastic rubbers are made of two phases, a glassy or crystalline phase and a rubbery phase. The crystalline phase acts as heat fugitive crosslinks between the amorphous rubbery phase. This concept is also adopted in the preparation of thermoplastic natural rubbers (TPNR). Here there are three different approaches that can be used to achieve those useful properties:

- (i) Graft copolymerisation of natural rubber with hard thermoplastic.
- (ii) Mechanical blending of natural rubber and polyolefins.
- (iii) Vulcanisation of natural rubber with thermolabile crosslinks.

#### 1.3.1 Graft Copolymerisation of Natural Rubber with Hard Thermoplastic

Composite materials with chemically bonded natural rubber to a second, hard polymer are not new, and have been studied extensively, especially at the Natural Rubber Producers and Research Association (NRPRA)<sup>(80)</sup>. This

work has resulted in the commercial production of a composite material of natural rubber and polymethylmethacrylate (PMMA) known as "Heveaplus MG". This material, however, is not a thermoplastic rubber in the present day commercial meaning of the term. As prepared, Heveaplus MG is a tough material which softens on heating but cannot be directly processed by the normal thermoplastic processing techniques e.g., injection moulding, because of its very high viscosity and gel content. Conventional mastication will confer a degree of processability but the product of the mastication does not have high strength or toughness unless it is subsequently vulcanised. High strength and toughness cannot be obtained in conjunction with direct mouldability<sup>(81)</sup>. Numerous modifications to the Heveaplus process have failed to produce major changes in the properties of the materials. Failure to produce a viable thermoplastic rubber via a modified Heveaplus process may be due to the chemical nature of the hard polymer and the fundamental molecular architecture<sup>(81)</sup>. The proportion of backbone chains containing the hard polymer segments and which contain no grafts is very small, natural rubber chains in Heveaplus have small number of long hard polymer chains attached to them and therefore the rubber thermoplasticity properties cannot be achieved.

Mechano-chemical reactions and graft copolymerisation are two common synthetic routes for producing hard polymer grafts on natural rubber. Mechano-chemical synthesis utilises the

principle of physical scission of carbon-carbon bond linking the atoms of macromolecular rubber chains under the influence of an applied stress at low temperature. It is known<sup>(82)</sup> that polymeric radicals are formed during cold mastication of natural rubber. This is described below (Scheme 1.4):

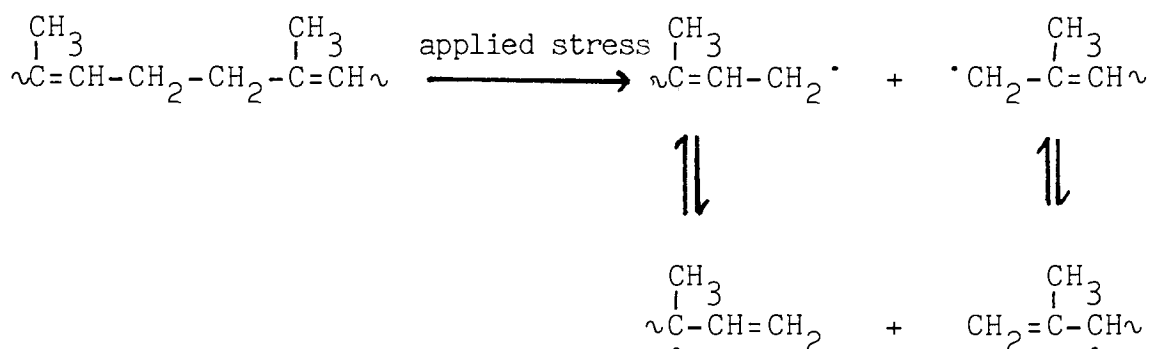

Scheme 1.4 Mechano-chemical reactions in natural rubber

In the presence of another polymer e.g., polydiene which may undergo similar reactions to produce another polymeric radical, a complex branched block or graft copolymer may be formed by one of the following reactions<sup>(83,84,85)</sup> (Scheme 1.5):

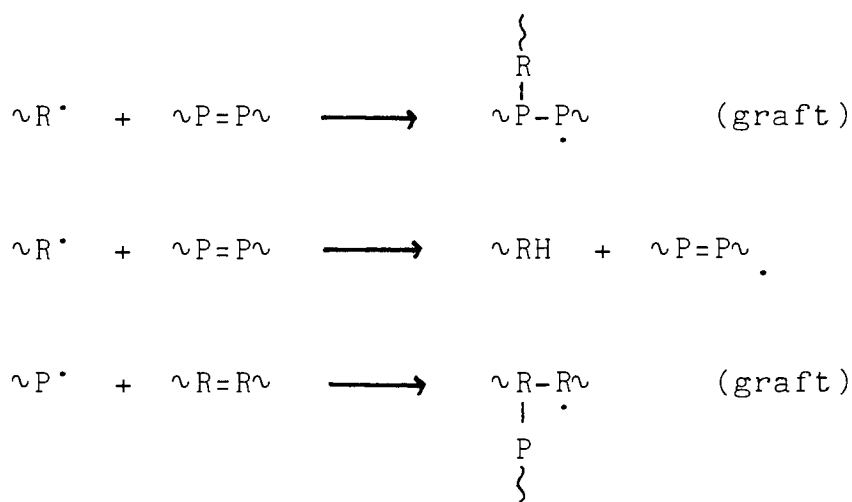

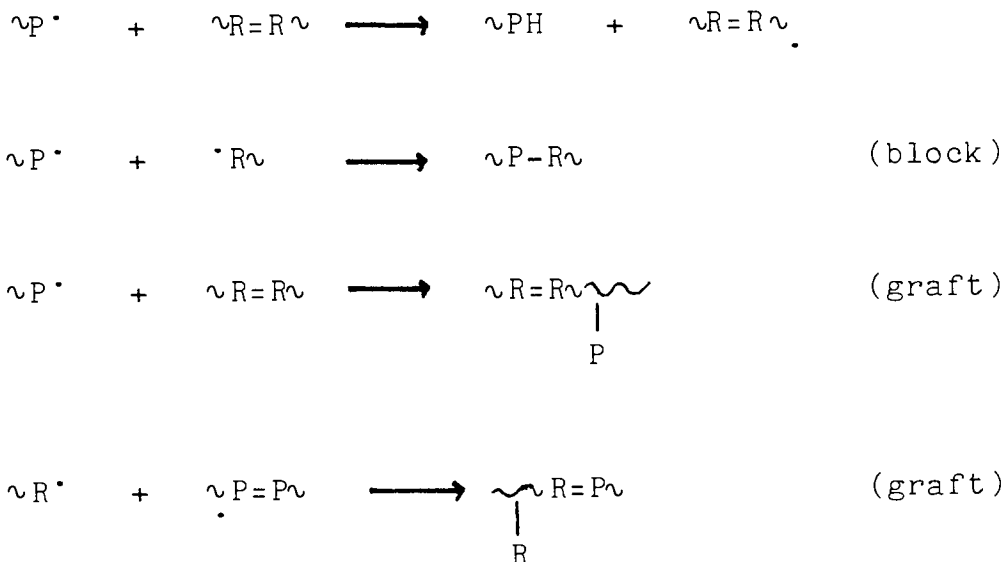

Scheme 1.5 Possible grafting and block copolymerisation during mechano-chemical reaction of rubbers  
 ( $\sim R^{\cdot}$  macroradical of natural rubber  
 $\sim P^{\cdot}$  macroradical of polydiene rubber)

The results of these reactions have been demonstrated<sup>(86,87)</sup> in the cold comastication of natural rubber and polydiene rubbers under conditions of intensive shear and relative absence of oxygen which lead to the formation of block and graft copolymers. Synthesis of graft copolymer natural rubber has also been carried out in cold mastication of natural rubber with vinyl monomers<sup>(88-90)</sup>. However, the products were shown to be a mixture of graft and block copolymers since the reactions involved are complex as shown below<sup>(85)</sup> (Scheme 1.6):

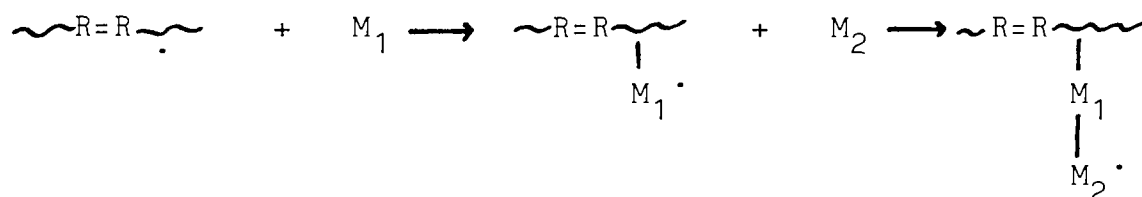
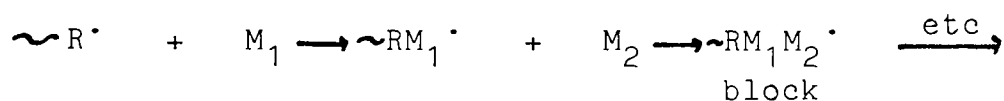
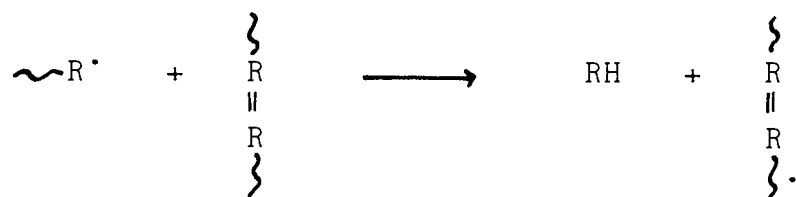

Scheme 1.6 Copolymerisation of vinyl monomer onto natural rubber

( $\sim R=R$  natural rubber;  $\sim R^\cdot$  macroradical of natural rubber; M vinyl monomer)

In this method, the macroradicals ( $\sim R^\cdot$ ) have the function analogous to the function of free radical produced by thermal scission of catalyst molecules, and therefore, these macroradicals have the ability to propagate the subsequent reactions taking place, in this case common free radical polymerisation. The molecular structure of the materials obtained by mechanochemical reactions suggests<sup>(81)</sup> that rubber thermoplasticity is unlikely to be achieved.

Graft copolymerisation is the second synthetic approach in grafting hard polymers into natural rubber backbone. Grafts of a variety of polymers into natural rubber in the solid, solution and latex phases were prepared<sup>(91-99)</sup>. The grafting

mechanism was elucidated by the use of  $^{14}\text{C}$  labelled initiator<sup>(98)</sup> and the transfer reaction shown follows the reactions below (Scheme 1.7):

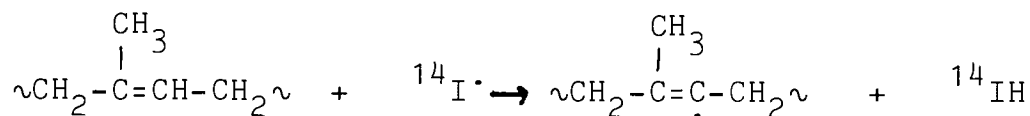

to a lesser extent

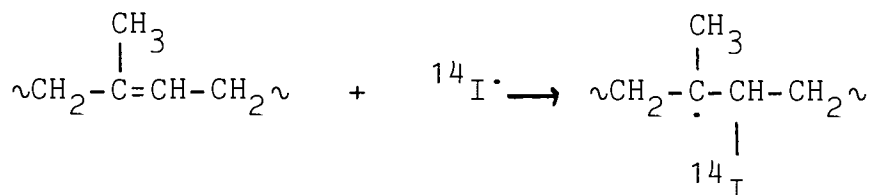

Scheme 1.7 Transfer reaction of free radical in natural rubber ( $^{14}\text{I}\cdot$  free radical produced in the thermal scission of  $^{14}\text{C}$  labelled initiator)

Many commercial processes which are available for grafting monomers into natural rubber are based on redox polymerisation<sup>(99)</sup>. Natural rubber latex is peroxidised by atmospheric oxygen and this leads to the formation of peroxy radicals which are the main initiators<sup>(100,101)</sup> (Scheme 1.8).

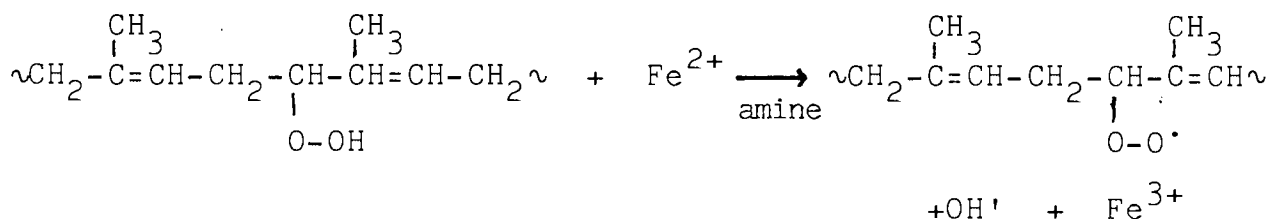

Scheme 1.8 Formation of natural rubber peroxy radical

A new method of grafting styrene into natural rubber backbone by "ene" addition<sup>(102,103)</sup> seems to be promising in preparation of thermoplastic natural rubber graft<sup>(104)</sup>. The graft polystyrene is called prepolymer which is azodicarboxylate functional polystyrene (Scheme 1.9). Synthesis of this polystyrene is carried out by anionic polymerisation using butyl lithium and ethylene oxide.

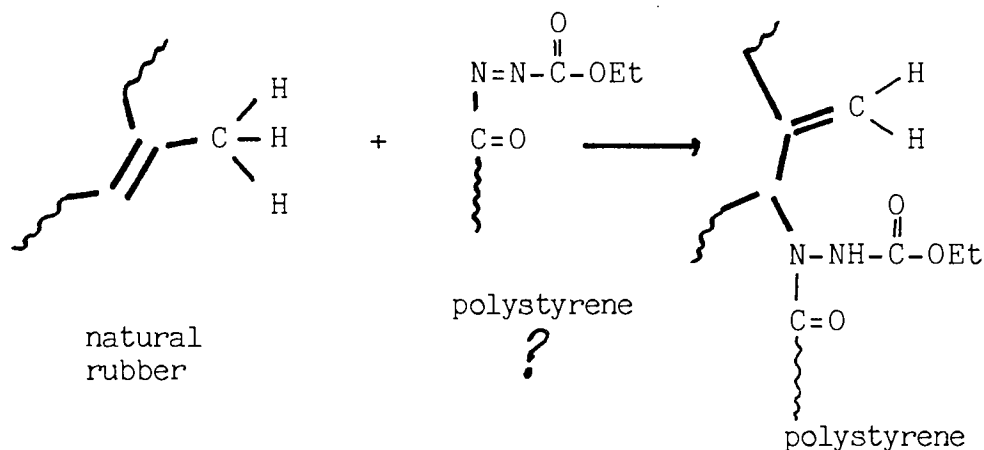

Scheme 1.9 "Ene" addition of azodicarboxylate functional polystyrene into natural rubber backbone

This method offers considerable control over the composition and structure of the graft copolymer and which is applicable to natural rubber and to synthetic polyisoprene. The products resemble styrene-diene thermoplastic block copolymer in their general properties but are structurally different. The properties are determined by the optimum molecular weight of the polystyrene and the grafting efficiency<sup>(81)</sup>.

### 1.3.2 Mechanical Blending of Natural Rubber and Polyolefins

It was mentioned in Section 1.3 that the preparation of mechanically blended natural rubber-polyolefin thermoplastic adopts the method used in the preparation of Uniroyal thermoplastic rubber materials<sup>(5)</sup>. An organic peroxide or other crosslinking agent for the rubber phase may be added during mixing to achieve "dynamic cure" which improves some physical properties such as hardness, strength and elastic properties, and thermoplastic behaviour is retained because the crosslinked rubber is dispersed as very small particles<sup>(106)</sup>. Thermoplastic natural rubber blends can be prepared in any internal mixer robust enough to withstand the high forces required to break down raw rubber. Control of temperature of the batch during mixing is very important, it must be higher than the melting point of the polyolefin (135°C for HDPE; 165°C for PP), but it should not be allowed to exceed 200°C because degradation of NR may occur. The processing cycle is quite fast as shown in a typical cycle for partially crosslinked thermoplastic natural rubber<sup>(106)</sup>:

0 mins	:	NR; PP and filler (if used) are added
2-3 mins	:	peroxide crosslinking agent is added
5 mins	:	antioxidant is added
6 mins	:	dump



The general physical properties are dependent on the ratio of natural rubber to polyolefin, and hence properties can be adjusted for any given purpose (Table 1.5). The incorporation of filler, such as black, is limited to small amount since it does not improve the physical properties and the blends become heavier and denser. The addition of mineral oil to thermoplastic natural rubber blends reduces the melt viscosity which can be beneficial in processing. High viscosity oil is recommended in order to avoid surface bloom problems.

It has been found<sup>(105)</sup> that thermoplastic natural rubber, unlike vulcanised rubber, is remarkably resistant to heat ageing. The weathering resistance may be increased by using synergetic stabiliser systems, such as dilauryl dithiopropionate and a U.V. absorber. Moreover, the use of dicumyl peroxide as crosslinking agent must be restricted. Table 1.6 compares properties of the different thermoplastic rubbers discussed above.

### 1.3.3 Vulcanisation of Natural Rubber with Thermolabile Crosslinks

Attempts were made<sup>(107)</sup> to investigate the possibility of conferring thermoplastic on highly elastic system by introducing specific chemical crosslinks which are capable of undergoing rapid exchange at high temperature. Typical chemical crosslinks were achieved through chemical modification

Blend Materials	Colour							
	1 White	2 White	3 Black	4 Natural	5 Black	6 Natural	7 Black	8 Black
	Parts by weight							
Natural rubber	70	50	50	55	42	35	30	15
Propathene GWM 101 <sup>a</sup>	30	50	50	-	-	-	-	-
RMT 6100 <sup>b</sup>	-	-	-	45	60	-	-	-
KMT 6100 <sup>b</sup>	-	-	-	-	-	65	70	-
Propathene GWM 22 <sup>c</sup>	-	-	-	-	-	-	-	8
Oil (Sunpar 2280)	15	-	-	-	8	-	-	-
Silica (Ultrasil VN3)	15	-	-	-	-	-	-	-
Titanium Dioxide	1	1	-	-	-	-	-	-
Talc	-	85	-	-	-	-	-	-
Zinc Oxide	4	-	-	-	-	-	-	-
Stearic acid	1	-	-	-	-	-	-	-
Paraffin wax	-	3	-	-	-	-	-	-
EEF Black	-	-	-	-	8	-	-	-
HAF Black	-	-	1	-	-	-	10	1
Phenolic anti-oxidant	-	0.3	-	0.5	-	0.3	-	-
Permanax CNS	0.5	-	-	-	-	-	-	-
Floctol H	-	-	0.2	-	0.5	-	0.5	0.5
Irgonox PS 800	-	-	-	0.2	0.2	0.2	0.2	0.2
Tinuvin 327	-	-	-	0.2	0.2	0.2	0.2	0.2

Table 1.5 Typical TPNR Blends and Their Properties

Continued.....

Physical Properties	Colour							
	1 White	2 White	3 Black	4 Natural	5 Black	6 Natural	7 Black	8 Black
Density Mg/m <sup>3</sup>	1.02	1.28	0.91	0.91	0.94	0.91	0.95	0.91
Shore A hardness	80	95	96	96	97	98	99	100
Shore D hardness	34	46	47	46	50	60	65	68
Flexural Modulus (MPa)	-	200	300	290	260	600	700	800
Tensile Strength (MPa)	8	11	12	11	11	16	18	-
Tensile Yield Stress (MPa)	-	-	-	-	-	17	18	23
Modulus at 50% Elongation (MPa)	5	9	10	9	10	17	17	-
Elongation at Break (%)	300	300	350	350	325	400	400	-
Tear Strength N/mm	40	75	80	-	92	150	-	-

Table 1.5 Continued

Type	Approximate Hardness, shore	Density ( $\text{gcm}^{-3}$ )	Tensile Strength (MPa)	Elongation at break (%)
TPNR blends	70A-60D	0.91	6-20	200-500
Olefinic TR's	65A-60D	0.89	5-20	200-500
TPNR grafts	40A-95A	0.95	10-25	300-800
SBS and SIS copolymers	40A-95A	0.95	10-25	600-1200
Polyurethane TR's	70A-75D	1.25	20-50	200-700
Copolyester TR's	40D-72D	1.25	25-40	350-450

Table 1.6 Typical Properties of Thermoplastic Rubbers (106)

of natural rubber to give pendant hydroxyl groups (Scheme 1.10) which were then used as crosslinking sites to form  $\beta$ -keto-ester or malonate crosslinks. The modified natural rubber (hydroxylated NR) was crosslinked with dicumyl peroxide, diphenyl acetodicarboxylate (DPA) and diphenyl malonate (DMA), by conventional milling and compression moulding techniques. Scheme 1.11 shows typical crosslinking reactions with diphenyl acetodicarboxylate, and the crosslinks are ester type.

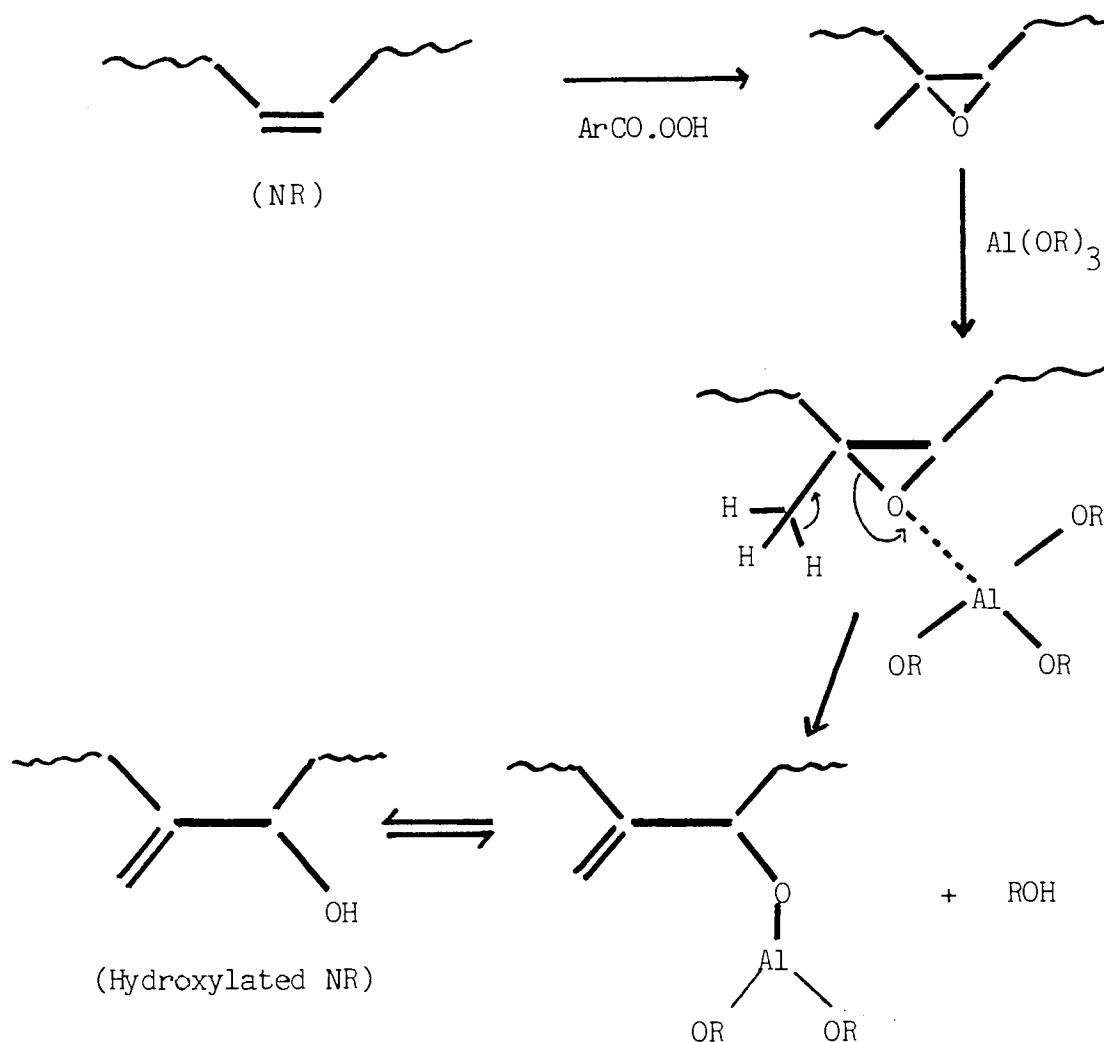

Scheme 1.10 Reactions in the preparation of hydroxylated natural rubber<sup>(107)</sup>

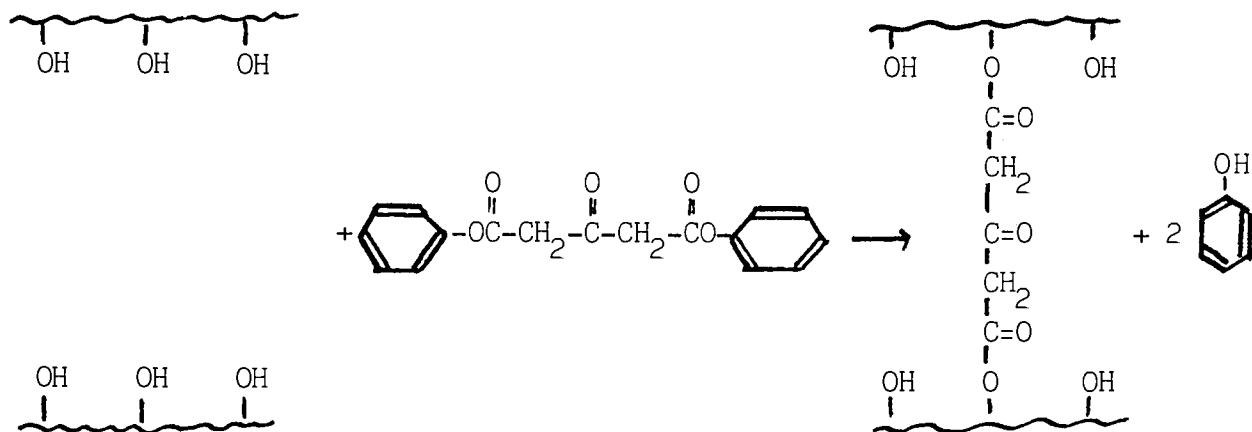

Scheme 1.11 Crosslinking reaction of hydroxylated natural rubber with diphenyl acetodicarboxylate (DPA)<sup>(107)</sup>

The results of this experiment show that natural rubber constructing networks with crosslinking of these esters has exhibited some degree of remouldability but was prevented from achieving complete relaxation of remoulding stresses by the incursion of permanent crosslinks.

CHAPTER TWO

EXPERIMENTAL

## 2.1 Materials

The polymers used were: natural rubber, SMR 5 grade and whole tyre reclaim, supplied by MRPRA and United Reclaimed Liverpool, respectively. Two grades of polypropylene were used; stabilised Propathene HWM 25 (granules) and unstabilised polymer Propathene HF 22 (powder). Stabilised Low Density polyethylene (Alkathene 30) and unstabilised polymer powder (Alkathene WJG 47) were also used. All polyolefins were supplied by Imperial Chemical Industries Ltd. Ethylene-propylene diene terpolymer (EPDM) was supplied by Exxon Chemicals under the trade name of Vistalon 6505. Chemicals and solvents used are listed in Appendix I.

## 2.2 Processing and Sample Preparations

Preparations of natural rubber-polypropylene blends were carried out on a Brabender Torque Rheometer, which is essentially a small mixing chamber containing two contra-rotating rotors. Ratios of natural rubber to polypropylene used were 70/30; 60/40; 50/50 and 40/60, and the sequence of addition of polymers was investigated. At the end of the processing operation, the hot blends were chilled in water to avoid uncontrollable thermal oxidation.

Natural rubber and polypropylene were also blended in a Banbury mixer at 150<sup>o</sup> and 160<sup>o</sup>C for 10 minutes. Natural rubber and polypropylene were blended first for 3 minutes, and this was followed by the addition of dicumyl peroxide



after which mixing was continued for a further 7 minutes. The hot blends were chilled in water and were subsequently granulated in the Shaw Granulator. Natural rubber-polypropylene blends were also prepared on a Busko Kneader at 150°, 160° and 170°C using a speed of 48 rpm.

Preparations of polypropylene-low density polyethylene blends were carried out in a Brabender Torque Rheometer (closed mixing; at 180°C for 5 minutes)<sup>108-110</sup> and a Busko Kneader (at 165°C, 48 rpm). 5-6 g of the processed polymer blends were compression moulded at 180°C for 3 minutes, between two stainless steel plates using a special cellophane as a mould releasing agent to produce film of approximately  $(1.5-2.0) \times 10^{-2}$  cm thickness<sup>(111)</sup>.

Polymer blend granules were injection moulded on an Edgwick 1214 HY injection moulding machine using the following conditions:

Barrel temperatures:	170°-180° and 200°C
Mould temperature:	60°C
Injection pressure:	47 MPa
Screw speed:	50 rpm
Cooling time:	16 seconds

## 2.3 Testing for Compression Moulded Samples

### 2.3.1 Tensile Properties Measurements

The tensile properties tests were carried out on an Instron Tensile Tester, Model TM.TS. using a cross-head speed of 3 cm per minute<sup>(76)</sup>. Tests were carried out on 6 samples for each run and average results were taken. The nominal dimension of the dumb-bell test piece (type C) was as follows:

Length: 5.00 cm  
Width: 0.827 cm  
Thickness: 0.015-0.020 cm  
Gauge length: 3.00 cm

From the stress-strain curves, tensile modulus, ultimate tensile strength (UTS) and elongation at break (EB) were calculated using the following equations;

$$\text{UTS (MPa)} = \frac{\text{Force at break}}{\text{Thickness} \times \text{width}} \quad (2-1)$$

$$\text{EB(\%)} = \frac{\text{Chart length} \times \text{cross-head speed} \times 100}{\text{Chart speed} \times \text{gauge length}} \quad (2-2)$$

$$\text{Tensile Modulus (MPa)} = \frac{\text{Chart speed} \times \text{gauge length} \times \text{initial slope}}{\text{Cross-head speed} \times \text{thickness} \times \text{width}} \quad (2-3)$$

### 2.3.2 Dynamic Mechanical Properties Measurements

A direct reading dynamic viscoelasticometer Rheovibron Model DD VII (Toyo Measuring Instrument Company Ltd, TMI. Tokyo) was used for measurement of the temperature or frequency dependence of dynamic mechanical properties of polymers in both the amorphous and the crystalline state<sup>(112)</sup>.

Samples were prepared by stamping out from the compression moulded films which have dimensions of length between 0.5-0.6 cm, maximum breadth 0.5 cm and thickness 0.15-0.20 mm. Each sample was set horizontally in the furnace with both its ends attached to two gauges (T-1 stress and T-7 strain) with the help of a chuck and connecting rod. One of the two gauges is a transducer of displacement (T-7) and has a maximum force and displacement of 8g - 0.3 mm and an output of  $4000 \times 10^{-6}$  strain. The other is a transducer of generated force (T-1 stress). It has a maximum force of 550 g and an output of approximately  $4000 \times 10^{-6}$  strain. Both the amplitude of displacement and the main magnitude of load applied on the specimen were measured by T-7 and T-1 gauges respectively and when they were adjusted to unity, their phase angle,  $\tan \delta$ , can be read off directly from the main meter. The storage modulus ( $E'$ ) and the loss modulus ( $E''$ ) were calculated from the amplitude of stress and strain and  $\tan \delta$  value. In practice, they are calculated by the following equations<sup>(112)</sup>:

$$\text{Dynamic complex modulus (E*)} = 2.0 \times \frac{1}{A \times D} \times 10^9 \times \frac{L}{S} \quad (2-4)$$

(dynes cm<sup>-2</sup>)

$$\text{Dynamic storage modulus (E')} = |E*| \cos \delta \quad (2-5)$$

(dynes cm<sup>-2</sup>)

$$\text{Dynamic loss modulus (E'')} = |E*| \sin \delta \quad (2-6)$$

(dynes cm<sup>-2</sup>)

where:

L = length of the sample (cm)

S = cross section area (cm<sup>2</sup>)

A = value from Table 2.1 obtained from the value of amplitude factor used when measuring tan δ.

D = dynamic force dial reading.

Amplitude factor (db)	Value of A
0	31.60
10	10.00
20	3.16
30	1.00
40	0.316
50	0.10
60	0.0316

Table 2.1 Value of A with the Value of the Amplitude Factor<sup>(112)</sup>

### 2.3.3 Determination of Binding of Natural Rubber

The determination of the extent of binding of natural rubber on polypropylene was carried out by fractional precipitation method which was based on the fact that polypropylene does not dissolve in cold dekalin (Decahydronaphthalene), while unbound natural rubber does. About 0.5 g of the blend was cut into small pieces and placed into a small erlenmeyer flask. Dekalin was added and the solution was heated at 170°C for about 3 minutes until all of the material dissolved. The flask was then cooled in running water causing precipitation of a mixture of polypropylene and bound rubber, while the unbound natural rubber remained dissolved in dekalin. The precipitate was separated by filtration, and was then redissolved. This was repeated three times and the final precipitate was dried in a vacuum oven until a constant weight. The bound natural rubber was calculated by the following equation:

$$\text{Bound natural rubber (\%)} = \left[ \left( \frac{A - B}{A} \right) \times 100\% \right] - 40\% \quad (2-7)$$

where:

A = weight before extraction

B = weight after extraction

40% = polypropylene fraction in the blend

### 2.3.4 Determination of Gel Content

50 ml of tetrahydrofuran (THF) was added to 0.5 g samples cut into small pieces. This was then left to stand for

24 hours. The gel formed was filtered out, and was dried in a vacuum oven until a constant weight.

$$\text{Gel content (\%)} = \frac{\text{dry weight}}{\text{weight of sample}} \times 100\% \quad (2-8)$$

### 2.3.5 Measurement of Melt Flow Index

Melt Flow Index (MFI) is a measure of the melt viscosity of the polymer which in turn is related to the molecular weight. It is defined as the amount of polymer (in grammes) extruded by a given load through a standard die in a given time (usually 10 minutes). A low melt flow index corresponds to a high melt viscosity and a high molecular weight<sup>(113)</sup>. Thermal oxidation of polymer will affect its molecular weight by virtue of such reactions as chain scission, crosslinking etc., and this will be reflected in the melt flow index value. Hence, the MFI measurement will provide a means of detecting any oxidation which may occur during heat treatment of the polymer.

The apparatus used was a Davenport Melt Flow Indexer having a die of 0.0825 inch in diameter. Extrusion temperature was  $230^{\circ} \pm 0.5^{\circ}\text{C}$ . The barrel was charged with 5.0 g of polymer (tampered down with a charging tool to exclude air), and was left for 4 minutes to allow temperature to equilibrate throughout the sample. A load of 50 Newton (about 5.097 kg)<sup>(114)</sup> was then used to extrude the melt. The

extrudate was cut with a sharp-edged instrument. The time interval for the first extrudate was 60 seconds and was discarded, then 6 successive cut-off's were taken at the end of 30 seconds. Any cut-off that contained air bubbles was rejected and each cut-off was weighed separately and their average weight was determined. The Melt Flow Index was calculated from the following equation:

$$\text{MFI (g/10 mins)} = \frac{\text{Average weight of cut-off (g)}}{\text{Interval time (sec)}} \times 10 \times 60 \quad (2-9)$$

### 2.3.6 Determination of Melt Rheology

This determination was carried out to measure the viscosity of the melt under a range of shear rates at a given temperature. This gives a clearer picture of the melt behaviour of the polymer when compared to the MFI measurement in which only one shear rate value is applied.

The apparatus used in this determination was a Weissenberg Rheogoniometer which is basically a simple cone and plate viscometer<sup>(115)</sup> (Figure 2.1). The flat platen A is stationary and the conical platen B is moving with an angular velocity  $\beta$  which can be regulated by changing the gear box setting. The temperature was set at 230°C (similar to that used in the Melt Flow Index measurement) and the force applied was a rotation force. The sample film was folded and cut into a circular shape (3 cm diameter). This was put between the two platen and was left to allow the

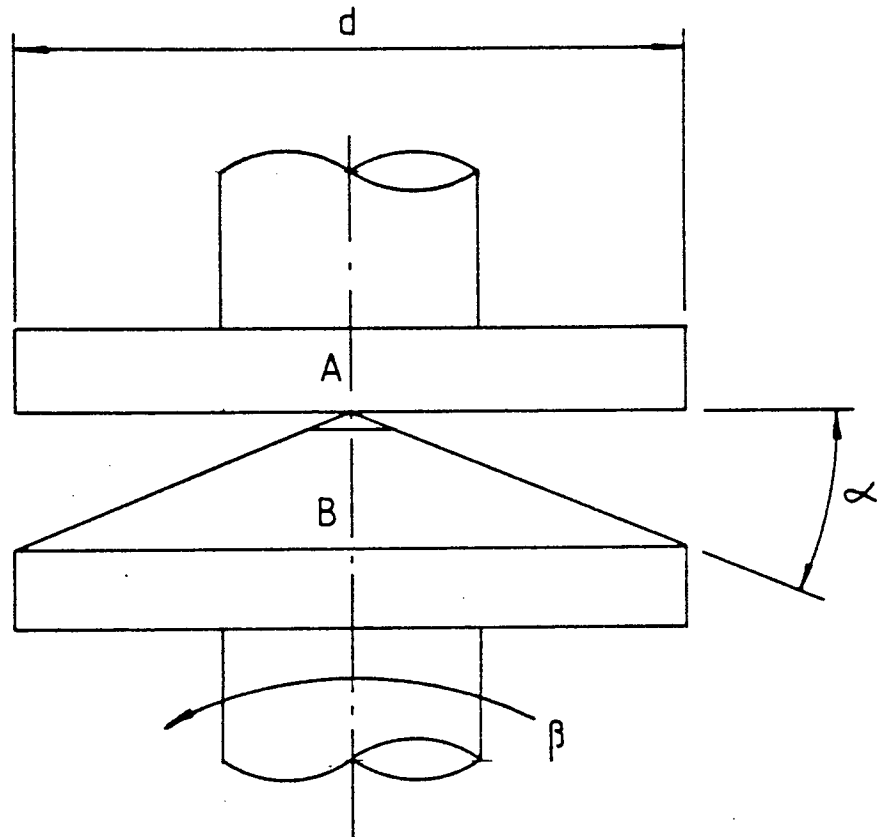

- A = Flat platen
- B = Conical platen
- $\alpha$  = Angle of cone
- $\beta$  = Angular velocity
- $d$  = Diameter of platens

Figure 2:1 Weissenberg Rheogoniometer



temperature to reach 230°C. The excess sample from the edge of platens was removed by means of a brass knife in order to avoid the sample being dragged into the side. The measurements of viscosity were carried out at the gear box setting of 3.0; 2.5; 2.0; 1.5 and 1.0 in order to vary the shear rate since the gear box setting regulates the angular rotation of the conical platen. The torsion head movement was read off from the torsion head gauge. The viscosity of the melt was calculated from the following equations:

$$\text{viscosity } (\eta) = \frac{t \times \alpha \times \Delta T \times K_t}{94.25 \times d^3} \quad \text{poise} \quad (2-10)$$

$$\text{shear rate } (\dot{\gamma}) = \frac{360}{\alpha t} \quad \text{sec}^{-1} \quad (2-11)$$

where: the value of  $t$  is dependent on the angular rotation of the conical platen. This can be seen from the conversion Table 2.2.

$\alpha$  = angle of cone (degrees), which is 4° 8'.

$\Delta T$  = movement of torsion head transducer in thousandth of an inch,

$$= \frac{\text{Torsion head reading}}{100} \times \text{Torsion head range}$$

$K_t$  = torsion head constant (dyne cm/thousandth inch of movement of the transducer), which is  $3.372 \times 10^4$

$d$  = diameter of platens, which is 2.5 cm.

Gear box setting	R.P.M.	t (sec/rev)
0.0	$3.75 \times 10^2$	$1.60 \times 10^{-1}$
0.5	$1.19 \times 10^2$	$5.06 \times 10^{-1}$
1.0	3.75x10	1.60
1.5	1.19x10	5.06
2.0	3.75	1.60x10
2.5	1.19	5.06x10
3.0	$3.75 \times 10^{-1}$	$1.60 \times 10^2$

Table 2.2 Conversion table of gear box setting - t<sup>(115)</sup>

### 2.3.7 Ultra-violet Irradiation

Ultra-violet cabinet was used which comprises of a metal cylinder of about 110 cm in outer diameter and has a concentric rotating sample drum (circumference of 15 cm from the periphery of the metal cylinder). Twenty eight fluorescent tube lamps (20 W each) are mounted in a cylindrical array on the inside of the cylinder to provide radiation source which consists of 21 lamps, type C (Phillips Actinic Blue OS) and 7 lamps, type A<sub>1</sub> (Westinghouse Sunlamps FS 20). These lamps are symmetrically distributed to give a combination of one lamp type A<sub>1</sub> for every three lamps type C. Since the maximum of the relative intensity of lamps of type A<sub>1</sub> is at 317 nm and that of lamps type C is 374 nm, hence the wavelength distribution offered by the above combination is between 280-500 nm. The samples were mounted on a rotating sample drum, and the light beam fell perpendicularly on the surface of the samples. The temperature recorded inside the cabinet with the lamps on was 30<sup>0±</sup> 1<sup>0</sup>C.

### 2.3.8 Infra-red Spectroscopy

Infra-red spectra were recorded on a Perkin Elmer grating infra-red spectrophotometer Model 599. Throughout the experiment, the formation and growth of carbonyl group at 1710 cm<sup>-1</sup> as the product of photo-oxidation have been followed. The peak at 2720 cm<sup>-1</sup> was taken as a reference peak since it remained constant during UV-irradiation. The

growth of carbonyl group was expressed as index which is defined as the ratio of the absorbance of carbonyl group to that of the reference peak.

$$\text{Carbonyl index} = \frac{\text{Absorbance at } 1710 \text{ cm}^{-1}}{\text{Absorbance at } 2720 \text{ cm}^{-1}} \quad (2-12)$$

Base line technique<sup>(116)</sup> was used to calculate the absorbance of carbonyl group. This was done, as shown in Figure 2.2, by drawing a straight line (base line) tangential to adjacent absorption maxima or shoulders, then erecting a perpendicular through the analytical wavelength until it intersects with the base line.

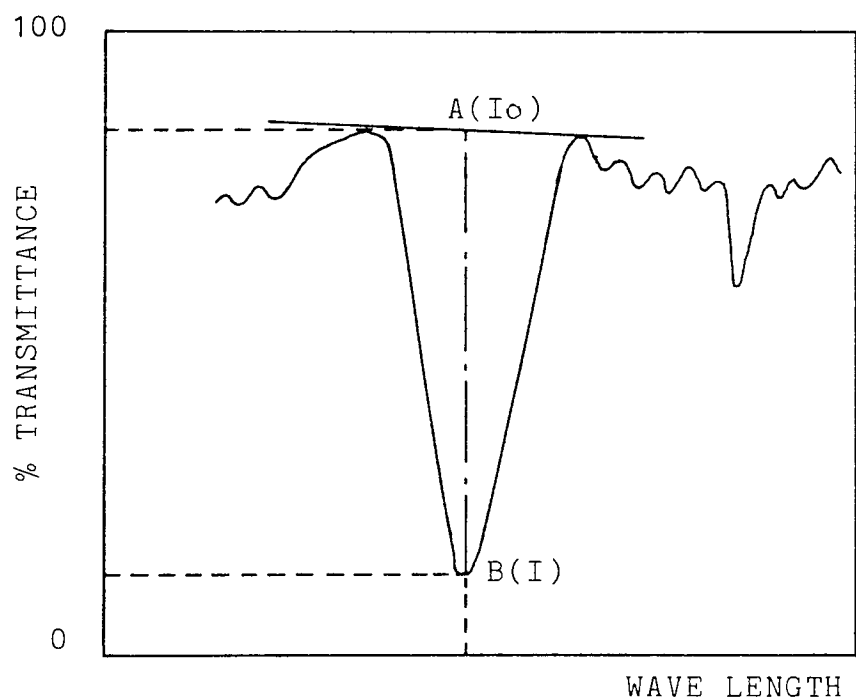

Figure 2.2 Base line technique<sup>(116)</sup>

Absorbance was calculated from the Beer-Lambert's equation<sup>(117)</sup>.

$$A = \log \frac{I_0}{I} \quad (2-13)$$

where: A = absorbance

$I_0$  = intensity of radiation effectively entering  
the sample, transmittance at point A.

I = intensity of radiation emerging from the sample,  
transmittance at point B.

### 2.3.9 Measurement of Impact Strength

The falling dart method was employed to measure the impact strength of polymer blend films, which involved subjecting specimens to impact by a falling dart of variable mass from a certain height. A relatively simple laboratory-made impact tester was used (Figure 2.3). It consisted of two metal blocks with concentric drilled holes in the middle. A metal pipe with a slit along its length was mounted directly above the hole of the upper metal block. A meter ruler was attached closely beside the pipe. Metal rods of different length (and therefore different weights) were used to act as falling darts.

To perform the impact test, the film was clamped between the two metal blocks. A ball-bearing was dropped from the top of the pipe to rest on the film. A suitable falling dart (metal rod) was supported by a spatula and the height

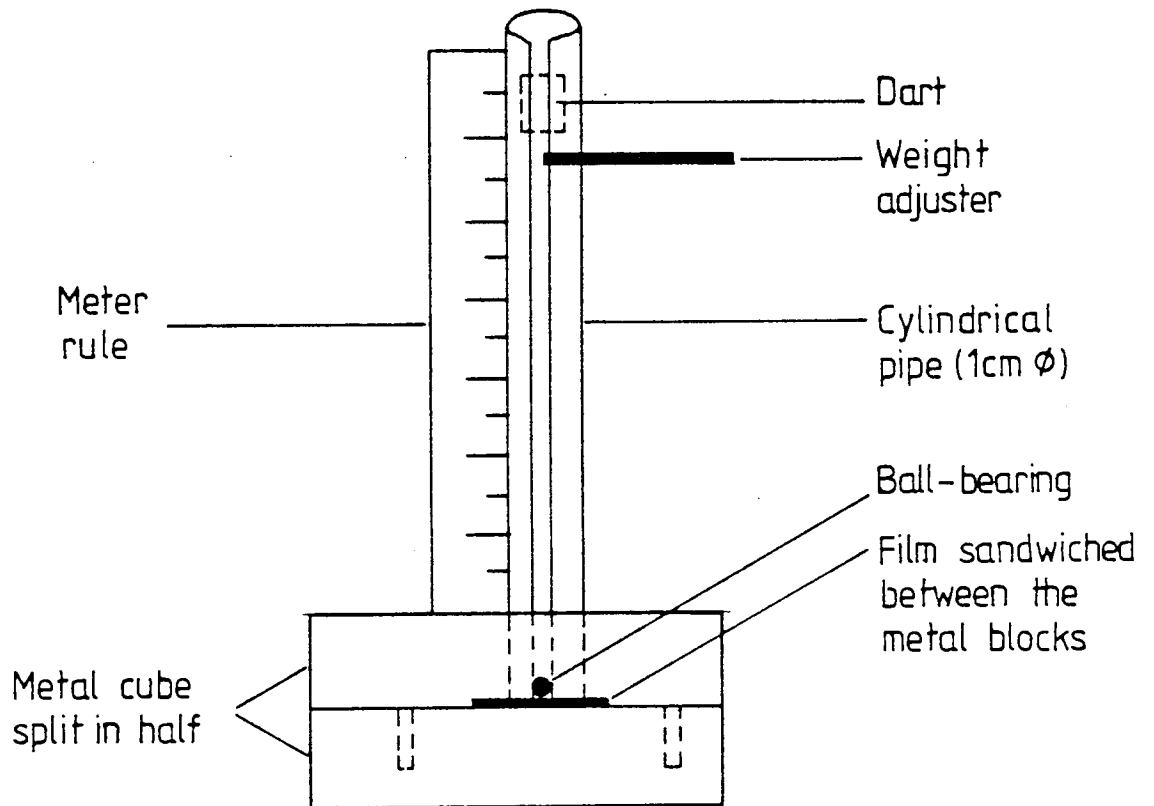

Figure 2:3 Laboratory-made falling dart impact tester.

adjusted before the dart was dropped on the ball-bearing. Each specimen area was subjected to only one impact, after which it was removed from the apparatus and visually examined<sup>(118)</sup>. If no failure has occurred, the mass of the dart was raised by one increment for the next specimen area. If the specimen has fractured or failed by ductile tearing, the mass was reduced by one increment. The impact resistance of the film would be the potential energy of the dart which would just break the film i.e.,

$$E = \text{impact resistance} = \frac{m \times g \times h}{t} \quad (\text{g.cm.sec}^{-2}) \quad (2-14)$$

where: m = mass of dart (g)

g = acceleration due to gravity (9.81 cm sec<sup>-2</sup>)

h = height of the dart (cm)

t = thickness of film (cm)

The mean of at least 5 subsequent trials for each sample was taken as the falling dart impact resistance.

### 2.3.10 Gel Permeation Chromatography (GPC)

Gel permeation chromatography analysis was kindly carried out by Polymer Supply and Characterisation, RAPRA, Shrewsbury, using Waters Associates Model 600 gel permeation chromatograph equipped with styragel columns connected in series.

The operating variables were as follows:

- (i) Four columns with exclusion limits of  $1 \times 10^6 \text{ \AA}$ ;  
 $1 \times 10^5 \text{ \AA}$ ;  $1 \times 10^4 \text{ \AA}$  and  $1 \times 10^3 \text{ \AA}$ .

- (ii) Flow rate of the mobile phase was  $1 \text{ ml min}^{-1}$ .
- (iii) The solvent used was tetrahydrofuran and ortho-dichlorobenzene.
- (iv) Concentration of test solution was 0.3% w/v.
- (v) The instrument was operated at  $140^{\circ}\text{C}$ .
- (vi) The calibration for the blend was derived from polystyrene. Mark-Howink constants were used for conversion via the universal calibration curve.

Polystyrene, in THF :  $K = 1.2 \times 10^{-4} \text{ m}^3 \text{ kg}^{-1}; \alpha = 0.71$   
 in ODCB :  $K = 1.38 \times 10^{-4} \text{ m}^3 \text{ kg}^{-1}; \alpha = 0.70$

Polypropylene, in ODCB :  $K = 1.03 \times 10^{-4} \text{ m}^3 \text{ kg}^{-1}; \alpha = 0.78$

Natural rubber in THF :  $K = 1.09 \times 10^{-4} \text{ m}^3 \text{ kg}^{-1}; \alpha = 0.79$

A digital computer was used to convert the information obtained from the chromatogram into a molecular weight distribution curve, with the calculation of all the molecular weight averages ( $\bar{M}_n$ ,  $\bar{M}_w$ ,  $\bar{M}_v$  and  $\bar{M}_z$ ) and the disparity ratios. A typical molecular weight distribution curve is shown in Figure 2.4.

### 2.3.11 Measurement of Glass Transition Temperature ( $T_g$ )

Differential Thermal Analysis (DTA) was used to measure the glass transition temperature ( $T_g$ ) of natural rubber-polypropylene blends. This is a technique which measures



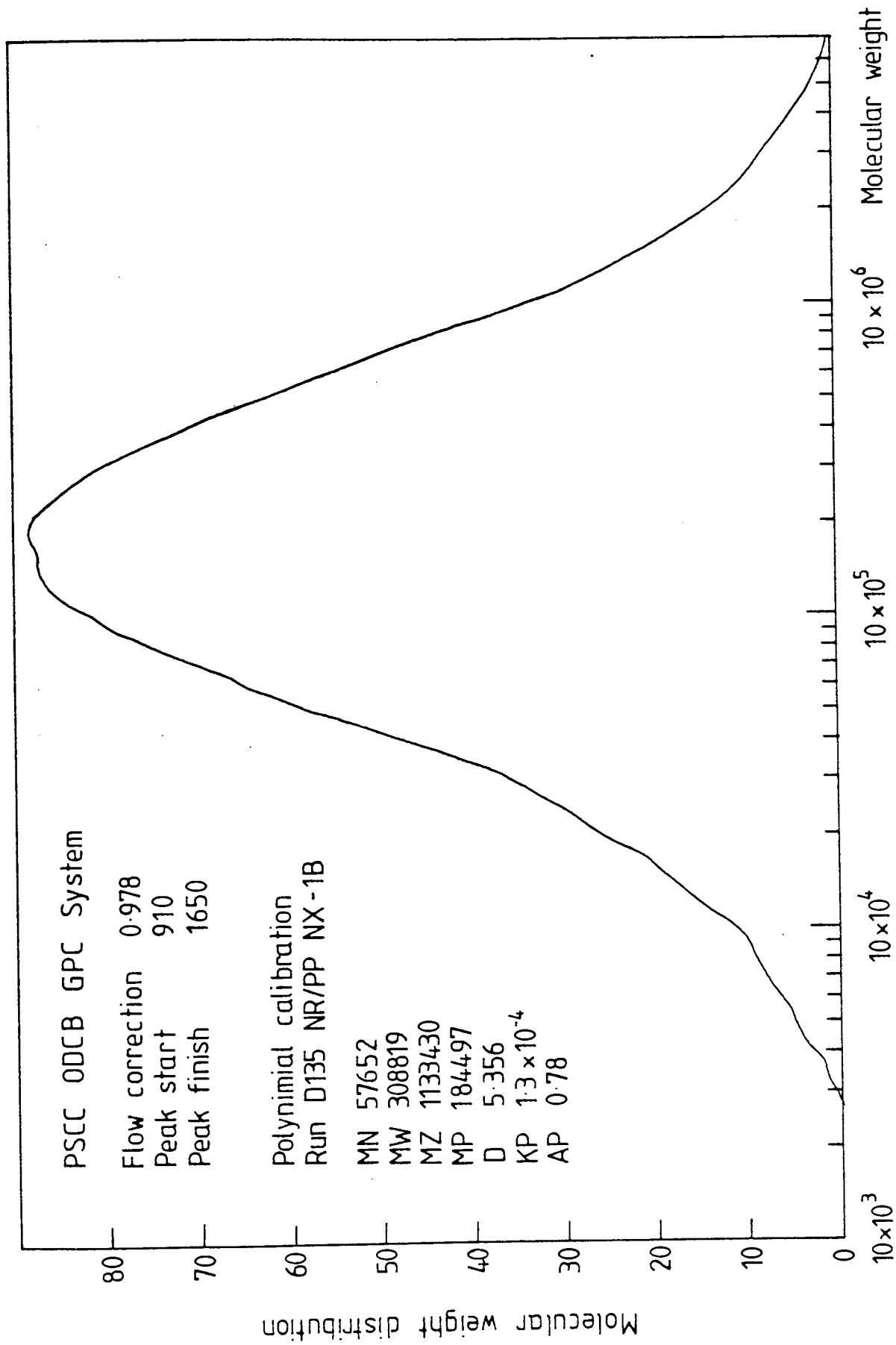

Figure 2:4 Typical molecular weight distribution.

the temperature difference ( $\Delta T$ ) between a sample and a reference material against either time or temperature<sup>(119)</sup> as the specimens are subjected to identical temperature conditions in an environment heated and cooled for a controlled time. The instrument used was a Stanton Red-Croft Differential Thermal Analysis Model 671 which comprises the following apparatus<sup>(120)</sup> (Figure 2.5):

- (i) Temperature programmer and head assembly
- (ii) Cooling equipment
- (iii) Amplifier
- (iv) A recorder, Servoscribe Recorder 571-20.

Films were cut out by a cork borer having a diameter of 5.5 mm and were weighed to about 10 mg. They were placed in sample dishes and sealed off to avoid air pockets between the dish and the sample. The sample dish was loaded onto the thermocouple platform by means of tweezers. The sample was placed on the left hand thermocouple platform and the reference dish on the right hand thermocouple platform in the head assembly. The heater assembly lid was put in position and the heater assembly was evacuated in order to remove air. Liquid nitrogen was passed through by opening the Kelvin Dewar Vessel to reach a temperature of  $-100^{\circ}\text{C}$ . The conditions of measurement were as follows:

The rate of temperature increase :  $20^{\circ}\text{C}/\text{min}$

Chart speed : 600 mm/hr

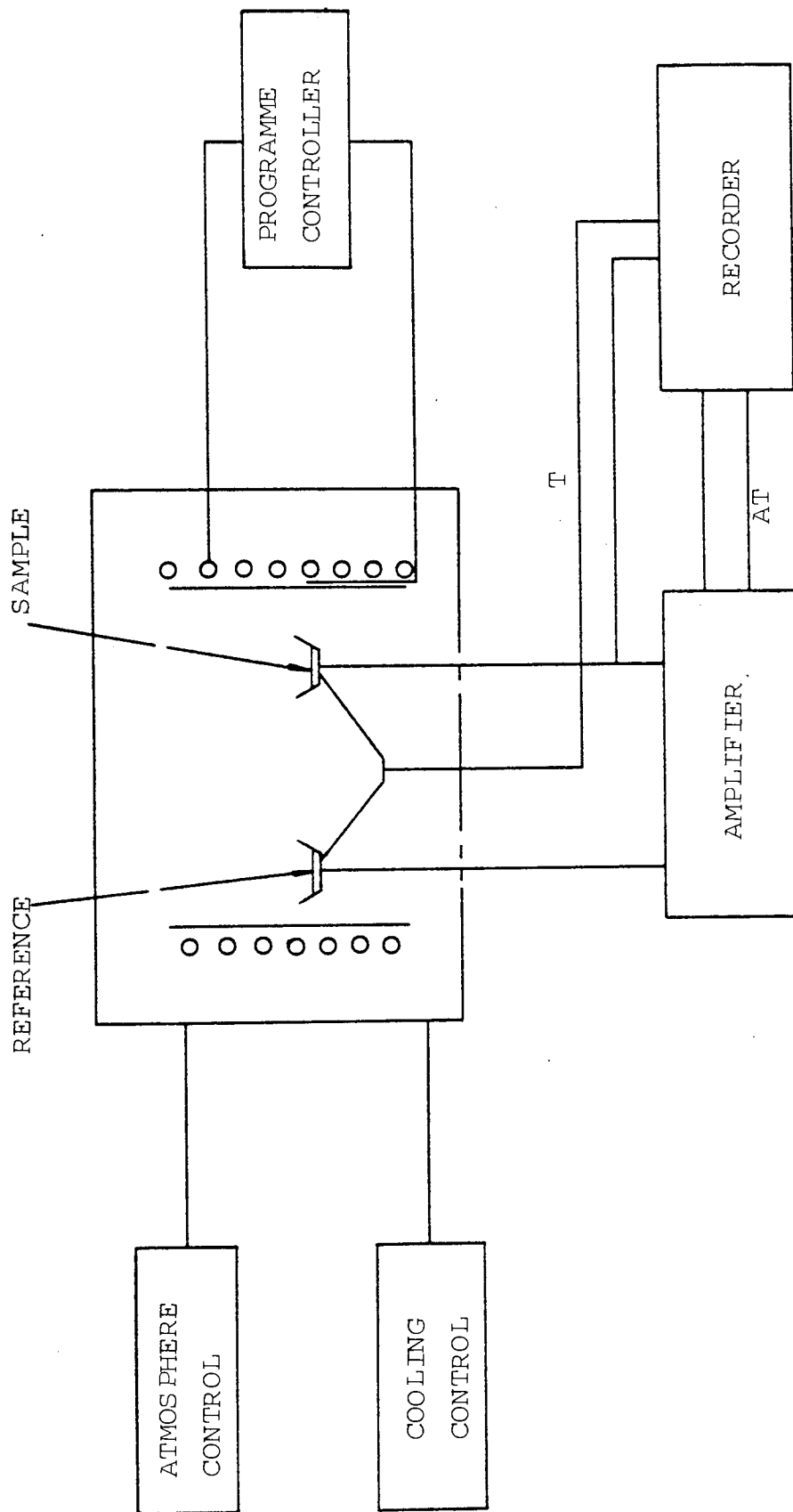

Figure 2:5 Schematic diagram of D.T.A.

Temperature scale	: 50 mV
Different temperature scale	: 5 mV
Reference material	: Alumina 12-20 m (BDH Chemicals)

As the temperature in the head assembly increased, changes in  $\Delta T$  were recorded by the recorder, and from these the glass transition temperature ( $T_g$ ) of the blends were calculated.

## 2.4 Testing For Injection Moulded Samples

### 2.4.1 Tensile Properties Test

Tensile properties test was carried out on a Hounsfield Tensile meter (Type E) using a cross-head speed of 0.5 in per minute. Tests were carried out on 6 samples from each run and the average result was taken. The nominal dimension of the dumb-bell test pieces was, length : 21.30 cm; width : 1.25 cm; thickness : 0.32 cm and gauge length : 7.00 cm. Tensile modulus, ultimate tensile strength and elongation at break were calculated as described in Section 2.3.1. Yield strength was calculated using the following equation:

$$\text{Yield strength} = \frac{\text{Force at yield}}{\text{Thickness} \times \text{Width}} \quad (\text{MPa}) \quad (2-16)$$

### 2.4.2 Flexural Properties Test

This test was carried out on a Hounsfield Tensile meter (Type E) using a 3-point fixture. The cross-head speed was 0.5 in per minute and the nominal dimension of the test specimen was, length : 12.45 cm; width : 1.26 cm; thickness : 0.32 cm and span : 5.00 cm.

From the stress-strain curve, the flexural strength and modulus were calculated using the following equations:

$$\text{Flexural strength } (\hat{\sigma}) = \frac{3PL}{2bd^2} \quad (\text{MPa}) \quad (2-17)$$

$$\text{Flexural modulus } (E) = \frac{P}{\delta} \times \frac{L}{3bd^3} \quad (\text{MPa}) \quad (2-18)$$

where: L = span length (5.00 cm)

P = force at maxima (N)

b = width (cm)

d = thickness (cm)

$\delta$  = beam deflection, and  $\frac{P}{\delta}$  was obtained from the graph by taking the tangent to the curve through the origin.

### 2.4.3 Measurement of Dynamic Mechanical Properties

The dynamic mechanical properties measured were shear modulus and mechanical damping ( $\tan \delta$ ) using a torsion pendulum (made

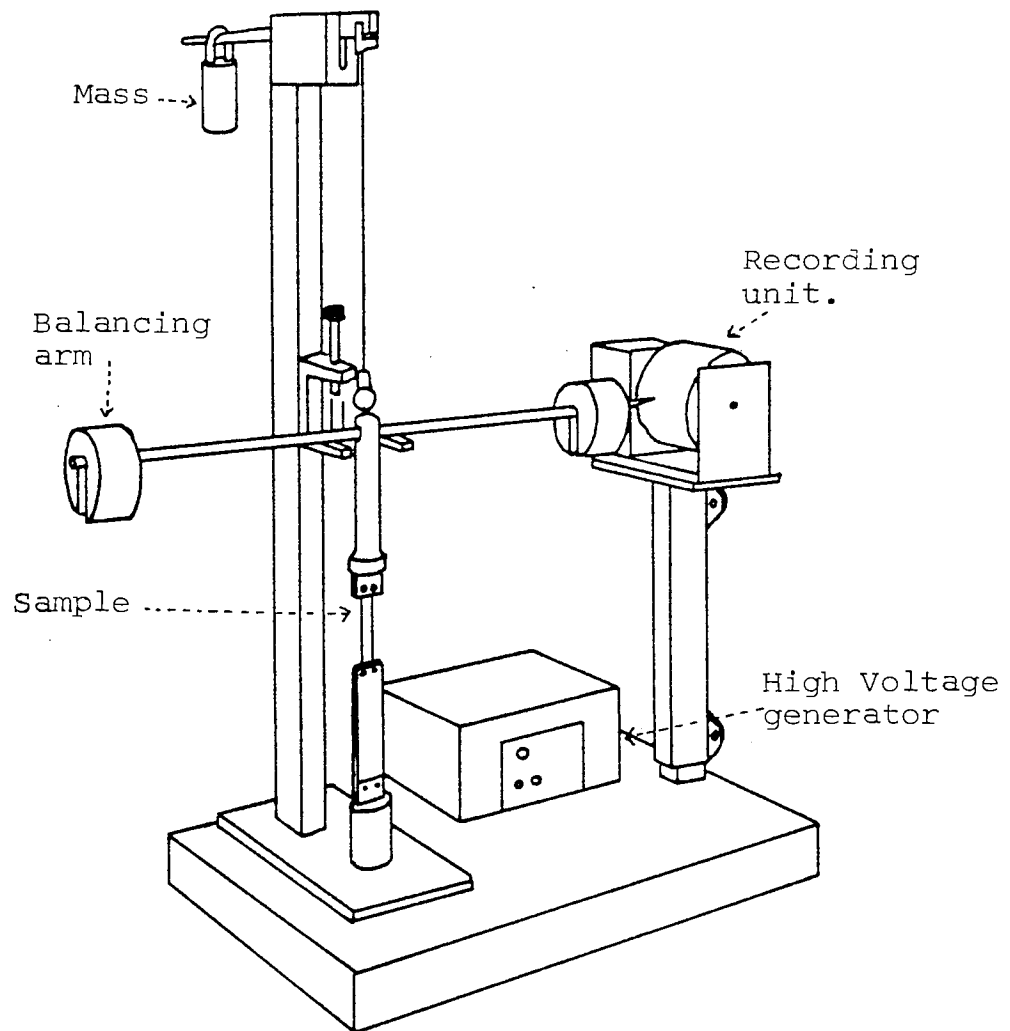

Figure 2:6 Torsion pendulum

by Nonius, Holland) which consists of three main parts<sup>(121)</sup>  
(Figure 2.6):

- (i) A bottom plate with two vertical columns.
- (ii) A torsion system with a cross-bar, auxiliary masses, a bearing device and a balancing arm.
- (iii) A recording unit with drum and high voltage generator.

The specimen bar having nominal dimension of: length : 4.47 cm; width : 0.65 cm and thickness : 0.32 cm was clamped into the clamps of the torsion system, and was oscillated with frequency of  $1.0 \text{ sec}^{-1}$ . The oscillation, which twisted and untwisted the specimen bar, was recorded on the rotating drum. The amplitude of oscillation decreased with time, because the damping gradually converted the mechanical energy of the system into heat (Figure 2.7).

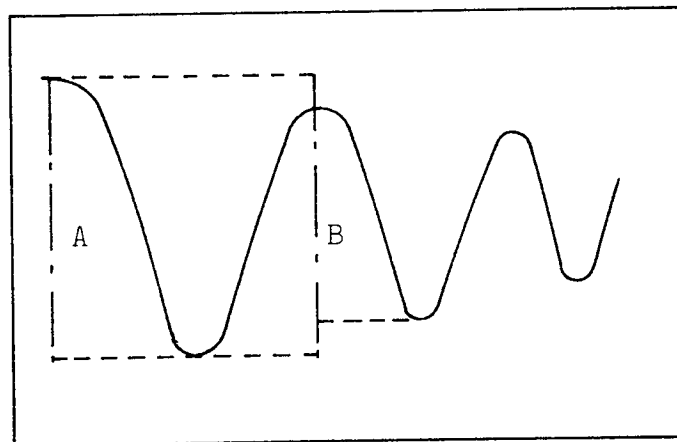

Figure 2.7 The oscillation curve

The decrement of oscillation ( $\Lambda$ ) was measured as A-B, and using the following equations, the shear modulus and mechanical damping ( $\tan \delta$ ) were calculated:

$$\text{Mechanical damping } (\tan \delta) = \frac{\Lambda}{\pi} \quad (2-19)$$

$$\text{Storage modulus } (G') = \frac{4\pi^2 \nu^2 IL}{g} \quad (2-20)$$

$$\text{Loss modulus } (G'') = G' \tan \delta \quad (2-21)$$

$$\text{Complex shear modulus } (G^*) = \sqrt{(G')^2 + (G'')^2} \quad (2-22)$$

where:  $\nu$  = frequency ( $\text{sec}^{-1}$ )

L = length of sample (m)

I = moment of inertia ( $\text{kgm}^2$ )

$\Lambda$  = log decrement  $\frac{\psi_n}{\psi_{n+1}}$

g = geometrical shape ( $Cbd^3$ ), when C is a dimensionless constant dependent on d

b = width (m)

d = thickness (m)

#### 2.4.4 Charpy Impact Test

The notched Charpy impact test involved a bar specimen rested on horizontal supports against two upright pillars, and was struck centrally by a pendulum<sup>(122)</sup> (Figure 2.8). The



subsequent swing of the pendulum measured the kinetic energy abstracted from the pendulum during the impact. The method is essentially a high speed three-point bending test. The bar specimen having nominal dimension of; length: 4.48 cm; width : 0.65 cm and thickness : 0.32 cm, was notched by a notching instrument to give a notch of 3.2 mm. It was placed on the horizontal supports with the notch away from the stricker. The load was put on the top of the stricker and when the stricker was swung, it strick the bar specimen. If the bar did not break, the load was increased. This was repeated until the bar was broken. The peak force was shown directly on the scale which indicated how far the stricker swung to break the bar specimen. The value of the scale, therefore, was converted into impact energy (I) using a standard calibration table. The measurement was repeated 5 times for each run and the average was taken. The Charpy impact strength was calculated using the following equation:

$$\text{Impact strength } (I_s) = \frac{I \times 1.35}{\text{width of sample}} \quad (\text{JM}^{-1}) \quad (2-23)$$

where: I = impact energy (ft lbs)

1.356 joules : 1 ft lb

#### 2.4.5 Scanning Electron Microscopy

This was used to examine the fracture surfaces of polymer

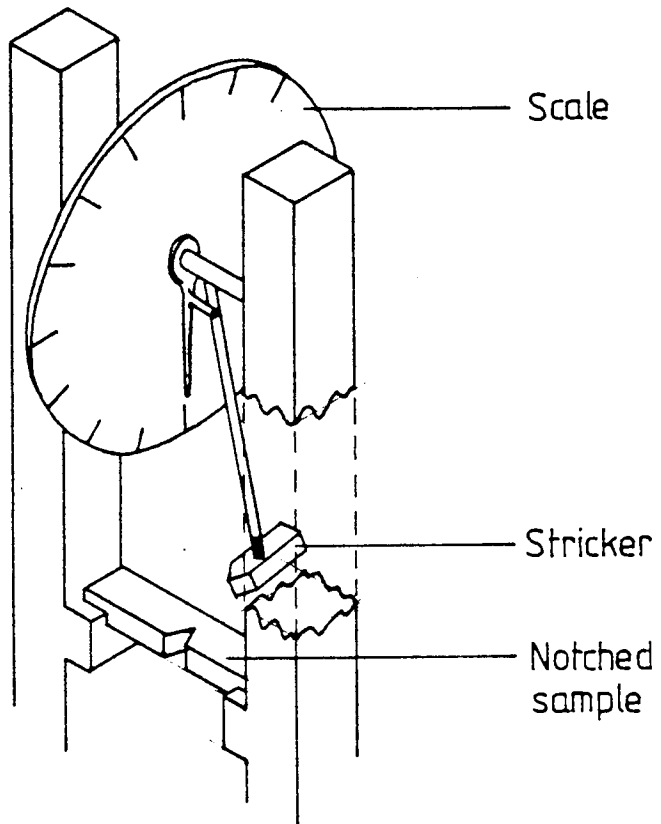

Figure 2:8 Charpy impact tester

blends after Charpy impact test in which the adhesive failure has occurred. The broken Charpy impact test specimens were cut with a sharp knife to give a 0.05 cm thick sample, which was then mounted (with the fractured surface facing upward) onto the sample mounting by means of double-face tape (Figure 2.9).

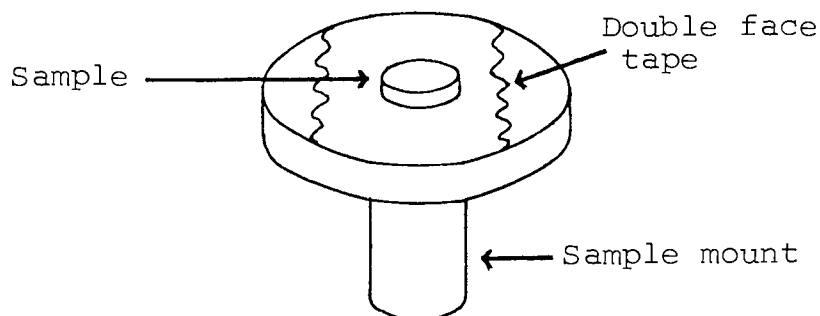

Figure 2.9 Sample for Scanning Electron Microscope

The specimens were vacuum-coated with a  $100 \text{ \AA}$  thin layer of gold. This coating will prevent charging in the electron beam since the samples were non-conductive material which causes very poor image in the photographs taken<sup>(123,124)</sup>. The samples were stored, before being examined in the Scanning Electron Microscope, in a dessicator to avoid condensation. The Scanning Electron Microscope used was a Cambridge S150. Photographs were taken with 200, 500 and 1000 times magnification.

#### 2.4.6 Oven-ageing

Oven-ageing tests were carried out in a Fisson oven with air circulation at temperatures of 50°C (7 days), 75°C (4 days) and 100°C (4 days). Samples were then tested for tensile properties, flexural properties and M.F.I.

CHAPTER THREE

PREPARATION OF NATURAL RUBBER-POLYPROPYLENE  
BLENDS BY MECHANICAL BLENDING

### 3.1 Objectives

The main objectives of this chapter are to investigate the effects of different proportions of natural rubber to polypropylene, the processing conditions, free radical initiator and solid phase dispersant on the mechanical properties of natural rubber-polypropylene blends. Natural rubber and stabilised polypropylene (HWM25) were blended in a Brabender Torque rheometer at different ratios: 70/30; 60/40; 50/50 and 40/60, and were processed at temperatures of 160°, 170° or 180°C for 5, 7 and 9 minutes in order to find the optimum conditions which produce a thermoplastic-rubber blend. Compression moulded samples were prepared as described in Section 2.2, and were tested for tensile properties (Section 2.3.1). The amount of bound natural rubber was calculated (Section 2.3.2) and this indicates the occurrence of any interpolymer reaction which takes place during the mixing of natural rubber with polypropylene. Molecular weight determinations, using Gel Permeation chromatography (Section 2.3.10), was carried out on all samples. A ratio of natural rubber to polypropylene of 60/40 was found to be the optimum. The effect of cross-linking agents (e.g., benzoyl peroxide and dicumyl peroxide) on the above blends was then investigated. Natural rubber-polypropylene (60/40) samples were blended in a Brabender torque rheometer at different temperatures (160°, 170°, 180°, 190° and 200°C). The speed of the torque rheometer was also varied from 60 to 110 rpm, at intervals of 10 rpm.

Processing was carried out in two different ways:

Method A. The rubber and polypropylene were blended for 3 minutes in a closed mixer before the addition of the crosslinking agent. Mixing was then allowed to proceed for a further 4 minutes<sup>(105)</sup> (total processing time 7 minutes).

Method B. Polypropylene was processed alone in a closed mixer for 3 minutes then natural rubber was added and processing was allowed to proceed for a further 2 minutes before the addition of the crosslinking agent. Mixing was continued for a further 7 minutes (total processing time of 12 minutes). The concentration of crosslinking agents was varied between 0 to 0.8 part per hundred of rubber (phr). Compression moulded samples were prepared as described in Section 2.2 and were tested for tensile properties (Section 2.3.1); percentage of bound natural rubber (Section 2.3.2); melt flow index (Section 2.3.5); melt rheology (Section 2.3.6); glass transition temperature (Section 2.3.11). Molecular weight determination (Section 2.3.10) was carried out for the soluble fraction of the blends in THF. The effect of EPDM on the natural rubber-polypropylene blends was studied. Natural rubber and polypropylene (weight ratio of 60 to 40) were mixed with different concentrations of EPDM in a Brabender torque rheometer at different temperatures for 7 minutes (Method A). In subsequent experiments, the processing time was extended to 8, 9, 10 and 11 minutes. Compression moulded samples were prepared as described in

Section 2.2 and were tested for tensile properties, percentage of bound natural rubber, glass transition temperatures and Melt Flow Index.

## 3.2 Results and Discussion

### 3.2.1 Optimisation

The effect of processing temperature, processing time and of varying the ratio of natural rubber to polypropylene in the blend on tensile properties is shown in Figures 3.1 to 3.3. It is clear that, in general, as the proportion of the polypropylene component increases, the tensile strength increases. Figure 3.4 summarises the effect of temperature and time on tensile strength, for 2 of the compositions studied. Blends processed at 160°C (Figure 3.1) produced a slightly higher tensile strength than those processed at 170°C and 180°C (Figures 3.2 and 3.3), and hence lower elongation at break. This may be due to the different reactions that occur during processing at different temperatures. When a solid polymer is subjected to high temperature and high mechanical shear, it passes initially through the rubbery phase during which macroradicals are formed by chain scission. In the presence of another polymer, these macroradicals will either interact with macroradicals of the same homopolymer or those of the second polymer<sup>(82)</sup>. In the case of natural rubber, low temperature produces higher shear rate due to its high



molecular weight. The higher the shear rate, the higher the extent of chain scission which can, in turn, affect the tensile properties adversely (Figure 3.5). At high natural rubber content (e.g., 70%), therefore, the shear force becomes higher and will tend to break down the polypropylene particles into small fragments and disperse them into the rubber matrix. Homogeneous dispersion of polypropylene particles in the rubber phase causes an increase in the tensile strength of the rubber since the polypropylene will act as a 'filler'. As polypropylene content increases, on the other hand, natural rubber becomes the discontinuous phase and becomes dispersed in the polypropylene matrix. Furthermore, the contribution of the natural rubber phase to the total viscosity of the blend becomes less and this, in turn, will change the nature of the reactions occurring during the mixing operation. Rubber-toughened plastic will probably be produced in this case and not thermoplastic rubber as expected.

Processing time has a less clear effect on the strength of the blends. However, in general, 7 minutes seems to give reasonable tensile strength (Figure 3.6). Therefore, a combination of a temperature of 160°C and processing time of 7 minutes was chosen as the optimum processing conditions. In order to choose the optimum composition of NR/PP which can produce a thermoplastic rubber, the tensile strength of blends processed at 160°C for 7 minutes was plotted against their elongation at break (Figure 3.7). It is clear from



Figure 3.7 that the tensile properties of the 50/50 and 40/60 NR-PP blends are typical of thermoplastics (i.e., high tensile strength and low elongation). This implies that the dominant phase for these compositions must be polypropylene. On the other hand, the tensile properties of the 70/30 blend are typical of uncrosslinked rubbers (i.e., low tensile strength and high elongation) implying that the dominant phase is natural rubber. It might be expected, therefore, that the inversion of phase dominance takes place at a composition of 60/40, in which a thermoplastic rubber may be obtained. This composition is, therefore, selected for subsequent preparation of natural rubber-polypropylene blends throughout all experiments.

The amount of bound natural rubber to polypropylene at different NR/PP ratios is plotted against processing time at different temperatures (Figures 3.8, 3.9 and 3.10). It is clear that the amount of bound natural rubber decreases with increasing the polypropylene content in the blend. This may be due to the contribution of natural rubber to the viscosity of the blends. As the content of natural rubber decreases, the viscosity of the blends decreases resulting in less shear, which will subsequently lead to less breakdown of the rubber or polypropylene molecules. Thus, the possibility of producing macroradicals becomes limited and this will result in less bound natural rubber. However, there appears to be no good correlation between the amount of bound natural rubber and the tensile strength

of the blend. This indicates the independence of tensile properties on the amount of bound natural rubber. In these blends, the reinforcement is provided by the polypropylene domains which function rather like the chemical crosslinks in vulcanised rubber, while the rubber phase gives flexibility. Therefore, the dispersion of the polypropylene domains in the rubber phase for blends which have high rubber content is the most important factor determining the tensile properties. The processing temperatures seem to have only a minor effect on the amount of bound natural rubber.

Changes in molecular weight of the extracted natural rubber-polypropylene blends (in petroleum ether) are shown in Figures 3.11 to 3.13. Figure 3.14 summarises changes in molecular weight of 2 different blends studied during processing. It is clear that at high rubber content, the weight average molecular weight ( $\bar{M}_w$ ) decreases with increasing processing temperatures and processing time. At high polypropylene content, on the other hand, the change of molecular weight with processing time is quite small. Moreover, the molecular weight of the blends under these conditions is lower. The increase in polypropylene content, which itself has lower molecular weight ( $\bar{M}_w: 3.2 \times 10^5$ ), will automatically reduce the molecular weight of the blends. The implication of this is that interpolymer formation which is expected to occur during blending is, to some extent, limited since the shear force, which is an important factor contributing to the production of macro-

radicals, is less. Furthermore, NR is more susceptible to thermal degradation than polypropylene. Therefore, when natural rubber content in the blend is high (e.g., 70/30; Figure 3.14) the thermal degradation which occurs during processing, is higher at longer processing times and higher temperatures. Degradation may occur in the rubber phase as well as in the formed interpolymer.

The above results show clearly that the correlation between the interpolymer formation, which is expected to increase the 'compatibility' of the two polymers in the blends, with the physical properties is very ambiguous. This may be due to the amount and location of the interpolymer itself in the blends. In this work, therefore, since the amount of bound natural rubber formed in the blend (see Figures 3.8 to 3.10) is very small, the interpolymer cannot act as a good solid phase dispersant for these blends.

### 3.2.2 Effect of Free Radical Initiator on the Properties of NR/PP Blends

#### 3.2.2.1 Processing by Method A

The effect of benzoyl peroxide as free radical initiator on the tensile properties of natural rubber-polypropylene blends is shown in Figures 3.15 and 3.16. The highest tensile strength for the blends when processed at 160°C is 4.6 MPa. The appearance of the blends, however, changes

when the concentration of benzoyl peroxide is increased. At concentrations above 0.5 phr, the blends seem to be very weak and crumbly, and are very difficult to compression mould. The lumps of rubber phase are very obviously observed. Figure 3.16 shows that at all temperatures, the elongation at break of the blends stays almost constant up to a peroxide concentration of 0.2 phr. At higher concentrations the elongation at break gradually increases indicating that the blends are more elastic. The amount of bound natural rubber to polypropylene is shown in Figure 3.17. It is apparent that the binding of natural rubber is not affected by increasing the concentration of benzoyl peroxide. This indicates that the peroxide does not promote partial grafting nor interpolymer formation between the two phases. Moreover, the processing temperature has no effect on such a reaction.

Glass transition temperature ( $T_g$ ) of the polymer blend can be used for determination of compatibility of the polymers. It can also give an indication as to whether interpolymerisation has taken place during the blending process<sup>(125)</sup>. In the case of a compatible polymer system, the polyblend should show either one transition temperature only, or an intermediate transition temperature which emerges between the two transition temperatures of the parent polymers. In the case of natural rubber and polypropylene blends which are processed in the presence of peroxide, one would expect an interpolymer formation and hence an intermediate glass

transition temperature. Figure 3.18 shows that there is no change in the Tg of natural rubber-polypropylene blends with increasing concentration of benzoyl peroxide. This implies that the bound natural rubber does not affect the glass transition of the blends. Figure 3.19 is a typical DTA graph showing the Tg of the rubber ( $\sim 65^{\circ}\text{C}$ ), the Tg of PP ( $\sim 10^{\circ}\text{C}$ ) and no intermediary peaks in the blend. It is clear therefore, that benzoyl peroxide is not an effective free radical initiator, because it does not improve the tensile properties, nor does it affect the binding of natural rubber to polypropylene or the glass transition temperature (Tg).

The effect of dicumyl peroxide as a free radical initiator on the properties of natural rubber-polypropylene blends is shown in Figures 3.20 to 3.24. Figure 3.20 shows the variation of tensile strength of natural rubber-polypropylene blends with the concentrations of dicumyl peroxide and processing temperatures. It is obvious that dicumyl peroxide has a very remarkable effect on the tensile strength of the blends. The tensile strength of the blends processed at  $160^{\circ}\text{C}$  and  $170^{\circ}\text{C}$  show a similar trend, where they increase with increasing concentration of dicumyl peroxide. For blends processed at  $160^{\circ}\text{C}$ , concentration of peroxide of 0.4 phr gives maximum tensile strength with an increase of 27% compared to the control. Blends processed at  $170^{\circ}\text{C}$  show an increase of 57% for a concentration of dicumyl peroxide of 0.3 phr. Blends processed at  $180^{\circ}\text{C}$  show a gradual increase of tensile strength with increasing concentration

of dicumyl peroxide. Maximum tensile strength is reached at a peroxide concentration of 0.5 phr. Figure 3.21 summarises the tensile strength of blends in the presence and absence of benzoyl and dicumyl peroxide at different temperatures. Elongation at break of the blends decreases with increasing concentration of dicumyl peroxide (Figure 3.22). This could be due to the high crosslinking density of the rubber phase which, in turn, gives rise to higher viscosity resulting in poor dispersion. The appearance of the blends at high concentration of peroxide which becomes crumbly after compression moulding supports this. This assumption is also strengthened from results of the bound natural rubber (Figure 3.23) and that of Melt Flow Index (MFI) (Figure 3.25). Figure 3.23 shows that the amount of bound natural rubber increases with increasing concentration of dicumyl peroxide. This suggests that a chemical reaction may have taken place during the blending process. Blends processed at 170°C gave the highest amount of bound natural rubber. Therefore, this temperature was chosen as the optimum temperature to produce good blends. Figure 3.24 summarises the extent of bound natural rubber in the presence and absence of different peroxides. Figure 3.25 shows changes in Melt Flow Index (MFI) with dicumyl peroxide concentration. The processing temperature effect is minimal. As the concentration of dicumyl peroxide is increased, the melt flow index decreases sharply. This suggests that the dicumyl peroxide may promote certain reactions giving rise to higher viscosity of the blends.

From these observations, the major question which arises is why the increase in the bound natural rubber content and the decrease in MFI values do not contribute to improving the tensile properties of the blends. It can then be suggested that the 'bound natural rubber' determined is not in the form of an interpolymer, but may have resulted from a chemical reaction (crosslinking) in the rubber phase itself, without any participation from the polypropylene phase. At higher concentration of the peroxide more crosslinks in the rubber phase can occur and higher degree of degradation of the counterpart polymer (polypropylene) may take place. This may account for the likely reactions responsible for the effect on tensile properties.

The degradation of polypropylene phase could be due to two factors; an increase in viscosity of the blends and the effect of peroxide on polypropylene phase. An increase in viscosity of the blends due to an increase in bound or crosslinked natural rubber will produce high shearing forces resulting in a greater degree of degradation of polypropylene component. As the level of degradation increases, the blend becomes weaker as shown by the tensile properties results (Figures 3.20 and 3.21). The effect of higher peroxide concentration on polypropylene is known to increase the degradation level of the polymer during high temperature processing under high shear forces<sup>(126)</sup>. The peroxy radicals formed will abstract a hydrogen from polypropylene to give rise to another macroradical which is susceptible to further degradation (Scheme 3.1).



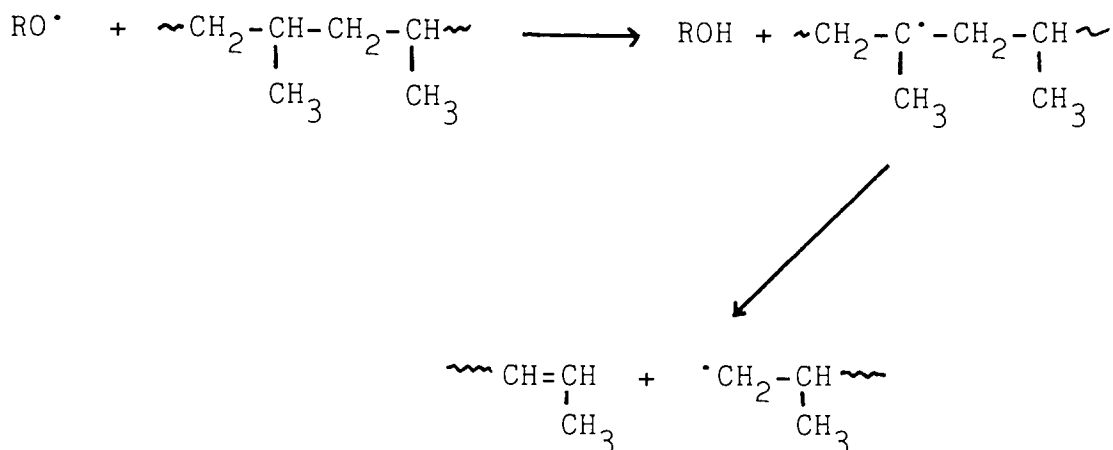
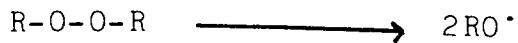

Scheme 3.1 Chemical reactions of polypropylene in the presence of peroxide

Melt rheology and molecular weight measurements lends further support to this. Figures 3.26, 3.27 and 3.28 show changes in viscosity of blends containing different concentrations of dicumyl peroxide with shear rates. It is clearly seen that as the concentration of dicumyl peroxide increases, the viscosity increases. This must be due to a partial crosslinking in the rubber phase which produces an increase in viscosity<sup>(127)</sup>. It is also clear that the viscosity decreases dramatically with increasing shear rates, especially for blends which have higher viscosity. At higher shear rate ( $\log \dot{\gamma} = 1.75$ ) viscosities of blends containing more than 0.2 phr of dicumyl peroxide are similar (Figure 3.26)(the higher the viscosity, the higher the degree of breakdown of polypropylene). Figure 3.29 shows the effect of varying concentration of dicumyl peroxide and

processing temperatures on the molecular weight ( $M_n$ ) of natural rubber-polypropylene blends. It is seen that the number average molecular weight of the blends decreases with increasing concentration of dicumyl peroxide. Since these measurements were carried out on the soluble fraction of the blends (see Section 3.2A) which are mostly propylene fraction, it seems that this fraction has undergone some degradation. Processing temperatures also contribute to an increase in degradation.

Figure 3.30 shows the effect of dicumyl peroxide on the melt flow index of natural rubber and polypropylene processed separately. This indicates that when natural rubber is processed with dicumyl peroxide as crosslinking agent, it produces a crosslinked phase (gel formation), whilst polypropylene undergoes degradation (chain scission). The melt flow index of natural rubber decreases with increasing concentration of dicumyl peroxide while that of polypropylene increases. It is apparent that gel content in natural rubber increases with increasing concentration of dicumyl peroxide and the gel-free remaining solution shows a decrease in its molecular weight (Figure 3.31). This means that a higher molecular weight fraction in natural rubber is formed with increasing concentration of dicumyl peroxide. While for polypropylene, there is no gel formed, and all the polypropylene completely dissolves in THF. The weight average molecular weight of polypropylene decreases with increasing concentration of dicumyl peroxide. Therefore, when natural rubber and polypropylene are blended in the

presence of dicumyl peroxide, the peroxide shows two superimposed effects: (1) a reduction in MFI due to the cross-linking process in the rubber phase and (2) an increase in MFI (Figure 3.29) (reduction in molecular weight, Figure 3.30) of polypropylene due to a degradation process. Since the proportion of natural rubber is higher than that of polypropylene (ratio 60/40), the first effect seems to be more dominant as shown in the MFI (Figure 3.29). However, the second effect is likely to be more important in determining the tensile properties of the blend since in this particular thermoplastic rubber blend the strength relies on the polypropylene phase<sup>(106)</sup>.

Figure 3.20 shows that processing temperature of 190°C, processing time of 7 minutes and dicumyl peroxide concentration of 0.3 phr give the highest tensile properties of NR-PP blends. These conditions, therefore, were used in processing method A for subsequent experiments since the correlation between interpolymer formation and tensile properties is very ambiguous. Further experiments were undertaken to improve the properties of the blends which are based on the assumption that homogeneity of dispersion may be the most important factor. These experiments involved firstly extending the processing time and secondly increasing the processing temperatures but in order to avoid further degradation, an antioxidant NONOX WSP was used.

Figure 3.32 shows the effect of extending processing time on the tensile properties of blends containing 0.3 phr of

dicumyl peroxide. The trends for tensile strength of the blends processed at different temperatures are similar, they increase to reach a maximum and then dramatically decrease. Blends processed at 160°C reach the highest value for its tensile strength after 10 minutes while the corresponding blends which are processed at 170° and 180°C reach their maxima after 9 minutes. The effect of temperature on elongation at break of the blends is less dramatic. Figure 3.32 shows the effect of high processing temperatures and dicumyl peroxide in the presence of an antioxidant on the tensile properties of blends processed for 7 minutes. It is apparent that high processing temperatures (in the presence of an antioxidant) do not improve the tensile properties of the blends. This provides convincing evidence that high processing temperatures cause degradation to a greater extent. This is further supported by results of molecular weight determination (Figure 3.34). It is clear that the combined effect of dicumyl peroxide and high temperatures decreases the  $\bar{M}_n$  of the blends.

Based on these results, the following processing conditions were chosen as optimum to produce good thermoplastic rubber blends which have high tensile properties (T.S.:6.6 MPa); processing temperature 160°C; dicumyl peroxide concentration 0.3 phr and processing time 10 minutes. This condition was applied for processing method A in later experiments. The effect of torque speed on the properties of natural rubber-polypropylene rubber processed under the above conditions is shown in Figures 3.35 to 3.37. Figure 3.35 shows

that tensile strength of the blends decreases with increasing torque speed. This suggests that the shear rate also has an effect on the mechanical properties; the material becomes weaker, as exhibited from its elongation at break, at higher torque speed. This may be due to higher degree of degradation caused by more chain scission at these higher shear rates. Melt flow index (MFI) and melt rheology results also support this (Figures 3.36 and 3.37). Figure 3.36 shows that melt flow index of the blend increases with increasing torque speed, indicating a decrease in viscosity. This is supported by the melt rheology result (Figure 3.37), in which the decrease in viscosity becomes obvious with increasing the torque speed. In order to complete the processing conditions in Method A, the torque speed of 60-70 rpm was therefore used.

#### 3.2.2.2 Processing by Method B

The effect of the addition sequence of the components in the blending process on the properties was also investigated. Polypropylene was processed first for 2 minutes (until it melted) followed by the addition of natural rubber. Figure 3.38 shows the variation of the tensile strength with dicumyl peroxide concentration for blends processed at 160°C, 170°C and 180°C and a torque speed of 70 rpm. Blends processed at 180°C exhibit a different blend than those processed at lower temperatures. At 180°C, tensile strength increases by c.a. 10% at concentrations of dicumyl peroxide

of 0.2 phr and then decreases with increasing concentration of peroxide. Elongation at break at 160° and 170°C decreases with increasing peroxide concentration as expected (Figure 3.39). However, for blends processed at 180°C, it seems that both tensile strength and elongation at break decrease with increasing concentration of dicumyl peroxide. This shows that high temperature causes degradation leading to inferior properties. The rheological behaviour of blends processed by Method B is shown as a plot of viscosity versus shear rate (Figures 3.40 to 3.42). It is clear that the increase in viscosity, with increasing concentration of dicumyl peroxide, for blends processed at 180°C is less profound when compared to blends processed at lower temperatures. This behaviour seems to be reflected in the tensile properties (Figure 3.38) and proves that high viscosity does not lead to improvement in the properties. The super-imposed effects as described earlier (i.e., reduction in melt flow index in the rubber phase and increase in melt flow index in the polypropylene phase), should always be taken into account. Therefore, for processing method B, the optimum conditions used in subsequent experiment are dicumyl peroxide concentration of 0.6 phr and processing temperature of 170°C. Table 3.1 compares the behaviour of blends obtained by optimum conditions used in processing methods A and B. It is seen that in terms of processing time and dicumyl peroxide concentration, processing method A is preferred and therefore was used for further experiments.

PROCESSING	MODE A	MODE B
Dicumyl peroxide conc (phr)	0.3	0.6
Processing temperature (°C)	160	170
Processing time (mins)	10	12
<u>Properties:</u>		
Tensile strength (MPa)	6.6	6.7
Elongation at break (%)	275	200
Tensile modulus (MPa)	55	60
<u>Melt properties:</u>		
Melt flow index (g/10mins)	1.6	0.6
Viscosity (poisse) at low shear rate (0.544 sec )	38,018	56,234

Table 3.1 - Comparison in the properties of NR/PP (60/40) blends processed in Method A and B.

### 3.2.3 Effect of Ethylene-propylene Rubber (EPDM) on the Properties of Natural Rubber-polypropylene Blends

Figure 3.43 shows the effect of varying concentration of EPDM and processing temperatures on the tensile strength of the blends. It can be seen that the tensile strength increases with concentration of EPDM up to 3.0% in every blend before it decreases with further increase in EPDM concentration. Processing temperatures have less dramatic effect, Figure 3.44 shows the consequent variation of elongation at break. As expected, the elongation at break increases commensurately with decreasing tensile strength as the concentration of EPDM increases. However, up to 4.0% EPDM, the elongation at break does not vary to any extent. The decrease in tensile strength and the increase in elongation at break with increasing concentration of EPDM must be due to the increase in the rubber phase where the blends are more typical of unvulcanised rubber having low tensile strength and high elongation at break. This is also seen in the MFI of these blends (Figure 3.45). The MFI decreases with increasing concentration of EPDM which implies that the viscosity of the blends increases due to the high molecular weight of EPDM.

The addition of EPDM into binary blends of natural rubber and polypropylene seems not to affect the binding of natural rubber to polypropylene, since there has been no significant increase in the bound natural rubber content (Figure 3.46).



The result from the glass transition temperature ( $T_g$ ) measurement also shows no evidence of an increase in binding of natural rubber nor is there any change in the  $T_g$  of the blends with increasing concentration of EPDM (Figure 3.47). This could be due to the failure of EPDM to increase the adhesion between rubber and polypropylene phases, even though EPDM has a similar parafinic structure with polypropylene. Therefore, EPDM does not act as solid phase dispersant for this particular blend.

3% of EPDM gave the highest tensile strength for these blends, hence was used in further experiments. Figure 3.48 shows the effect of extending processing time and combination of 3% EPDM and 0.3 phr dicumyl peroxide on the tensile properties of the blends. Extending the processing time to 9 minutes seems to increase significantly the tensile strength of blends processed at  $160^{\circ}\text{C}$  and  $180^{\circ}\text{C}$ . However, when these results are compared with the corresponding blends without EPDM (processed under the same conditions (Figure 3.30)), the results are seen to be inferior. Therefore, the addition of EPDM into binary blends of natural rubber-polypropylene economically and technologically is not efficient enough to improve the performance of the blends.

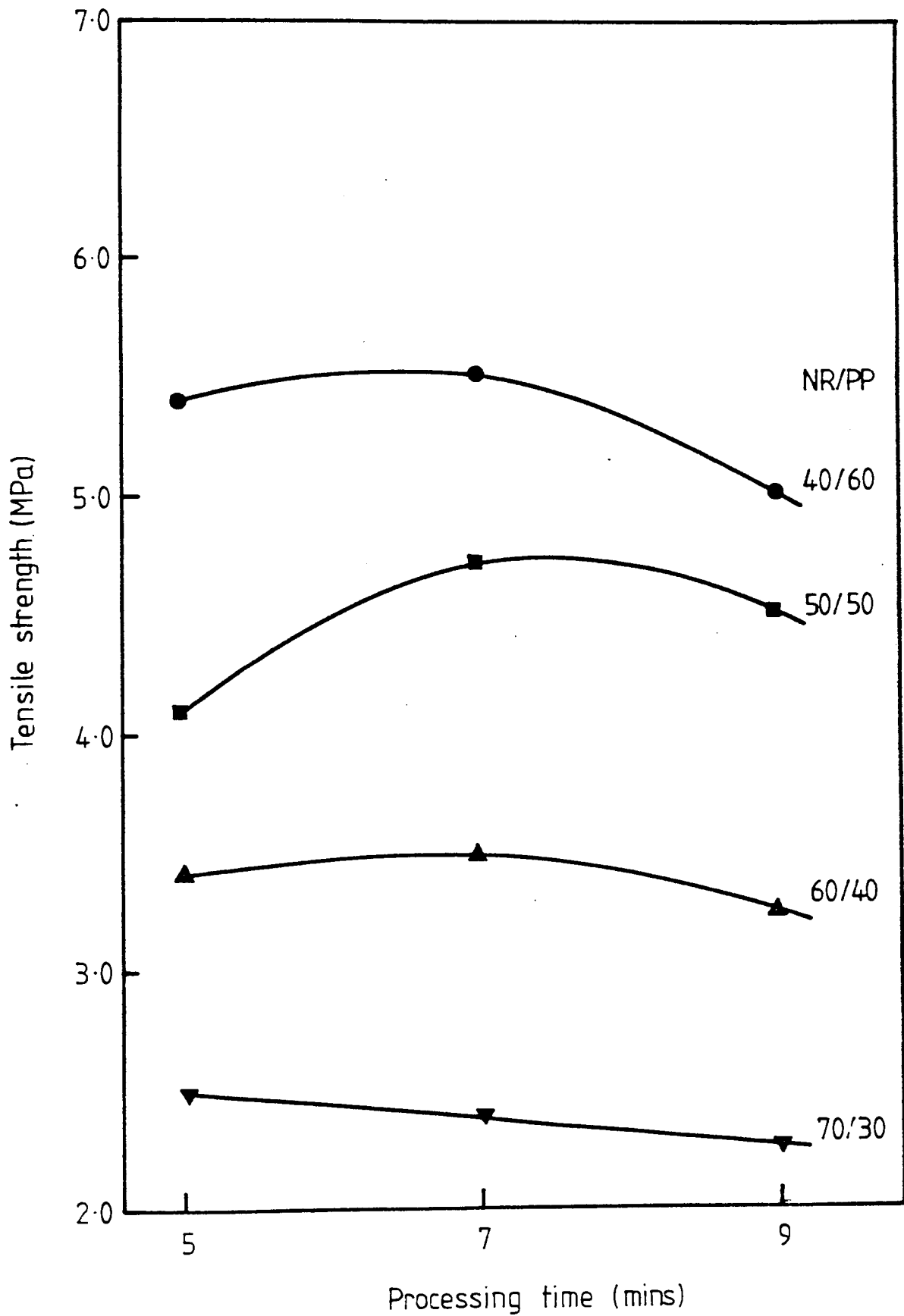

Figure 3.1 - variation of tensile strength with processing time for NR/PP blends, processed at 160°C in Brabender Torquerheometer.

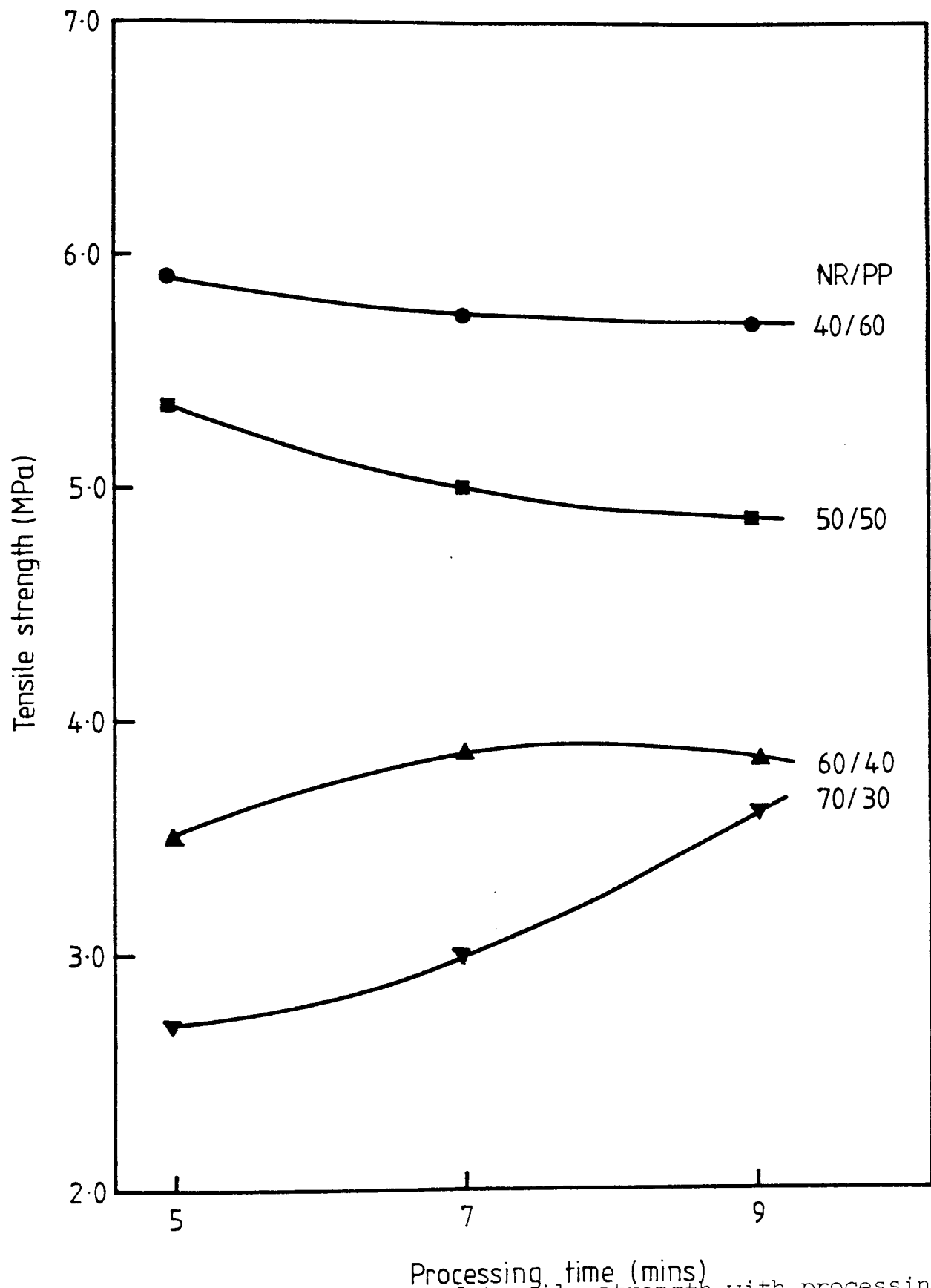

Figure 3.2 - Variation of tensile strength with processing time for NR/PP blends, processed at 170°C in a Brabender Torquerheometer.

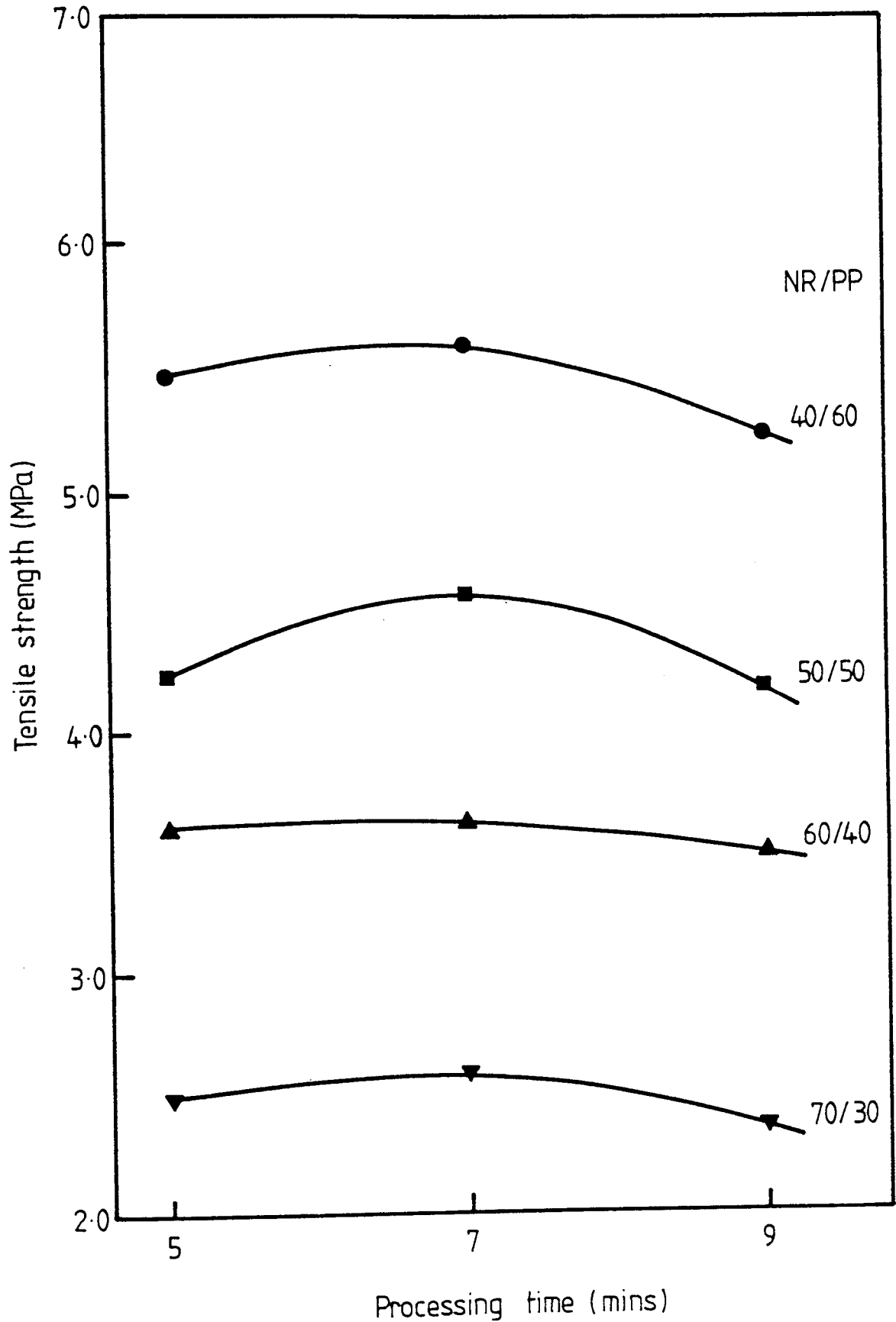

Figure 3.3 - Variation of tensile strength with processing time for NR/PP blends, processed at 180°C in a Brabender Torquerheometer.

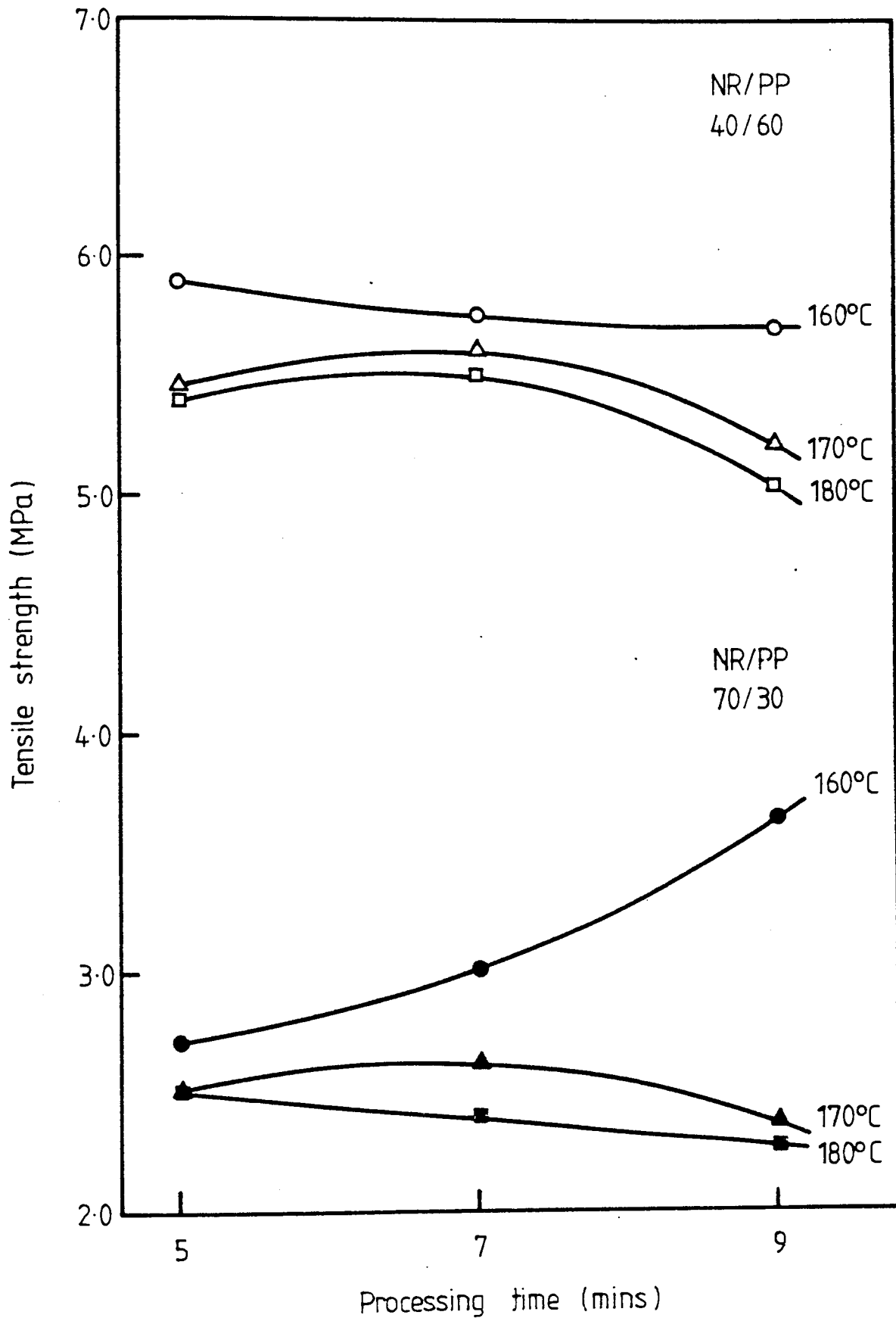

Figure 3.4 - Summary of the effect of processing temperature and time on the tensile strength of two blends composition studied (Processed in Brabender Torquerheometer).

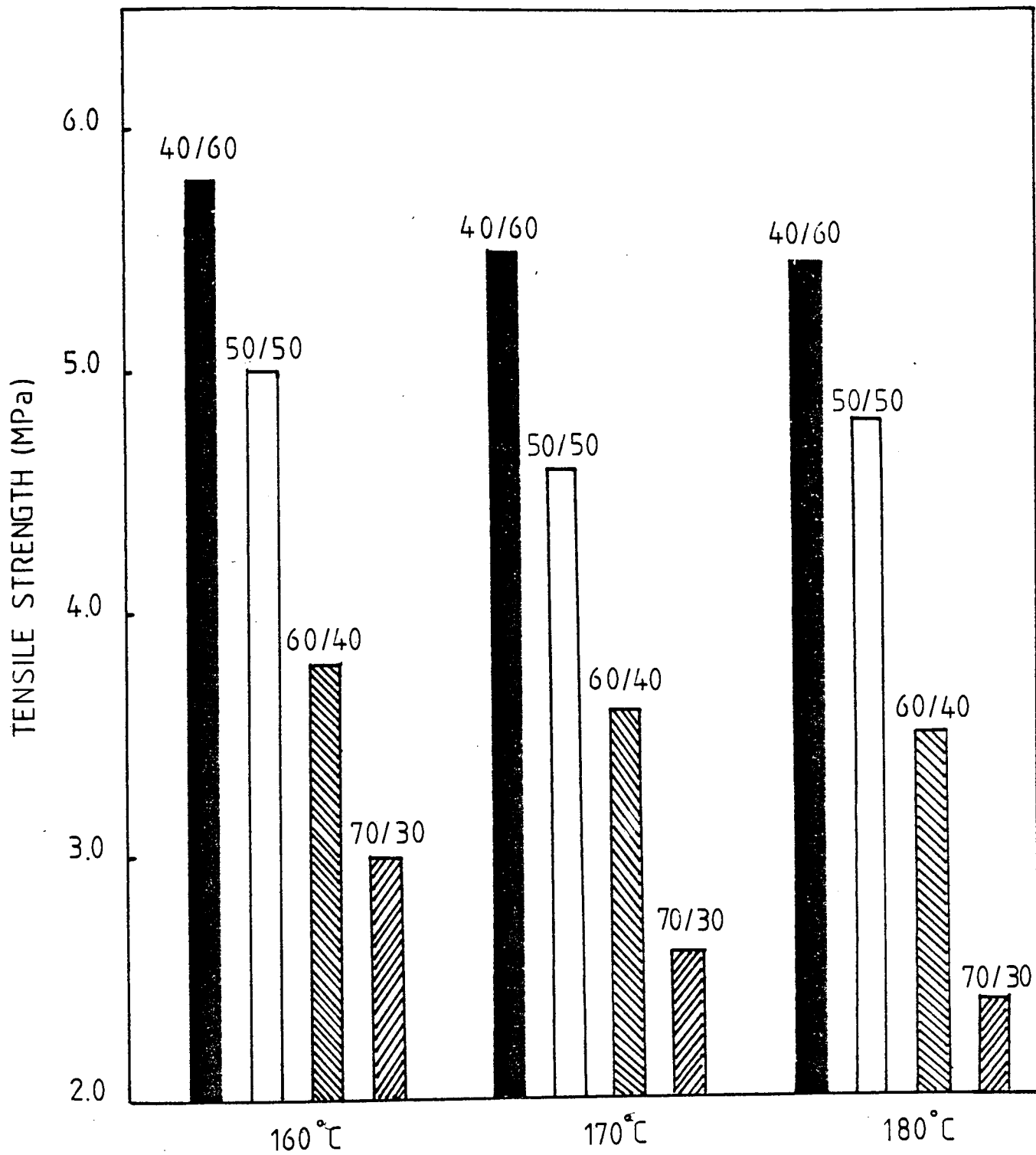

Figure 3.5 Effect of processing temperatures and ratios of natural rubber to polypropylene on the tensile strength of NR/PP blends processed in a Brabender Torquerheometer for 7 minutes.

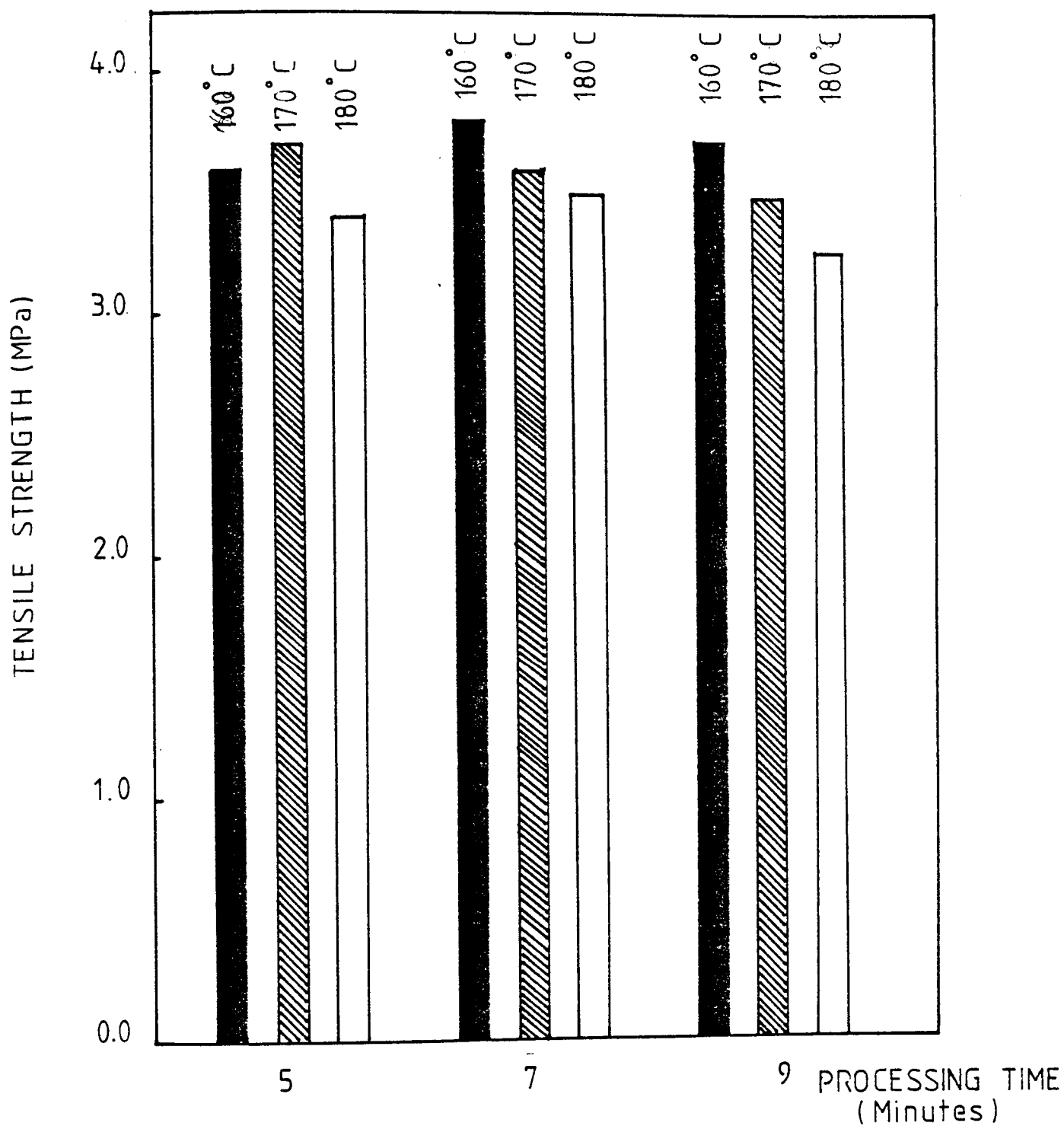

Figure 3.6 Effect of processing time and temperature on the tensile strength of NR/PP blends processed in a Brabender Torquerheometer.

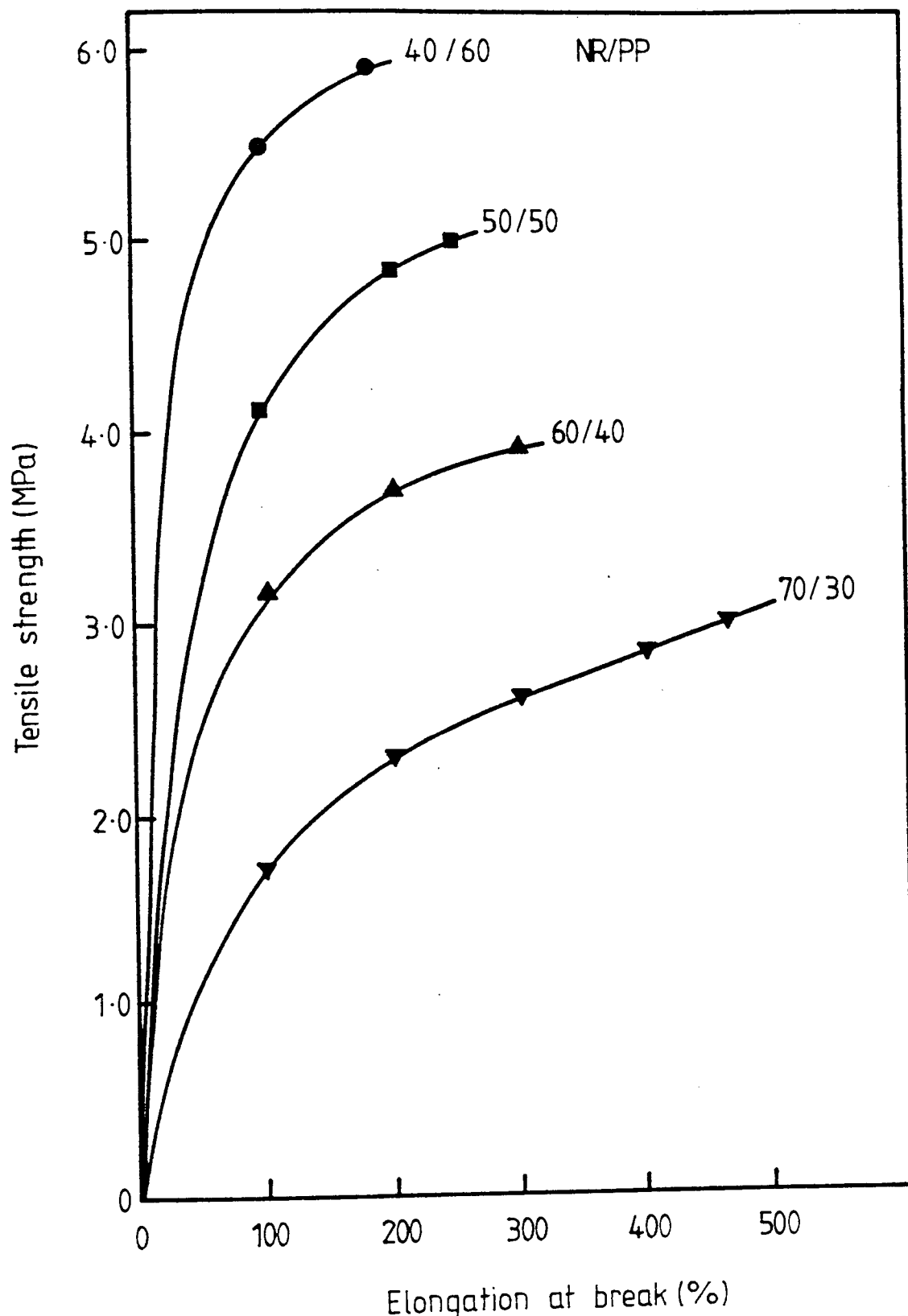

Figure 3.7 - Tensile strength vs. elongation at break of the NR/PP (60/40) blends processed at 160°C for 7 minutes in a Brabender Torque-rheometer.



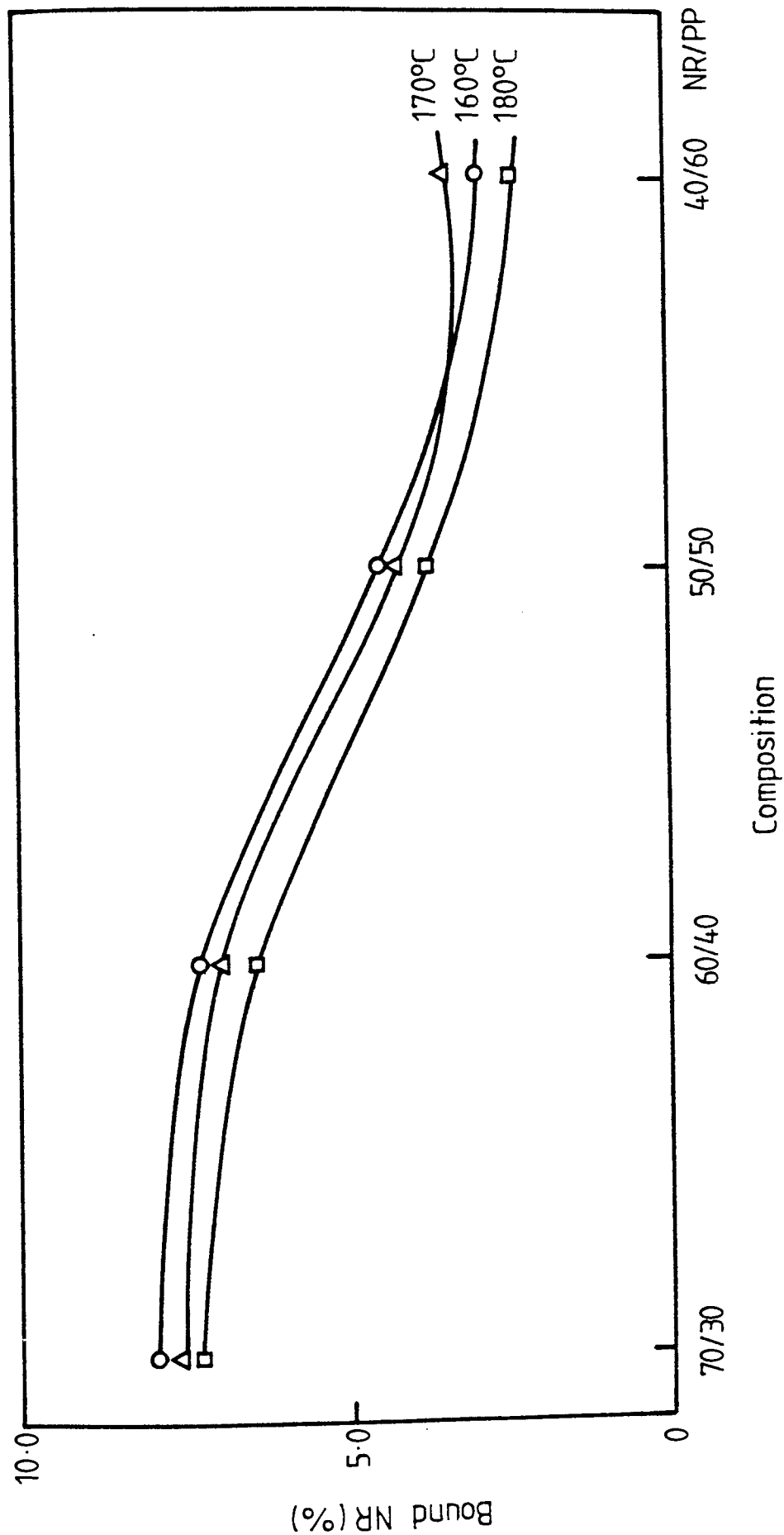

Figure 3.8 - Variation of the amount of bound natural rubber to polypropylene with the composition of blends processed for 5 minutes at different temperatures.

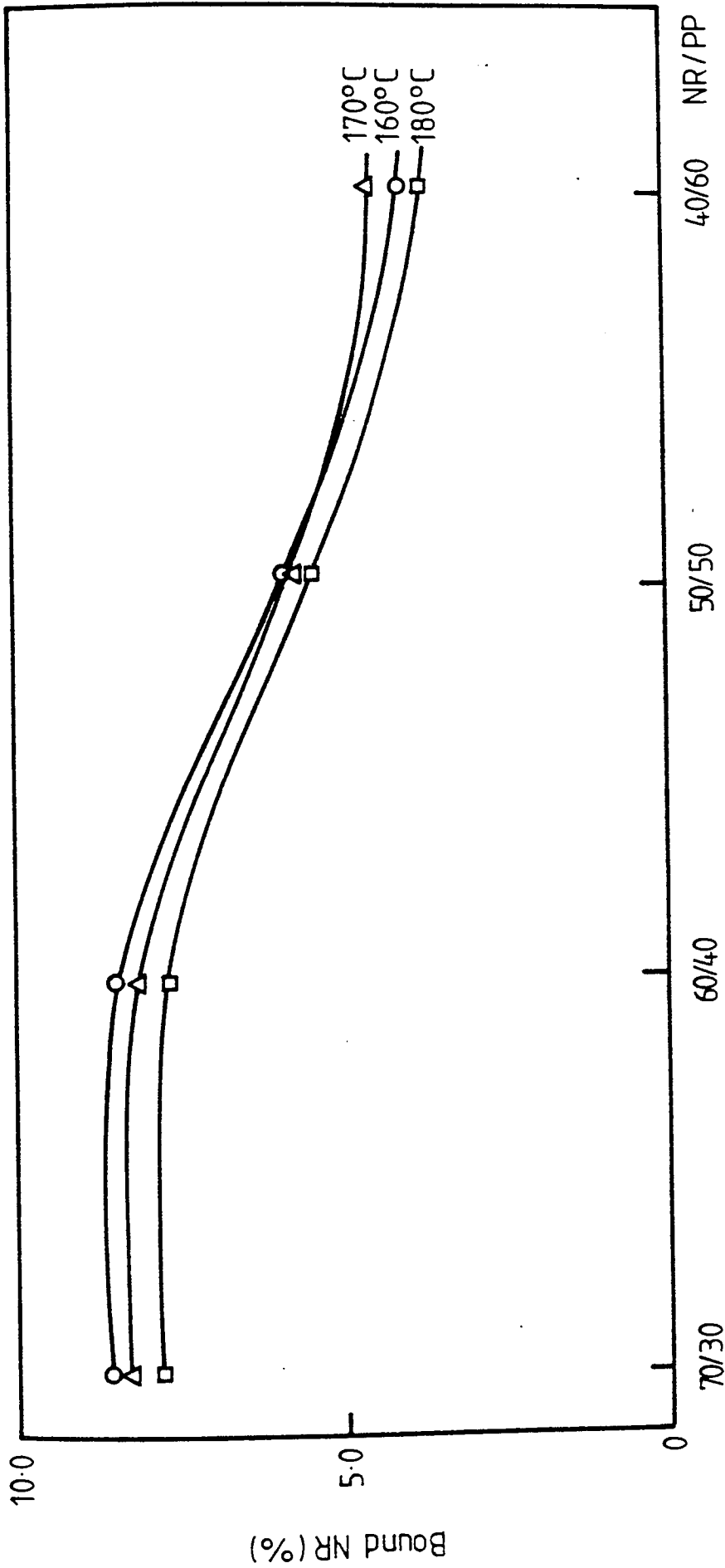

Figure 3.9 - Variation of the amount of binding of natural rubber to polypropylene with the composition of the blends processed for 7 minutes at different temperatures.

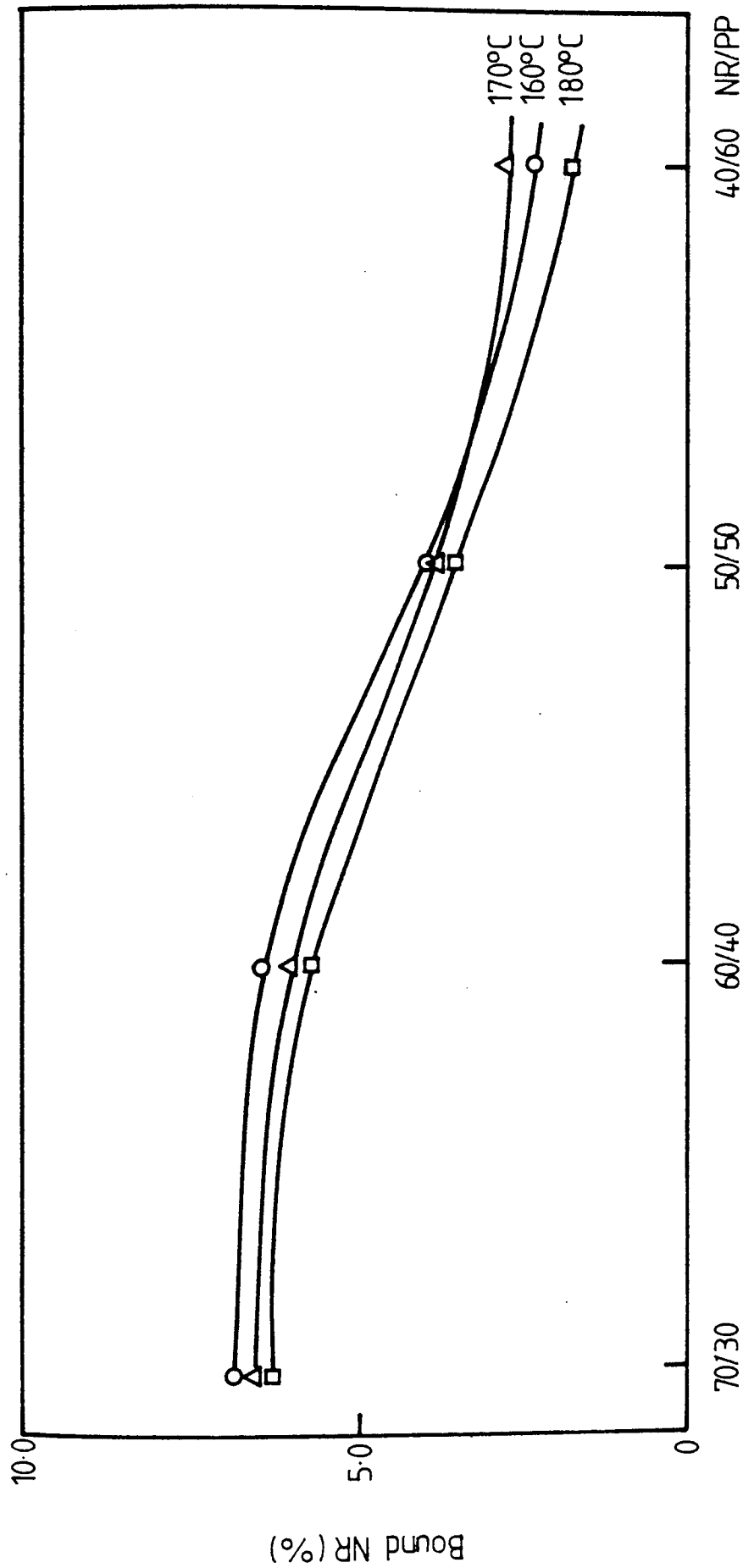

Figure 3.10 - Variation of the amount of binding of natural rubber to polypropylene with the composition of the blends processed for 9 minutes at different temperatures.

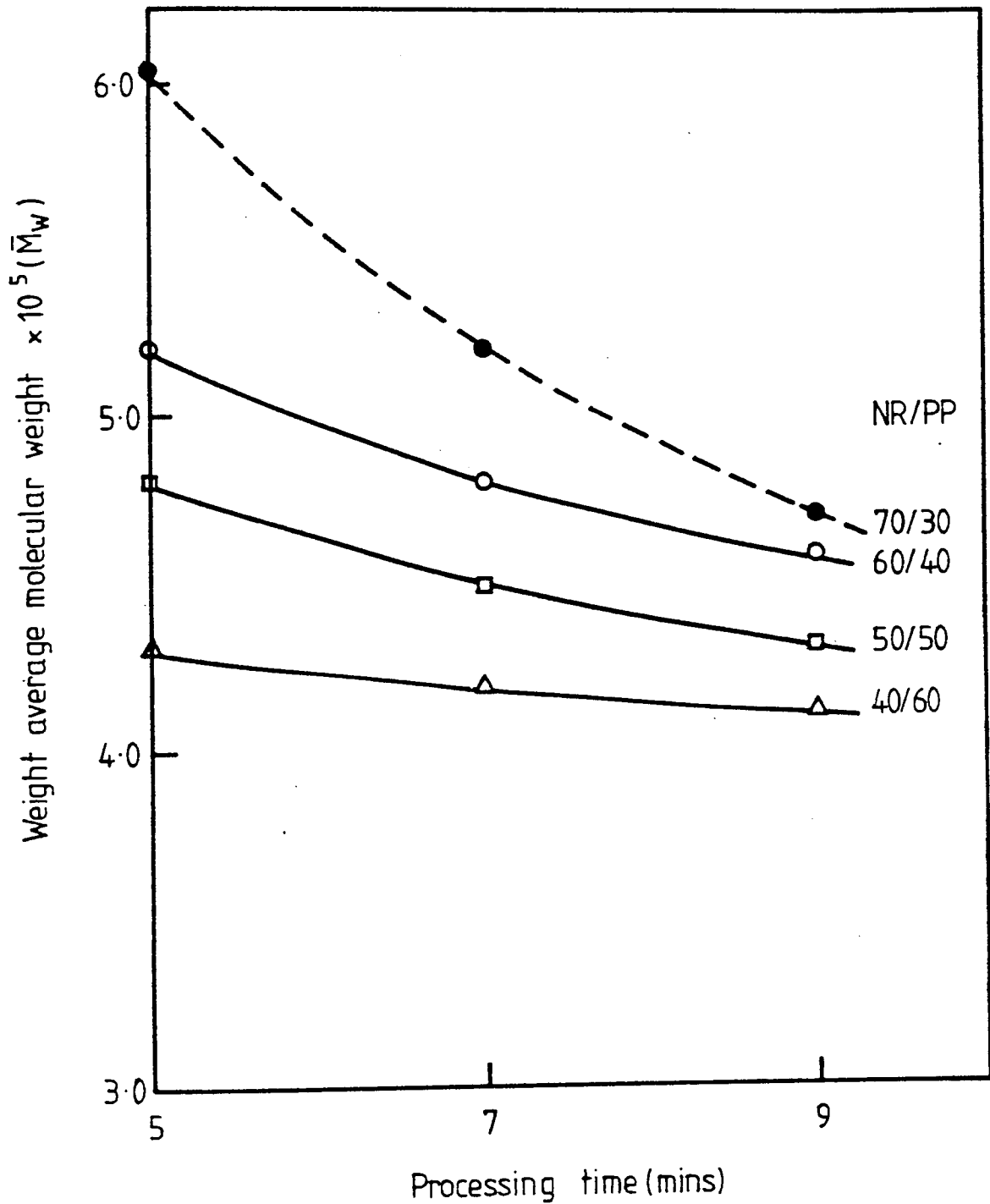

Figure 3.11 - Variation of weight average molecular weight ( $\bar{M}_w$ ) of the petroleum ether extracted NR/PP blends processed at 160°C for different processing times.

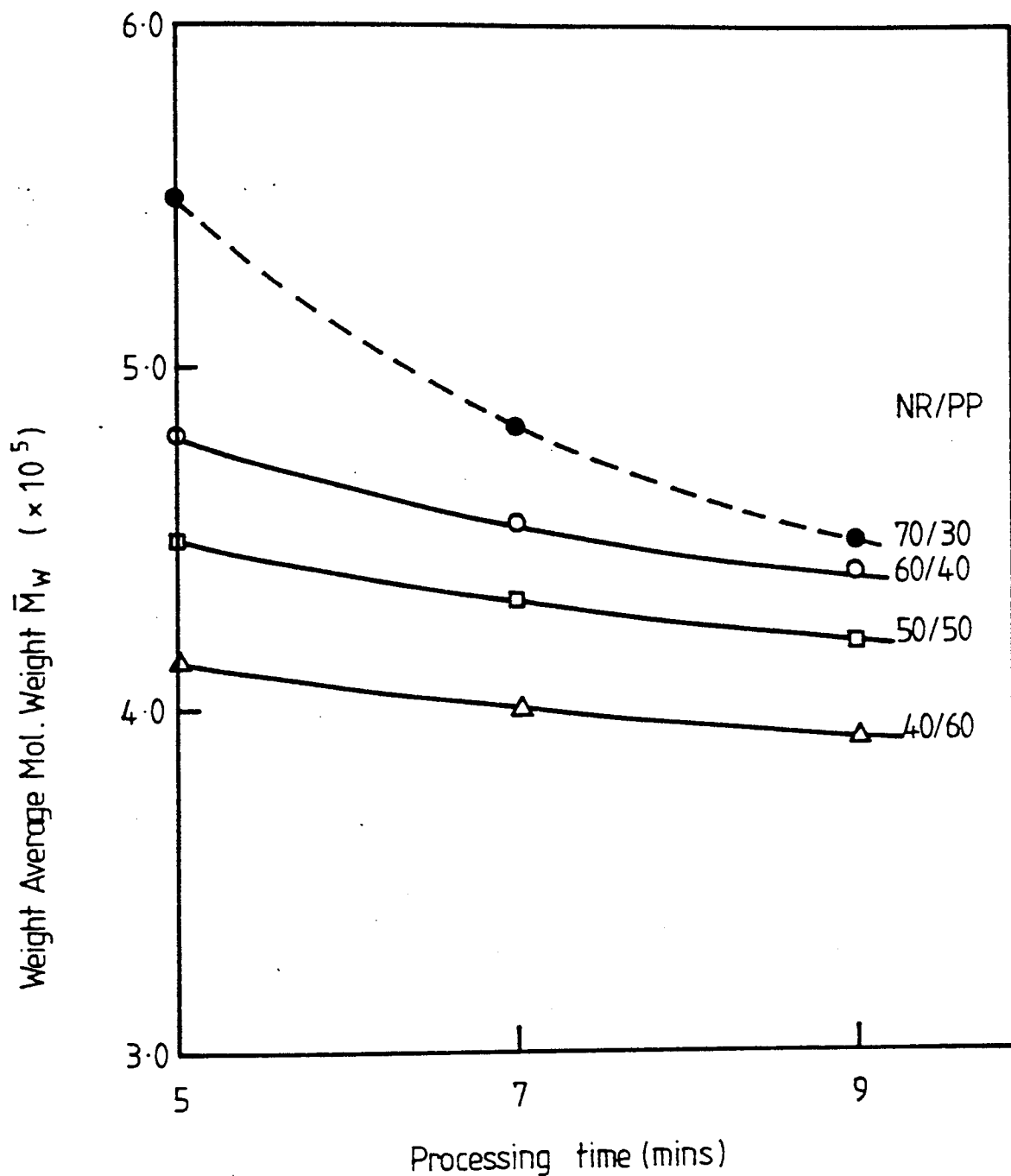

Figure 3.12 - Variation of weight average molecular weight ( $\bar{M}_w$ ) of blends processed at  $170^\circ\text{C}$  for different processing times.

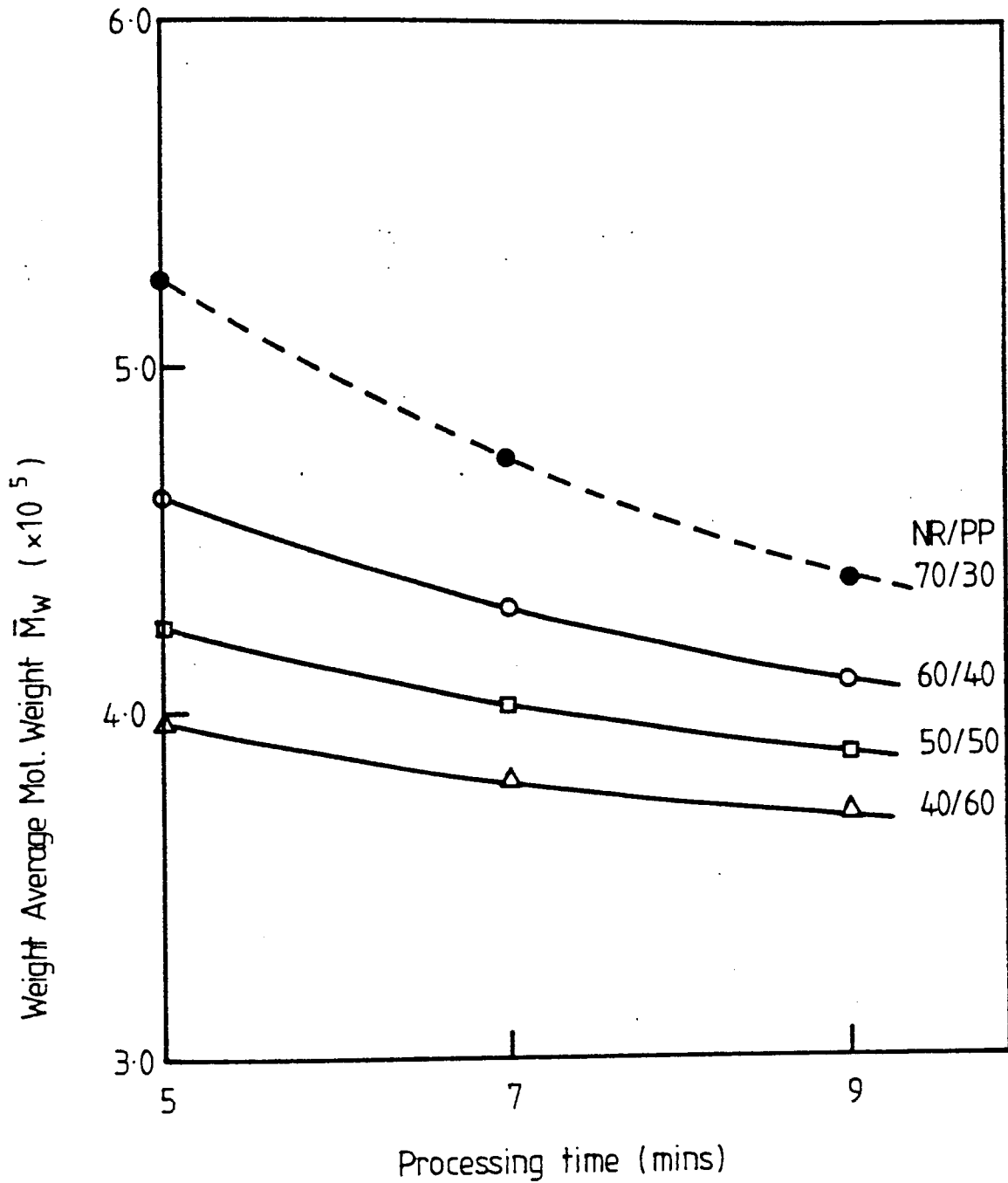

Figure 3.13 - Variation of weight average molecular weight of the petroleum ether extracted blends processed at  $180^\circ\text{C}$  for different processing times.

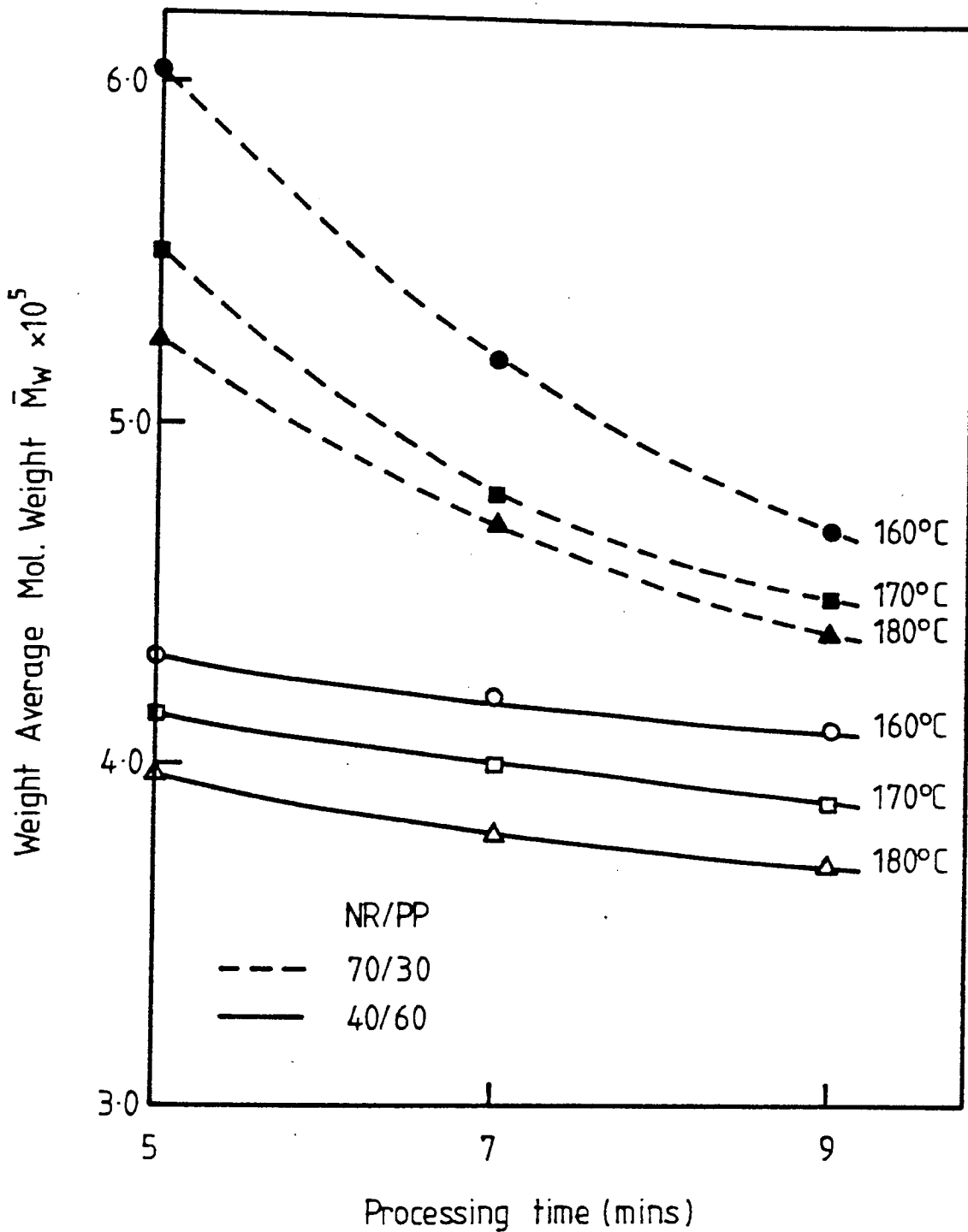
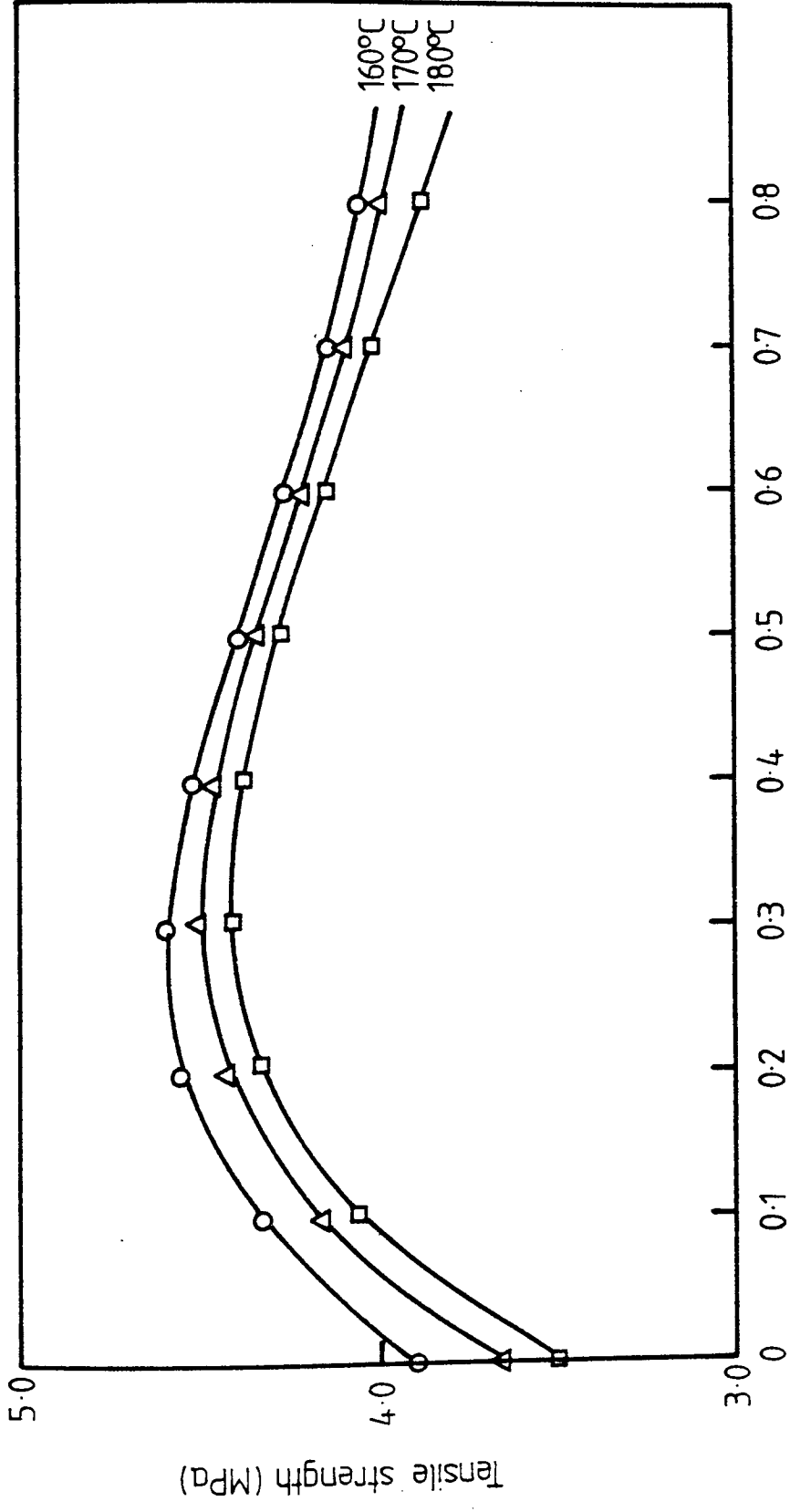

Figure 3.14 - Changes in weight average molecular weight ( $\bar{M}_w$ ) of two different blend compositions studied with processing times and temperatures.



**Benzoyl peroxide concentration (phr)**

**Figure 3.15 - Effect of benzoyl peroxide on the tensile strength of NR/PP (60/40) blends processed for 7 minutes in a Brabender Torque rheometer.**



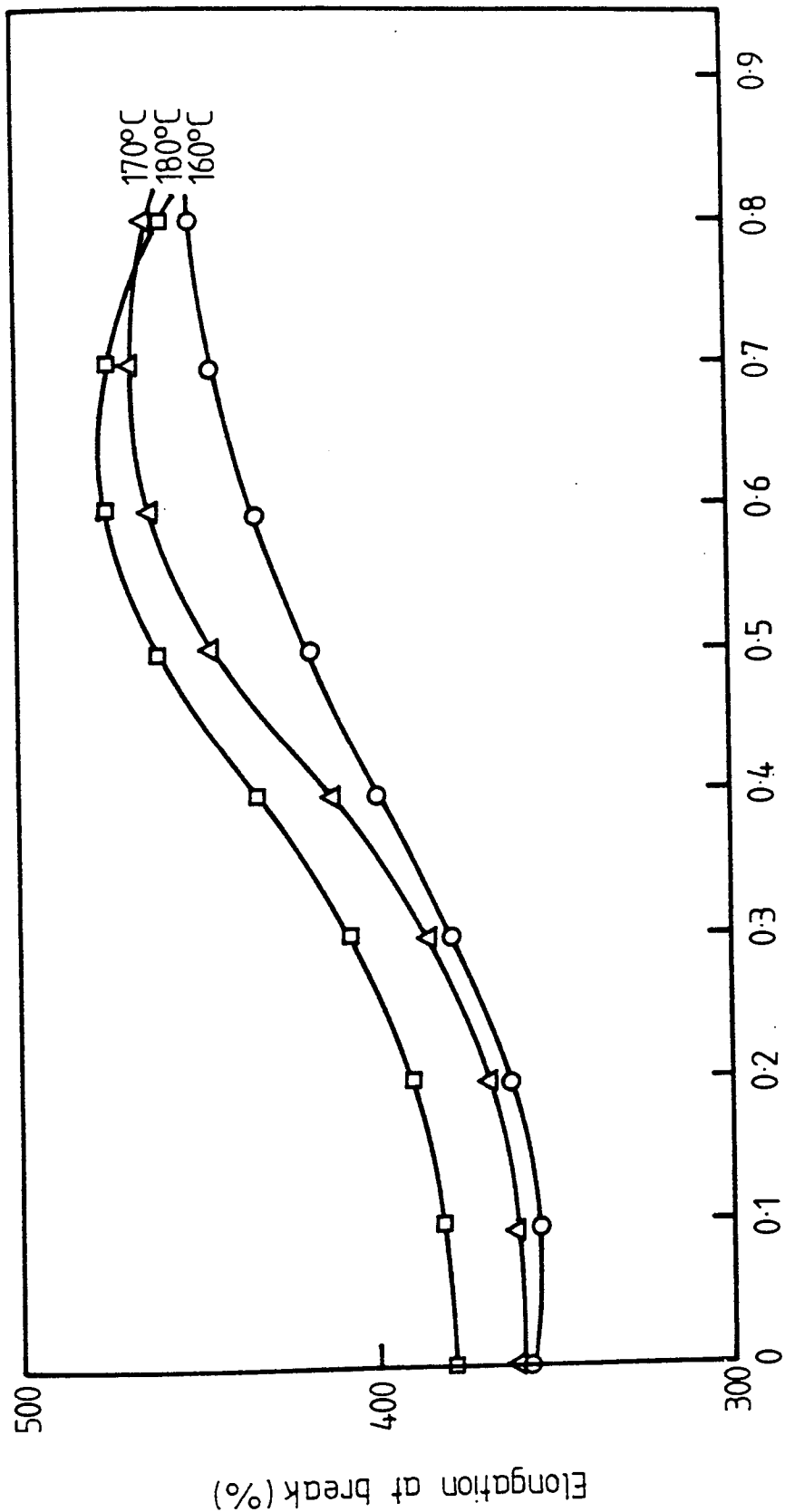

Benzoyl peroxide concentration (phr)

Figure 3.16 - Effect of benzoyl peroxide and processing temperatures on the elongation at break of NR/PP (60/40) blends processed for 7 minutes in a Brabender Torquerheometer.

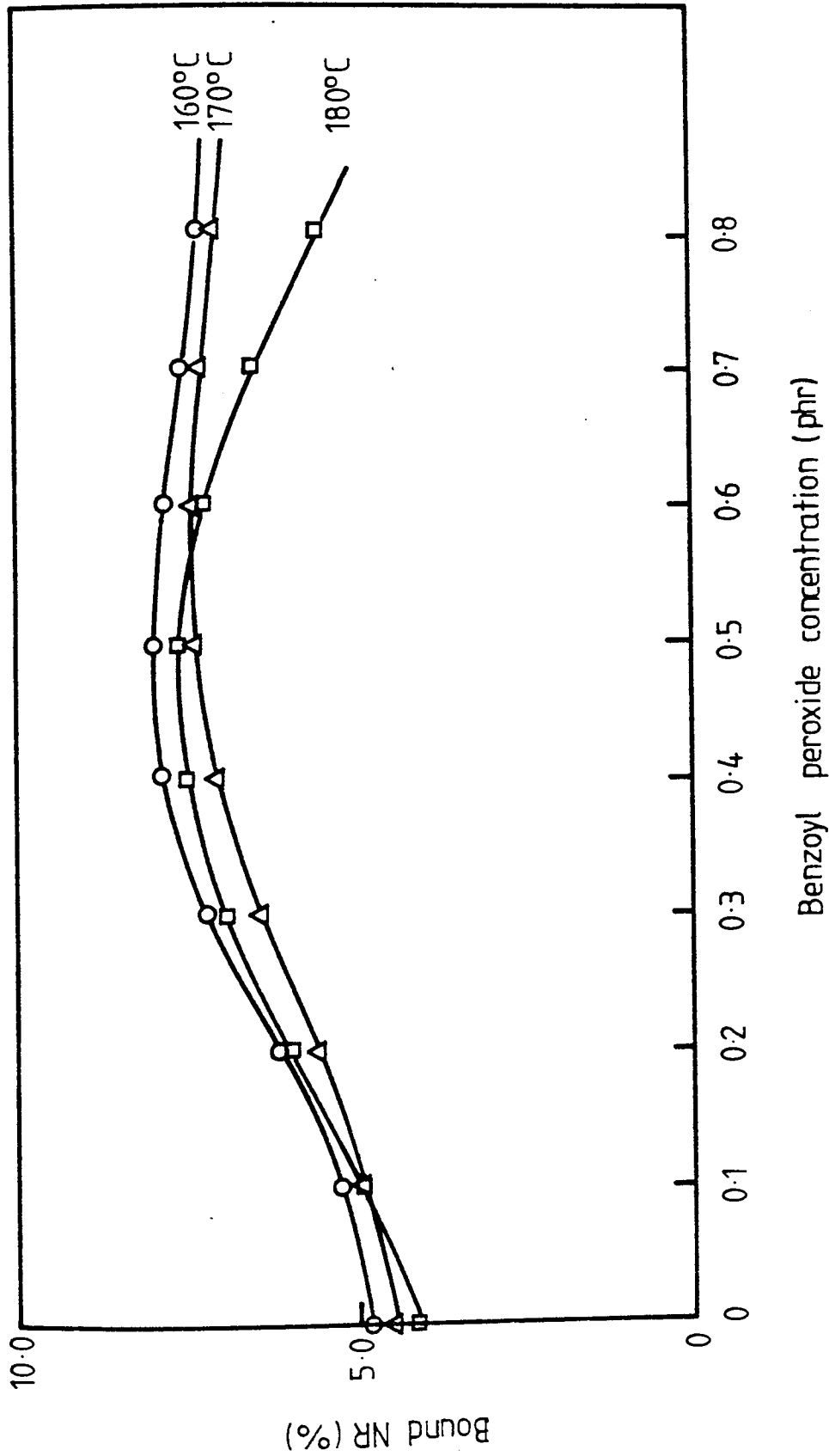

Figure 3.17 - The effect of benzoyl peroxide and processing times on the bounding of NR to polypropylene of NR/PP (60/40) blends processed for 7 minutes in a Brabender Torque rheometer.

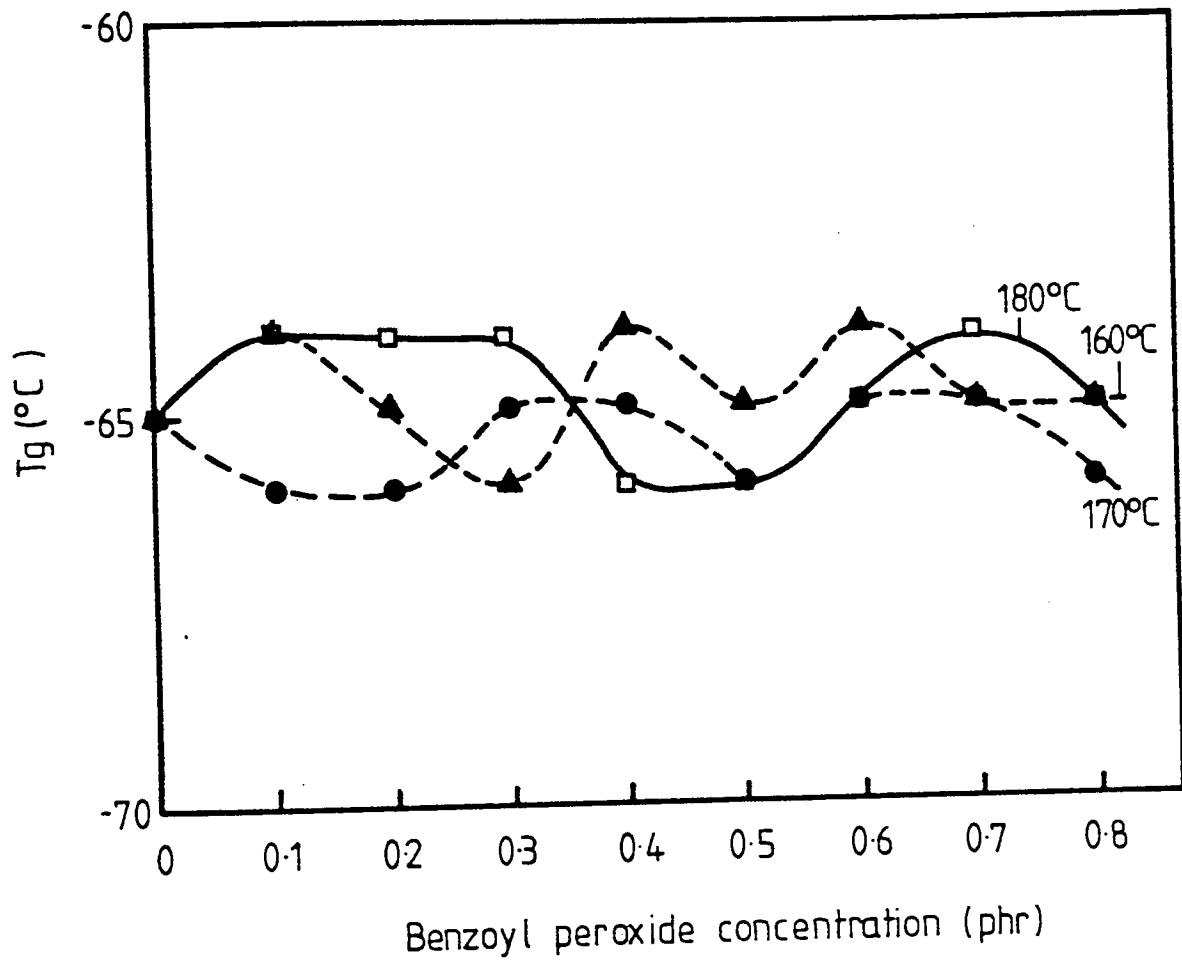

Figure 3.18 - The effect of benzoyl peroxide and processing temperatures on the glass transition temperatures ( $T_g$ ) of NR/PP (60/40) blends processed for 7 minutes in a Brabender Torquerheometer.

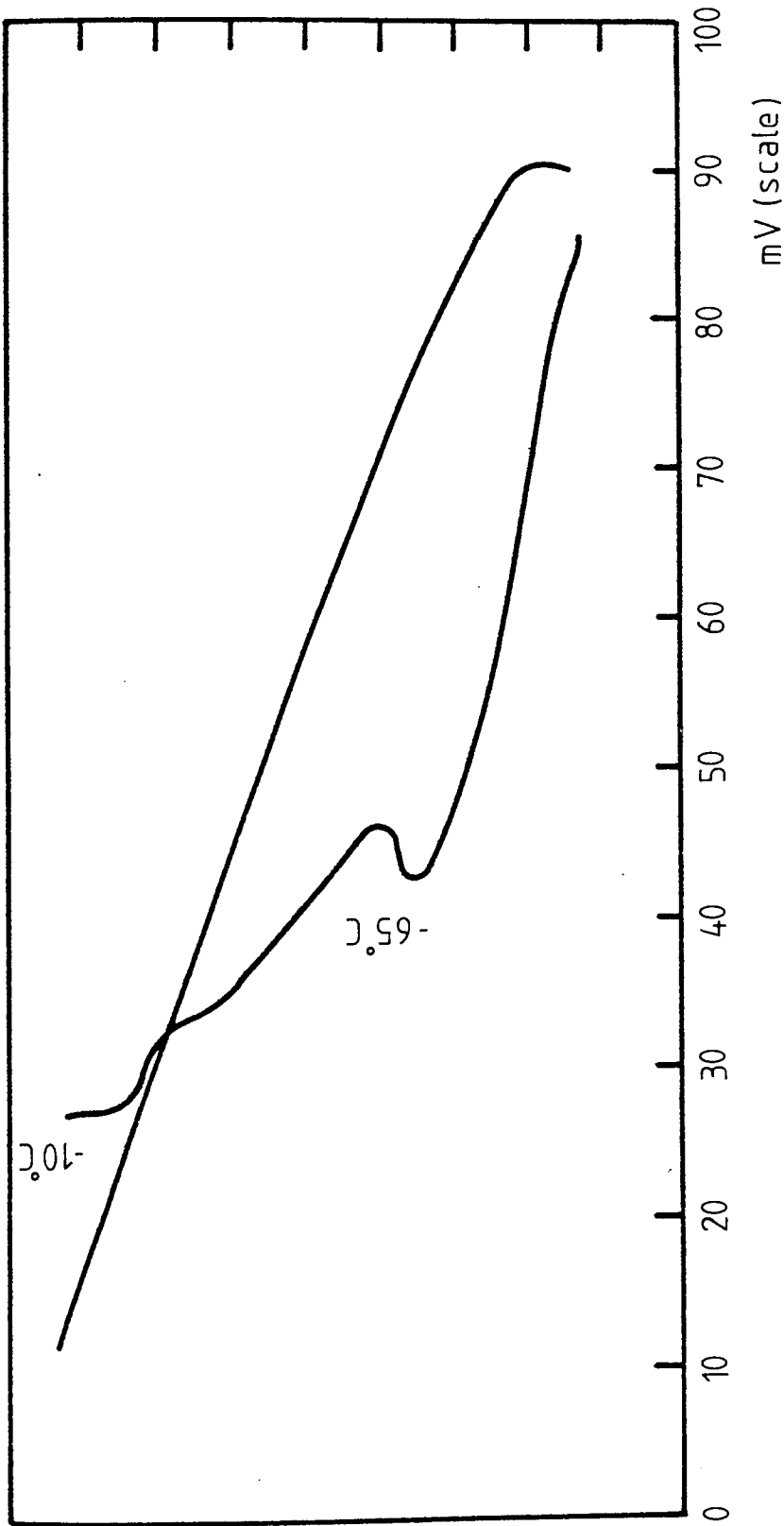

Figure 3.19 A typical Differential Thermal Analysis (DTA) showing the Tg of natural rubber at ( -65°C) and polypropylene at ( -10°C) in NR/PP (60/40) blend.

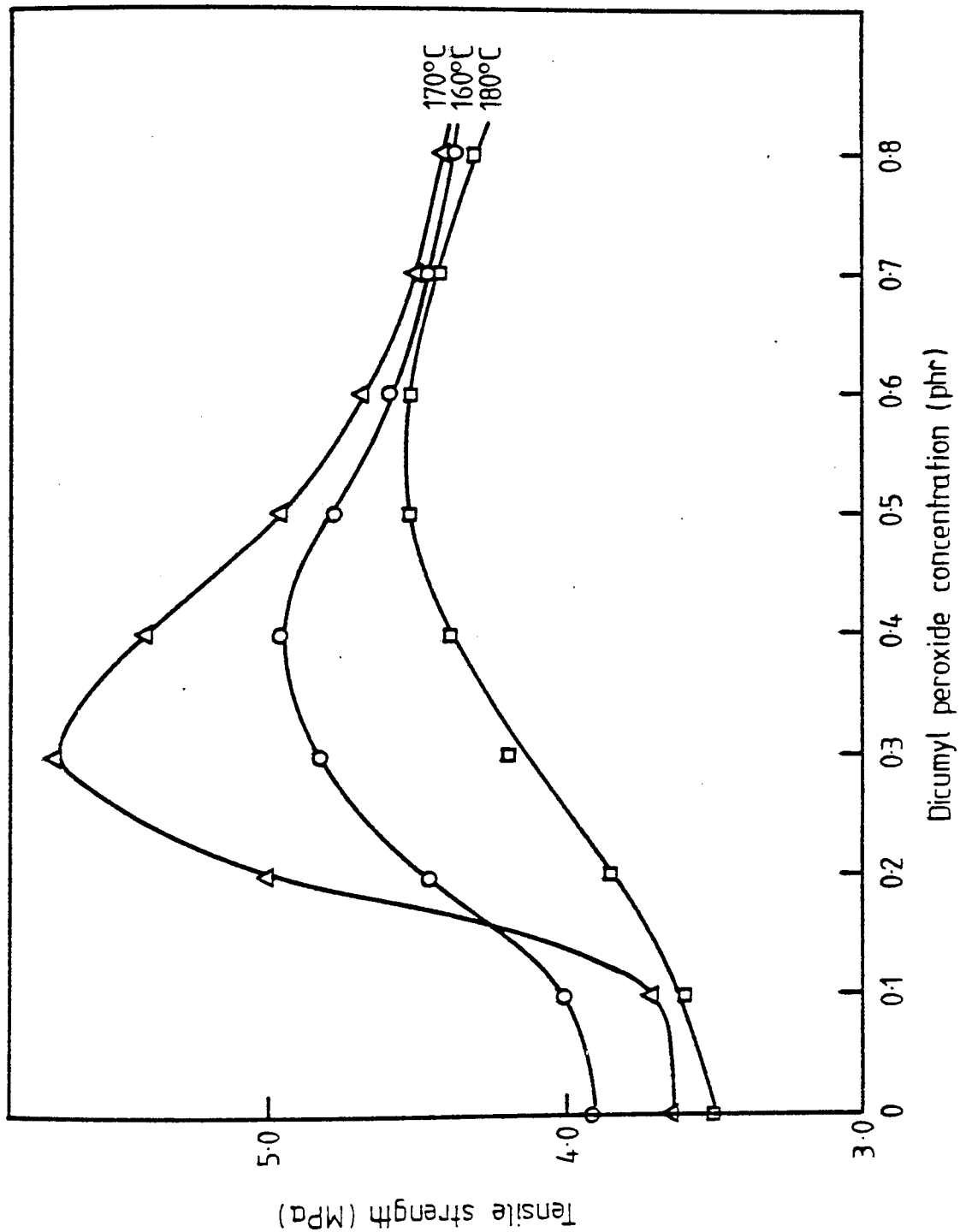

Figure 3.20 - Effect of dicumyl peroxide and processing temperatures on the tensile strength of NR/PP (60/40) blends processed in a Brabender Torque rheometer for 7 minutes.

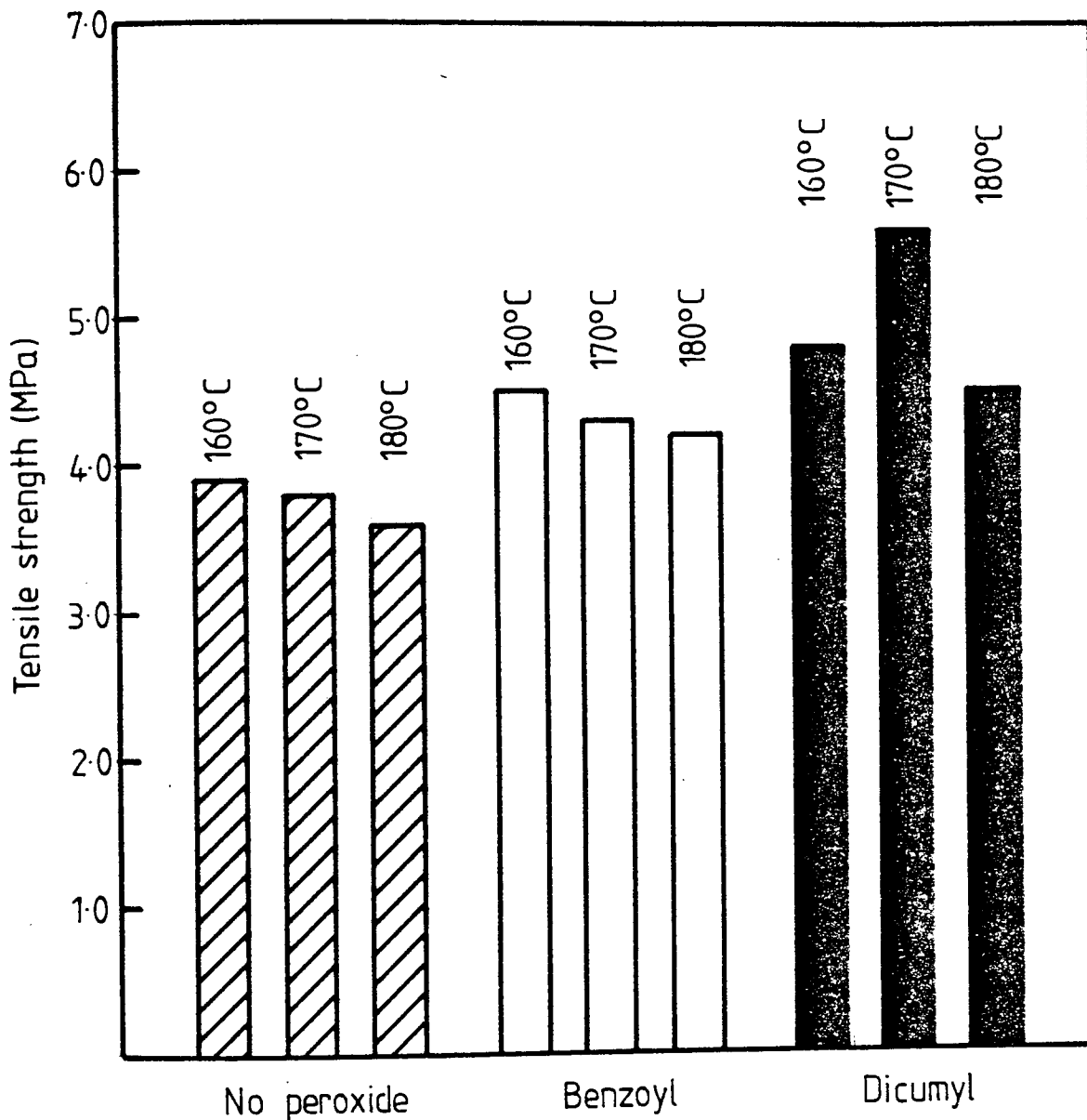

Figure 3.21 - Comparison in the maximum tensile strength of blends in the absence and presence of peroxide processed at different temperature (ratio 60/40 NR/PP, processing time 7 minutes, Method A).

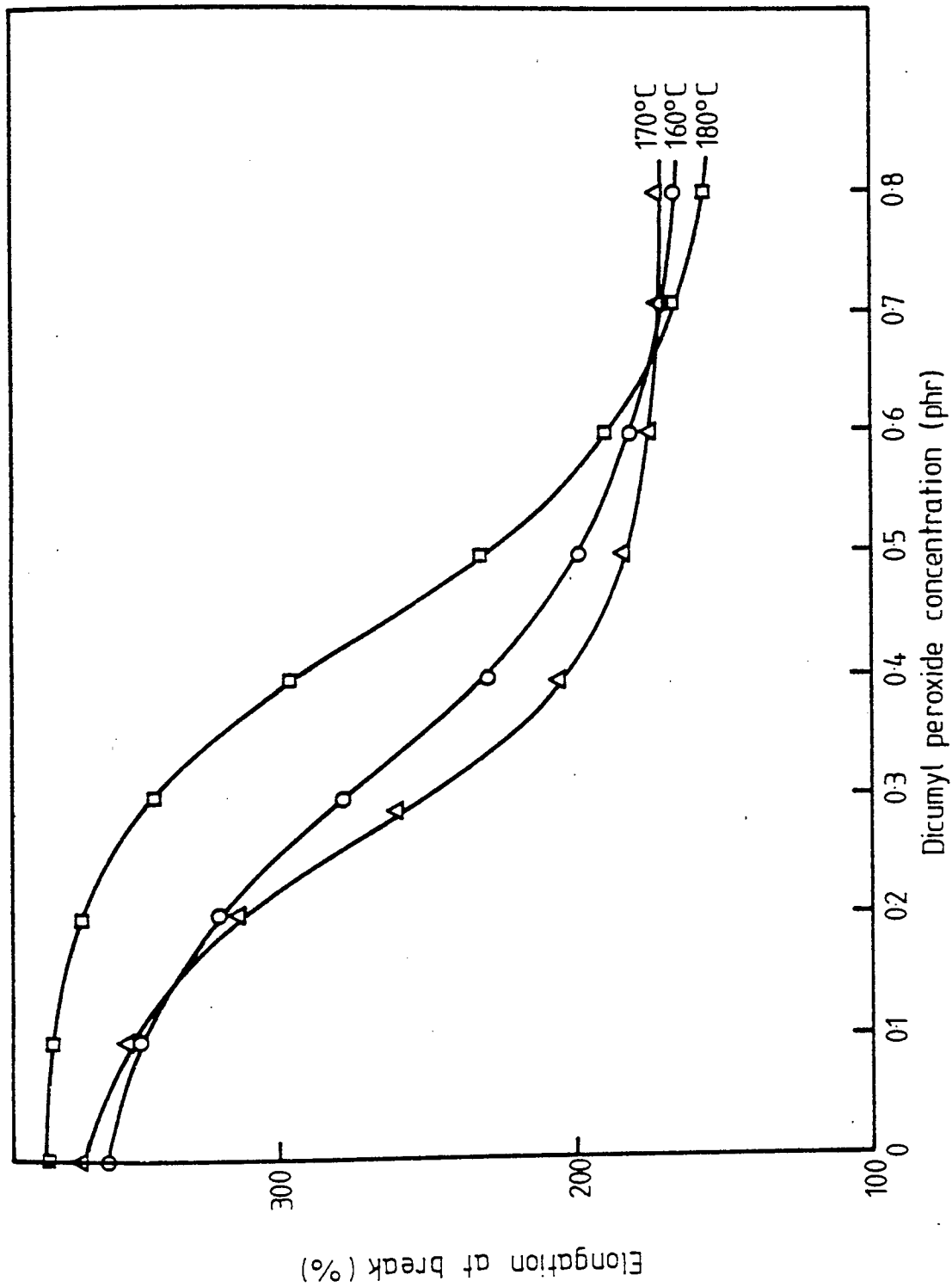
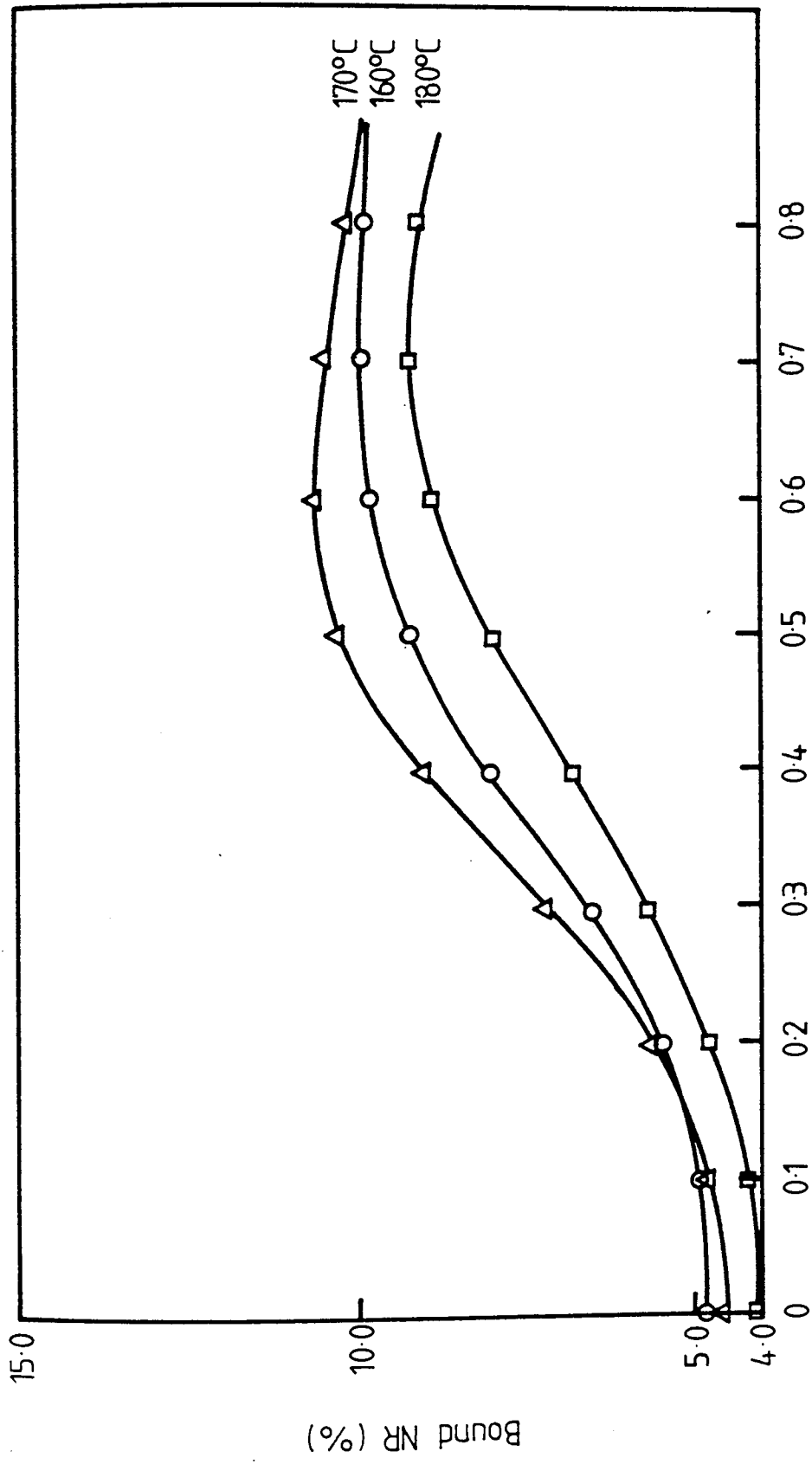

Figure 3.22 - Effect of dicumyl peroxide and processing temperatures on the elongation at break of NR/PP (60/40) blends processed in a Brabender Torquerheometer for 7 minutes.



Dicumyl peroxide concentration (phr)

Figure 3.23 - The effect of dicumyl peroxide and processing temperatures on the binding of natural rubber to polypropylene of NR/PP (60/40) blends processed for 7 minutes in a Brabender Torquerheometer.



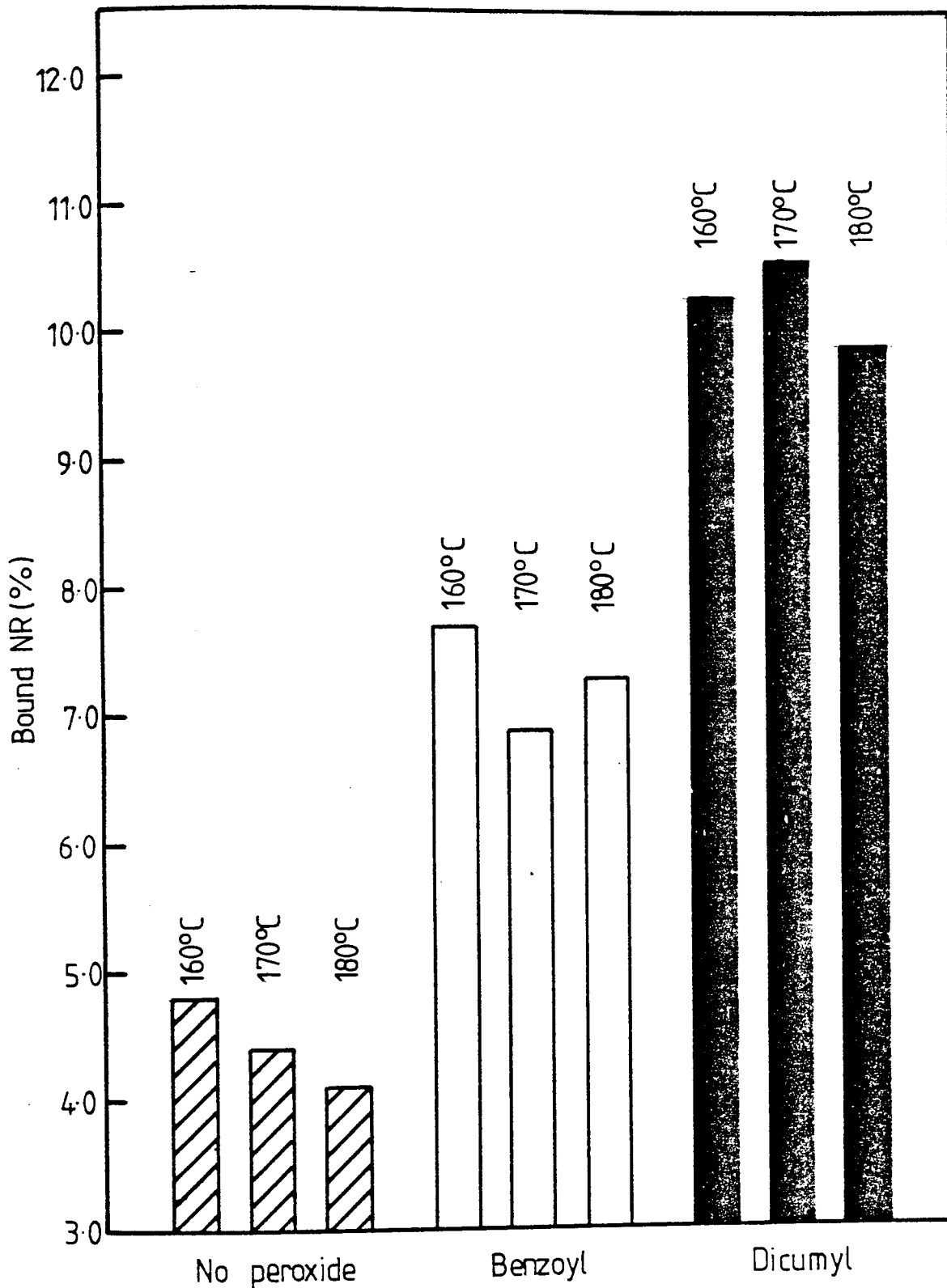

Figure 3.24 - Maximum binding of natural rubber to polypropylene in the absence and presence of peroxides (NR/PP 60/40 processing time at 7 minutes, Method A).

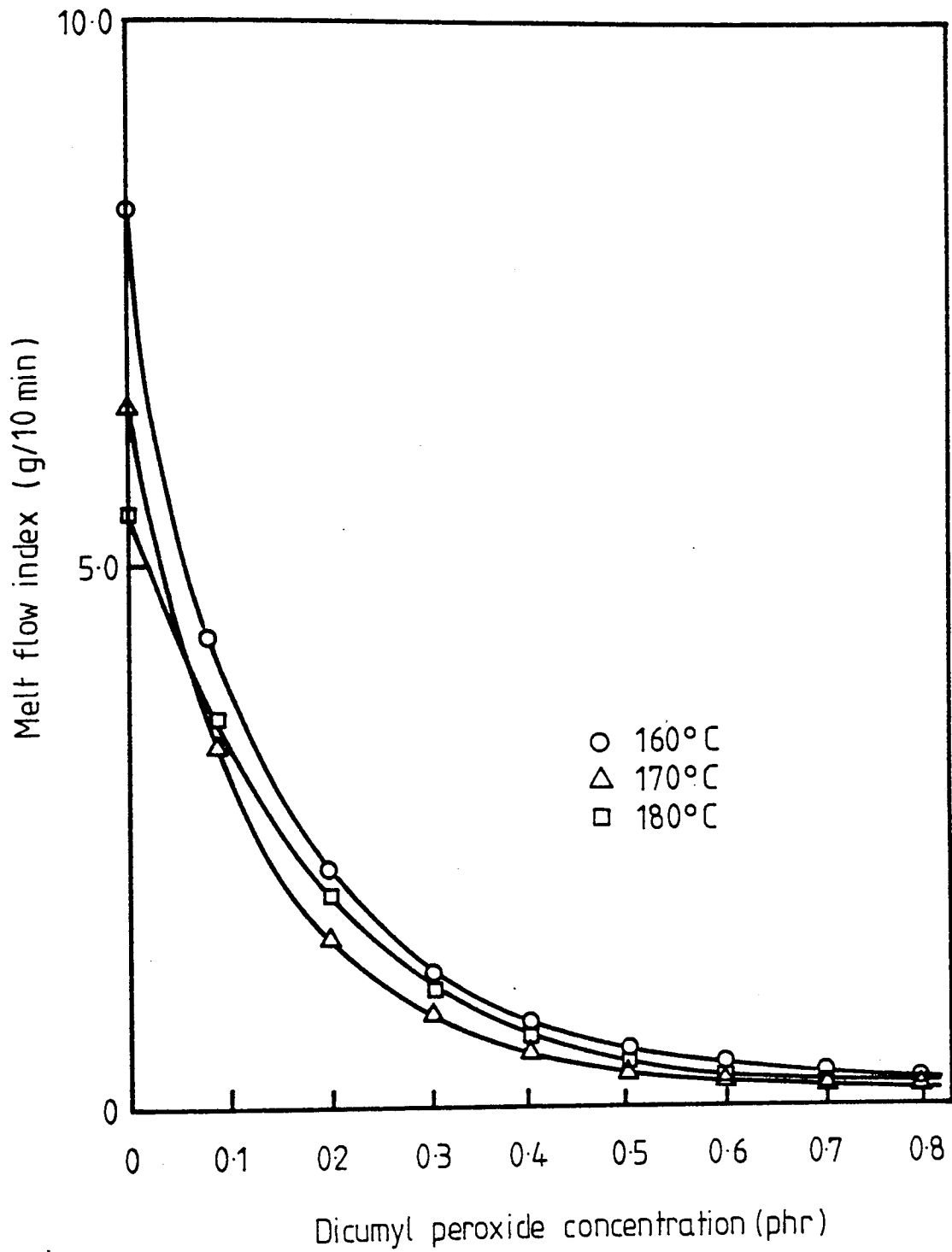

Figure 3.25 - The effect of dicumyl peroxide and processing temperatures on the melt flow index of NR/PP (60/40) blends processed for 7 minutes in a Brabender Torquerheometer.

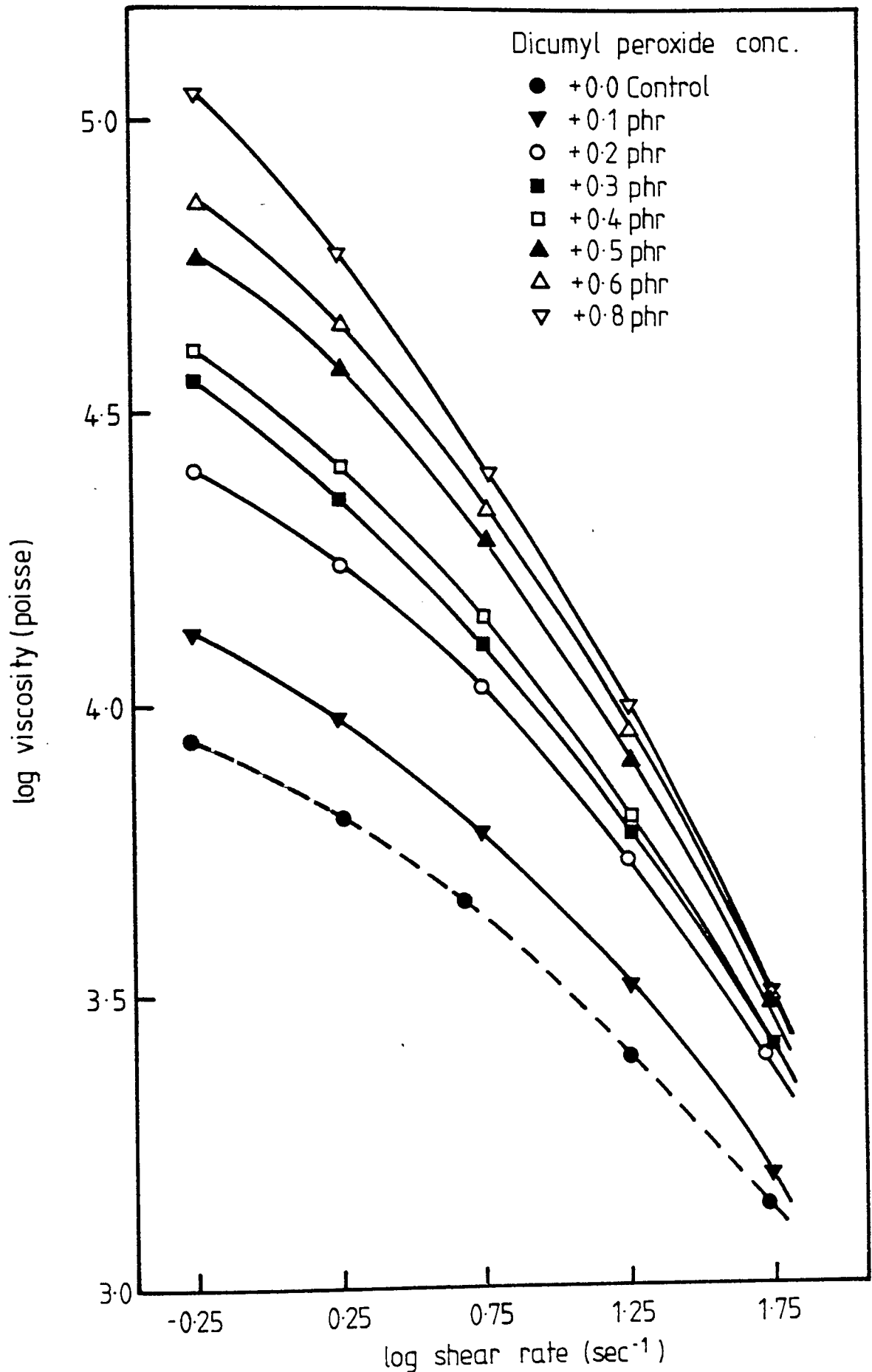

Figure 3.26 - The effect of dicumyl peroxide on the melt rheology of NR/PP (60/40) blends processed at 160°C for 7 minutes.

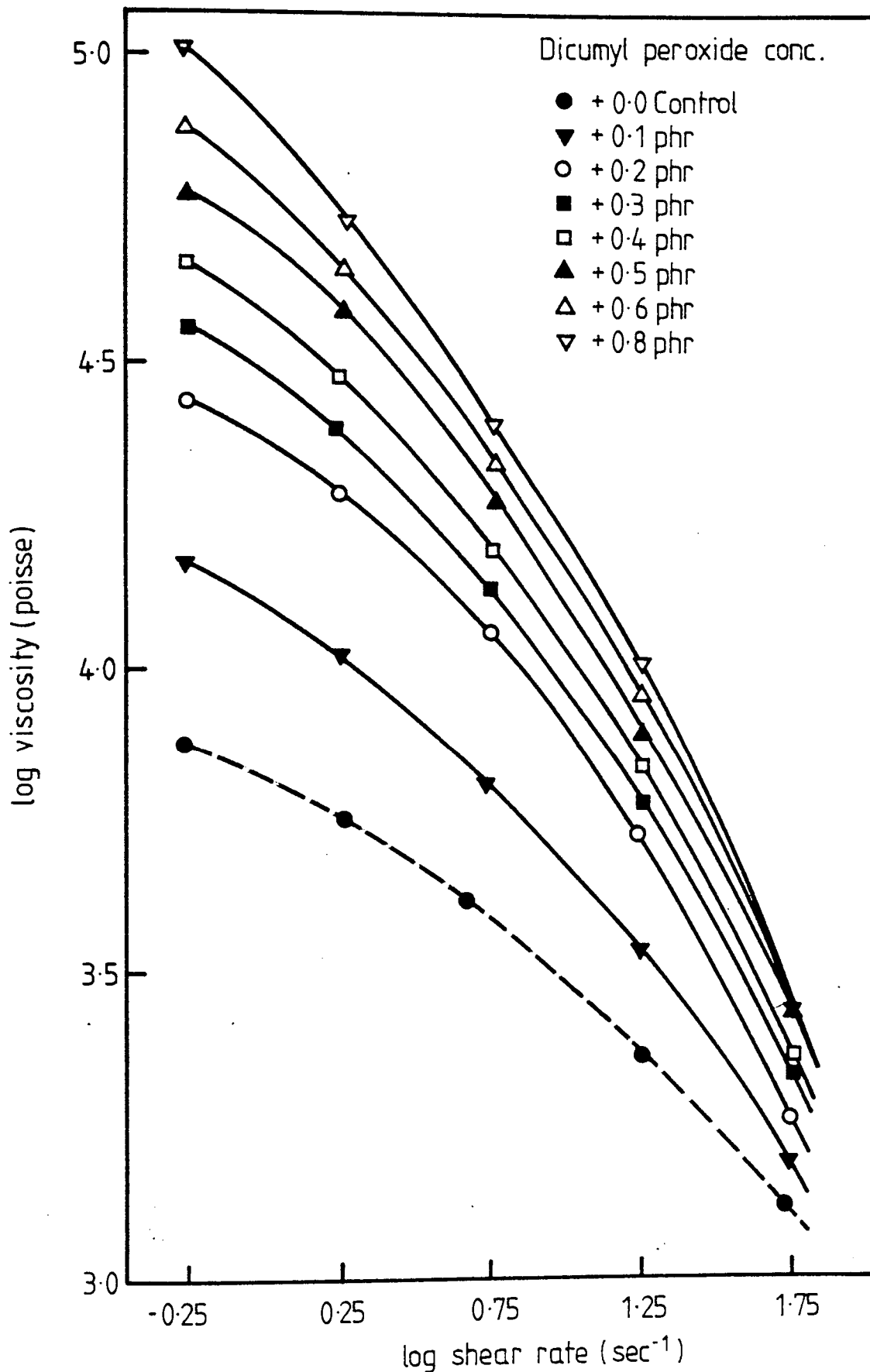

Figure 3.27 - The effect of dicumyl peroxide on the melt rheology of NR/PP (60/40) blends processed at 170°C for 7 minutes.

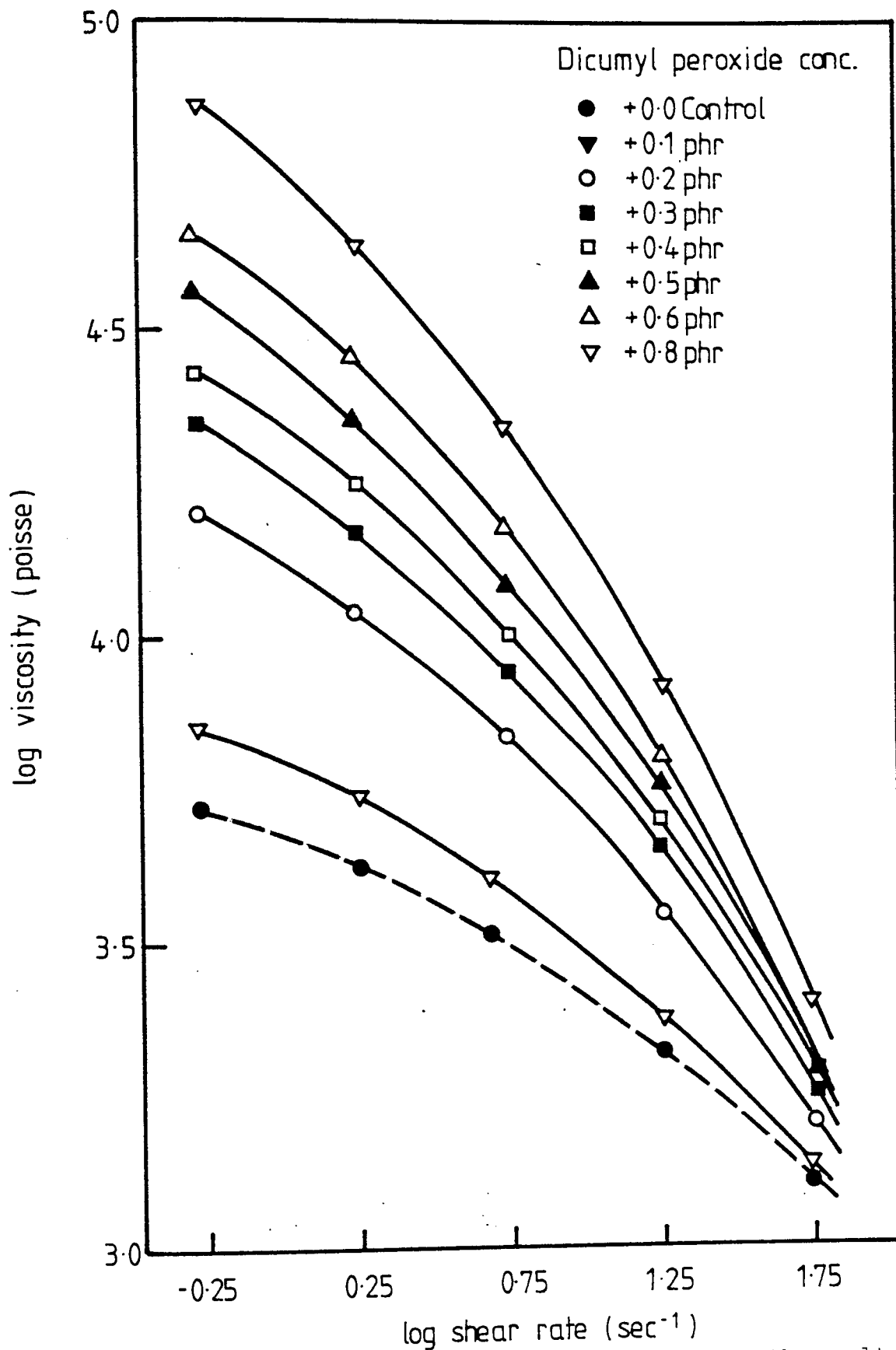

Figure 3.28 - The effect of dicumyl peroxide on the melt rheology of NR/PP (60/40) blends processed at 180°C for 7 minutes.

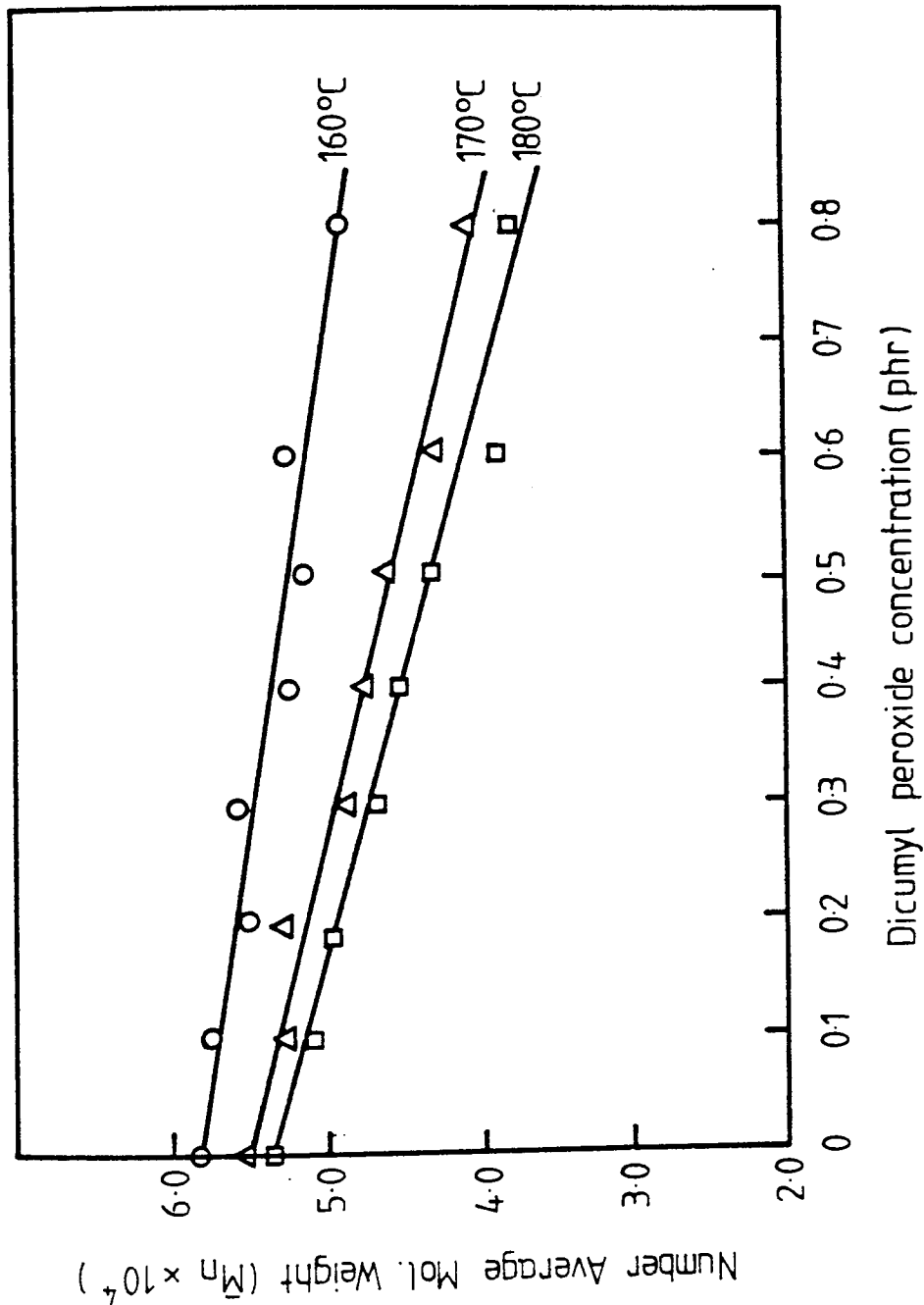

Figure 3.29 - The effect of dicumyl peroxide and processing temperatures on the ( $\bar{M}_n$ ) (Number Average  $\bar{M}_w$ ) of NR/PP (60/40) blends processed for 7 minutes in a Brabender Torque rheometer.

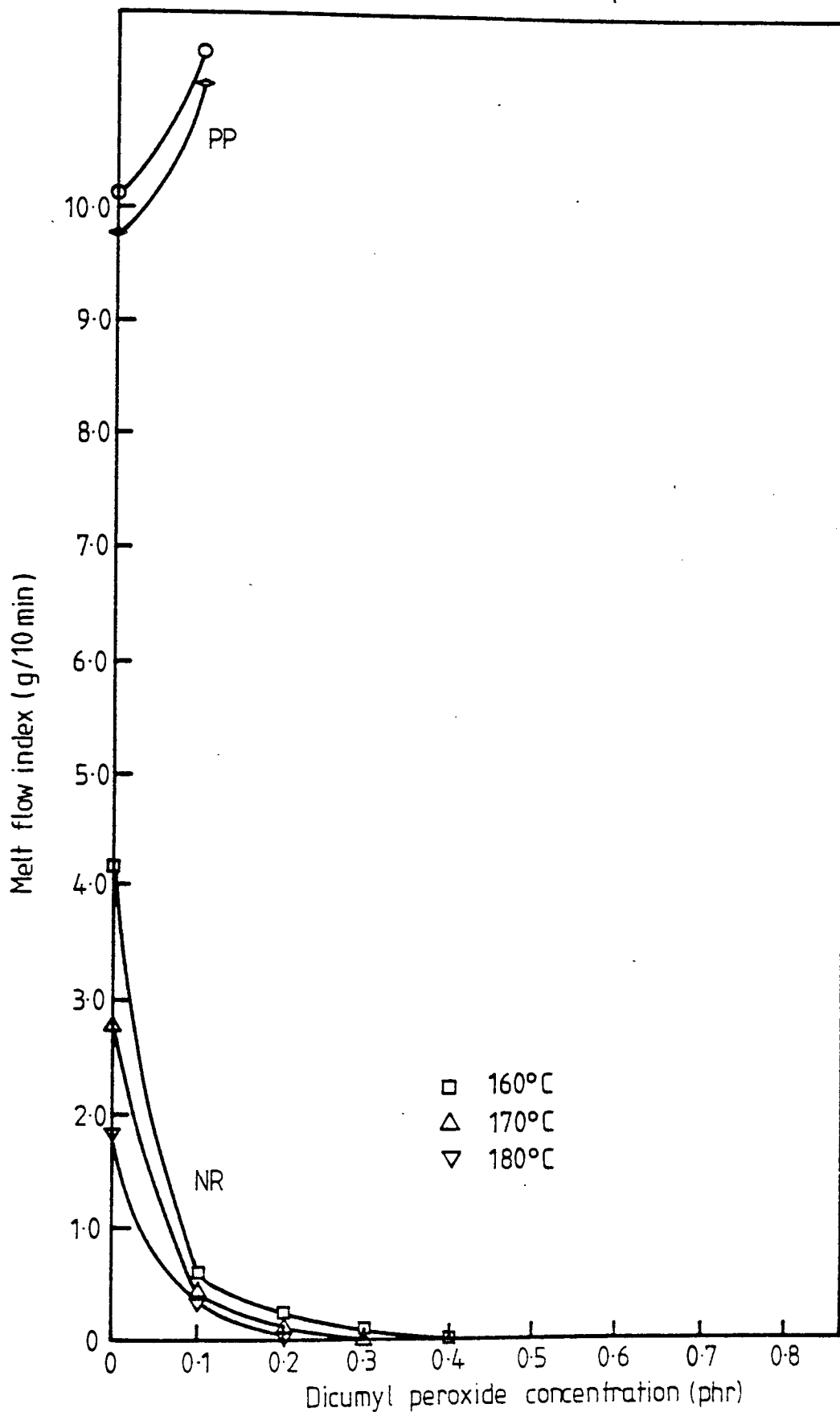

Figure 3.30 - Effect of dicumyl peroxide on the melt flow index of NR and PP processed separately in a Brabender Torquerheometer at 160°C for 7 minutes.

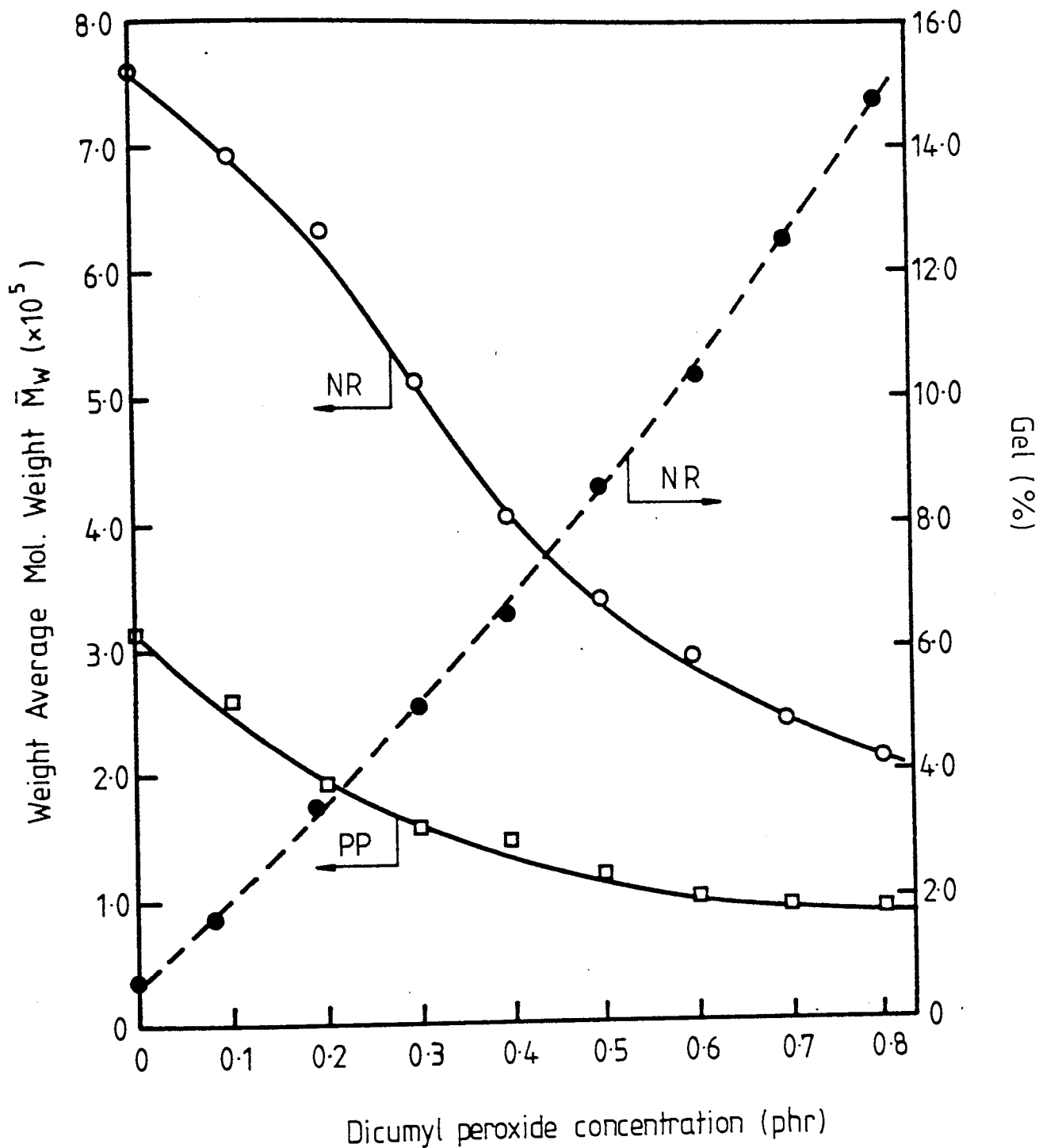

Figure 3.31 - The effect of dicumyl peroxide on the weight average molecular weight of natural rubber and polypropylene processed in a Brabender Torquerheometer separately at  $160^{\circ}\text{C}$  for 7 minutes (materials were gel-free).



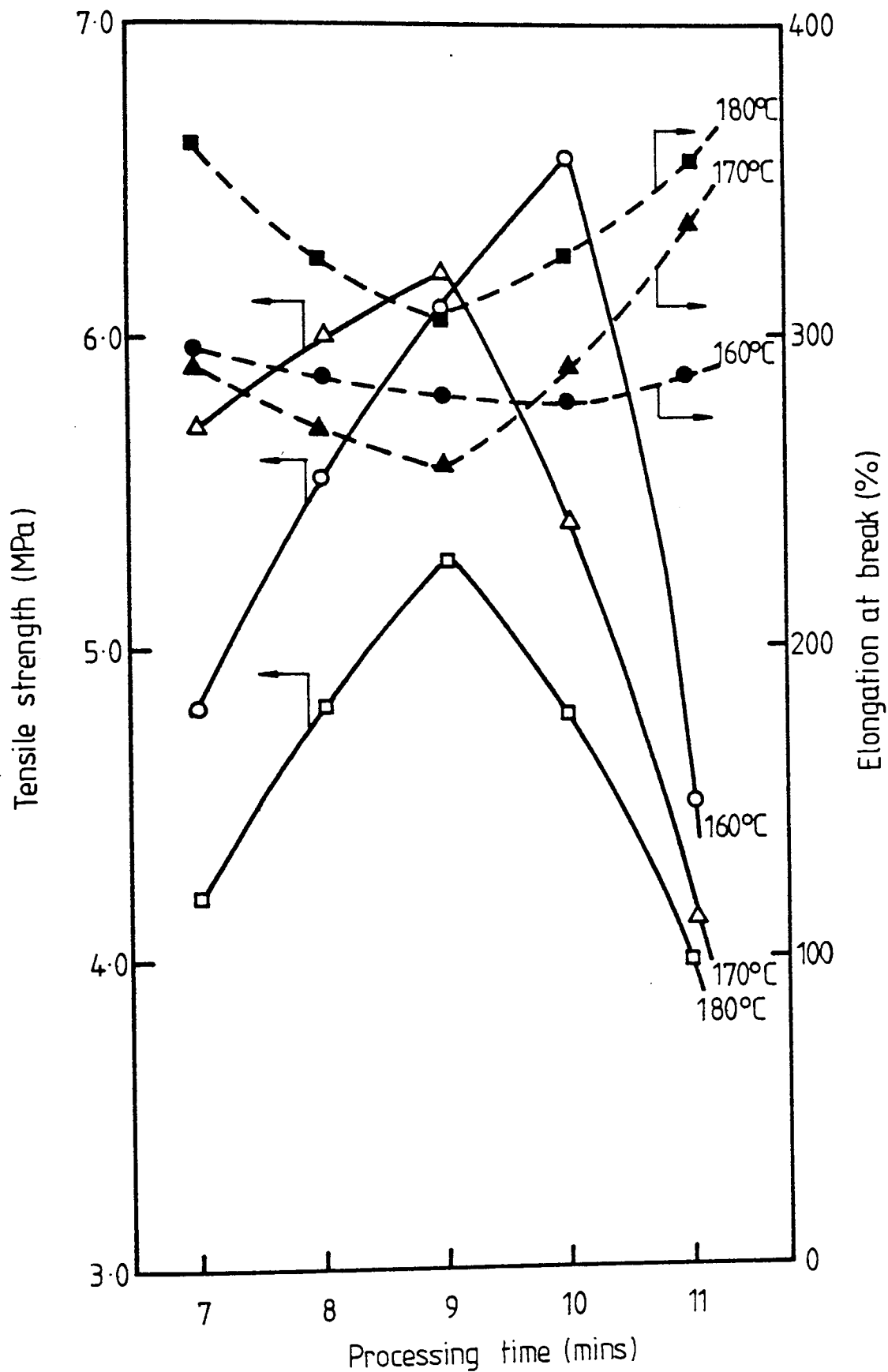

Figure 3.32 - The effect of varying processing times and temperatures on the tensile properties of NR/PP (60/40) blends containing 0.3 phr. dicumyl peroxide.

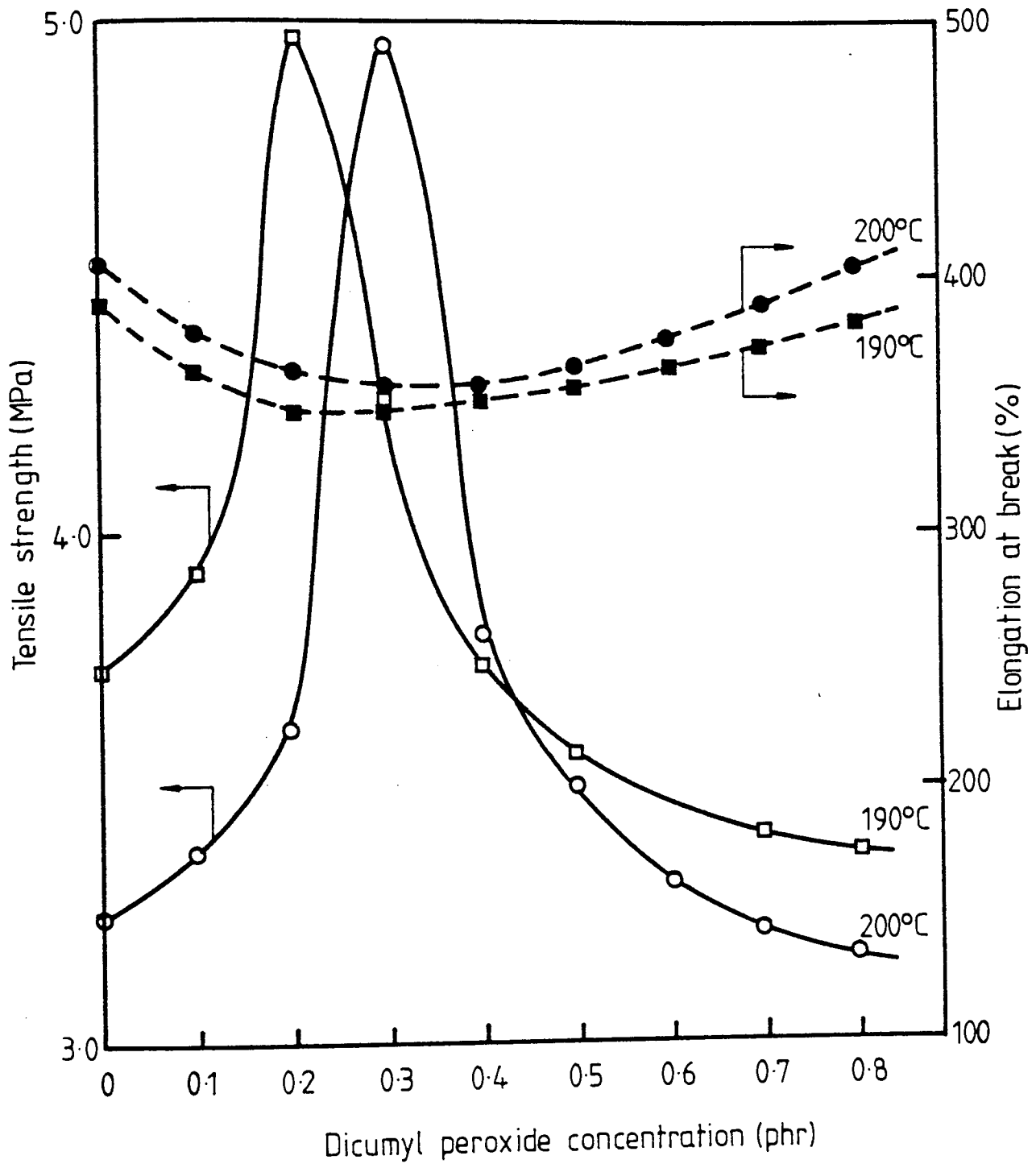

Figure 3.33 - The effect of varying concentration of dicumyl peroxide on the tensile properties of NR/PP (60/40) blends processed at high temperatures (antioxidant Nonox WSP 1 phr.)

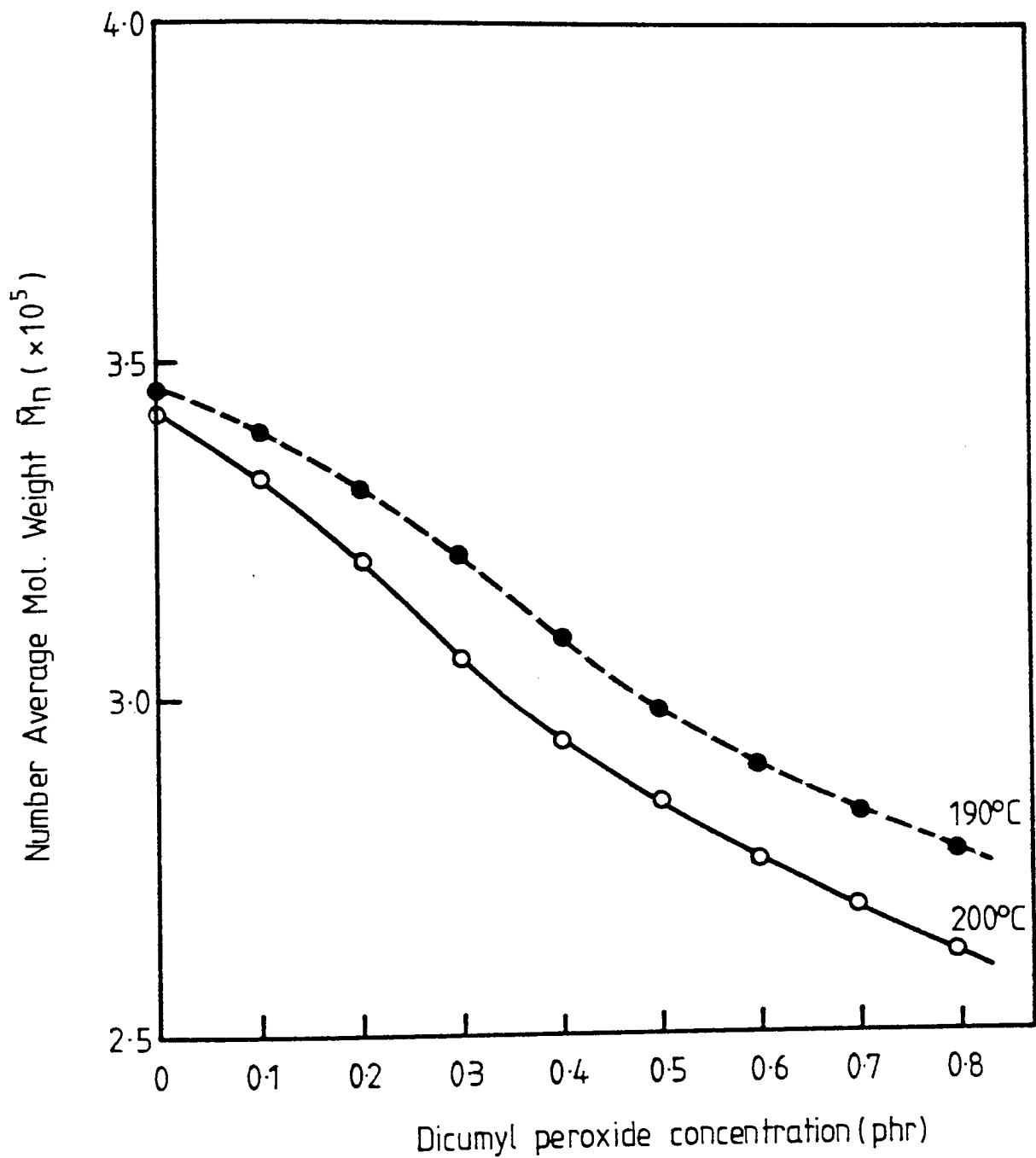

Figure 3.34 - The effect of varying concentration of dicumyl peroxide on the  $\bar{M}_w$  of NR/PP (60/40) blends processed at high temperatures (antioxidant Nonox WSP 1.0 phr.)

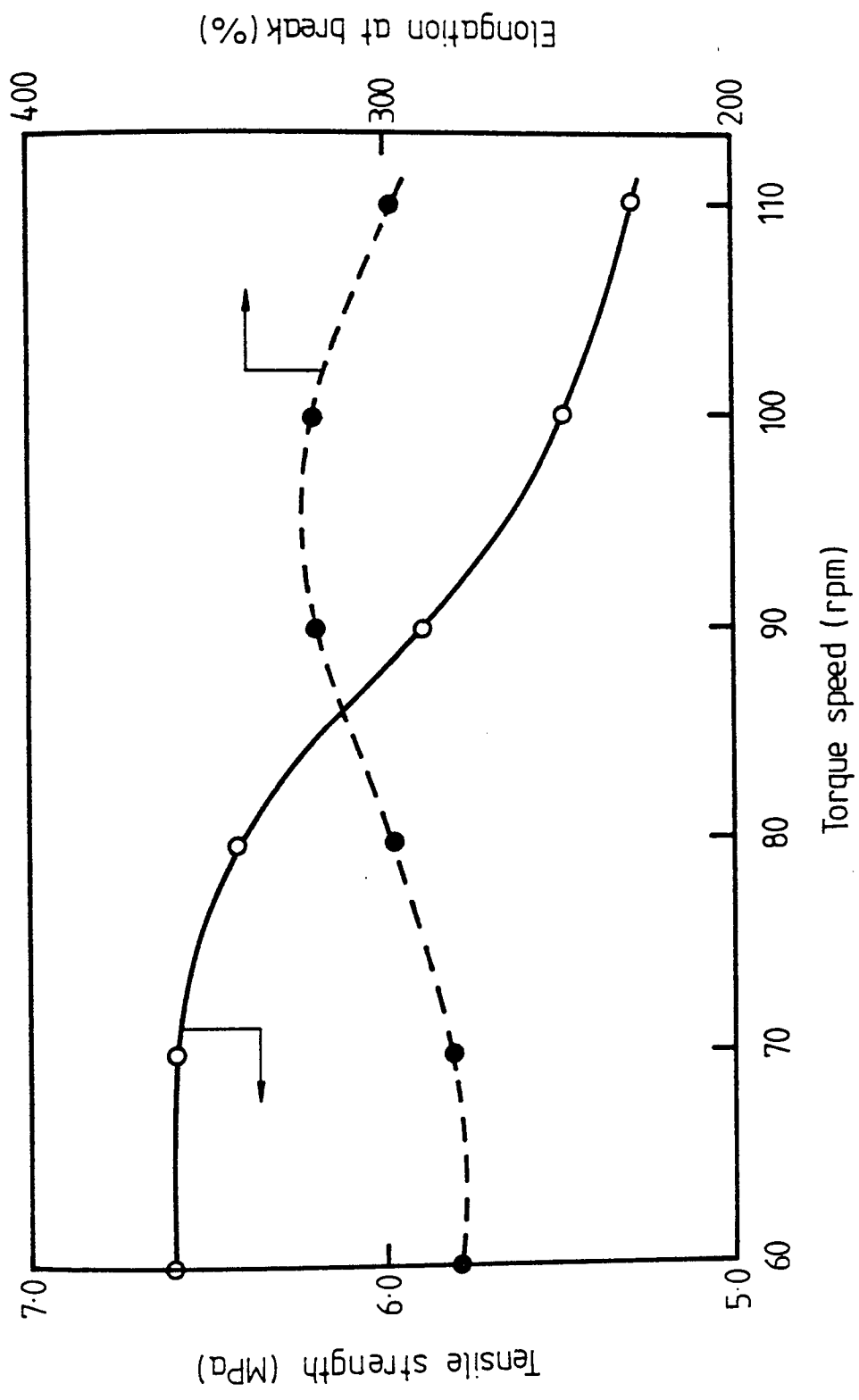

Figure 3.35 - The effect of varying torque speed of the Brabender Torque rheometer on the tensile properties of NR/PP (60/40) blends processed at 160 °C for 10 minutes.

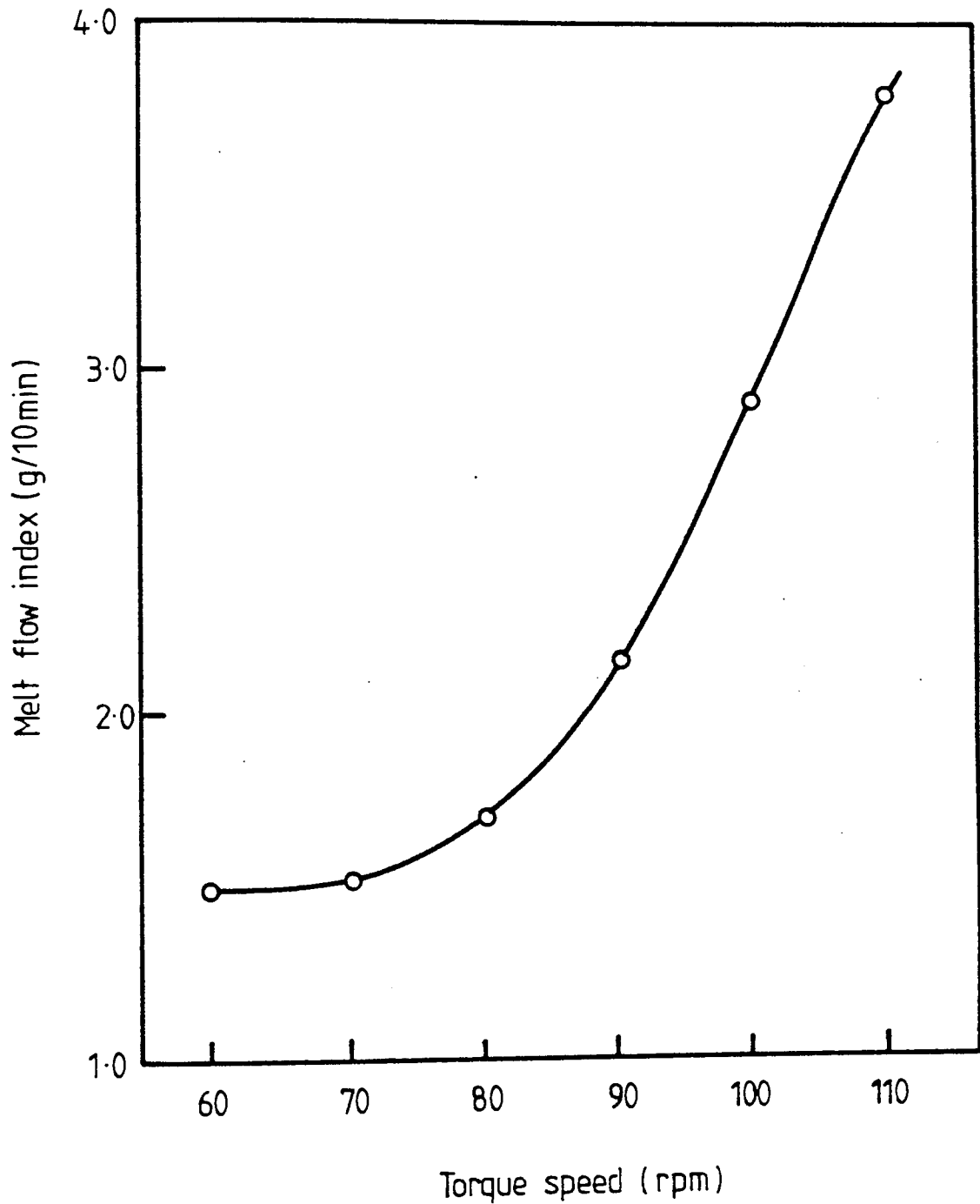

Figure 3.36 - The effect of varying torque speed of the Brabender Torquerheometer on the MFI of NR/PP (60/40) blends processed at 160°C for 10 minutes.

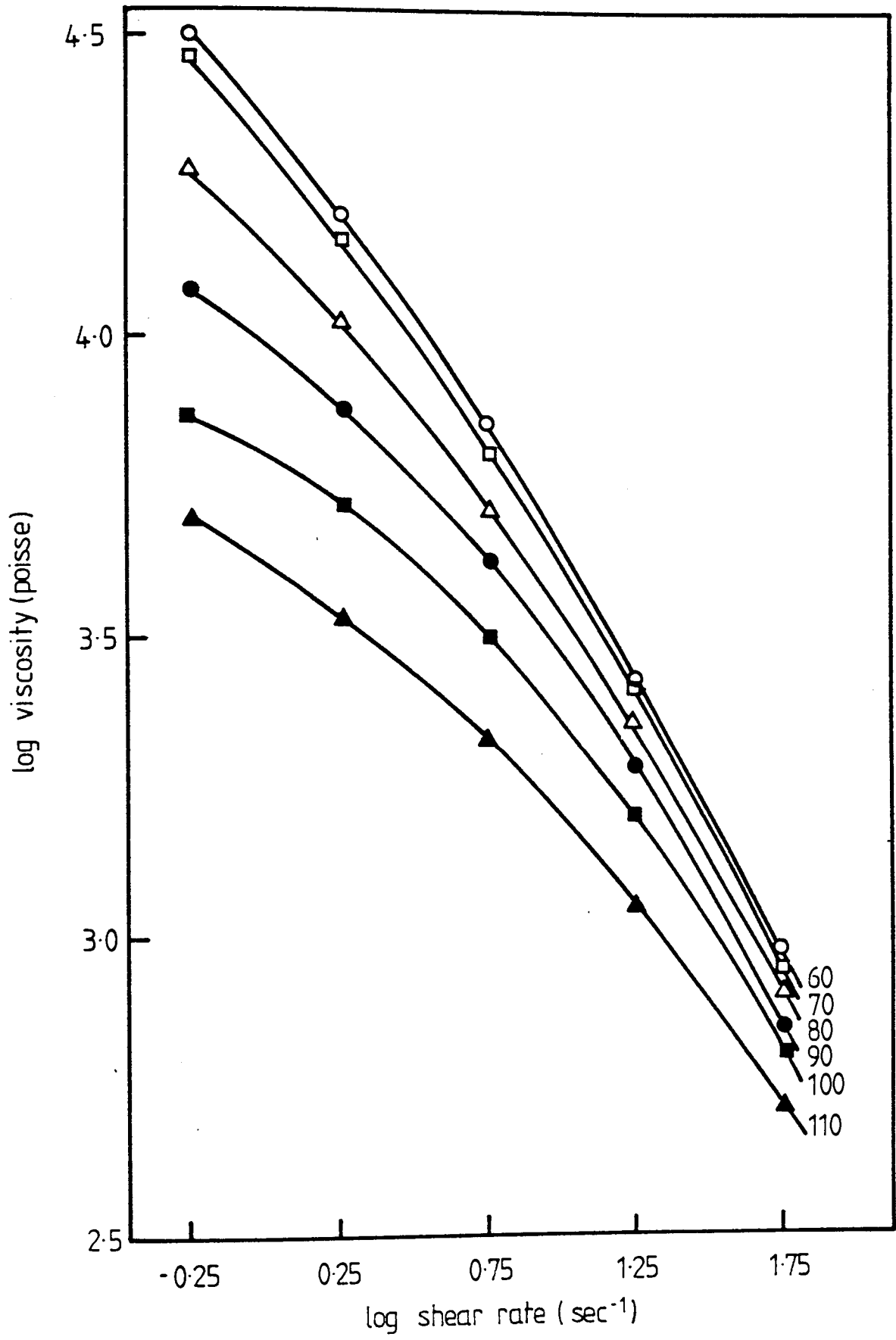

Figure 3.37 - The effect of varying torque speed of the Brabender Torquerheometer on the melt rheology of NR/PP (60/40) blends processed at 160°C for 10 minutes (numbers indicate the torque speed).

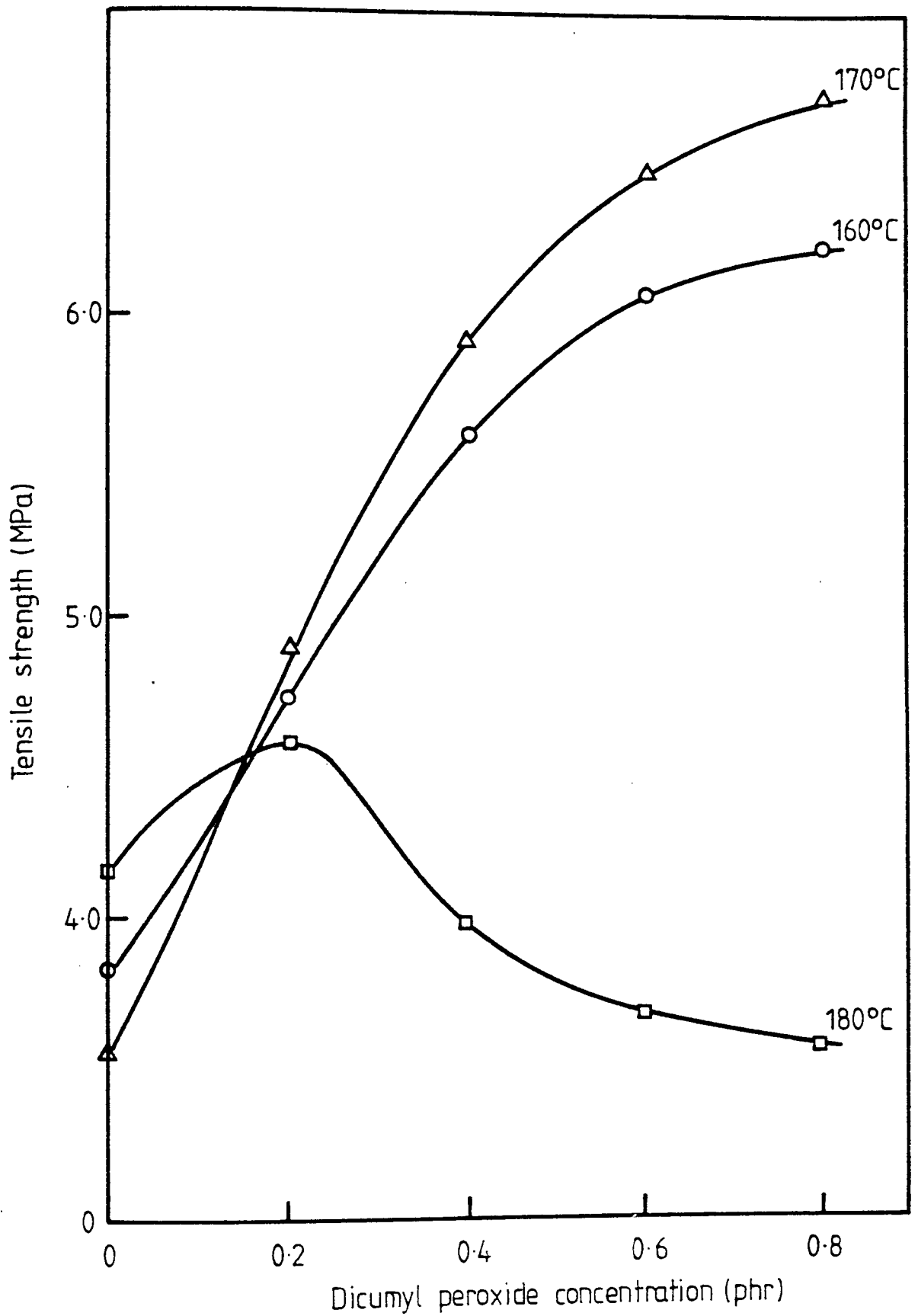

Figure 3.38 - The effect of dicumyl peroxide concentration and processing temperatures on the tensile strength of NR/PP (60/40) (processed with Method B).

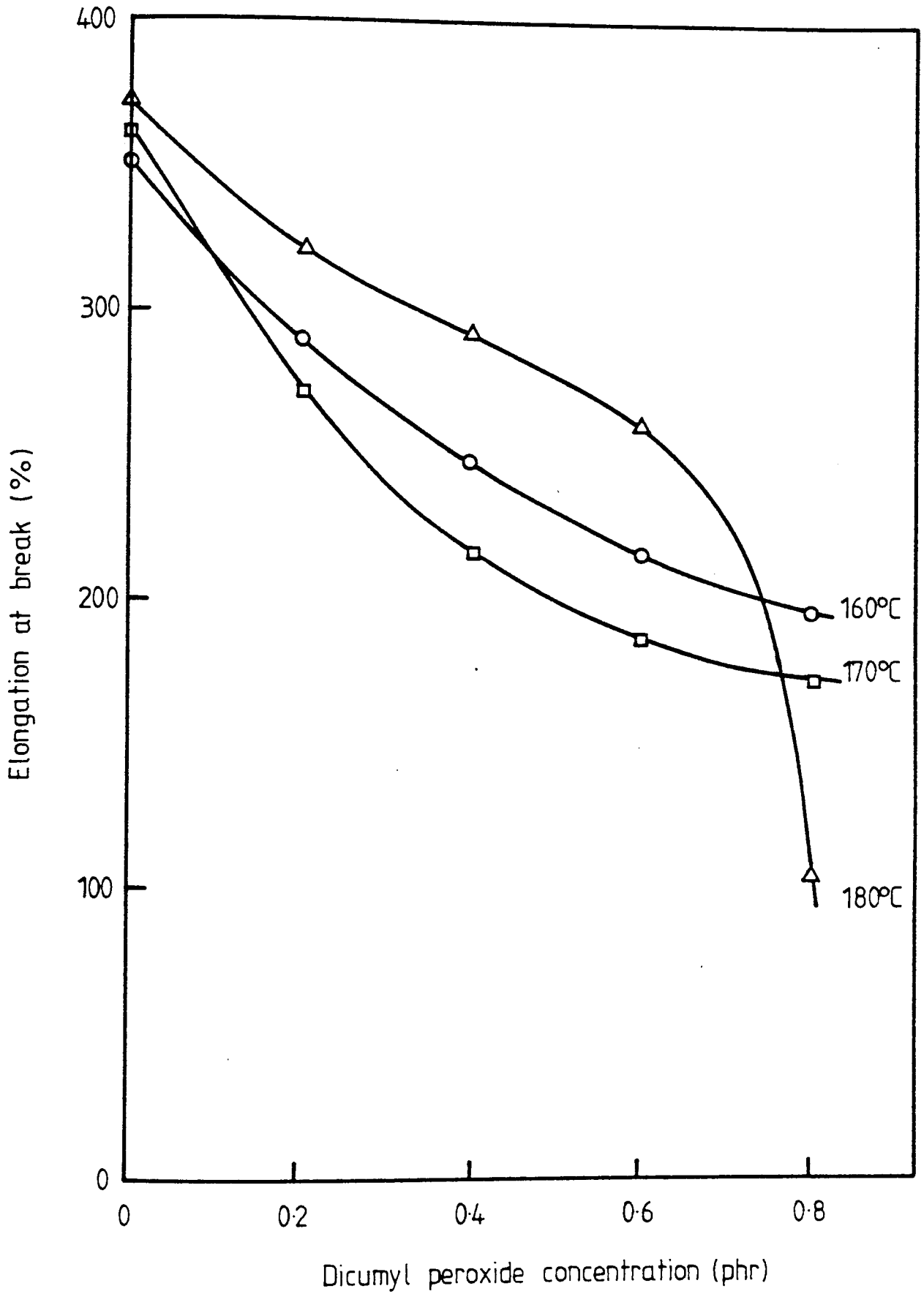

Figure 3.39 - The effect of dicumyl peroxide and processing temperatures on the elongation at break of NR/PP (60/40) blends processed with Method B).



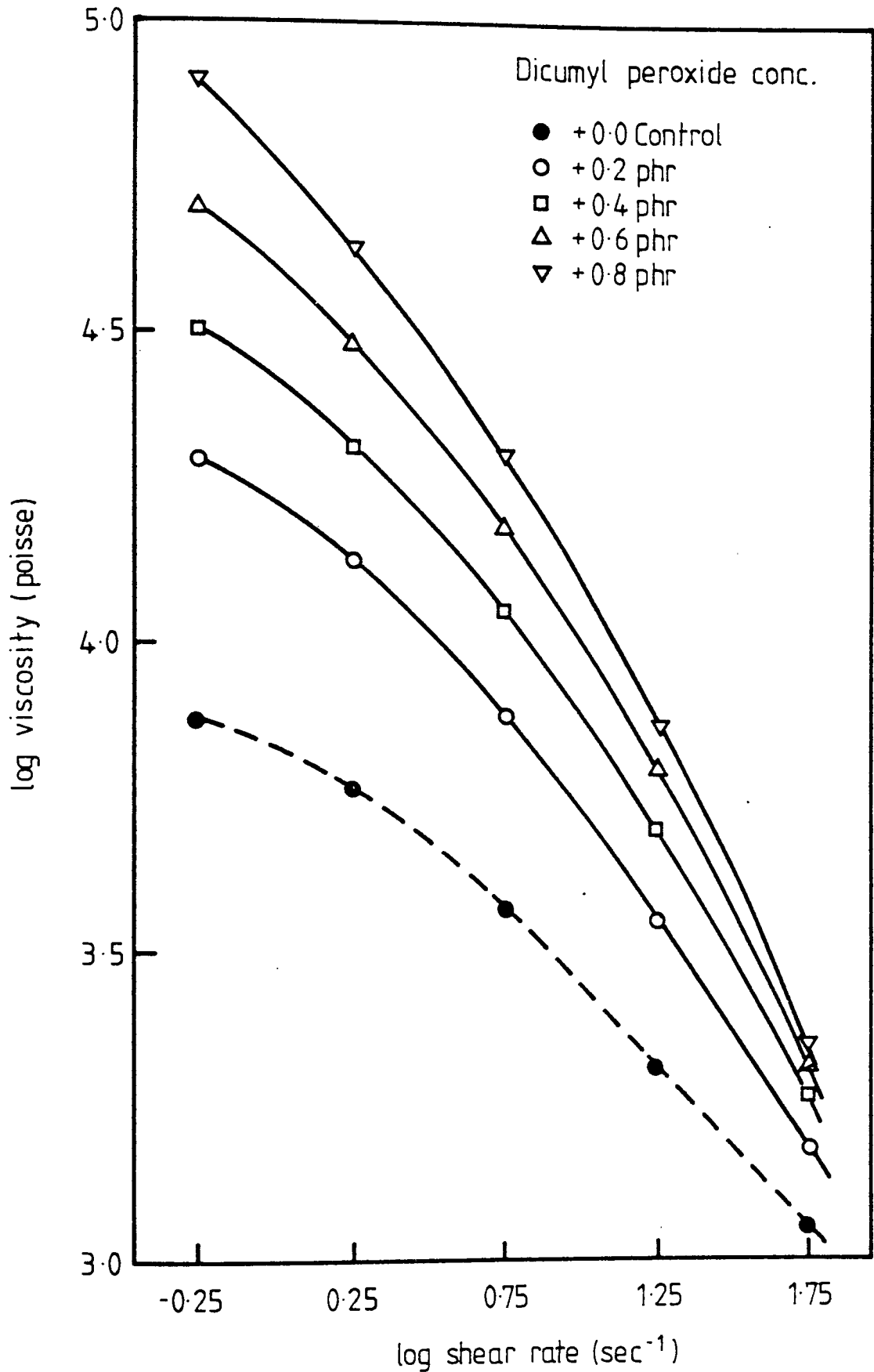

Figure 3.40 - The effect of dicumyl peroxide concentration on the melt rheology of NR/PP (60/40) blends (Method B, processing temperature 160°C).

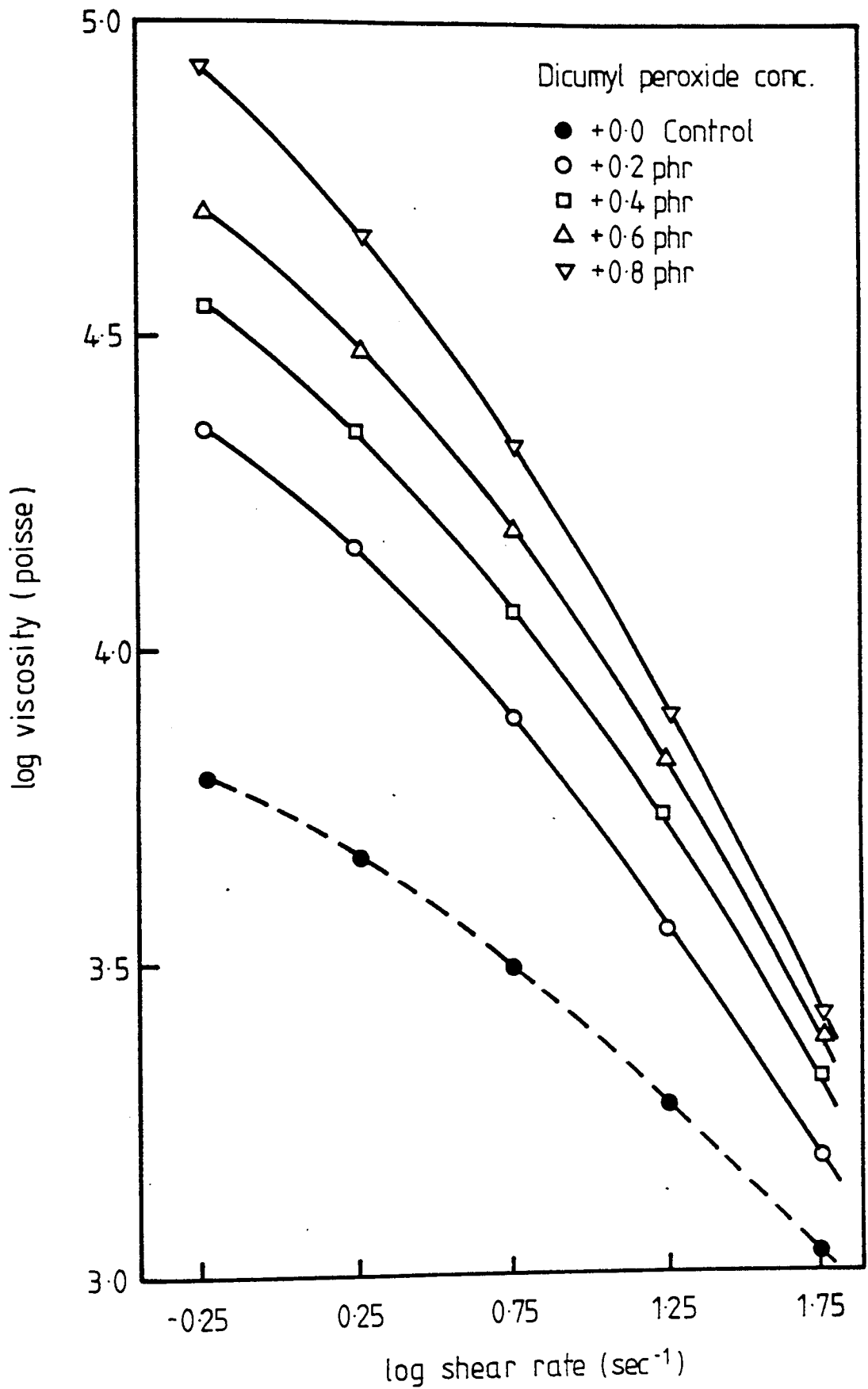

Figure 3.41 -- The effect of dicumyl peroxide on the melt rheology of NR/PP (60/40) blends (Method B, processing temperature 170°C).

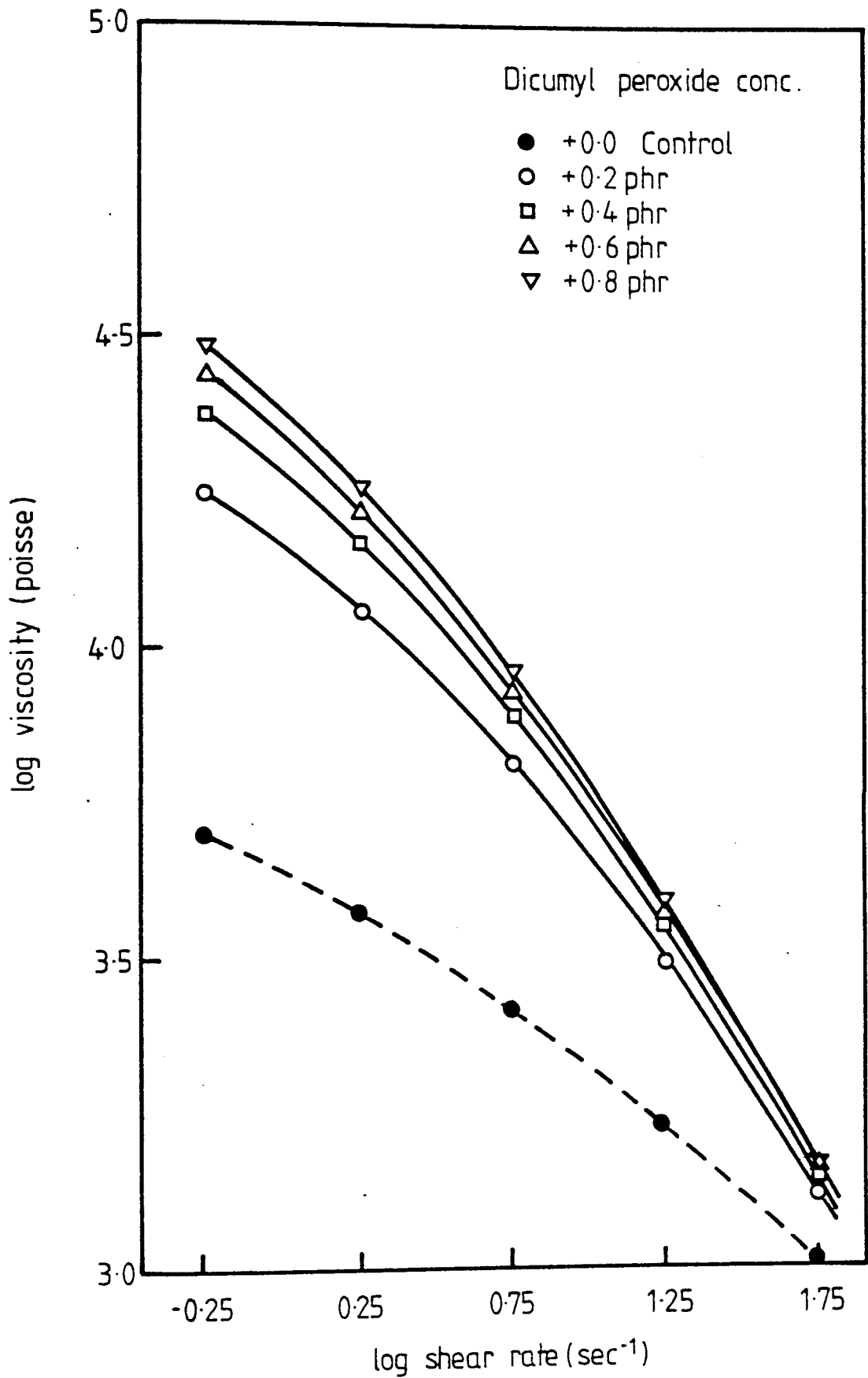

Figure 3.42 - The effect of dicumyl peroxide on the melt rheology of NR/PP (60/40) blends (Method B, processing temperature 180°C).

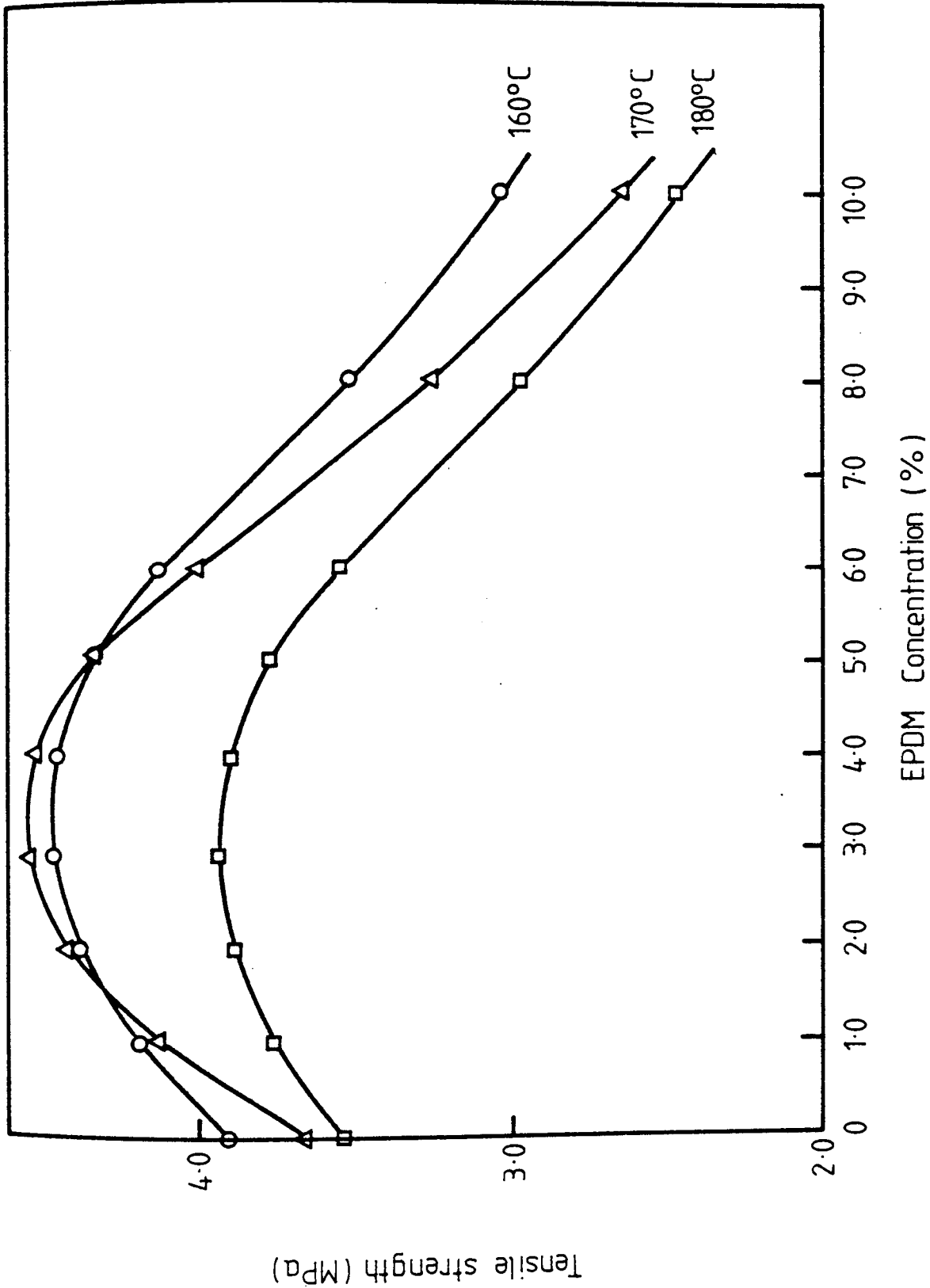
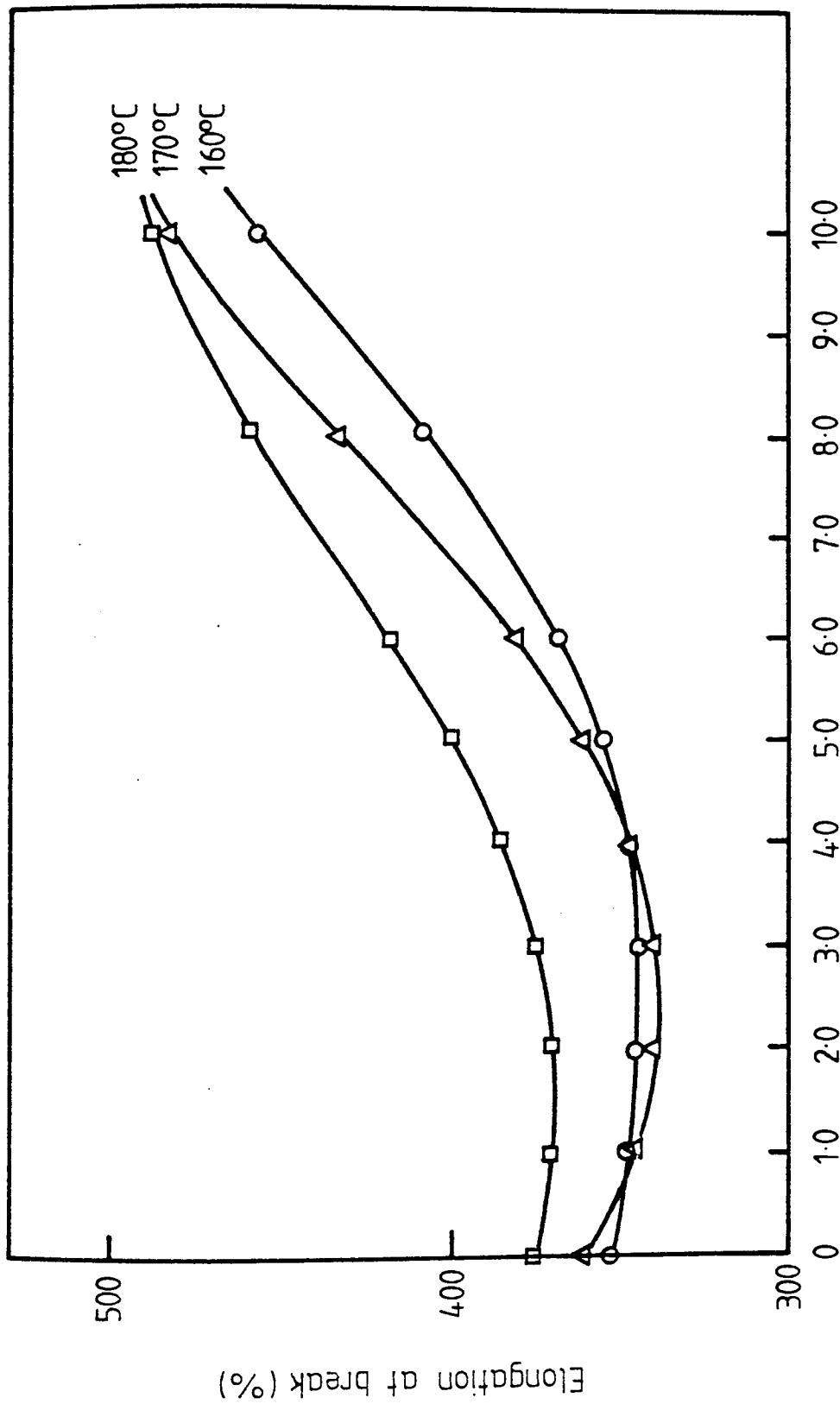

Figure 3.43 - The effect of EPDM and processing temperatures on the tensile strength of NR/PP (60/40) blends processed in a Brabender Torque Rheometer for 7 minutes.



EPDM Concentration (%)

Figure 3.44 - The effect of EPDM and processing temperatures on the elongation at break of NR/PP (60/40) blends processed in a Brabender Torque Rheometer for 7 minutes.

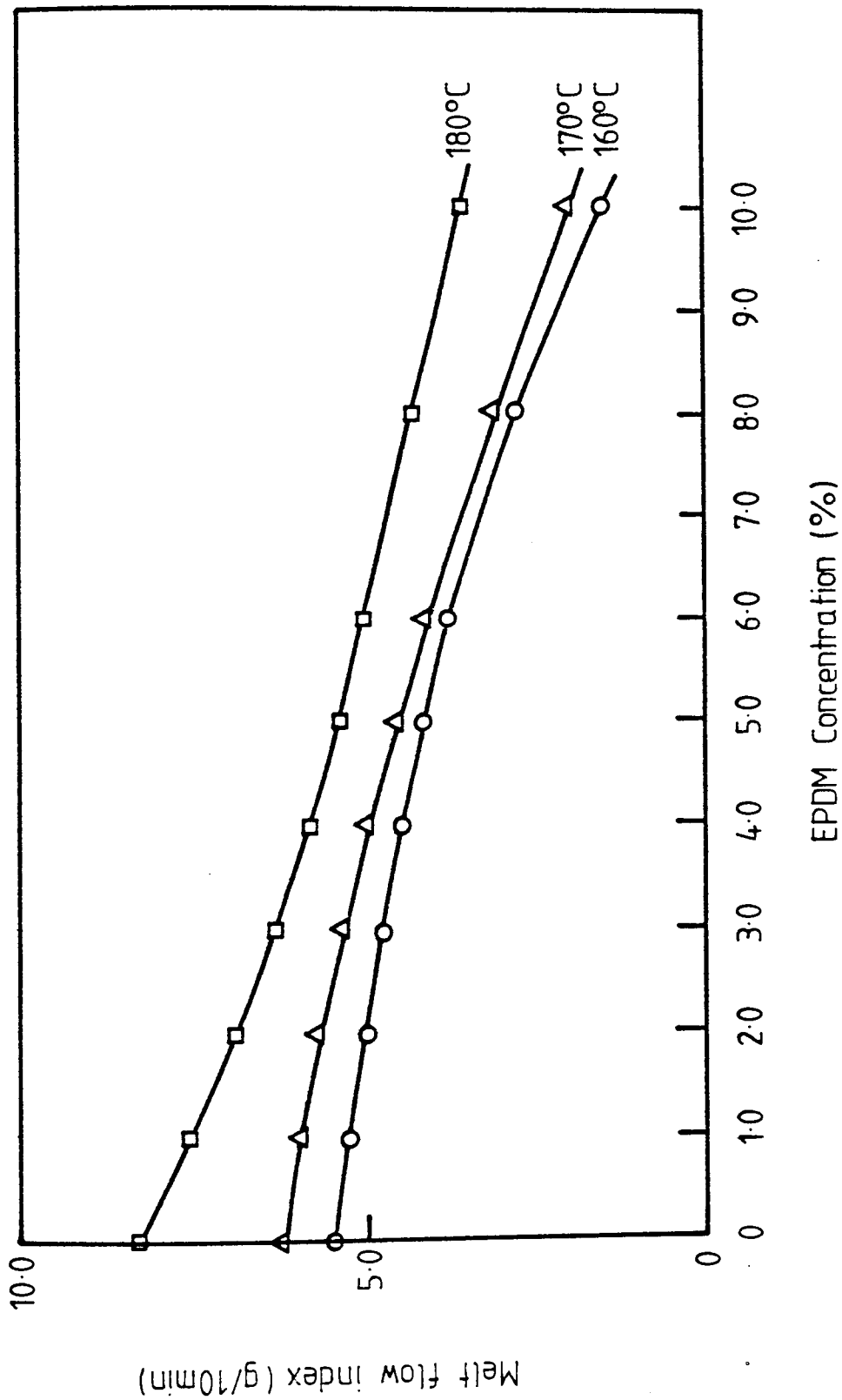

Figure 3.45 - The effect of EPDM and processing temperatures on the melt flow index of NR/PP (60/40) blends processed in a Brabender Torqueheometer for 7 minutes.

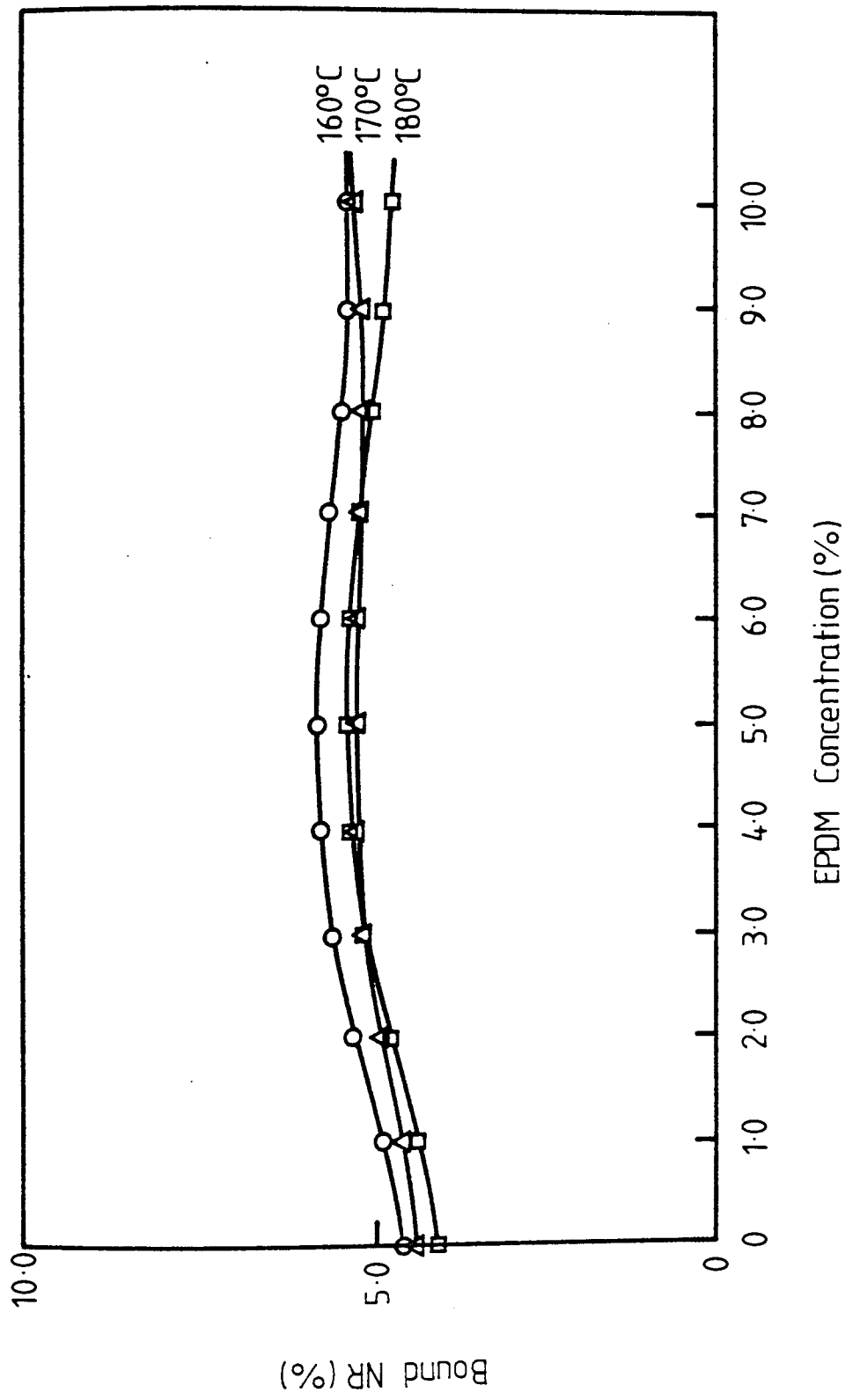

Figure 3.46 - The effect of EPDM and processing temperature on the binding of natural rubber to polypropylene in the NR/PP (60/40) blends, processed for 7 minutes in the Brabender Torque rheometer.

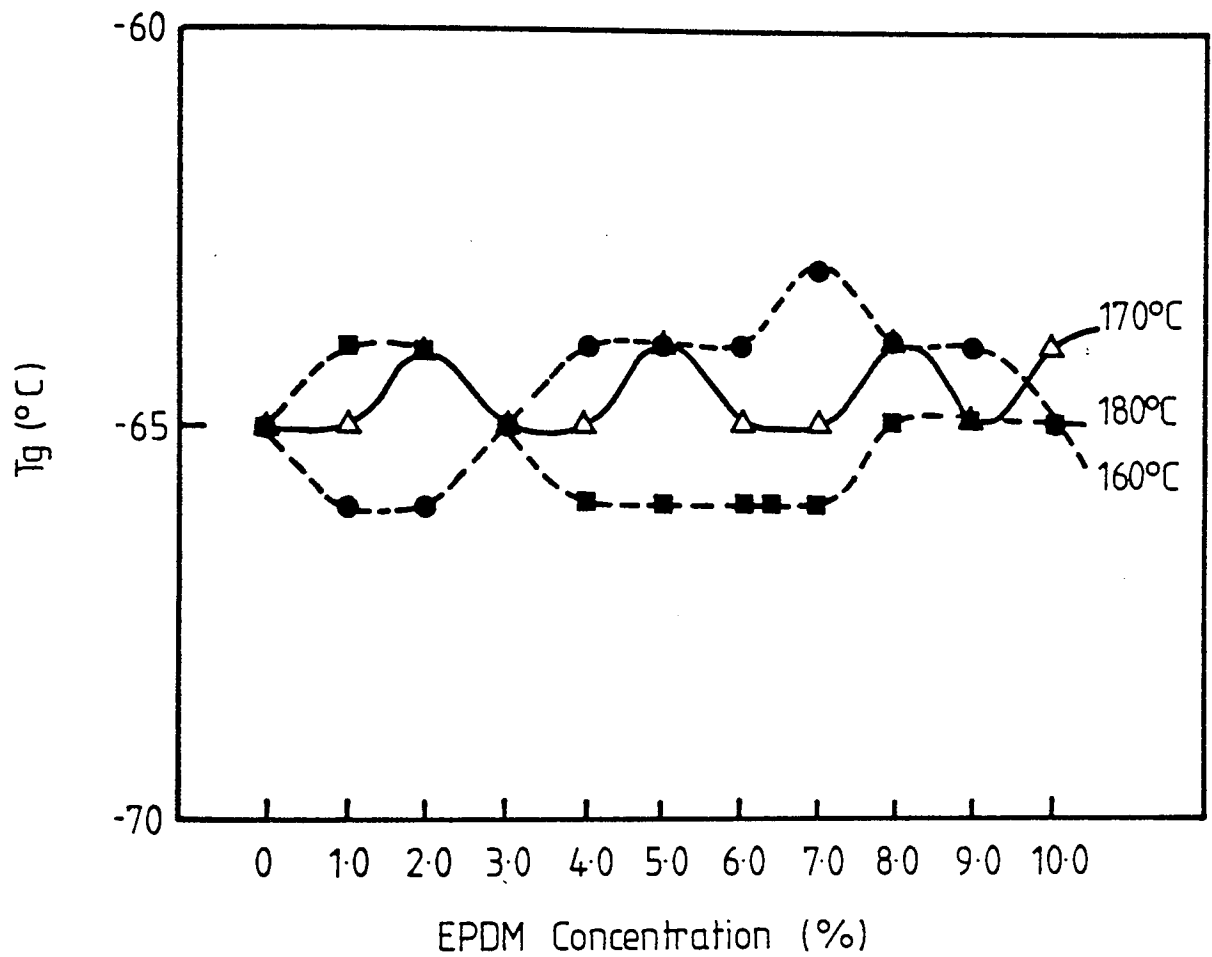

Figure 3.47 - The effect of EPDM on the glass transition temperature ( $T_g$ ) of NR/PP (60/40) blend processed for 7 minutes in the Brabender Torquerheometer.



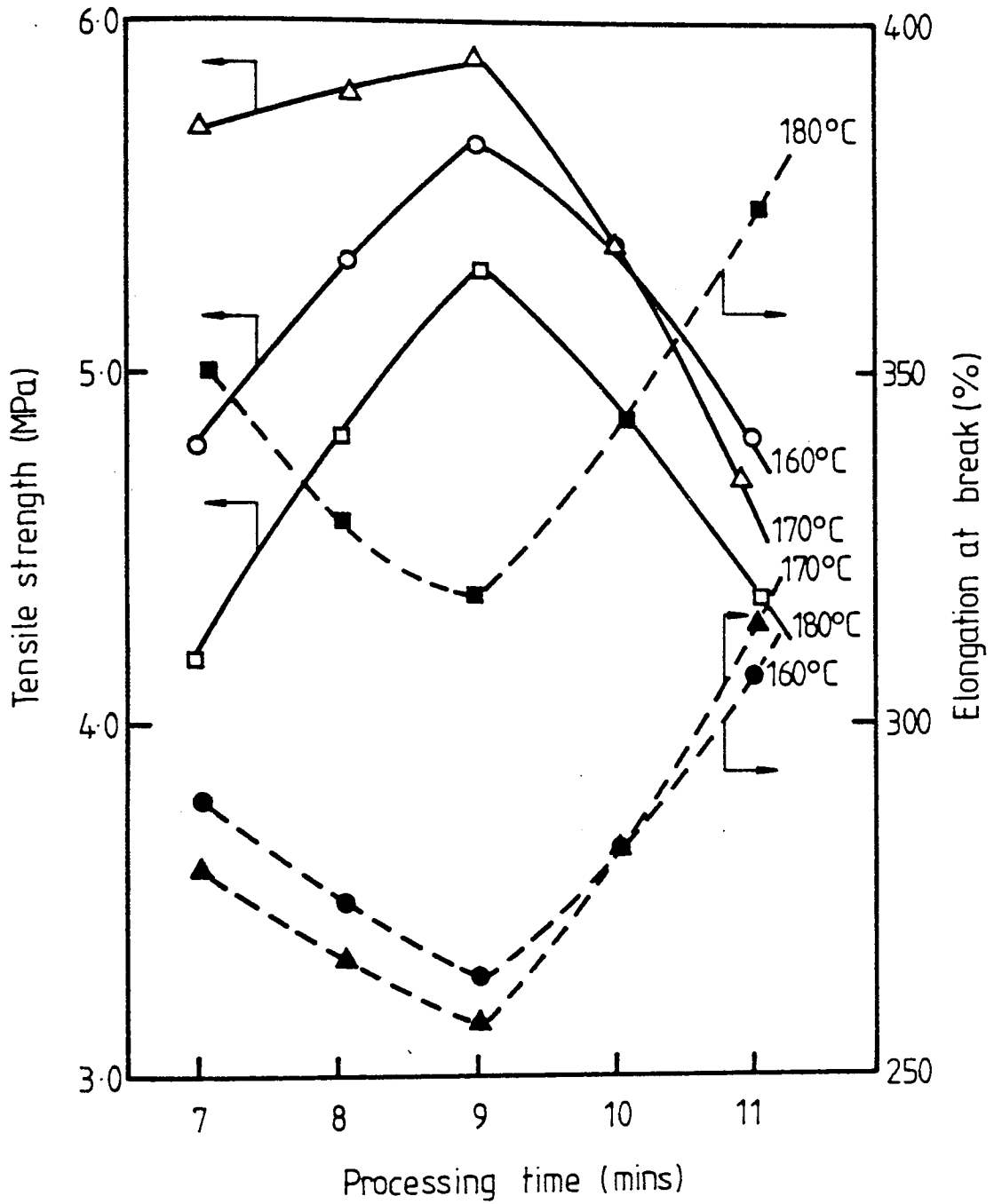

Figure 3.48 - The effect of extending processing time and temperature on the tensile properties of NR/PP (60/40) blends containing 3% EPDM and 0.3 phr. dicumyl peroxide.

CHAPTER FOUR

EFFECTS OF CARBON BLACK AND TYPE OF MIXER  
ON THE PROPERTIES OF NR/PP BLENDS

#### 4.1 Objective

In this chapter, the effect of carbon black loading and type of mixer used in the preparation of NR/PP blends on the properties of the blends are investigated. The optimum loading of carbon black which improves the properties of NR/PP blends was investigated. It has been known that carbon black is the prime reinforcing agent for rubber (typically used at 50 phr)<sup>(128)</sup>. Reinforcement by carbon black gives rise to an increase in abrasion resistance, tear and tensile strength, modulus and related viscoelastic behaviour. It has been generally agreed<sup>(129)</sup> that there is a strong link between rubber chains and reinforcing filler particles, and the properties of such a composite are dependent on this interaction. The effect of combination of carbon black with dicumyl peroxide on the properties of NR/PP blend has also been investigated.

In the preparation of the samples under study (Diagram 4.1), carbon black (concentration 0.40 phr) was mixed with the rubber in an open two-roll mill until well dispersed, then this black compound was used in place of the raw rubber<sup>(132)</sup>. Natural rubber/carbon black-polypropylene (60:40) blends were prepared by Mode A processing method (see Chapter 3, Section 3.1) in the Brabender Torque rheometer at 160°C for 10 minutes. Film samples were prepared by compression moulding as described in

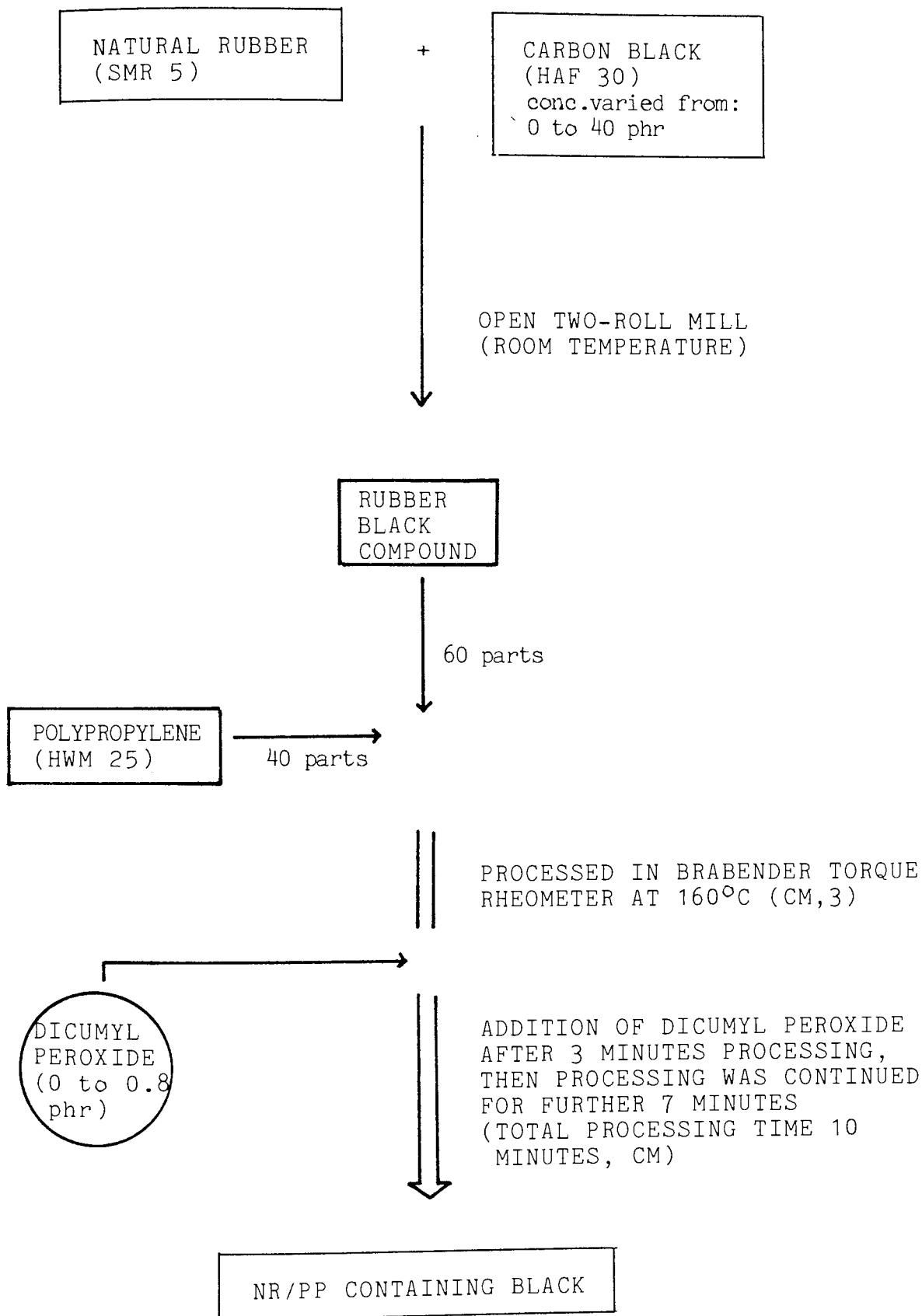

Diagram 4.1 Schematic operation of the preparation of NR/PP(60/40) containing carbon black

Chapter 2, Section 2.2. Tensile properties, melt flow index and melt rheology were monitored.

The effect of mixing procedure (using different processing machines) of NR/PP blends on the initial properties, thermal and photo-oxidative stabilities of NR/PP blends was studied. Natural rubber and polypropylene (weight ratio 60:40) were processed in a Banbury mixer at 150°, 160° and 170°C followed by the addition of dicumyl peroxide (0.3 phr) and mixing was then continued for a further 4 minutes (Diagram 4.2). In the second set of experiments, natural rubber and polypropylene (weight ratio 60:40) and dicumyl peroxide (0.3 phr) were fed together into a Busko Kneader and processed at 150°, 160° and 170°C. About 25 g samples were taken from both machines and films were compression moulded, while the rest was granulated for injection moulding (see Chapter 2, Section 2.2). Testings carried out for injection moulded samples were tensile properties, flexural properties, melt flow index and thermal-oxidative and dimensional stability. Re-compression moulding of the film samples and reinjection moulding were carried out to study thermal-oxidative stability during fabrication and the possibility of recycling the scraps and rejects.

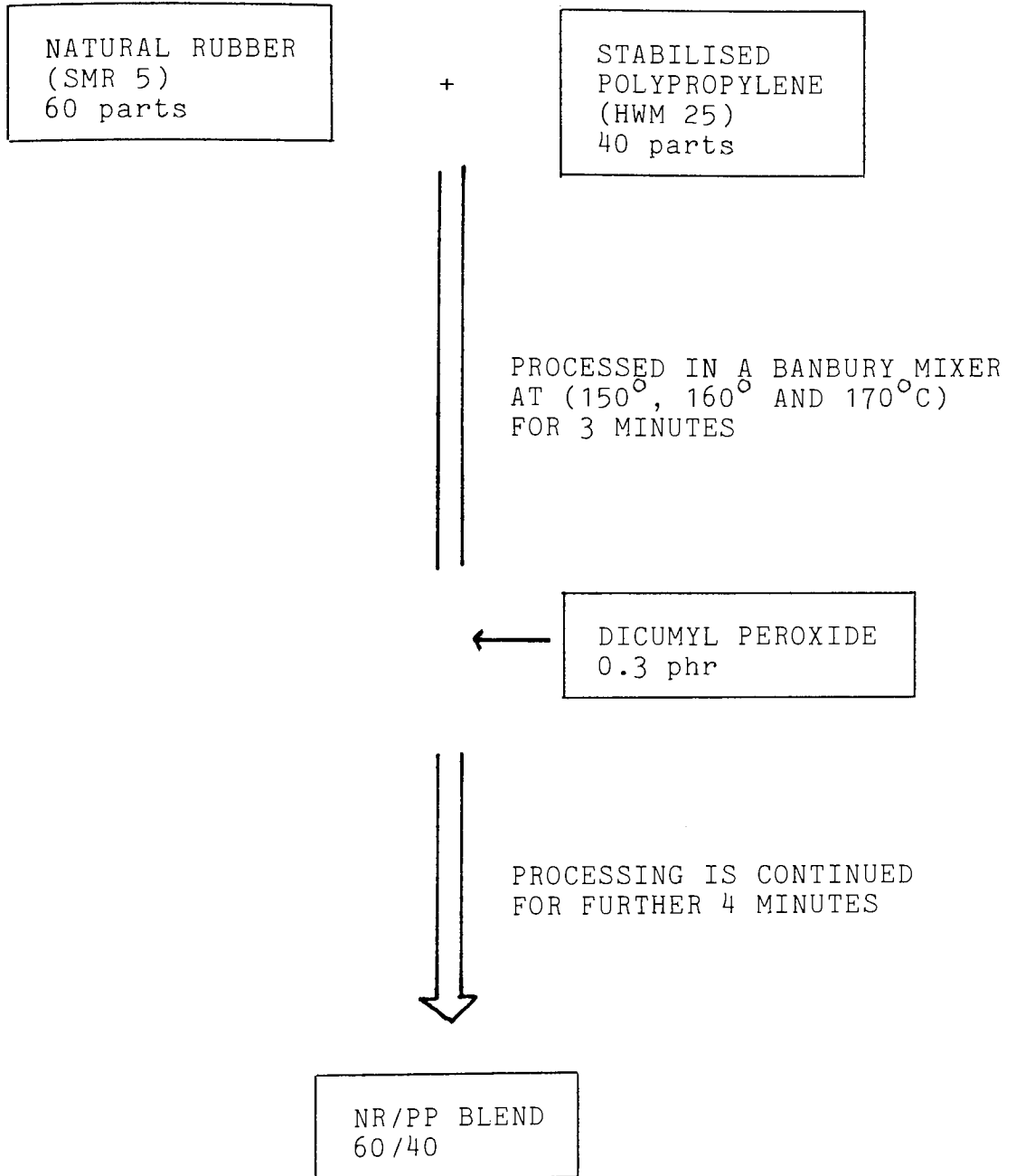

Diagram 4.2 Schematic operation of the preparation of NR/PP(60/40) blends in the Banbury mixer.

## 4.2 Results and Discussion

### 4.2.1 Effect of Carbon Black on the Properties of NR/PP (60/40) Blends

The effect of concentration of carbon black on tensile behaviour of NR/PP/black (60/40) blend is shown in Figure 4.1. It is clear that the addition of carbon black only slightly increases the tensile strength of the blends, which occurs at a loading of 10 phr; at higher loading, tensile strength decreases. Elongation at break decreases with increasing carbon black loading. The absence of a crosslinking agent and the high processing temperature would explain this and suggest an insignificant carbon black-rubber interaction. It has also been suggested<sup>(130,131)</sup> that filler particles provide means of stress relief. According to Bueche's Mechanism<sup>(130)</sup>, it was shown that carbon black aggregates are linked by rubber molecules of different chain lengths. When the sample is stretched to the point where the shortest molecules break, the longer ones carry the load. While according to the molecular slippage mechanism<sup>(131)</sup>, it is assumed that rubber molecules are not rigidly attached to the carbon black but can slip along the surface. On stretching, the slippage allows the stress relief and prevents bond breakage.

The effect of carbon black on the tensile modulus of the blends is shown in Figure 4.2. It is clear that the

tensile modulus increases with increasing carbon black loading. It is known that stiffness of rubber increases with increasing carbon black loading and that this only depends on the shape and concentration of filler particles<sup>(133)</sup>. Studebaker<sup>(134)</sup> found that the Mooney viscosity (a measure of unvulcanised rubber mix) increases with increasing carbon black loading. The rheology behaviour of the blends (Figure 4.3) shows that viscosity increases with increasing carbon black loading. This does not necessarily mean, however, that there has been an increase in molecular weight, but the increase may be due to the presence of carbon black particles which cause the perturbation of flow, as will be discussed later in this chapter.

The effect of combination of carbon black and dicumyl peroxide on the tensile properties of the blends is shown in Figures 4.4 to 4.6. It is clear that concentration of carbon black higher than 10 phr decreases the tensile strength of NR/PP blends containing dicumyl peroxide (Figure 4.4). The elongation at break of the blends (Figure 4.5) is similarly affected by carbon black as is its tensile properties; it decreases with increasing carbon black loading and dicumyl peroxide concentration. However, the tensile modulus of the blends increases with increasing concentration of dicumyl peroxide and of carbon black (Figure 4.6).



Based on these results, it is apparent that there are two different factors affecting properties of the NR/PP blend when carbon black is added. The increase in tensile modulus is likely to be due to the effect of carbon black on the rubber phase. It is known<sup>(135)</sup> that the addition of carbon black into rubbers reduces the molecular mobility of rubber molecules which results in an increase in the stiffness. On the other hand, increasing loading of black leads to reduction in tensile properties e.g., tensile strength and elongation at break which render the blends more brittle as reflected from its poor strength (Figures 4.1, 4.2, 4.4 and 4.5). This may be due to the dilution effect of the filler<sup>(136)</sup>, due to diminishing volume fraction of the polymer. At higher loading of carbon black, polymer matrix is not enough to hold the filler particles together. The unbound carbon black will act as foreign particles in the polymer matrix hence introducing structural inhomogeneities<sup>(137)</sup>. When the matrix is subjected to stress, these particles will act as crack initiators which introduce highly localised sites of weakness. Van Rossem<sup>(138)</sup> found that there is a correlation between the energy of rupture with load of carbon black; the energy of rupture decreases with increasing black loading.

A second reason may be due to molecular break down effect. It has been widely known that in most cases, when carbon black is added to elastomers it increases the viscosity<sup>(139,140)</sup>

Einstein<sup>(141)</sup> suggested that the increase in viscosity of a liquid due to the addition of spherical particles, as being due to the perturbation of flow caused by rotation of particles as the liquid is sheared. Einstein's formula given for simple viscosity of suspension states:

$$\eta = \eta_o (1 + 2.5\phi) \quad (4.1)$$

where  $\eta$  and  $\eta_o$  are viscosity of suspension and viscosity of the liquid respectively and  $\phi$  is volume fraction of particles. Guth and Gold<sup>(142)</sup> derived a theoretical equation for such mixtures which is applicable for higher concentrations (polymer and fillers) as:

$$\eta = \eta_o (1 + 2.5\phi + 14.1\phi^2) \quad (4.2)$$

From which it is apparent that the viscosity of polymer containing carbon black must increase with increasing carbon black loading. Melt flow index and rheological measurement results of the NR/PP blends studied here show an increase in viscosity of the blends due to increasing carbon black loading (Figures 4.7 to 4.10). The effect of carbon black on the viscosity does not only occur in rubbers<sup>(140,143)</sup>, but also in plastics<sup>(144)</sup> e.g., it was found<sup>(144)</sup> that the melt flow index of polyethylene decreases with increasing carbon black (HAF) loading.

The effect of increase in the viscosity gives rise to many disadvantages, such as molecular break down and

inhibited crystallisation. As the viscosity increases, the energy of mixing increases resulting in high imposed shear forces and therefore causes molecular chain cleavage<sup>(145)</sup>. Even though the cleavages occur in the crosslinked phase, it will still affect the strength of the elastomer since the short chains break early when the material is subjected to tensile stress and the longer chains will carry the stress<sup>(130)</sup>. Therefore, the shorter the chain, the lower the strength<sup>(136)</sup>.

Boonstra<sup>(144)</sup> reported that high viscosity of polyethylene filled with HAF carbon black prevents the growing crystallites from pushing the carbon particles into the remaining amorphous area and as a consequence, crystallite growth is inhibited. This may happen in the polypropylene phase of NR/PP blends studied here. Since the crystalline region of polypropylene is one determining factor for the strength of the blends (as "pseudo-crosslinks"), the inhibition of crystallisation caused by increasing carbon black loading will be expected to lower the overall strength of the blends.

#### 4.2.2 Effect of Type of Mixer on the Properties of NR/PP Blends

##### 4.2.2.1 Compression Moulded Films

###### a. Physical Properties

Table 4.1 shows the properties of films of NR/PP(60:40)

Type of mixer	Processing temperatures(°C)		
	150	160	170
<u>Brabender Torque rheometer</u>			
Tensile strength (MPa)	-	6.70	5.80
Elongation at break (%)	-	3.40	330
Tensile modulus (MPa)	-	60	60
MFI (g/10 min)	-	1.2	1.0
<u>Busko Kneader</u>			
Tensile strength (MPa)	7.80	7.80	7.30
Elongation at break (%)	340	360	380
Tensile modulus (MPa)	65	65	60
MFI (g/10 min)	1.6	1.8	1.9
<u>Banbury mixer</u>			
Tensile strength (MPa)	7.30	7.30	7.00
Elongation at break (%)	330	330	360
Tensile modulus (MPa)	66	67	62
MFI (g/10 min)	1.5	1.8	1.8

Table 4.1 Physical properties of natural rubber blends processed in Busko Kneader, Banbury mixer and Brabender Torque rheometer at different temperatures (compression moulded samples)

blends when processed initially in a Busko Kneader, a Banbury mixer and a Brabender Torque rheometer at different temperatures. It is seen that blends processed in the Busko Kneader and the Banbury mixer have, in general, better physical properties than those processed in the Brabender Torque rheometer. This suggests that a better dispersion between natural rubber and polypropylene phases in the blends has been obtained from both the Banbury and the Busko Kneader due to a higher shearing force. In the case of natural rubber, high mechanical shear forces rupture the molecular chains such as in mastication process<sup>(146,147)</sup>. This process, therefore, leads to a decrease in viscosity of the rubber, which is desirable in achieving a similar viscosity to that of polypropylene in order to have a better dispersion.

Processing temperature seems also to have a significant effect on the properties of these blends (Table 4.1). At 170°C, the properties are lower than those of similar blends processed at 150°C and 160°C in all processing mixers used. The combination of high shearing forces and high temperature causes degradation of the blends as reflected in their melt flow index values. It is apparent then that processing temperature of 160°C in the Banbury and the Busko Kneader is quite adequate.

b. Thermal Degradative Stability of the Blends

Thermal oxidative stability of films of NR/PP blends was examined by following the changes in the physical properties after recompression moulding at 180°C. Figures 4.11 and 4.12 show the effect of recompression moulding on tensile properties and melt stability of blends processed in the Brabender, the Banbury and the Busko Kneader at 160°C. It is seen that, in all cases, the properties are retained up to 3 times reprocessing but decline sharply after further recompression moulding. This coincides with only little change in MFI (Figure 4.12) after 3 times recompression moulding but which increases sharply after this. The materials tested here, therefore, behave like thermoplastic. Generally, blends processed in the Brabender Torque rheometer show better thermal stability after 3 times of recompression moulding compared to corresponding blends processed in the Busko Kneader and the Banbury (Figure 4.11). This may be due to the processing conditions (i.e., high mechanical shear and temperature) in the Busko Kneader and the Banbury, which give rise to precursors responsible for subsequent thermo-oxidative degradation during recompression moulding.

c. Photo-oxidative Stability

Figure 4.13 shows the effect of ultra-violet irradiation

on the carbonyl group of the blends. It is clear that carbonyl groups increase very rapidly with irradiation time. Figures 4.14 and 4.15 show the corresponding deterioration in tensile properties of these blends during ultra-violet irradiation. Blends processed in the Brabender Torque rheometer show slightly better properties during UV-irradiation compared to properties of the corresponding blends when processed in the Banbury and the Busko Kneader.

Based on these results, it is shown that NR/PP(60:40) blends studied here are quite susceptible both to high temperatures and to ultra-violet light. This is expected, since natural rubber has higher level of unsaturation and hence the higher levels of formation of functional groups such as hydroperoxide and carbonyl during processing. The presence of unsaturation in polymers markedly reduces their oxidative stability<sup>(148)</sup>. During processing, polymers are subjected to high temperature and shearing forces which results in the formation of hydroperoxide (Scheme 4.1). It has been found that during the milling process of natural rubber, hydroperoxides are formed rapidly and their concentration is related to the milling time<sup>(149)</sup>.

Consequently, under conditions of high temperature-recompression moulding, these macro-hydroperoxides will act as sites for further thermo-oxidation leading to chain scission, which is reflected in the increase

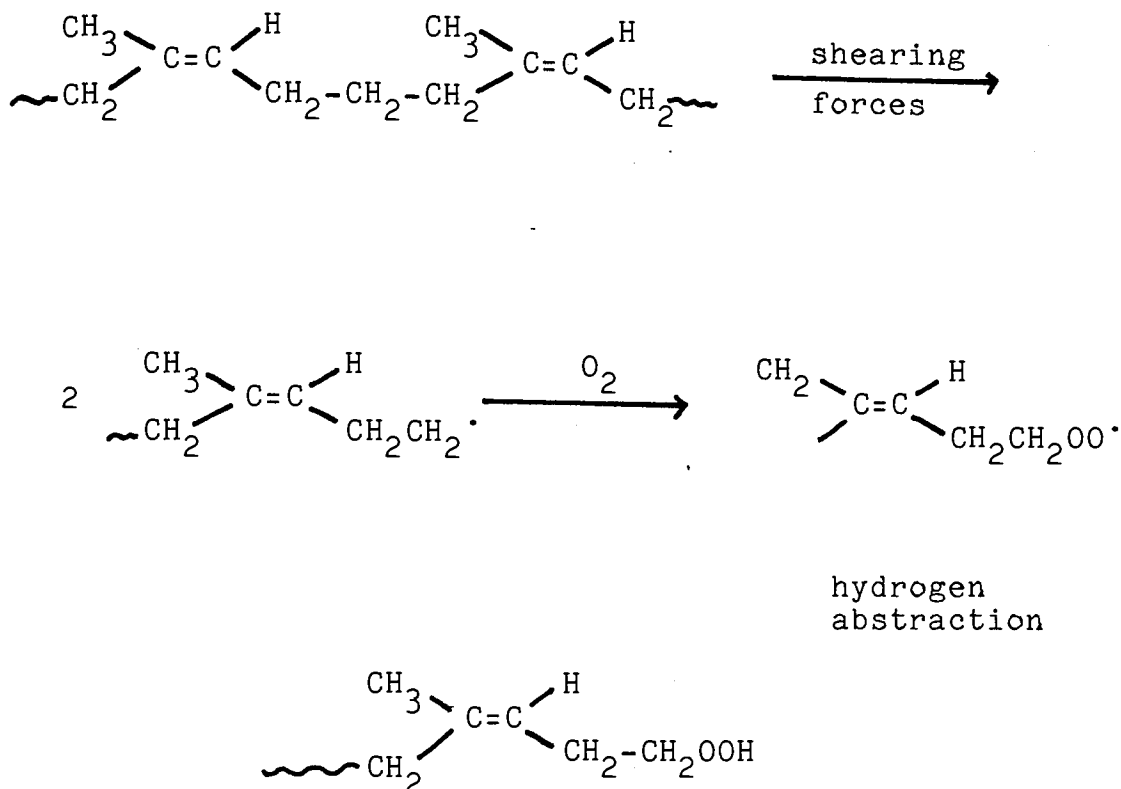

Scheme 4.1 Formation of hydroperoxide in natural rubber during milling<sup>(149)</sup>

in MFI (Figure 4.12). The decrease in molecular weight (increase in MFI) leads to the deterioration in tensile properties (Figure 4.11). While under conditions of UV-irradiation, hydroperoxides act as photo-activators for the oxidation and since they are the most important source of free radicals<sup>(149)</sup> in the system, the oxidation rate depends upon the thermal processing history of the blends. This is why blends processed in a Busko Kneader are more susceptible to UV-light than those corresponding blends processed in the Banbury and the Brabender Torque rheometer. The former blends are subjected to higher shearing forces, therefore more hydroperoxides are expected to be



formed. As a result, higher level of carbonyl groups is produced during UV-irradiation (Figure 4.13) and this results in a faster deterioration in properties (Figures 4.14 and 4.15).

It is also interesting to note that blends produced in the Busko Kneader have slightly better properties than corresponding blends processed in the Banbury and the Busko Kneader (Table 4.1), but they have lower stability in subsequent thermal and photo-oxidation.

#### 4.2.2.2 Injection Moulded Samples

##### a. Physical Properties

Table 4.2 summarises the initial properties of NR/PP blends processed in different mixers from injection moulded samples. It is apparent that similar to the case of compression moulded samples, the initial properties of blends processed in the Busko Kneader are higher than those of blends processed in the Banbury and the Brabender. The higher shearing forces involved in the Busko Kneader facilitate a better dispersion of natural rubber and polypropylene in the blend.

Type of mixer	Processing temperatures (°C)		
	150	160	170
<u>Brabender Torque rheometer</u>			
Tensile strength (MPa)	-	7.60	7.30
Elongation at break (%)	-	390	350
Tensile modulus (MPa)	-	63	60
Flexural modulus (MPa)	-	145	136
Flexural strength (MPa)	-	13	13
MFI (g/10 mins)	-	1.1	1.2
<u>Busko Kneader</u>			
Tensile strength (MPa)	10.20	9.50	8.2
Elongation at break (%)	340	360	370
Tensile modulus (MPa)	75	70	67
Flexural modulus (MPa)	162	155	148
Flexural strength (MPa)	18	16	15
MFI (g/10 mins)	1.6	1.8	2.0
<u>Banbury mixer</u>			
Tensile strength (MPa)	9.10	8.30	7.50
Elongation at break (%)	360	360	380
Tensile modulus (MPa)	68	65	65
Flexural modulus (MPa)	150	145	140
Flexural strength (MPa)	15	13	13
MFI (g/10 mins)	1.4	1.6	1.8

Table 4.2 Initial properties of NR/PP blends processed in Busko Kneader, Banbury mixer and Brabender Torque rheometer at different temperatures (injection moulded samples)

b. Re-injection moulding and oven-ageing.

Figures 4.16 and 4.17 show the effect of re-injection moulding on the physical properties of NR/PP(60:40) blends. These results reveal that all properties are seriously affected by re-injection moulding. They decrease significantly with increasing number of re-injection moulding. Tensile strength of blends processed in the Busko Kneader decreases by a factor of 6 when they are re-injection moulded for 7 times, while for blends processed in the Banbury and the Brabender by a factor of 2.8 and 1.9 respectively. Elongation at break seems to be affected to a lesser extent. Flexural modulus and strengths also deteriorate with increasing number of re-injection moulding (Figure 4.17), and it is clear that blends processed in the Busko Kneader are badly affected by re-injection moulding. Figure 4.18 shows that tensile modulus decreases with increasing number of re-injection moulding while MFI increases commensurately. It is clear that re-injection moulding causes severe degradation of the blends as reflected in the increase in melt flow index. However, from these results it is quite clear that NR/PP (60:40) blends studied here are capable of being recycled. In order to prevent degradation caused by the recycling operation, hence improve subsequent physical properties, anti-oxidants must be used.

Figures 4.19 to 4.21 show the effect of oven ageing of injection moulded samples on the physical properties. It is clear that NR/PP(60:40) blends retain their properties for up to seven days during oven ageing at 50°C. At higher temperatures however (inset Figures 4.19 and 4.20), NR/PP blends show a considerable loss in tensile and flexural properties. At 100°C, the tensile strength falls by almost 50% of its initial value after 3 days. From these results, it is obvious that NR/PP(60:40) blends have a poor ageing resistance at high temperature (100°C). It was found<sup>(150)</sup> that NR/PP(50/50) blends containing various stabilisers (e.g., DLTP, DSTDP, Tinuvin 327) are remarkably resistant to heat ageing. For example, the effect of ageing test pieces for seven days at 100°C causes a fall in tensile strength by only 10%, while the tensile strength of vulcanised rubber falls by more than 50%. Kuzminskii and Lyubchanskaya<sup>(151)</sup> have pointed out that natural rubber vulcanisate is less stable at high temperature due to its higher apparent activation energy ( $\Delta E$ ). It was shown in their experiment with a variation of ageing temperatures of natural rubber vulcanisates that at 90°C, the half life time ( $t_{\frac{1}{2}}$ ) was 12 days, while at 70°C and 50°C it was 65 and 410 days respectively. Based on these facts, therefore, in the case of NR/PP blends studied here, its lower ageing resistance at 100°C must not be entirely due to the rubber phase

but also due to polypropylene itself. At 100°C it is expected that degradation process occurs in both phases.

In comparison with some thermoplastic rubbers based on polyolefins (commercially known TPO), NR/PP blends studied here show reasonable initial properties (Figure 4.22) even though their thermal-degradative stability is lower than the same blends produced by MRPRA<sup>(150)</sup>. Based on this comparison, it is clear that NR/PP blends can be prepared by mixing in the various mixers and, of course, for commercial production a combination of Banbury (internal mixer) and extruder will be preferable, in terms of processing time required and dispersion of the blends obtained.

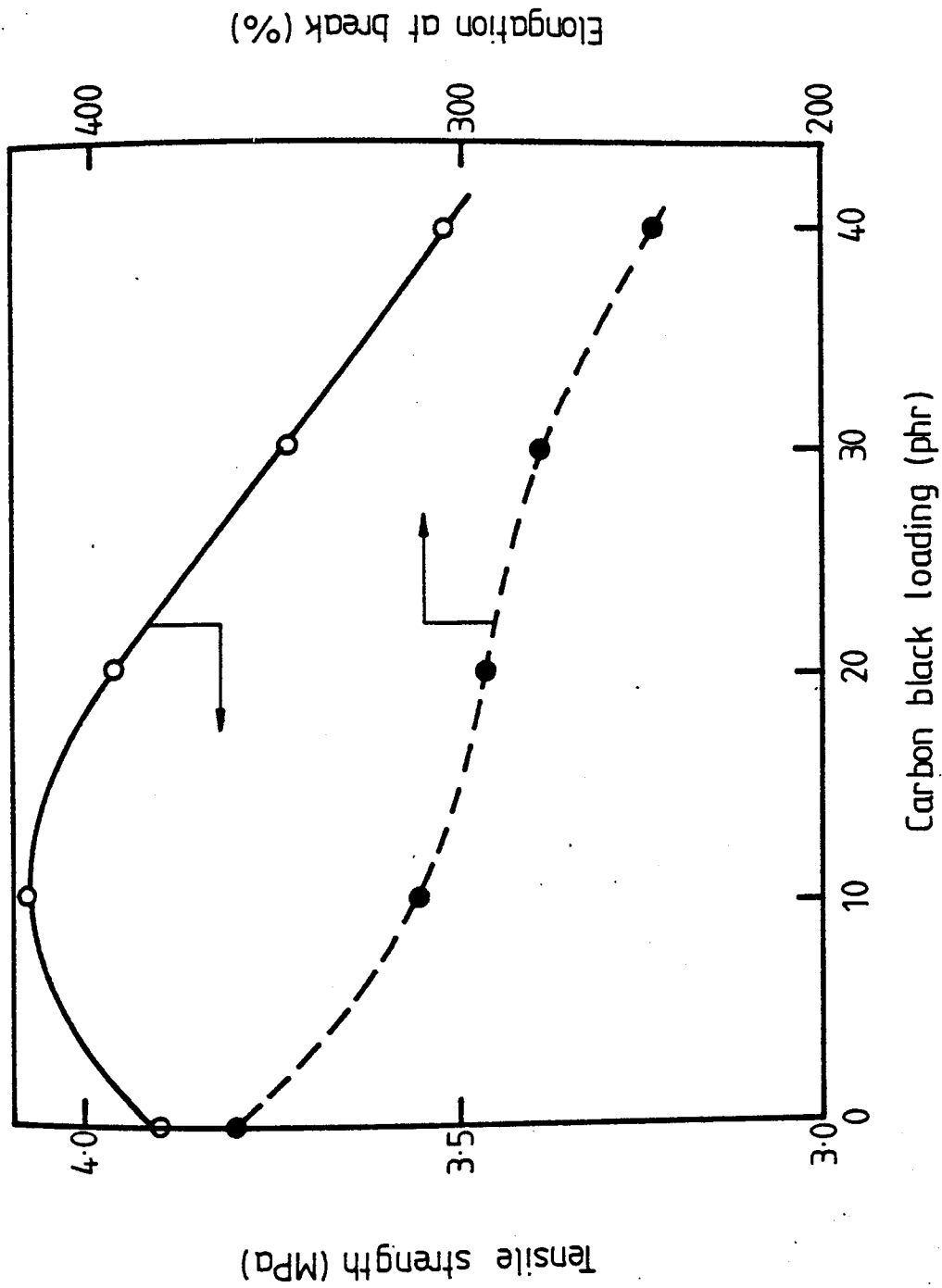

Figure 4.1 - Effect of varying concentration of carbon black on the tensile properties of NR/PP (60/40) blends, processed in a Brabender Torquerheometer at 160°C for 10 minutes.

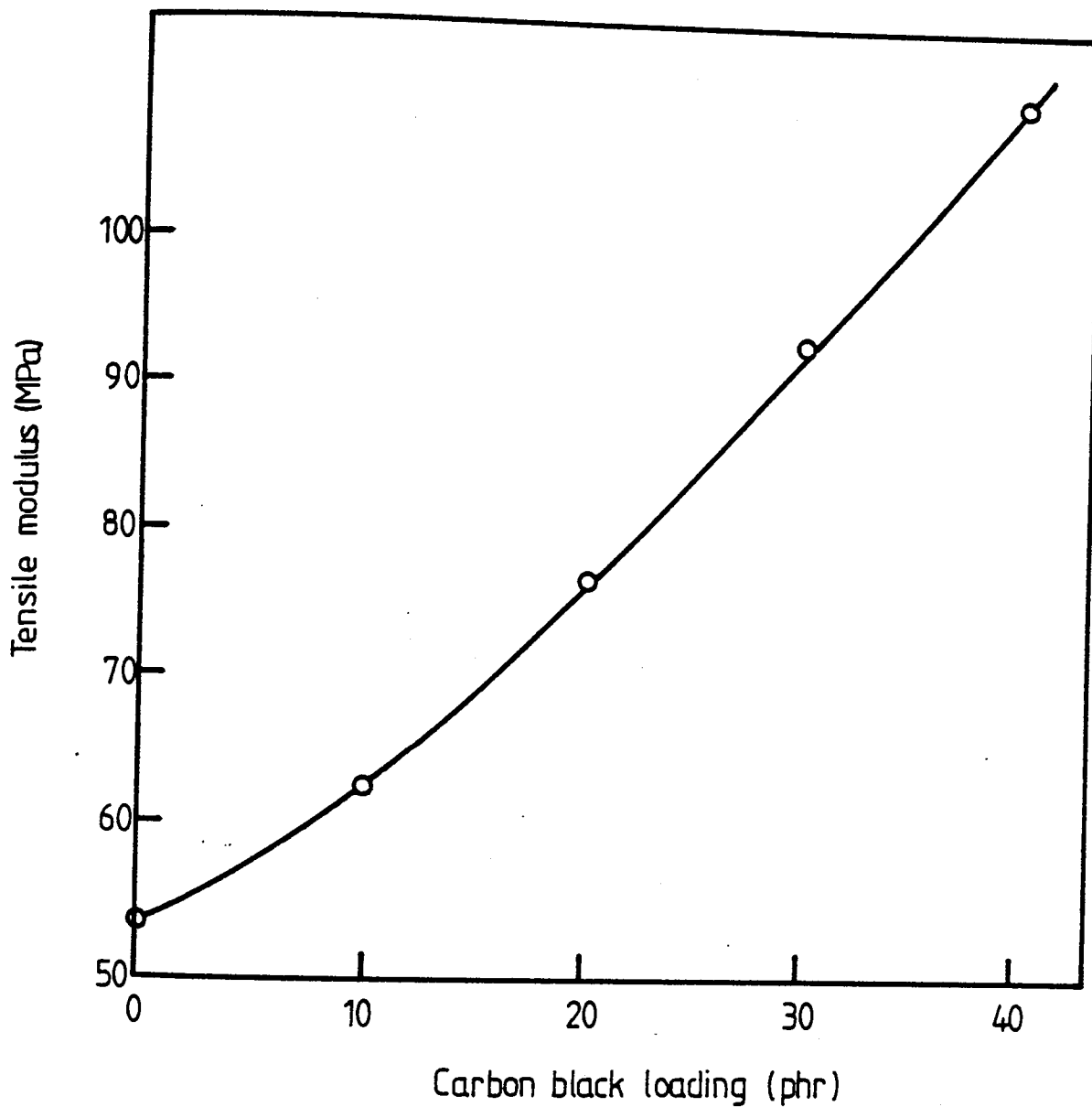

Figure 4.2 - Effect of varying concentration of carbon black on the tensile modulus of NR/PP (60/40) blends, processed in a Brabender Torquerheometer at 160°C for 10 minutes.

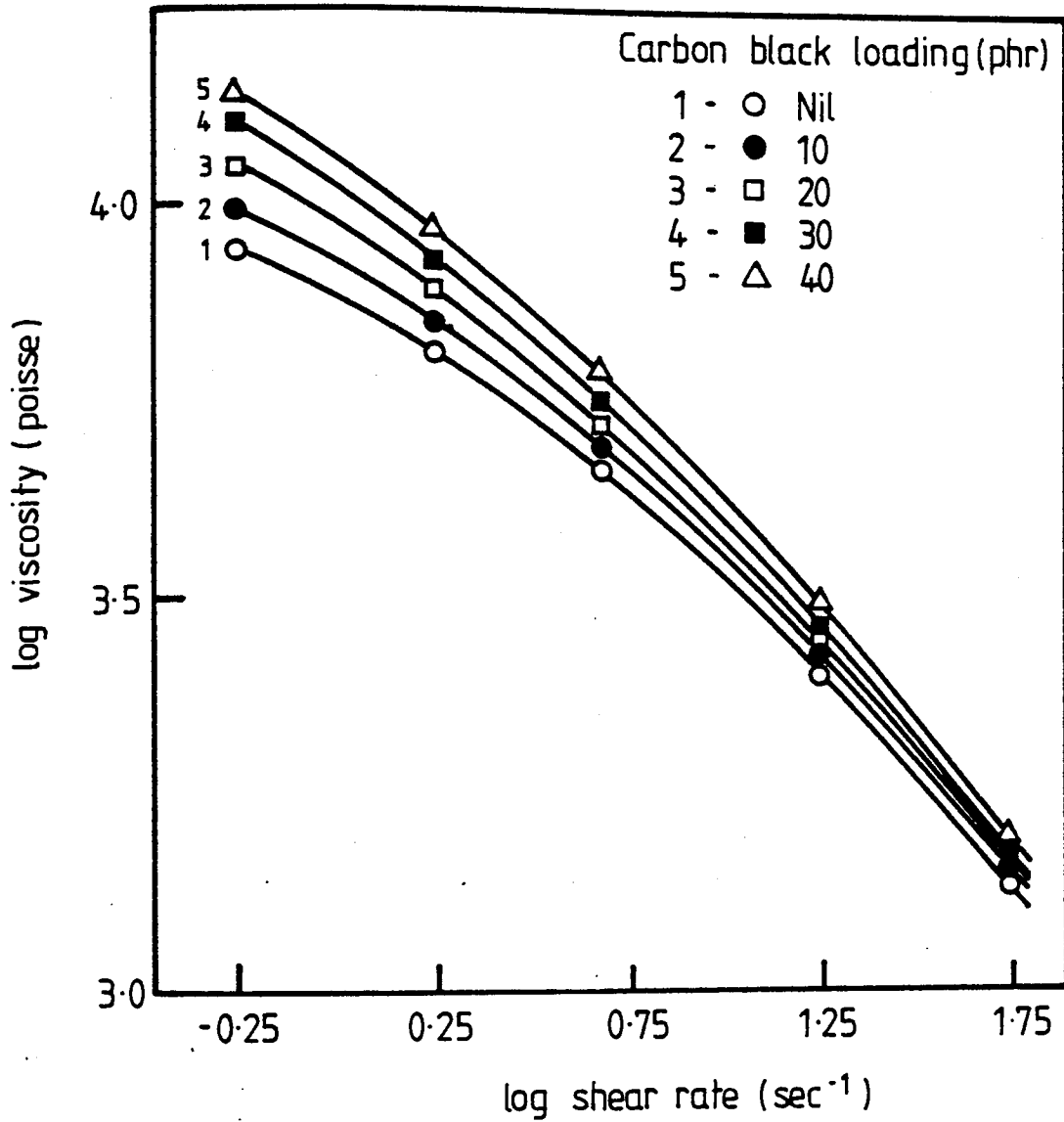
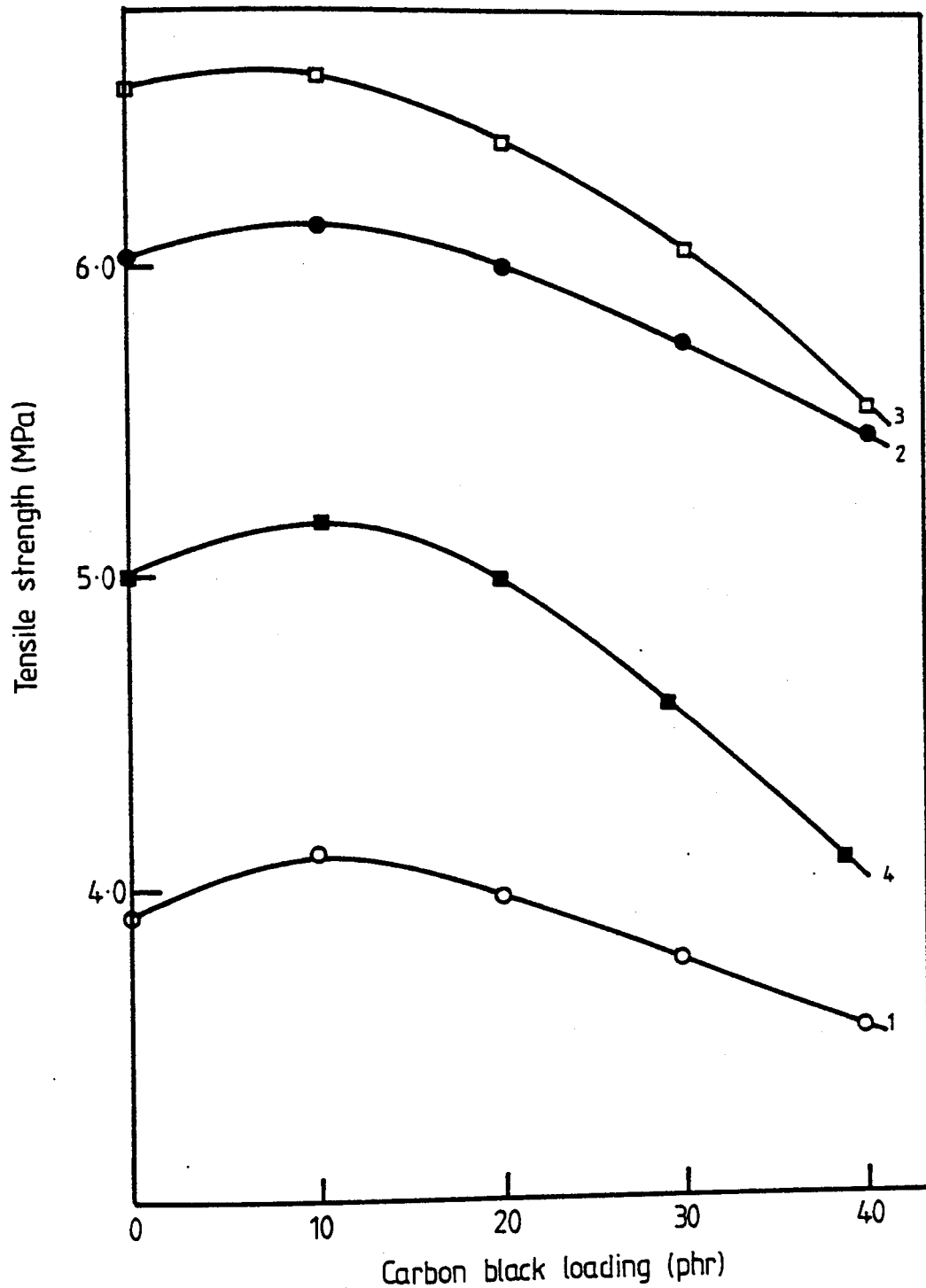

Figure 4.3 - Effect of varying concentration of carbon black on the melt rheology of NR/PP (60/40) blends processed in Brabender Torquerheometer at 160°C for 10 minutes.





Dicumyl peroxide conc. (phr)  
 1 - ○ Nil, 2 - ● 0.2, 3 - □ 0.4, 4 - ■ 0.6

Figure 4.4 - Effect of varying combination of carbon black and dicumyl peroxide on the tensile strength of NR/PP (60/40) blends, processed in a Brabender Torquerheometer at 160°C for 10 minutes.

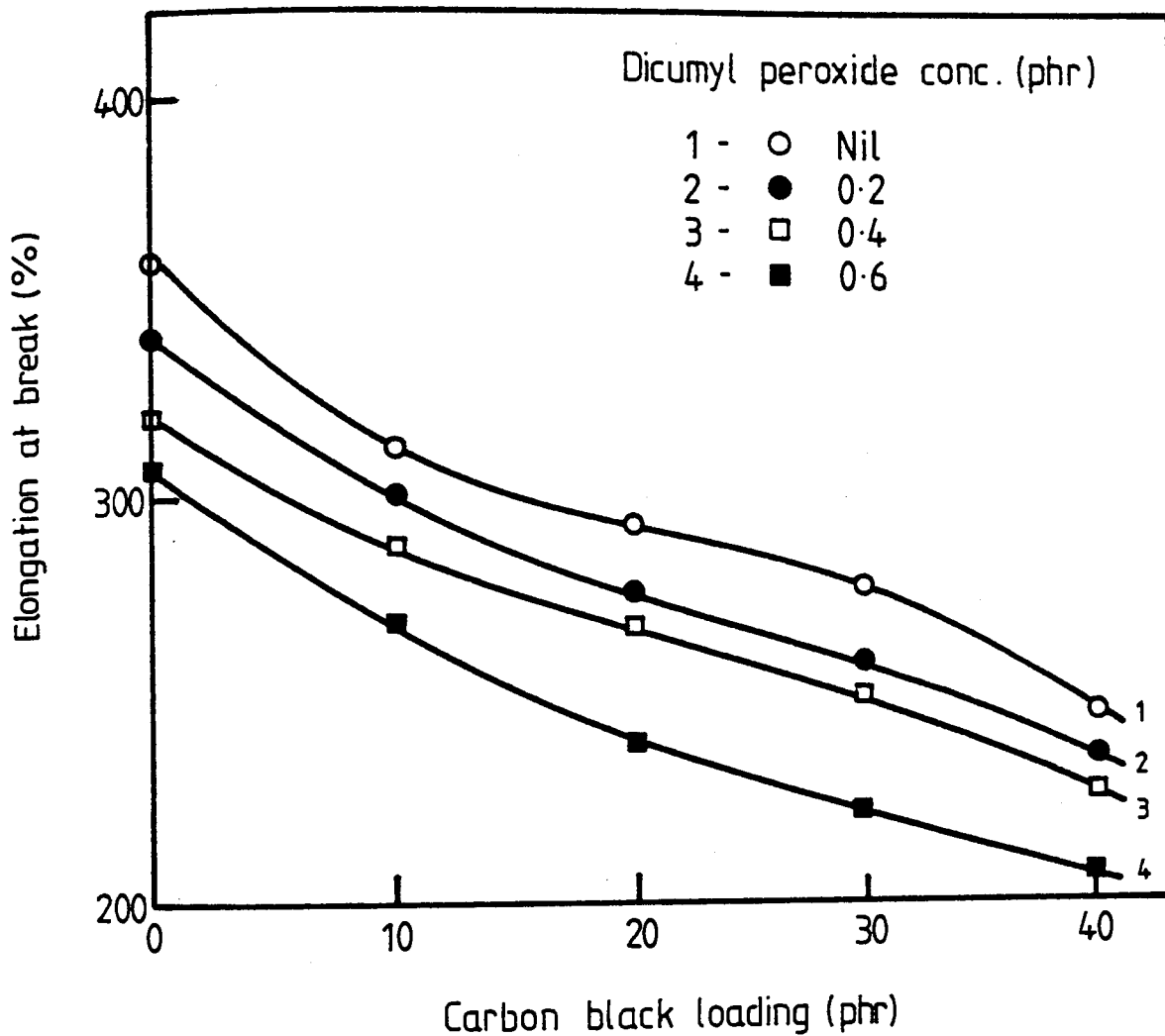

Figure 4.5 - Effect of varying combination of carbon black and dicumyl peroxide on the elongation at break of NR/PP (60/40) blends, processed in a Brabender Torquerheometer at 160°C for 10 minutes.

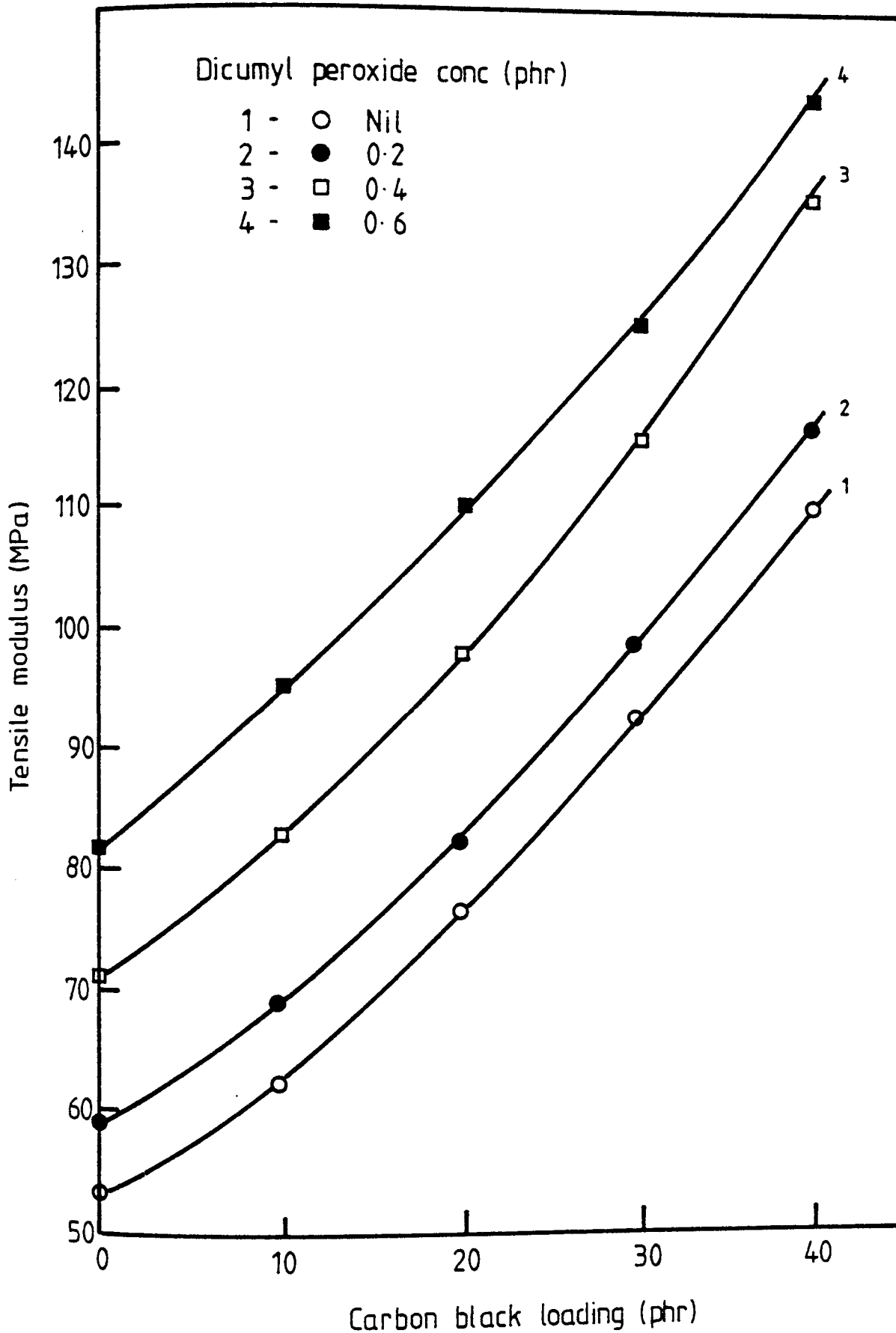

Figure 4.6 - Effect of varying combination of carbon black and dicumyl peroxide on the tensile modulus of NR/PP (60/40) blends, processed in a Brabender Torquerheometer at 160°C for 10 minutes.

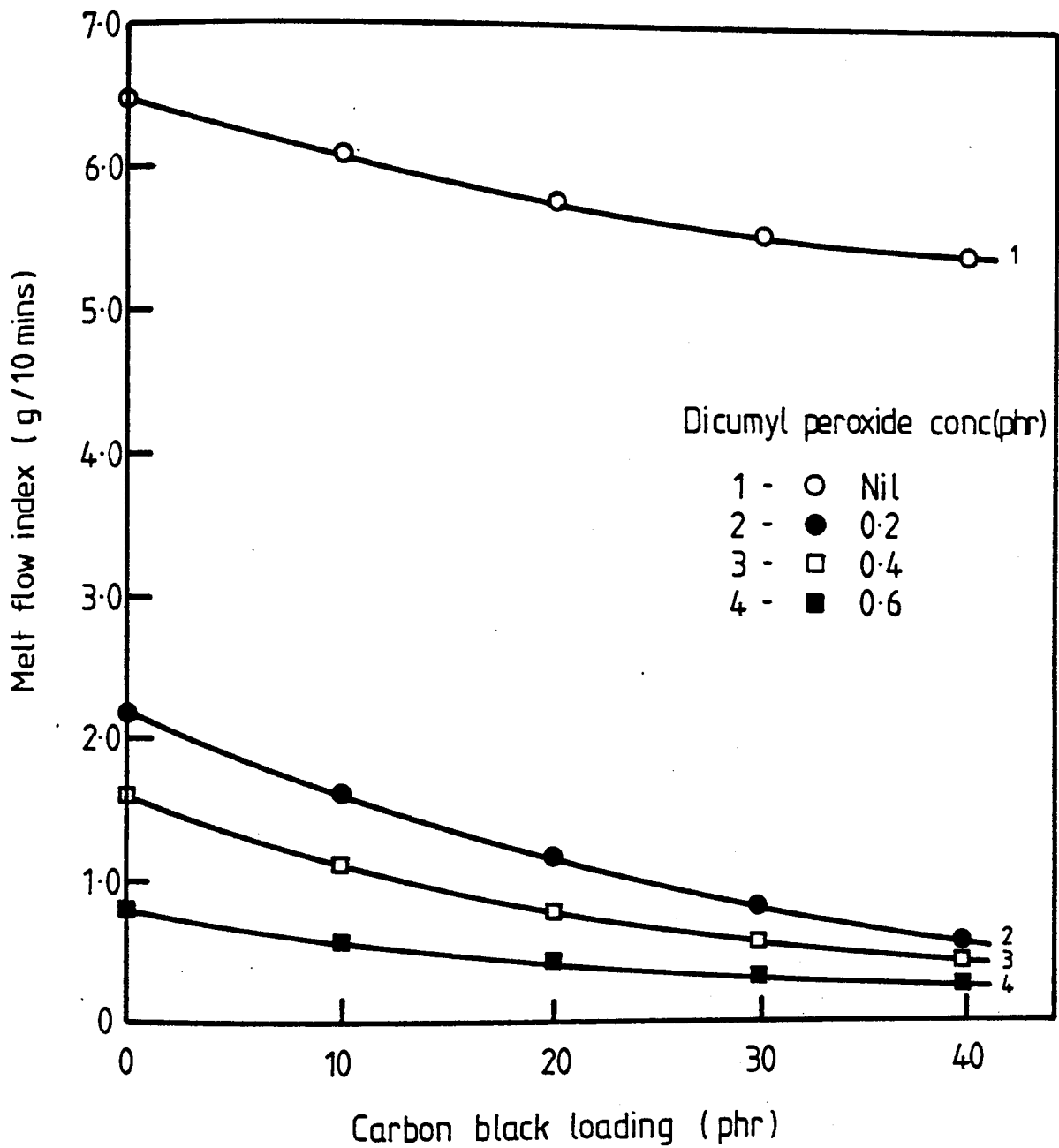

Figure 4.7 - Effect of varying combination of carbon black and dicumyl peroxide on the melt flow index of NR/PP (60/40) blends processed in a Brabender Torquerheometer at 160°C for 10 minutes.

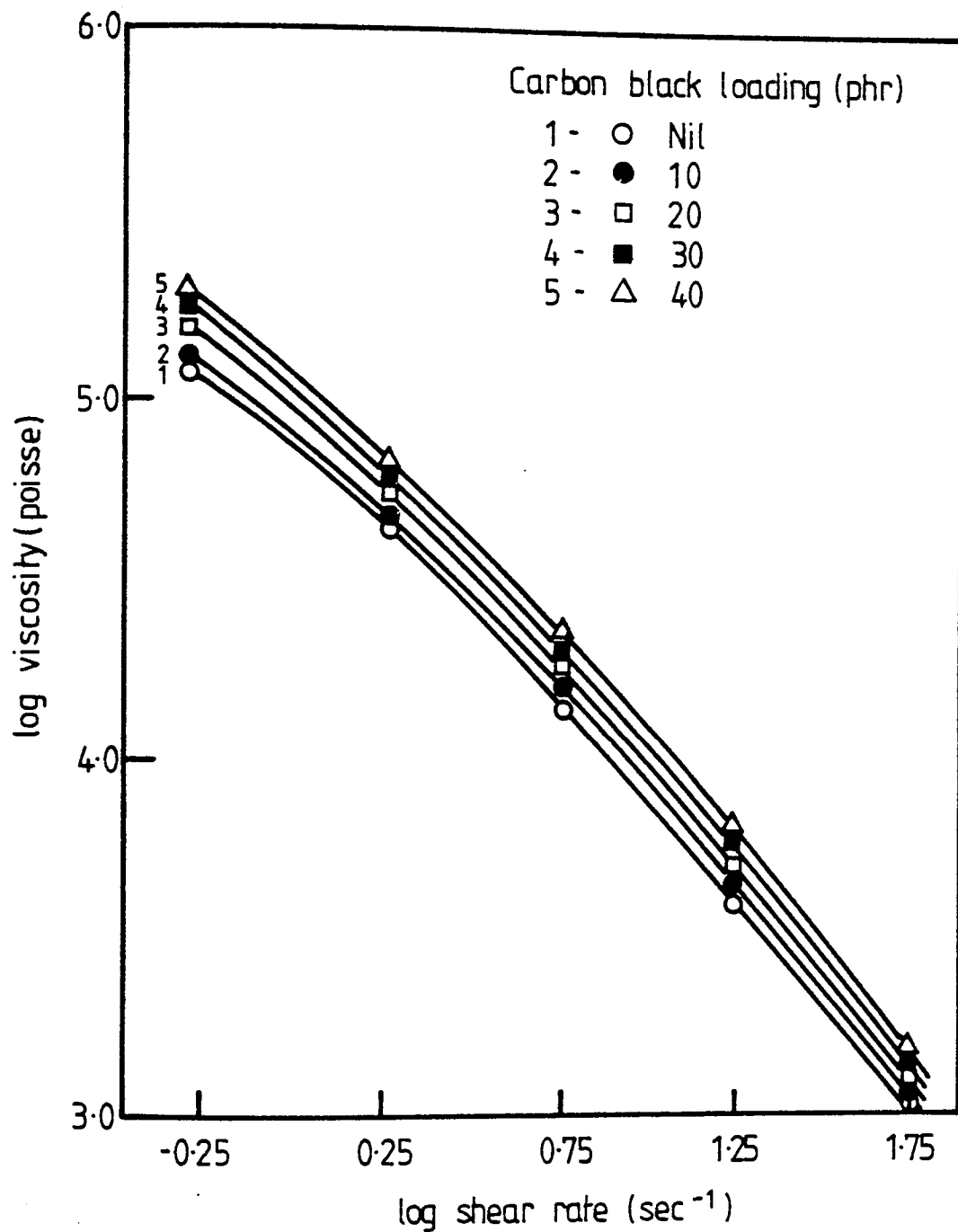

Figure 4.8 - Effect of varying carbon black loading on the melt rheology of NR/PP (60/40) blends containing 0.2 phr dicumyl peroxide processed in a Brabender Torquerheometer at 160°C for 10 minutes.

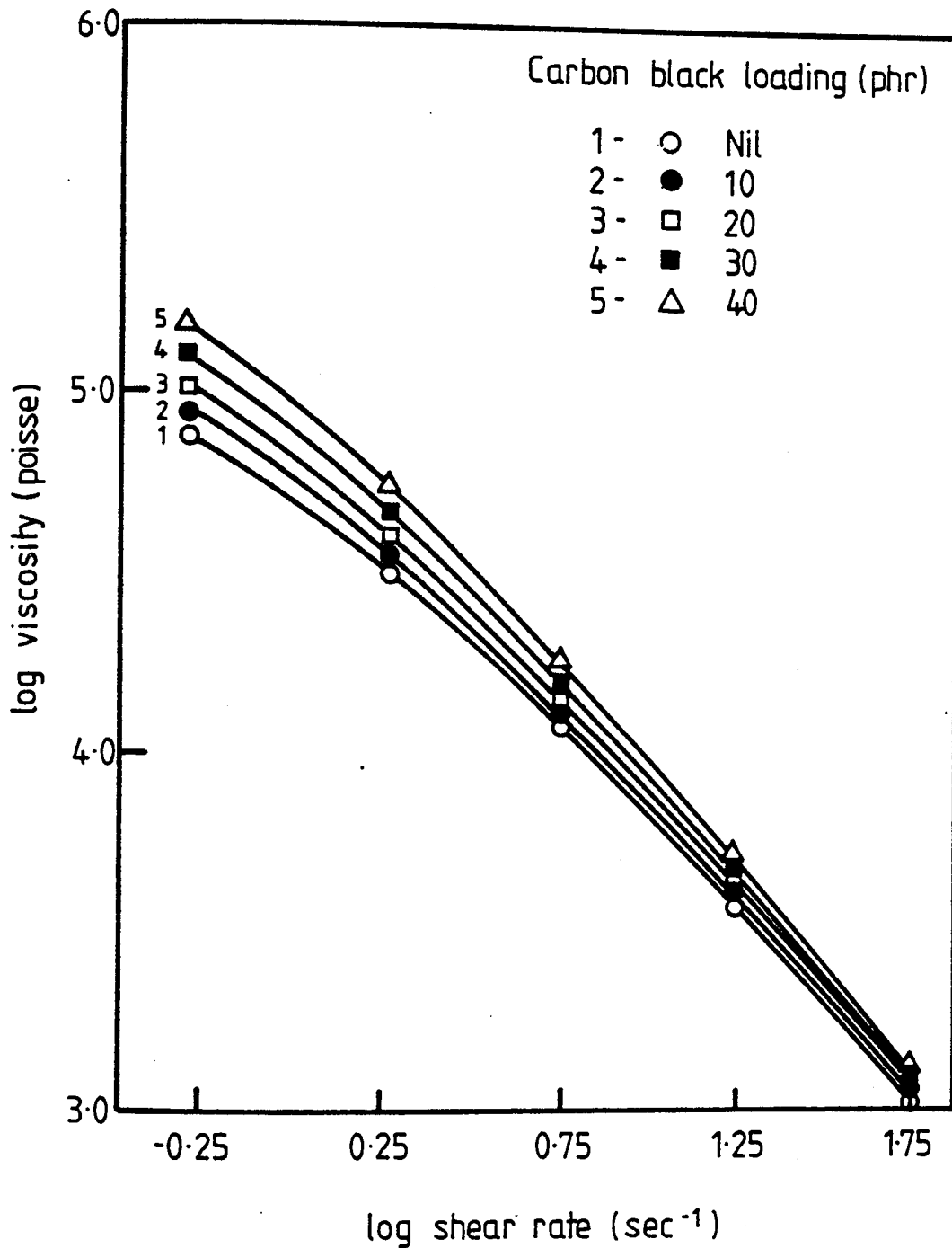

Figure 4.9 - Effect of varying carbon black loading on the melt rheology of NR/PP (60/40) blends containing 0.4 phr. dicumyl peroxide processed in a Brabender Torquerheometer at 160°C for 10 minutes.

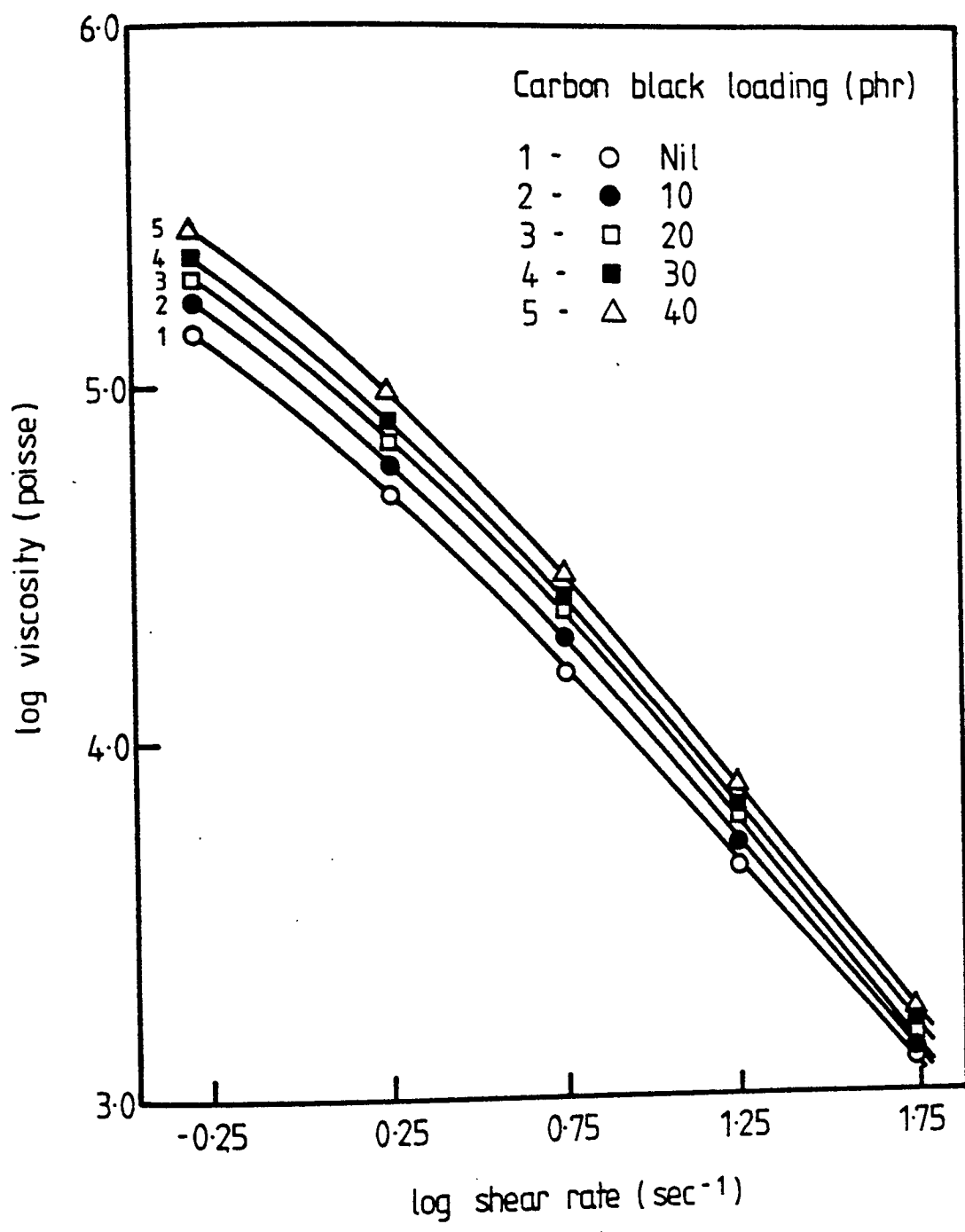
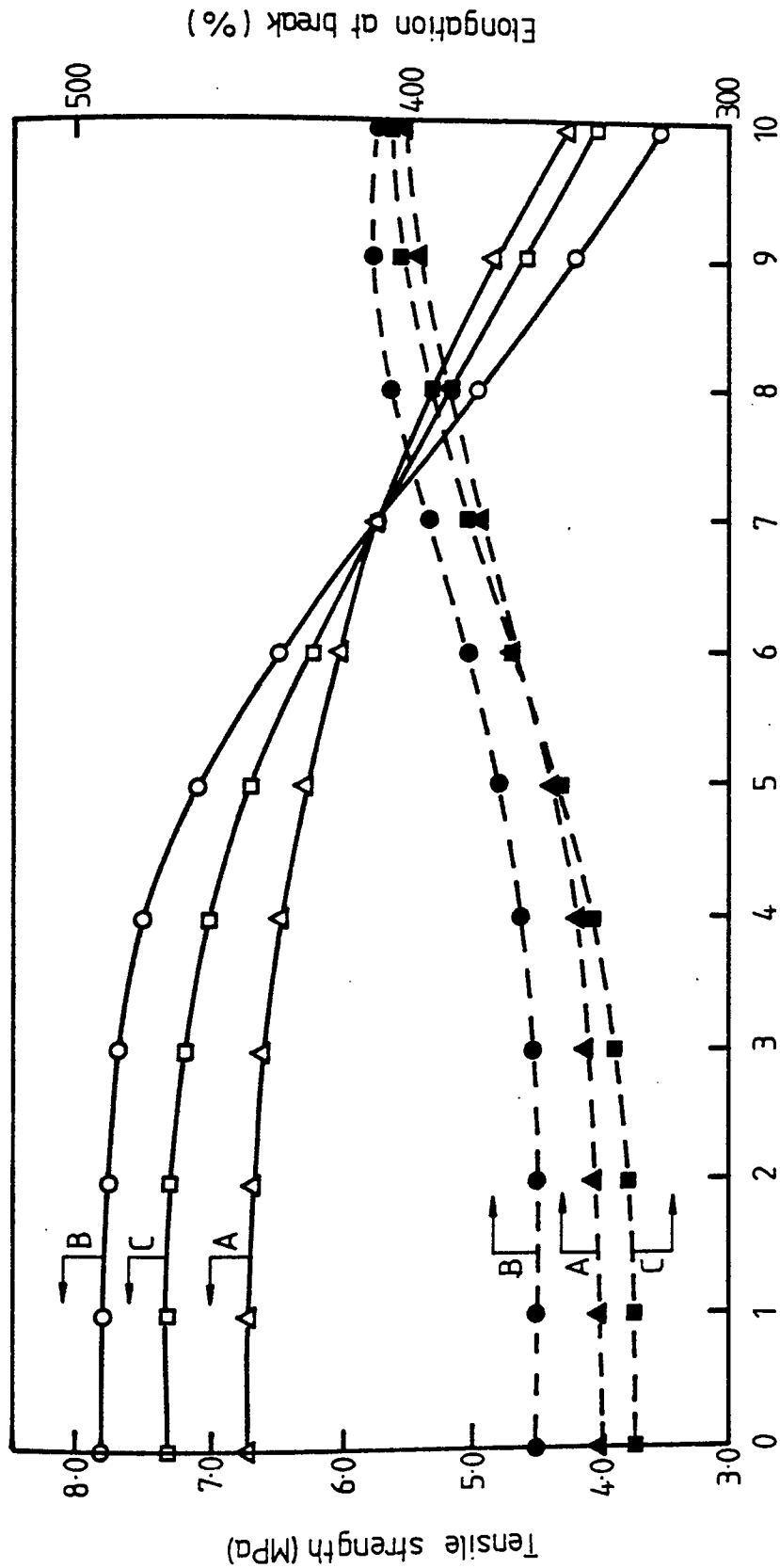

Figure 4.10 - Effect of varying carbon black loading on the melt rheology of NR/PP (60/40) blends containing 0.6 phr dicumyl peroxide processed in a Brabender Torquerheometer at 160°C for 10 minutes.



N° Re-compression moulding.

Figure 4.11 - Effect of re-compression moulding on the tensile properties of films of NR/PP (60/40) blends containing 0.3 phr. of dicumyl peroxide processed in Bra-bender (A); Busko Kneader (B) and Banbury (C) at 160°C.



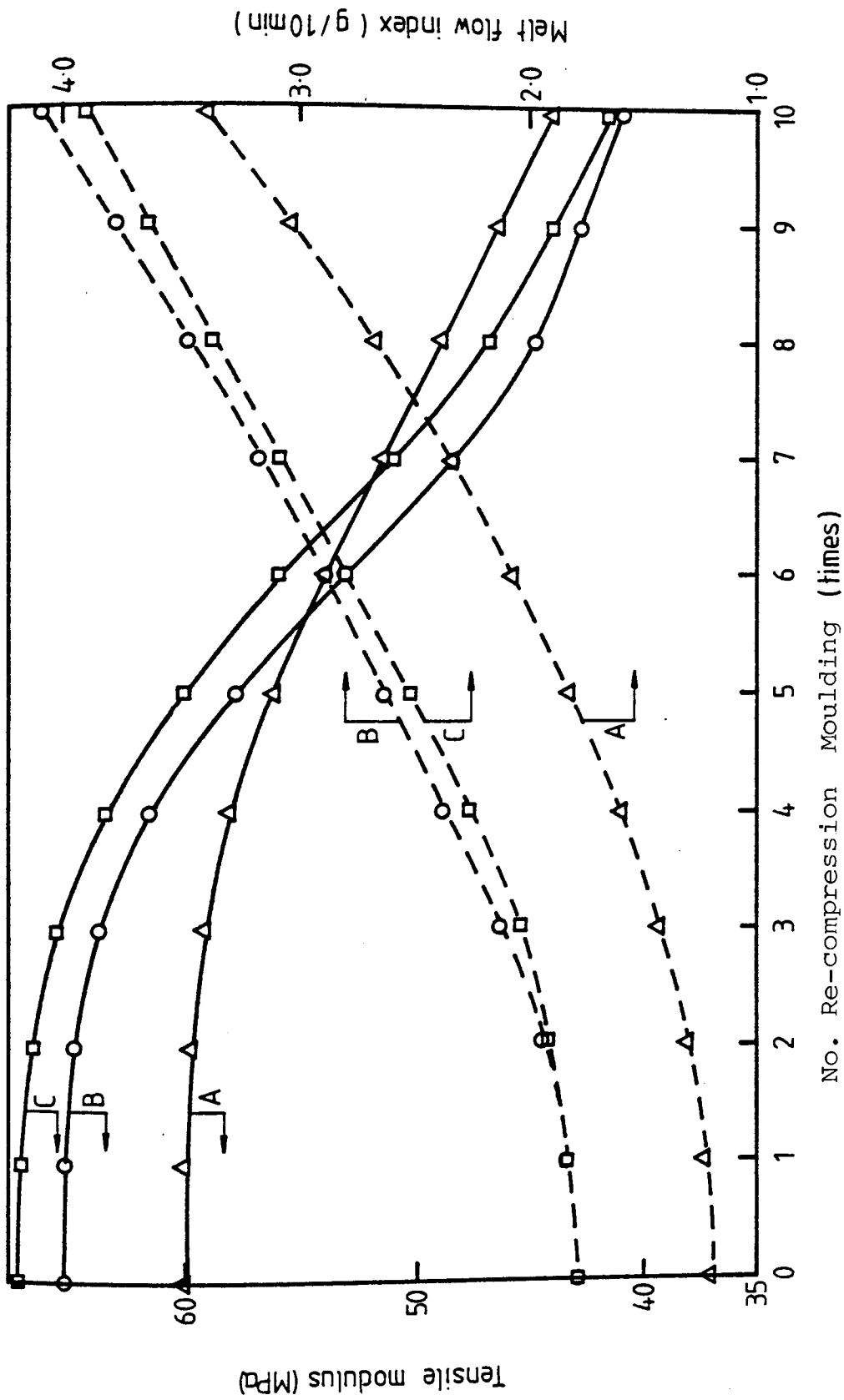

Figure 4.12 - Effect of re-compression moulding on the tensile modulus and melt flow index of NR/PP (60/40) blends containing 0.3 phr dicumyl peroxide processed in Brabender Torquerheometer (A), Busko Kneader (B) and Banbury (C) at 160°C.

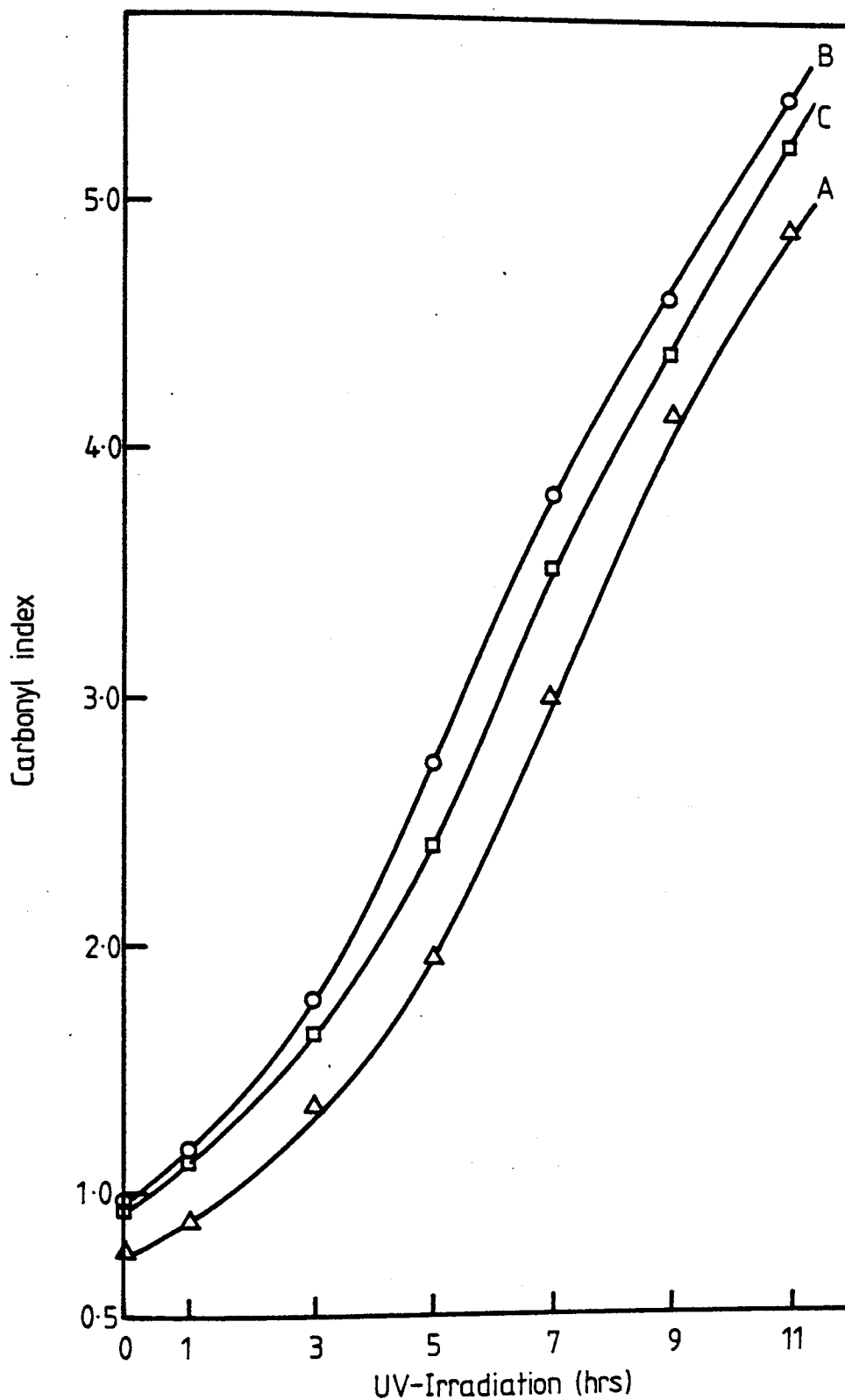

Figure 4.13 - Effect of uv-irradiation on the formation of carbonyl groups of the films of NR/PP (60/40) blends containing 0.3 phr dicumyl peroxide processed in Brabender (A), Busko Kneader (B) and Banbury (C) at 160°C.

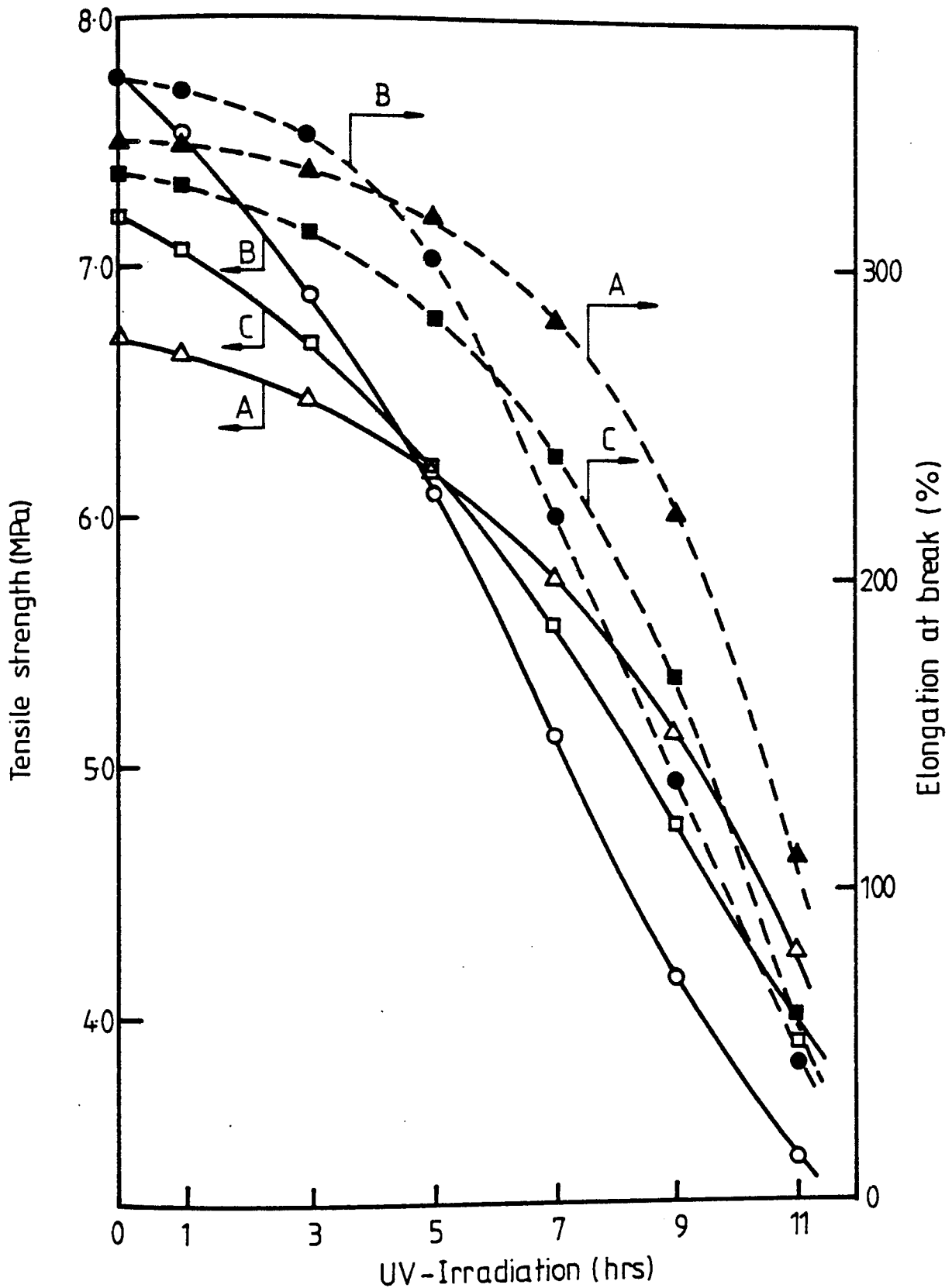

Figure 4.14 - Effect of uv-irradiation on the tensile properties of films of NR/PP (60/40) blends containing 0.3 phr. dicumyl peroxide processed in Bra-bender (A), Busko Kneader (B) and Banbury (C) at 160° C.

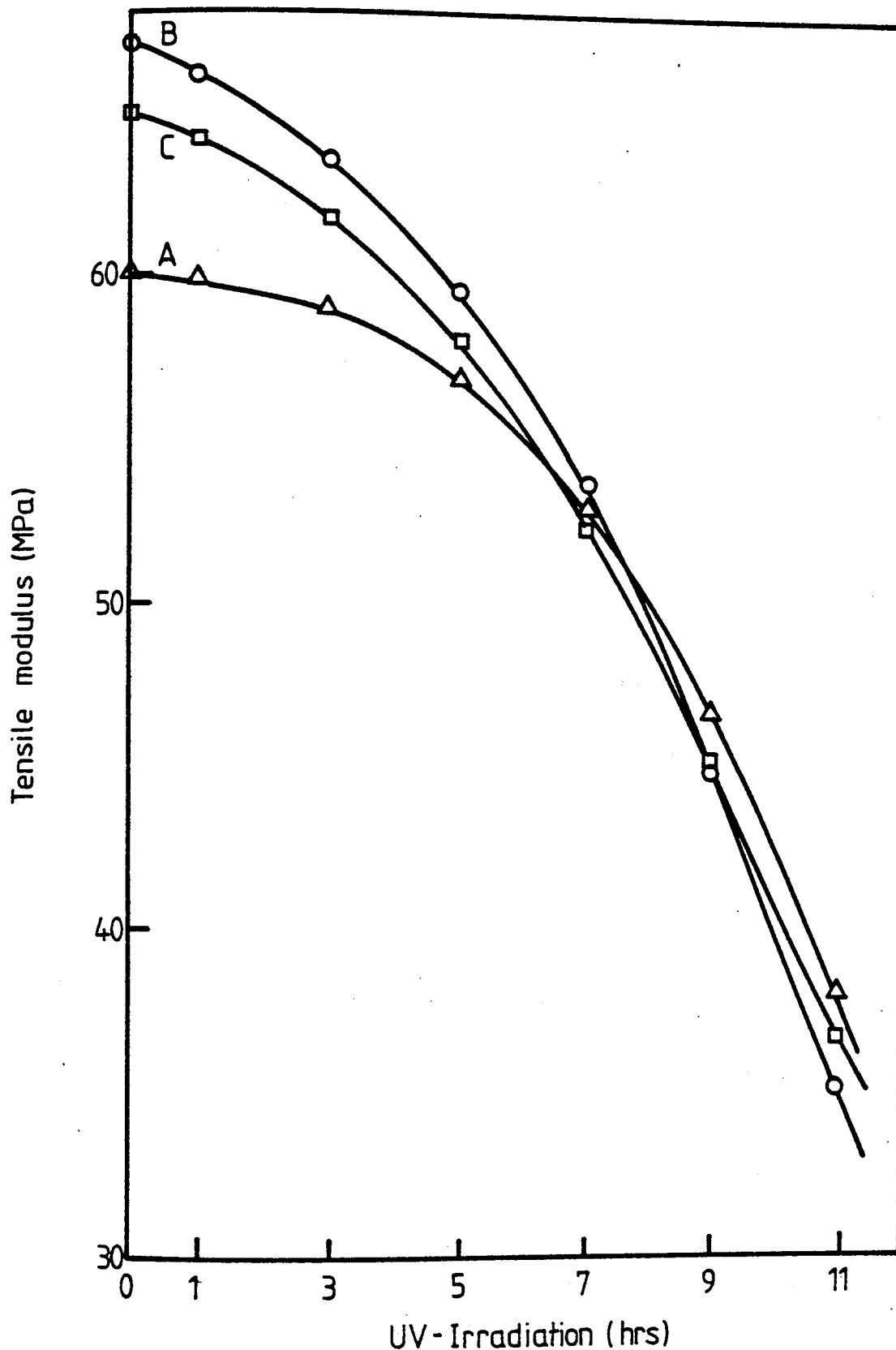

Figure 4.15 - Effect of uv-irradiation on the tensile modulus of films of NR/PP (60/40) blends containing 0.3 phr dicumyl peroxide processed in Brabender(A), Busko Kneader (B) and Banbury (C) at 160°C.

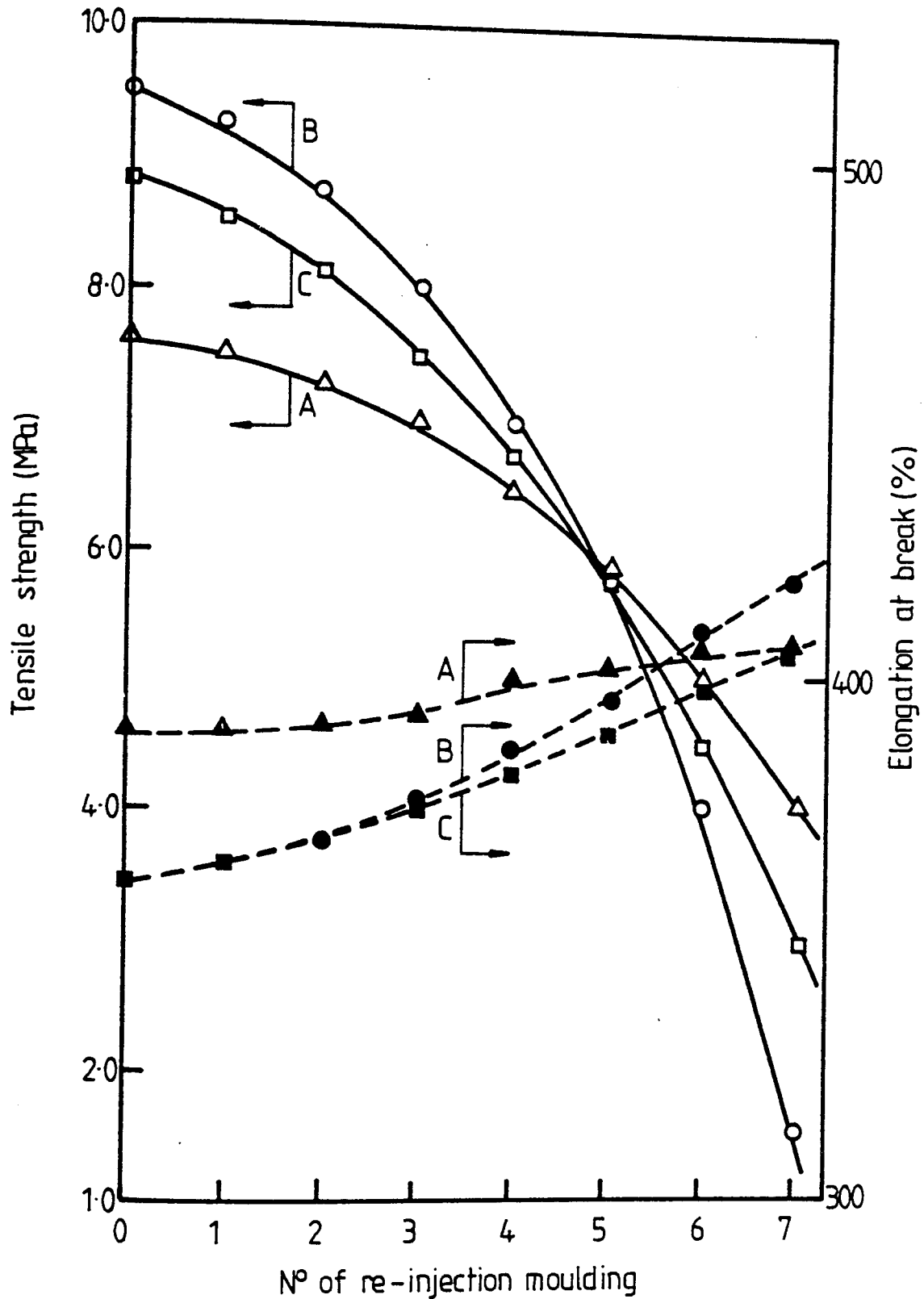

Figure 4.16 - Effect of re-injection moulding on the tensile properties of NR/PP blends (60/40) containing 0.3 phr dicumyl peroxide processed in Brabender (A), Busko Kneader (B) and Banbury (C) at 160°C.

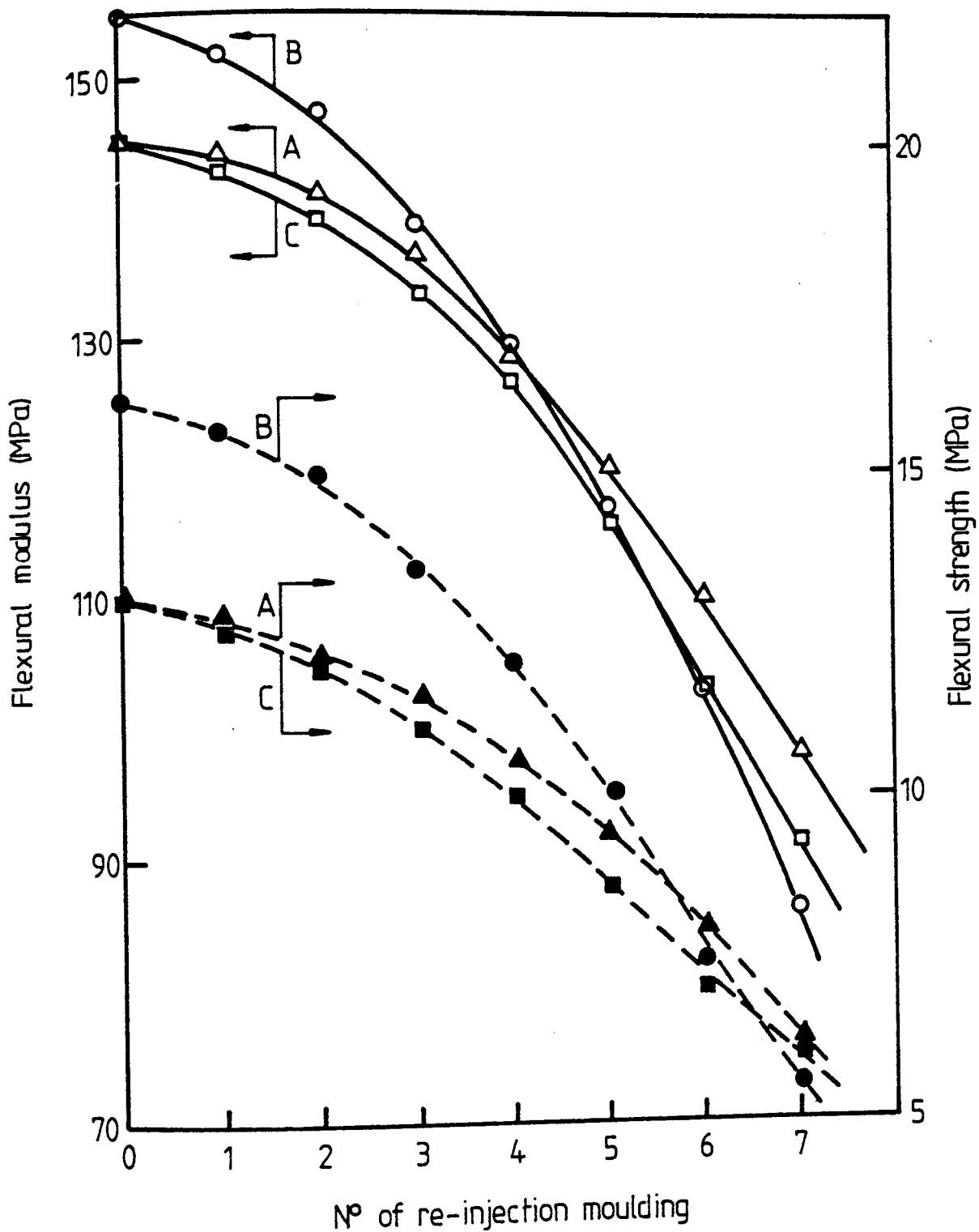

Figure 4.17 - Effect of re-injection moulding on the flexural properties of NR/PP blends (60/40) containing 0.3 phr dicumyl peroxide processed in Brabender (A), Busko Kneader (B) and Banbury (C) at 160°C.

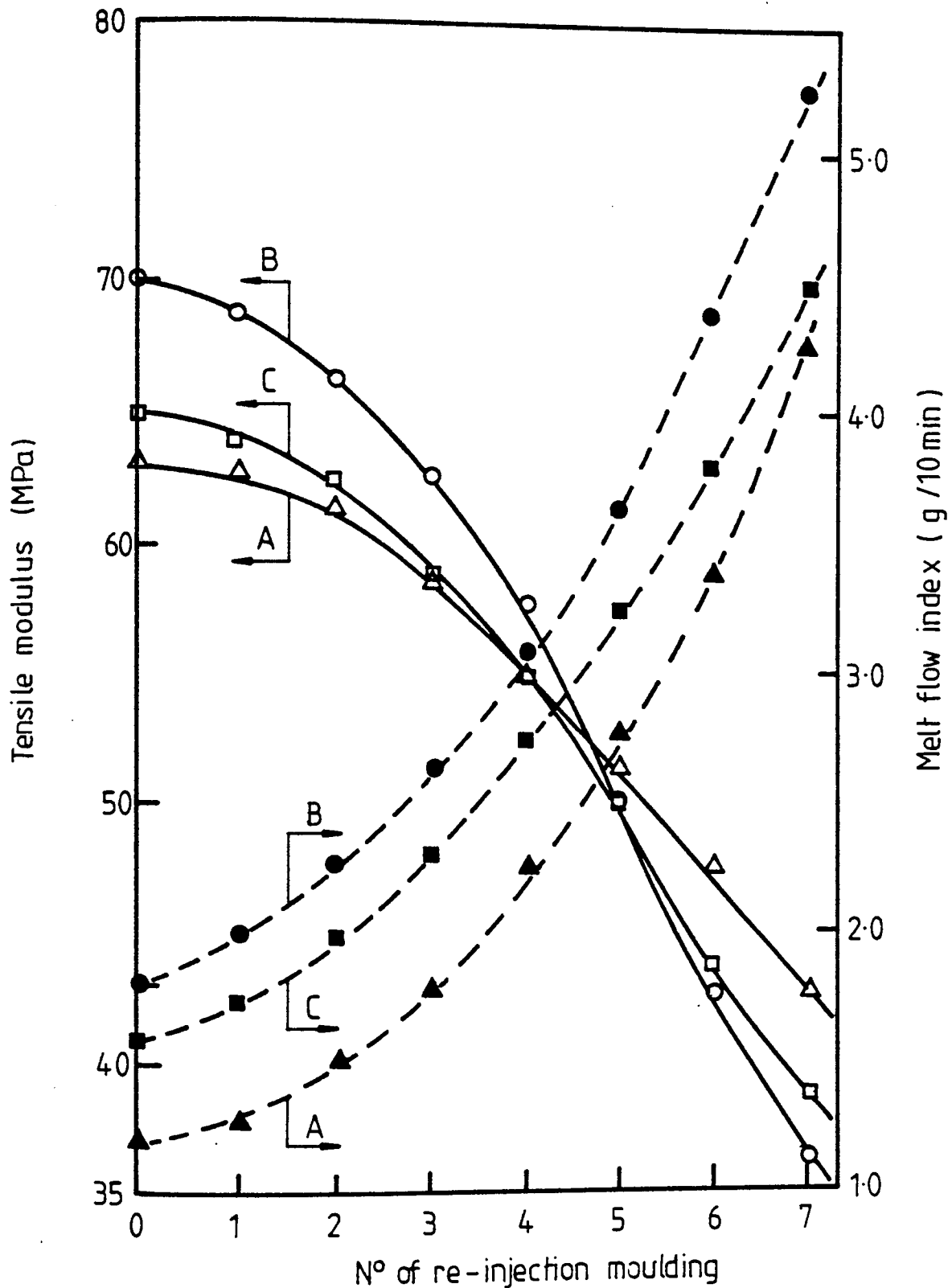

Figure 418 - Effect of re-injection moulding on the tensile modulus and melt flow index of NR/PP (60/40) blends containing 0.3phr dicumyl peroxide processed in Brabender (A), Busko Kneader (B) and Banbury (C) at 160°C.

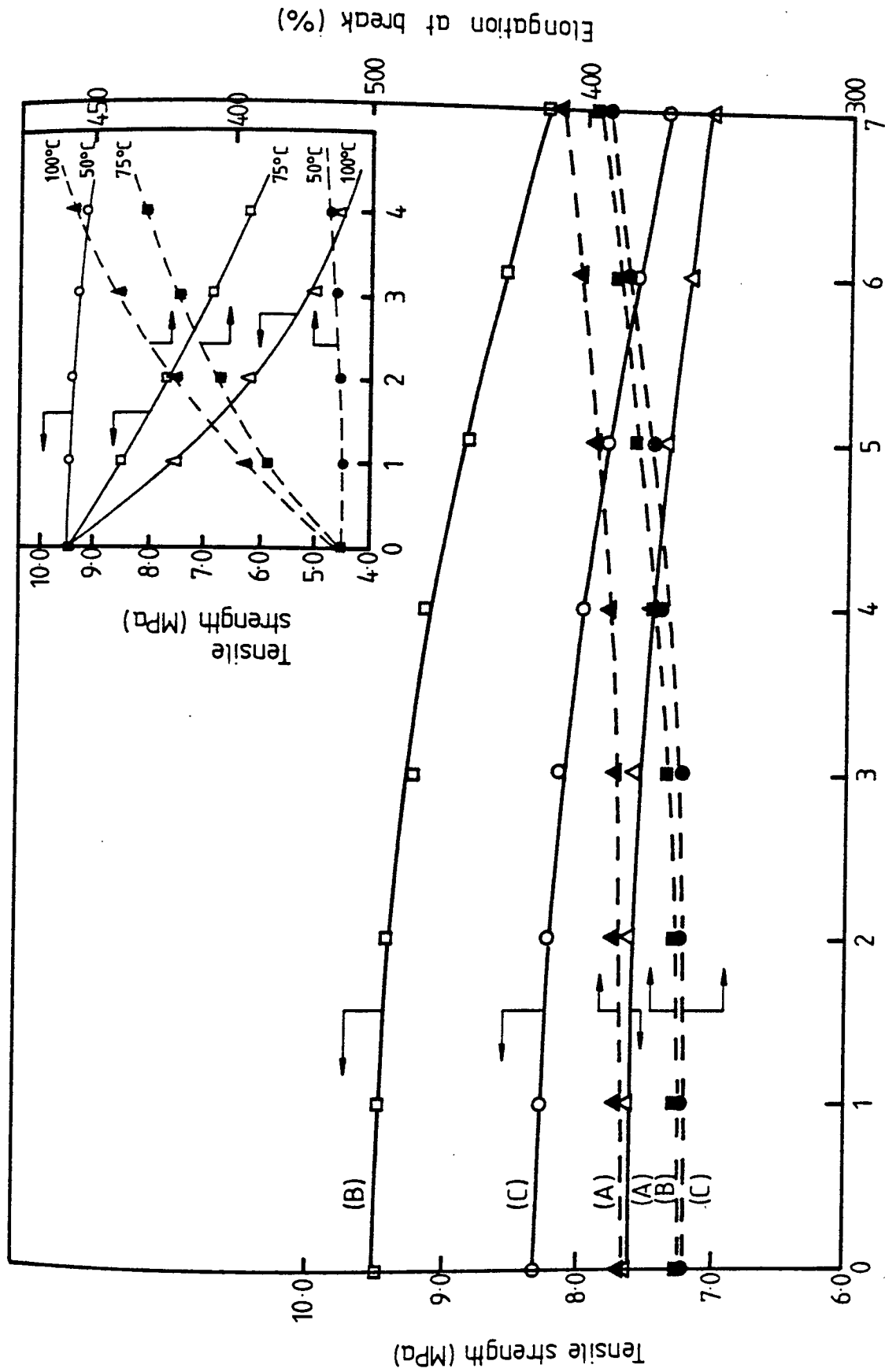

Figure 4.19 - Effect of oven-aging (50°C) on the tensile properties of NR/PP (60/40) blends containing 0.3 phr. dicumyl peroxide. Processed in the Brabender (A), Busko Kneader (B) and Banbury (C). (Inset compares the effect of different temperatures in the oven-aging on the tensile properties of Blends (B) processed under the same conditions (160°C, CM)



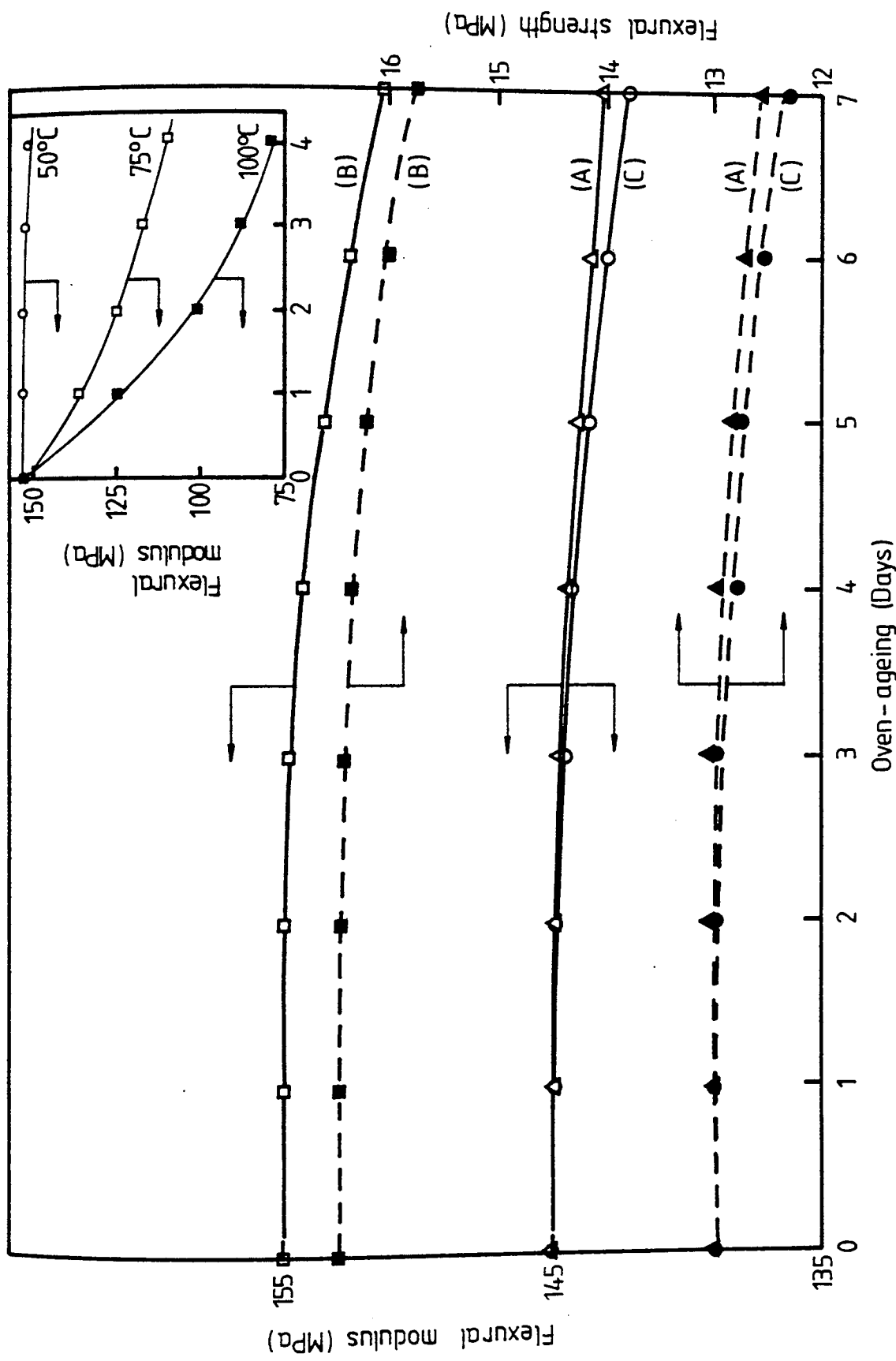

Figure 4.20 - Effect of oven-aging (50°C) on the flexural properties of NR/PP (60/40) blends containing 0.3 phr dicumyl peroxide processed in the Brabender (A), Busko Kneader (B), and Banbury (C). (Inset compares the effect of oven ageing at different temperatures on the flexural modulus of blends (B) processed under the same conditions) (160°C, CM).

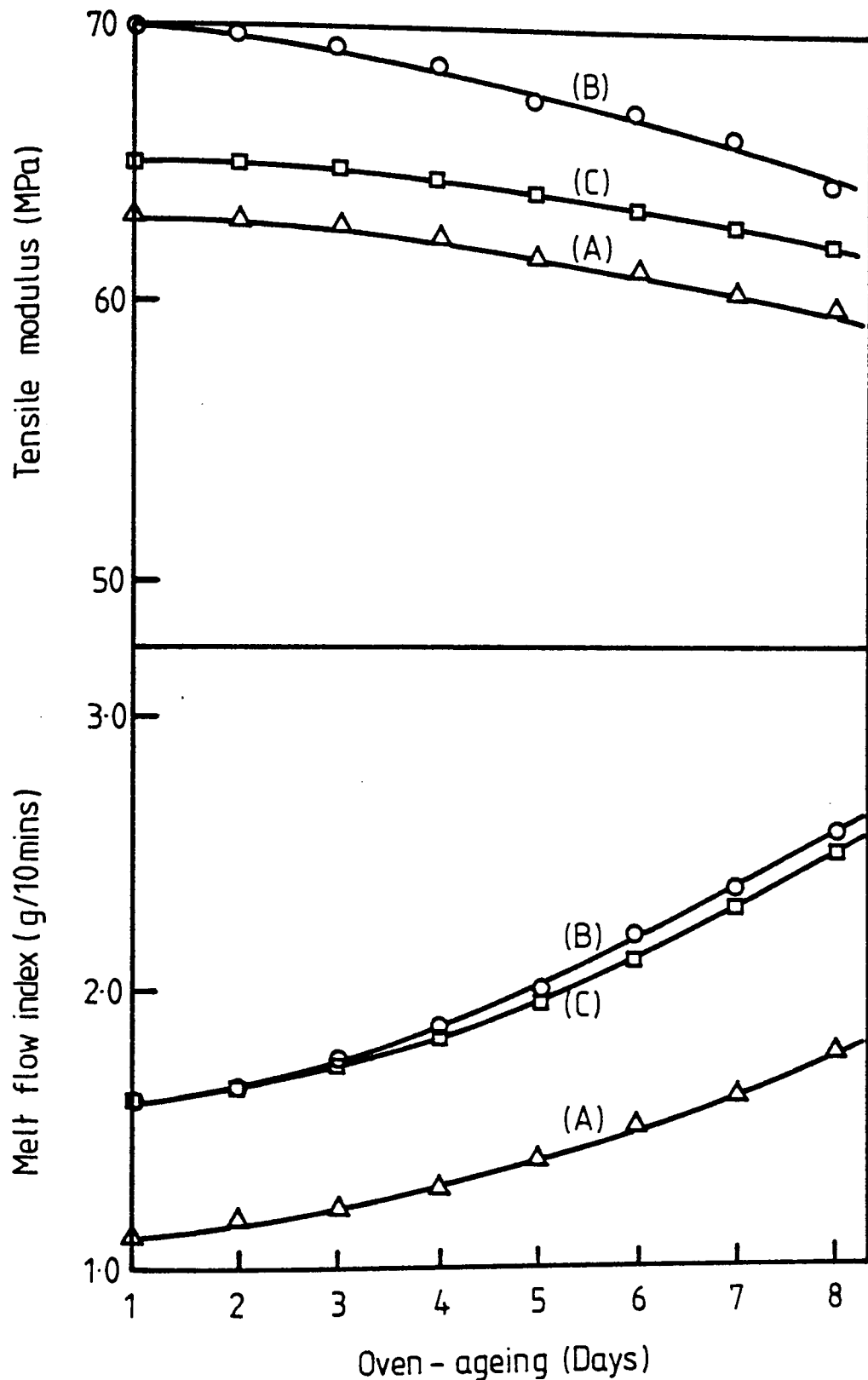

Figure 4.21 - Effect of oven-ageing ( $50^{\circ}\text{C}$ ) on the tensile modulus and melt flow index of NR/PP (60/40) blends containing 0.3 phr dicumyl peroxide processed in Brabender (A), Busko Kneader (B) and Banbury (C) at  $160^{\circ}\text{C}$ .

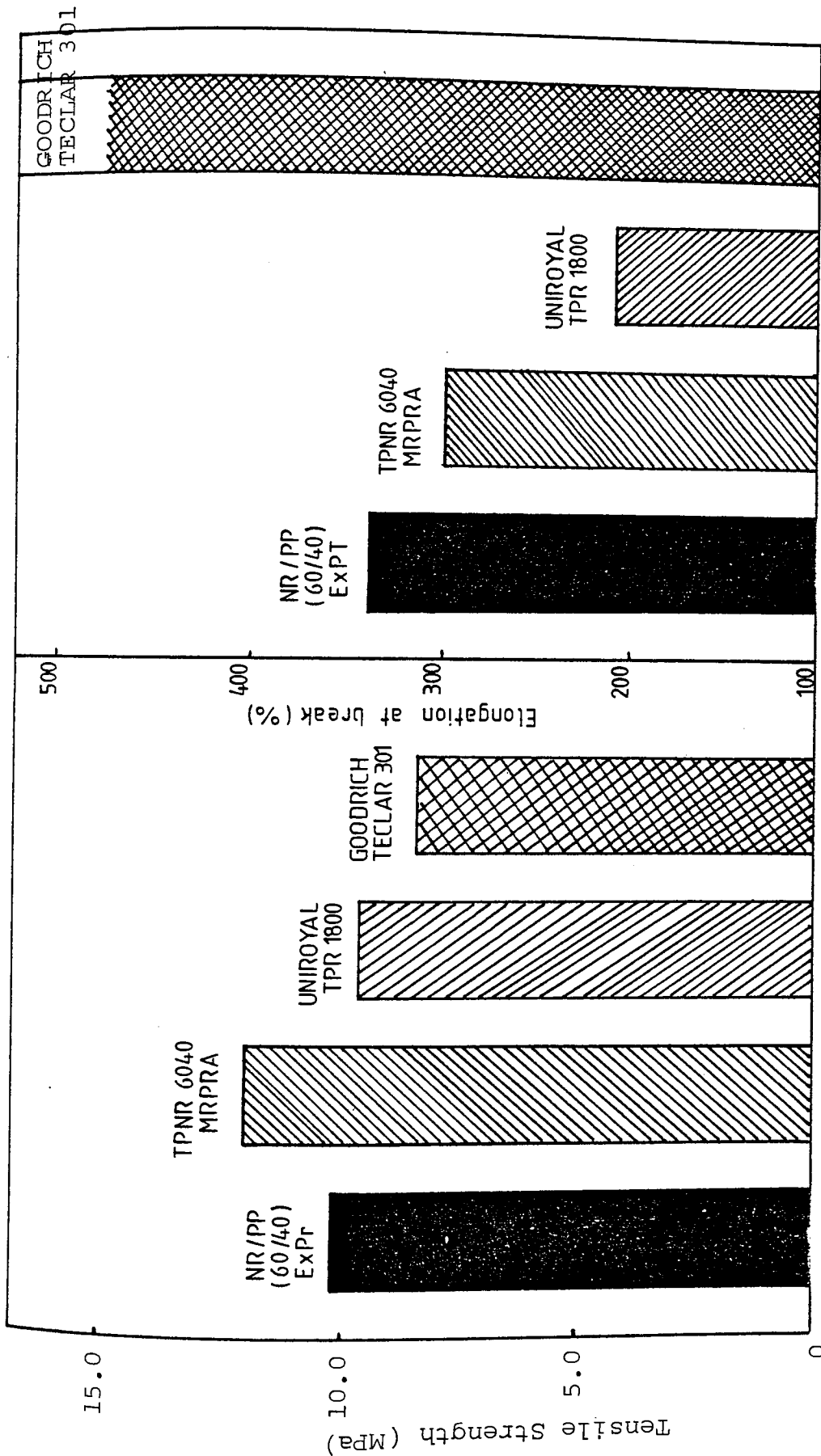

Figure 4.22 - Comparison in tensile properties of NR/PP blend from this work with some commercially available thermoplastic rubbers (based on polyolefin blend).

CHAPTER FIVE

EFFECT OF NR/PP COMPOSITION AS SOLID PHASE  
DISPERSANT ON THE PROPERTIES OF PP/PE BLENDS

## 5.1 Objective

Modification of binary blends of low density polyethylene with polypropylene by means of a solid phase dispersant (SPD) such as a block copolymer of ethylene-propylene terpolymer (EPDM) markedly improves mechanical properties of the blends, e.g., flexibility and impact strength<sup>(111,152)</sup> which, in turn, serves to increase the technological usefulness of such blends. The main function of a modifier as a third component i.e., a solid phase dispersant (SPD) is to increase the compatibility of the two incompatible components provided the modifier has a similar structure to one or both components of the blend<sup>(153)</sup>. In the case of EPDM, ethylene segments are compatible with the polyethylene part of the blend and propylene segments with the polypropylene part. A second role of SPD is to act as an impact modifier. This is related to the toughening mechanism offered by elastomers to glassy polymers. EPDM for example, in this case will act as the elastomer which becomes dispersed in the glassy matrix in the form of small particles. These particles act as stress concentrators<sup>(154)</sup>, hence initiate crack formation, however, they control the crack propagation by absorbing and dissipating the energy which otherwise will be available for the cracks.

In general a consequence of adding rubber to thermoplastic polyblends is that they become more susceptible to oxidation due to the presence of unsaturation in the rubber. Exposure to ultra violet light, therefore, causes deterioration

of some physical properties<sup>(155)</sup> leading to rapid embrittlement<sup>(156)</sup>. Similarly in PP/PE polyblends containing solid phase dispersant, the unsaturation in the rubber part of the SPD will sensitise photo-oxidation<sup>(109)</sup>.

This chapter is devoted to study of the use of NR/PP composition as a solid phase dispersant and impact modifier in PP/PE blends and its effect on the mechanical properties of this thermoplastic blend. Processing procedure in the preparation of PP/PE containing NR/PP composition is also studied. Photo-oxidative stability of PP/PE blends containing SPD's and effectiveness of some commercial stabilisers are investigated.

Typically, NR/PP composition (weight ratio 60/40) was processed in a Brabender Torque rheometer at 160°C for 10 minutes (Processing Mode A), with 0.3 phr dicumyl peroxide (see Chapter 3, Section 3.2). PP/PE blends (weight ratio 1:1) were prepared in a closed mixer of a Brabender Torque rheometer at 180°C for 5 minutes<sup>(152)</sup>. The amount of NR/PP composition and EPDM used as SPD were varied (ranging from 0 to 30 percent weight) (Diagrams 5.1 and 5.2). While for blends processed in a Busko Kneader (160°C), NR/PP composition was used as the only SPD and varied as for the blends processed in the Brabender Torque rheometer. Blends processed in the Brabender Torque rheometer were compression moulded to produce film having thickness of 0.15-0.20 mm, and the blends processed in the Busko Kneader were compression

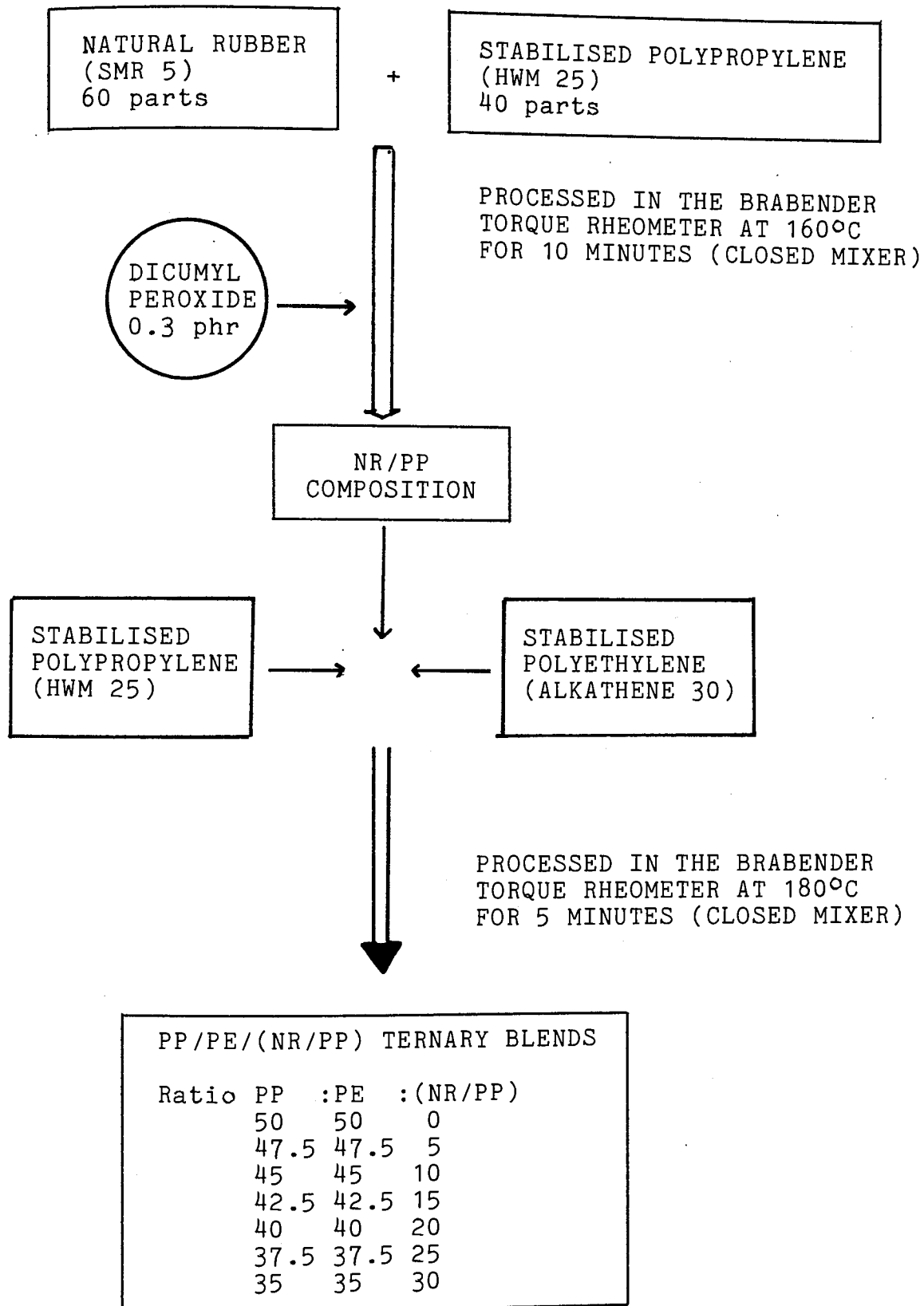

Diagram 5.1 Schematic operation of the preparation of PP/PE/(NR/PP) ternary blends

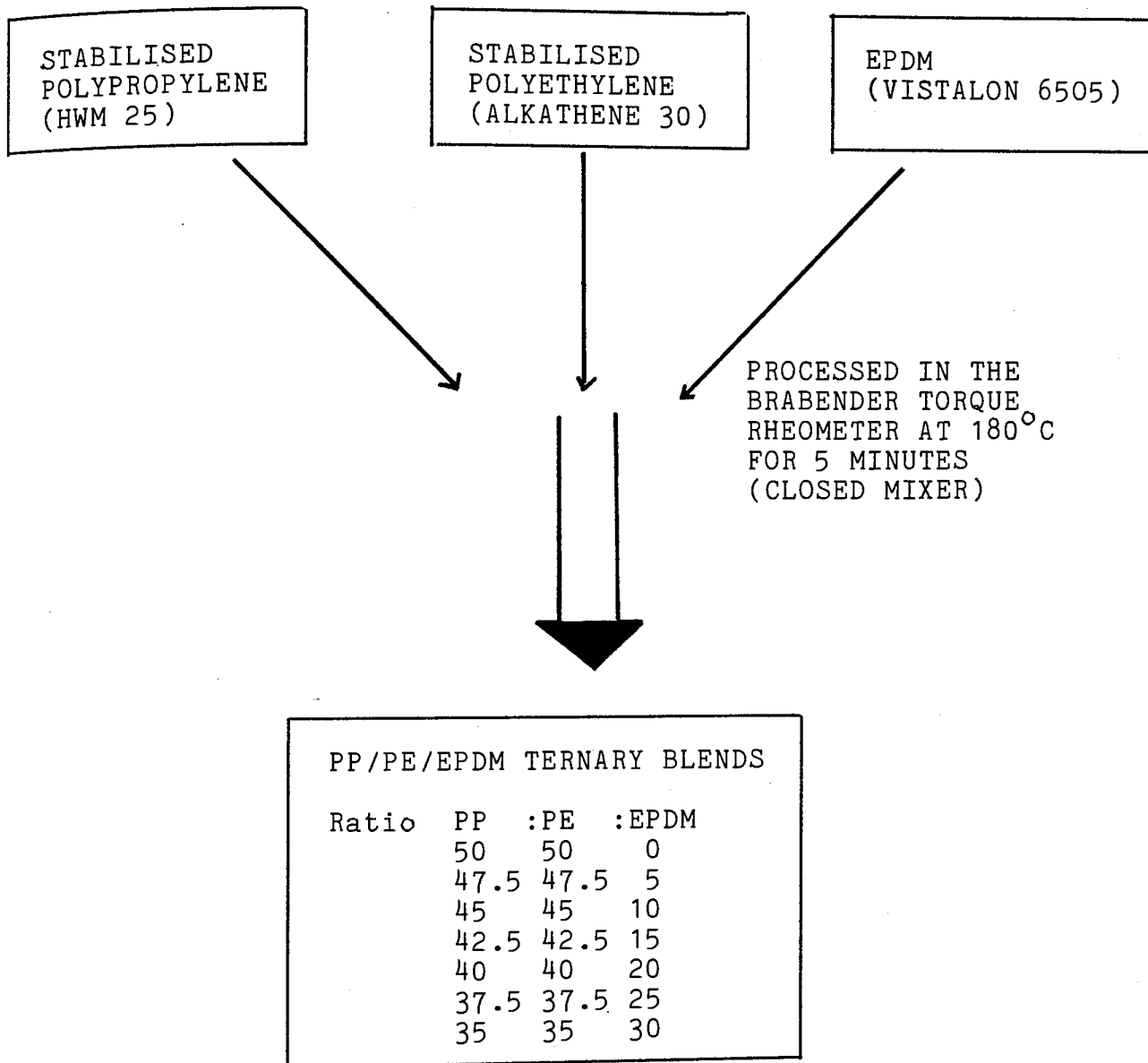

Diagram 5.2 Schematic operation of the preparation of PP/PE/EPDM ternary blends



moulded and injection moulded, in order to compare the effect of processing procedures (Busko Kneader and Brabender Torque rheometer) on the properties of the blends. Testing carried out was for tensile properties, impact resistance, light stability and dynamic mechanical properties measurements, and scanning electron microscopy for impact fractured samples.

In the investigation of the effect of some commercial stabilisers, the components of NR/PP composition were varied according to the following conditions:

Type A : Natural rubber (60 parts)

Polypropylene (40 parts), stabilised HWM 25

Type B : Natural rubber (60 parts)

Polypropylene (40 parts), unstabilised HF 18  
+ 0.2% Irganox 1076

Type C : Natural rubber (60 parts)

Polypropylene (40 parts), unstabilised HF 18  
+ 0.2% Irganox 1076 + 0.2% DLTP

Preparation of NR/PP compositions was carried out in the Processing Mode A (with 0.3 phr dicumyl peroxide, 160°C for 10 minutes). The final composition of the ternary blends PP/PE/SPD was at a weight ratio of 40/40/20.

Based on the types of PP, PE and SPD used, these ternary

blends were divided into four groups with different variation of stabiliser systems used (Table 5.1). The chemical structure of stabilisers used is shown in Appendix 2. Sample films were prepared by compression moulding, and were tested for tensile properties, impact resistance, melt flow index and photo-oxidation measured by build-up of carbonyl group (see Section 2.3.8).

## 5.2 Results and Discussions

### 5.2.1 Effect of Concentration of SPD on the Mechanical Properties of Ternary Blend PP/PE/SPD (40:40:20)

#### 5.2.1.1 Compression Moulded Samples

The effects of EPDM and NR/PP composition on the tensile properties of ternary blends PP/PE/SPD is shown in Figure 5.1. It is seen that the tensile strength of the blends decreases with increasing concentration of SPD and elongation at break increases commensurately. The magnitude of decrease in tensile strength of the blends containing EPDM is higher than the corresponding ones containing NR/PP composition. This must be attributed to the nature of SPD itself. The polypropylene component of the NR/PP composition contributes to increasing the strength of the ternary blends, while EPDM, which has a higher rubber content, will decrease it. This is also reflected in the elongation at break (increases with increasing concentration of SPD), and

PP/PE BLEND (40/40)	SOLID PHASE DISPERSANT		STABILISERS FOR PP/PE/SPD BLENDS (con : g/100 g of blend)
Group I	(1)NRPP type A	(2)EPDM	
PP: stabilised HWM 25	I.1.1	I.2.1	none
PE: unstabilised Alkathene 30	I.1.2	I.2.2	HOBP(0.2) + cyasorb(0.2)
	I.1.3	I.2.3	HOBP(0.2)
	I.1.4	I.2.4	Cyasorb(0.2)
	I.1.5	I.2.5	Ni BsDP(0.2)
	I.1.6	I.2.6	Tinuvin 770(0.2)
Group II	(1)NRPP type A	(2)type B	(3)type C
PP: unstabilised Prophathene HF 18	II.1.1	II.2.1	II.3.1
	II.1.2	II.2.2	II.3.2
PE: unstabilised Alkathene	II.1.3	II.2.3	II.3.3
	II.1.4	II.2.4	II.3.4
	II.1.5	II.2.5	II.3.5
	II.1.6	II.2.6	II.3.6
	II.1.7	II.2.7	II.3.7
	II.1.8	II.2.8	II.3.8
	II.1.9	II.2.9	II.3.9
	II.1.10	II.2.10	-
	II.1.11	II.2.11	-
	II.1.12	II.2.12	-
	II.1.13	II.2.13	-
		(Diagram 5.5)	(Diagram 5.6)
		(Diagram 5.7)	(Diagram 5.7)
			None
			DLTP(0.1)+HOBP(0.2)+Cyasorb(0.2)
			DLTP(0.2)+HOBP(0.2)+Cyasorb(0.2)
			Irgamox(0.1)+HOBP(0.2)+Cyasorb(0.2)
			Irgamox(0.2)+HOBP(0.2)+Cyasorb(0.2)
			Irgamox(0.2)+HOBP(0.2)
			Irgamox(0.2)+Cyasorb(0.2)
			Irgamox(0.2)+Tinuvin 770(0.2)
			Irgamox(0.2)+NiBsDP(0.2)
			NiBsDP(0.1)+DBDS(0.1) +HOBP(0.1)
			NiBsDP(0.1)+DBDS(0.05)+HOBP(0.1)
			NiBsDp(0.1)+DBDS(0.1)+HOBP(0.2)+TBH(0.05)
			NiBsDP(0.1)+DBDS(0.1)+HOBP(0.2)+Di cup(0.05)

Table 5.1 Experimental scheme in the stabilisation of PP/PE/SPD (40:40:20) blends.

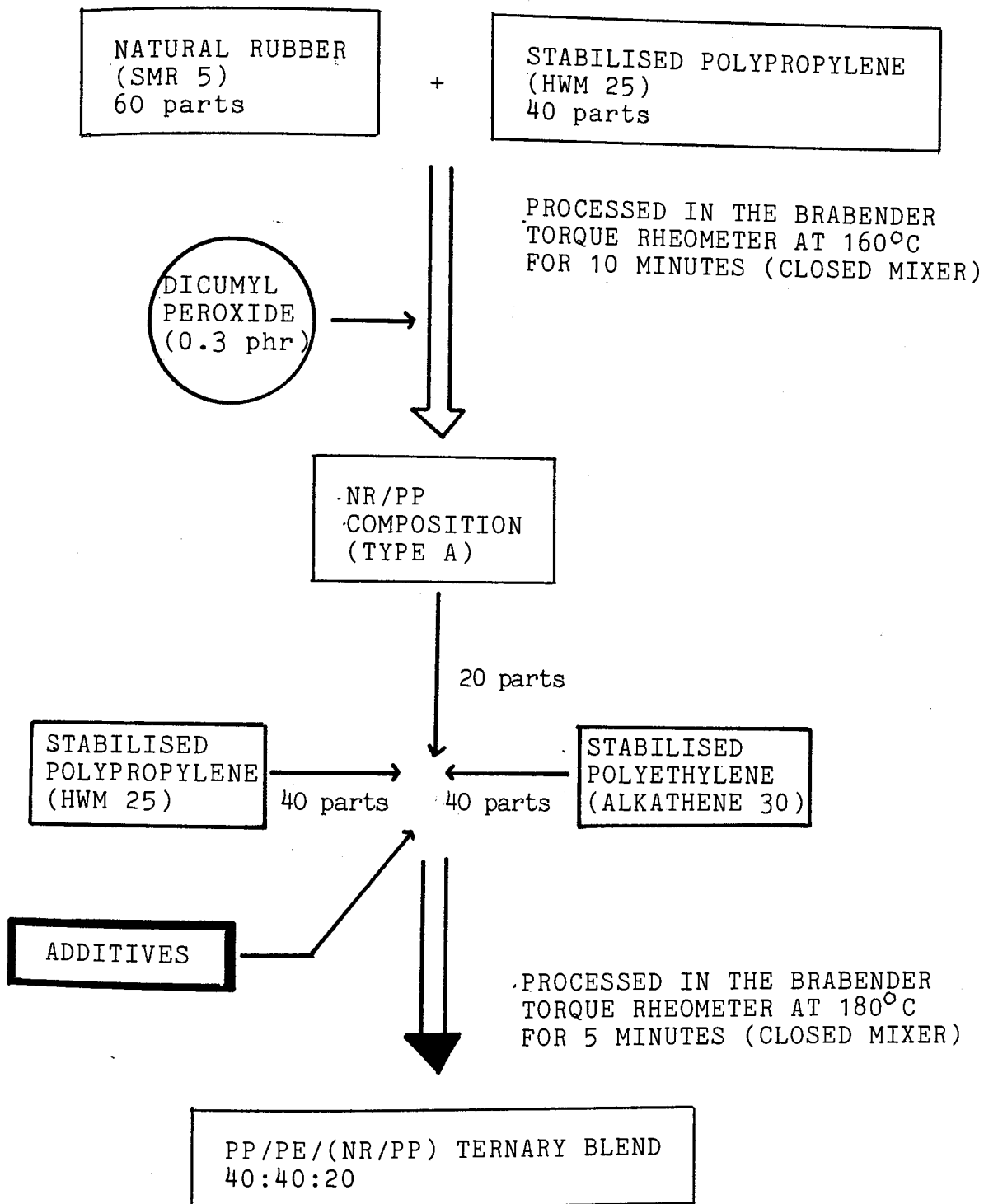

GROUP I.1

Diagram 5.3 Schematic operation of the preparation of PP/PE/(NR/PP) ternary blend (Group I.1)

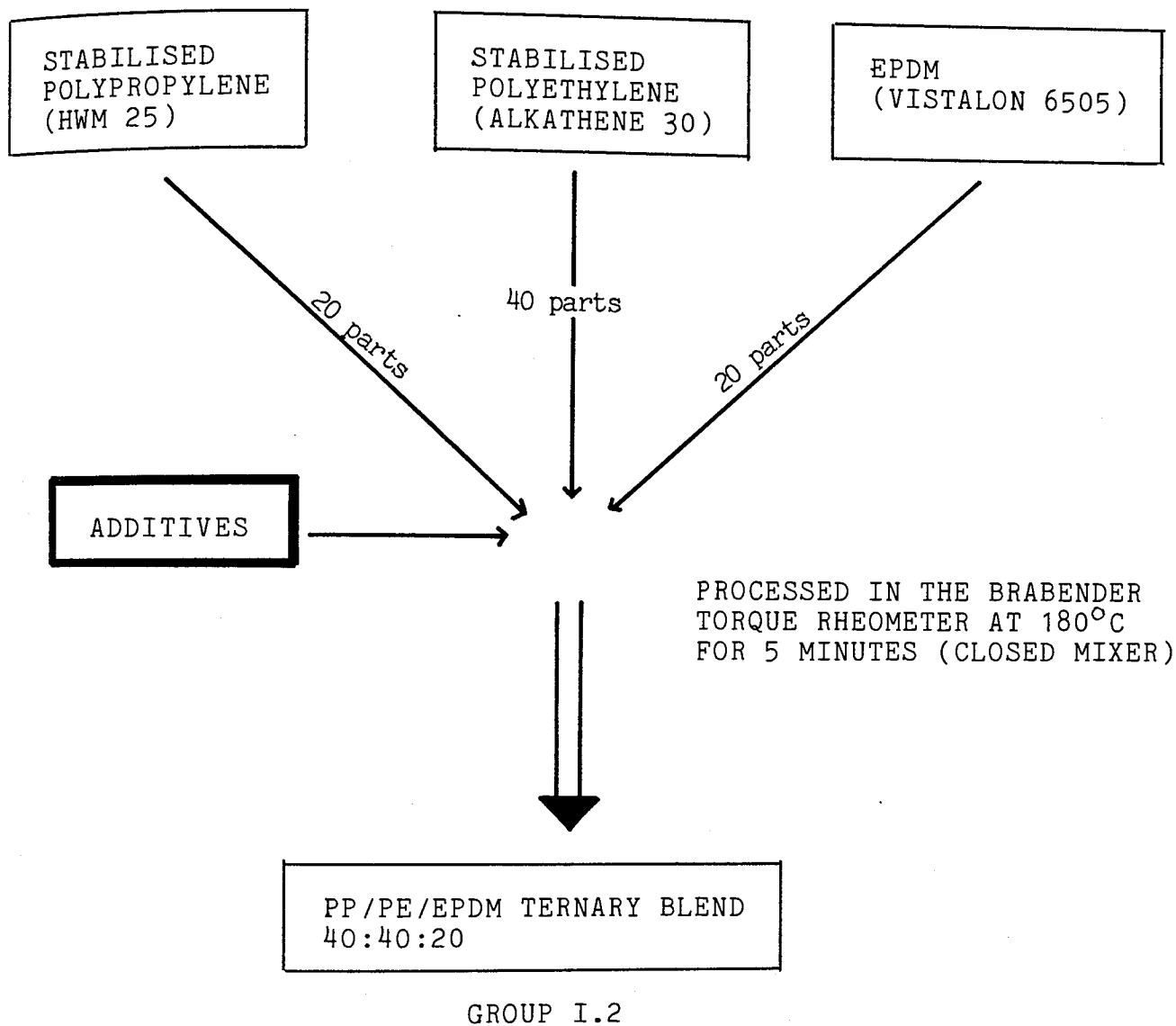
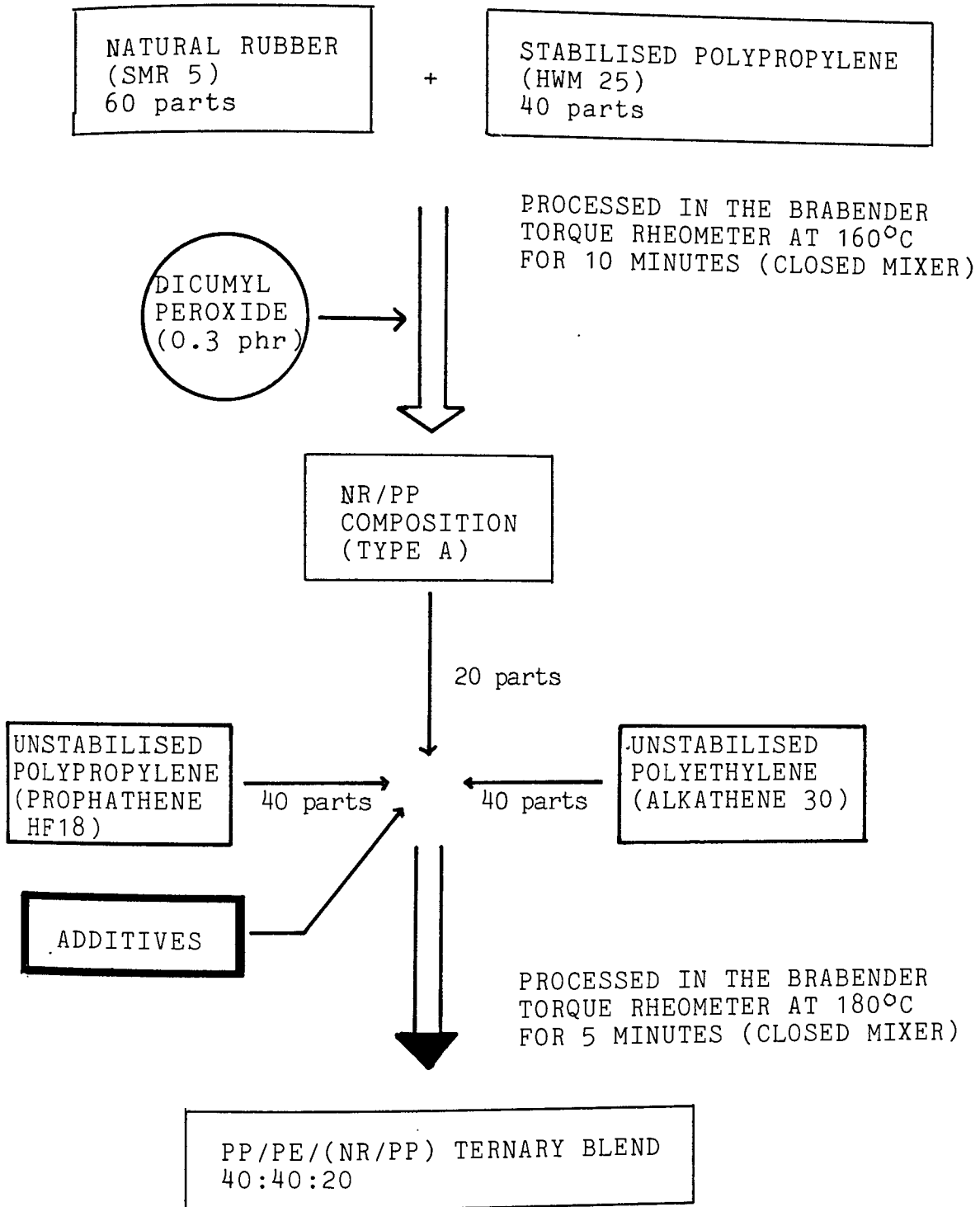
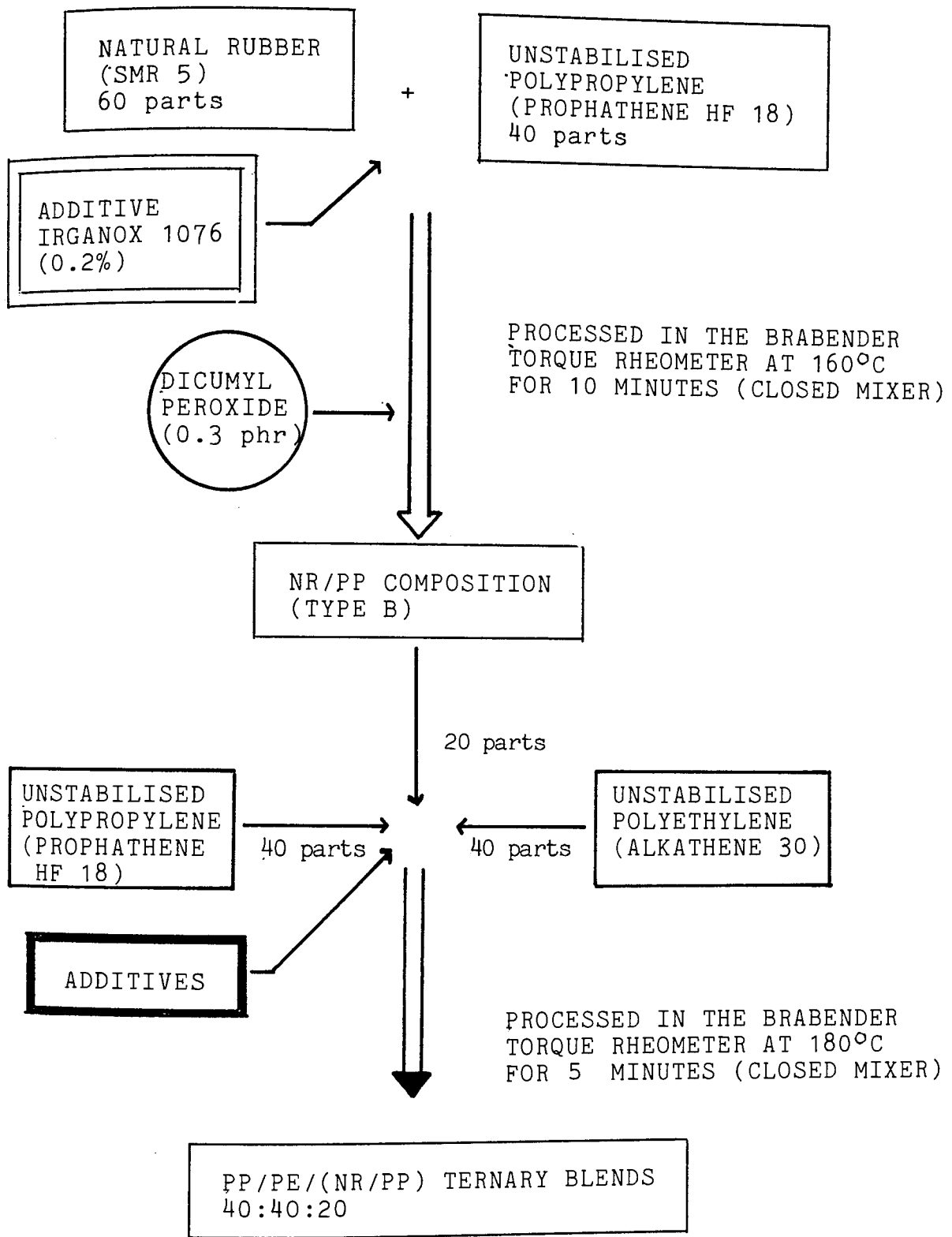

Diagram 5.4 Schematic operation of the preparation of PP/PE/EPDM ternary blend (Group I.2)



GROUP II.1

Diagram 5.5 Schematic operation of the preparation of PP/PE/(NR/PP) ternary blends (Group II.1)



GROUP II.2

Diagram 5.6 Schematic operation of the preparation of PP/PE/(NR/PP) ternary blends (Group II.2)

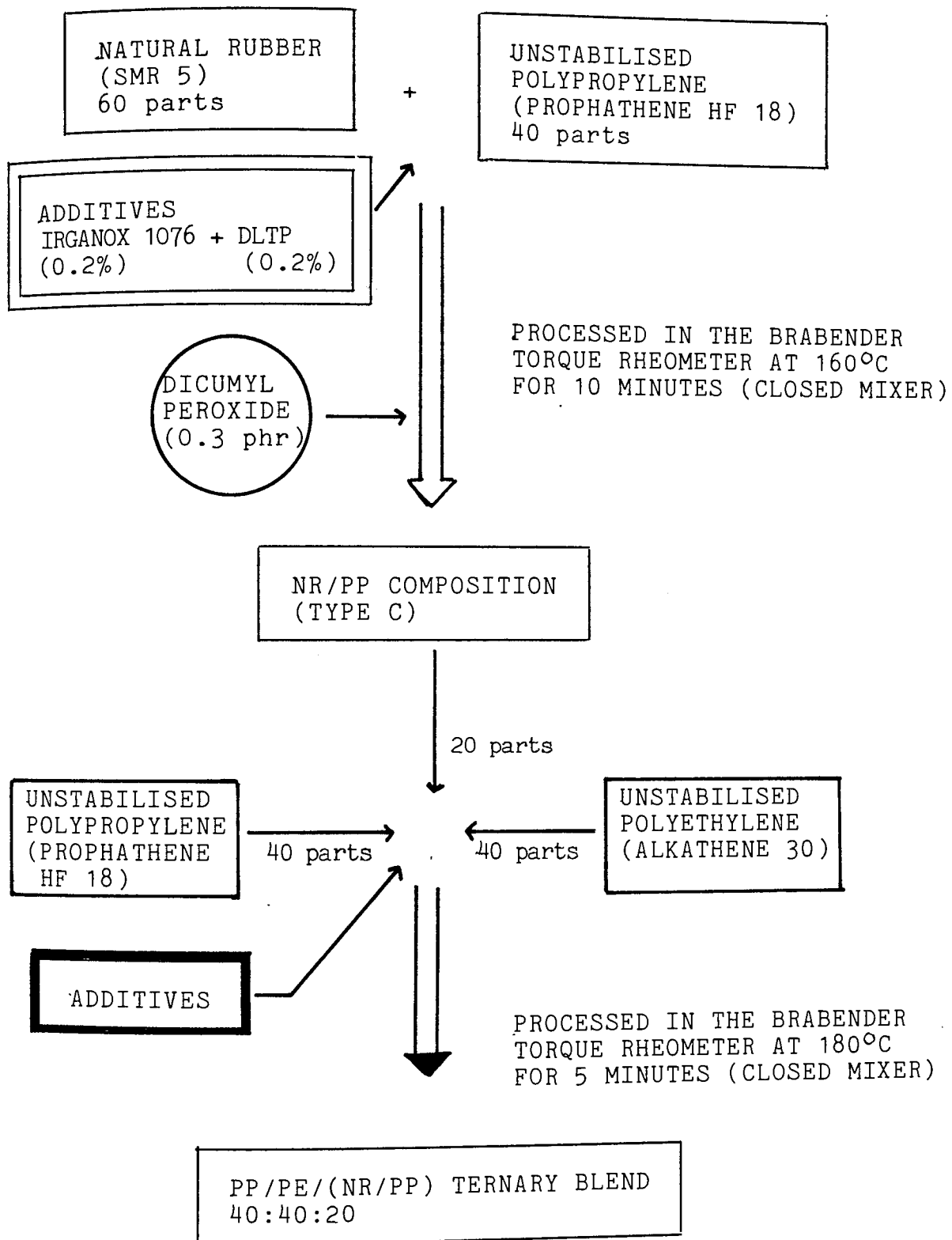

GROUP II.3

Diagram 5.7 Schematic operation of the preparation of PP/PE/(NR/PP) ternary blends (Group II.3)



the tensile modulus (Figure 5.2) which decreases with increasing concentration of SPD.

The effect of SPD on impact strength is shown in Figure 5.3. Impact strength increases with increasing concentration of SPD, it levels off at a concentration of 20 percent by weight. The increase in impact strength due to incorporation of 20 parts EPDM is about 560% while in the case of NR/PP composition it is only 400%. Therefore, EPDM is more effective as impact modifier than NR/PP composition in this ternary blend. This may be due to two reasons, first is because EPDM has a higher rubber content than that of NR/PP composition, therefore more energy during impact is transferred to the rubber and thus being dissipated. Secondly EPDM, owing to the similarity of structure of its segments to the phases in PP/PE blends, is more compatible than is NR/PP. This promotes good adhesion between phases. Good adhesion is one of the requirements for a tough polymer blend with high impact strength<sup>(154,158)</sup>. It is clear then, that the maximum concentration of SPD to be incorporated into these particular blends should not exceed 20 percent by weight (see Figure 5.3).

The other effect of incorporating an elastomer into a thermoplastic polyblend is a decrease in rigidity since the rigidity of elastomers is lower than that of plastics. Figure 5.4 shows that mechanical damping ( $\tan \delta$ , at 20°C) increases with increasing concentration of SPD, while the complex modulus ( $E^*$ ) decreases commensurately. It has been found<sup>(157)</sup>

in HIPS that as the concentration of polybutadiene rubber increases, the mechanical damping increases and the complex modulus decreases. This is also due to the difference in the glass transition temperatures ( $T_g$ ) of both components;  $T_g$  of polybutadiene is much lower than polystyrene. Therefore, increasing concentration of rubber causes a reduction in the stiffness.

Blends containing EPDM show lower MFI values than the corresponding blends containing NR/PP composition (Figure 5.5). This implies that blends containing EPDM have higher viscosities than that of blends containing NR/PP composition. It could be due to a higher rubber content in blends containing EPDM, resulting in a higher effective value concentration of rubber particles which includes not just the volume fraction of EPDM, but also involves PP or PE aggregates or particles trapped in the EPDM particles.

Table 5.2 shows the effect of different processing procedures (using Busko Kneader and Brabender Torque rheometer) on properties of PP/PE blends processed in the presence of different concentration of NR/PP composition as SPD. It is clear that the processing procedure does not alter the properties to any significant extent.

#### 5.2.1.2 Injection Moulded Samples

NR/PP composition was the only SPD used in these experiments. Figure 5.6 shows the effect of NR/PP composition on the tensile properties of blends processed in the Busko Kneader

Properties	PE/PP blends processed in a Brabender					PE/PP blends processed in a Busko Kneader								
	NR/PP concentration (%)					NR/PP concentration (%)								
	0	5	10	15	20	25	30	0	5	10	15	20	25	30
Tensile Strength (MPa)	9.5	9.2	8.6	8.0	7.0	6.2	5.5	10.0	9.4	9.0	8.2	7.6	6.8	6.0
Elongation at Break (%)	30	35	40	56	80	105	140	25	28	33	40	50	70	115
Tensile Modulus (MPa)	107	102	95	88	85	83	80	123	118	98	93	90	88	85
Impact Strength (g.cm.sec <sup>-2</sup> x 10 <sup>9</sup> )	18	22	30	48	58	60	61	15	18	24	40	51	58	59
Mechanical Damping (tan δ x 10 <sup>-2</sup> )	6.5	7.0	8.0	8.5	9.0	9.0	9.0	6.5	6.5	7.0	8.0	8.0	8.5	8.5
Complex Modulus (E*) (dyne cm <sup>-2</sup> x 10 <sup>9</sup> )	14	13	12	11.5	11	10.7	10.5	14.5	14	13	12	11.5	11	10.7

Table 5.2 Effect of processing on PP/PE blends (in Brabender Torque rheometer and in Busko Kneader) in the presence of NRPP as Solid Phase Dispersant. Samples were compression moulded at 180°C for 3 minutes.

and the samples were prepared by injection moulding. The trend of changes in mechanical properties parallels that observed for blends processed in the Brabender Torque rheometer (Figure 5.1), except that in general, mechanical properties of the injection moulded samples are higher than the corresponding compression moulded samples (c.f. Figure 5.6 and Figure 5.1). This could be due to a better and homogeneous dispersion of PP, PE and NR/PP composition during injection moulding.

The Charpy impact strength increases with increasing concentration of NR/PP composition, while the tensile modulus decreases (Figure 5.7). Flexural modulus of the blends decreases with increasing concentration of NR/PP composition (Figure 5.8). This implies that the addition of SPD brings about a considerable reduction in the rigidity of the blends. The dynamic mechanical properties of the blends are also affected by the addition of SPD. The trend of changes, in general, parallels that observed for the blends processed in the Brabender Torque rheometer (compression moulded samples) (Figure 5.4), where the mechanical damping ( $\tan \delta$ , at 20°C) increases with increasing concentration of SPD, while on the other hand, the shear modulus ( $G^*$ ) decreases (Figure 5.9).

It is clear from these results that NR/PP composition does modify some of the properties of PP/PE blends in a similar way to EPDM. These modifications are summarised below.

Toughness has been improved (Figures 5.3 and 5.7) which is in accordance with the toughening mechanism of thermoplastic by rubbers<sup>(154,159)</sup>. Merz<sup>(154)</sup> originally argued that the impact resistance of HIPS was a consequence of energy absorption by the rubber phase during the tensile fracture, while Bucknall and Smith<sup>(159)</sup> reported the formation of multiple crazes around the rubber particles during deformation, ascribing impact resistance to their energy of formation. Therefore, toughening is achieved by transferring large amounts of the externally applied energy from the matrix to the rubber particles. Hence the crack formation occurs in the rubber phase. Plates 5.1 to 5.6 verify the above in that as the SPD is added to PP/PE blend, the fracture where the blends fail during impact occurs in the rubber particles instead of in the PP/PE matrix. It is clear that as the concentration of SPD increases, more fractured rubber is shown which results in a higher impact strength.

On the other hand, NR/PP composition tends to decrease the rigidity of the PP/PE blends (Figures 5.4 and 5.8). Newman<sup>(160)</sup> in his novel approach associated this with an increase in the free volume on the matrix near the rubber particles when an external stress is applied. This allows an increase in matrix mobility and an associate increase in cold flow. Other properties which are related to this are, mechanical damping ( $\tan \delta$ ), shear modulus and tensile modulus. The mechanical damping increases with increasing



Plate 5.1 - SEM micrograph of a fractured surface of PP/PE (50/50) blends.

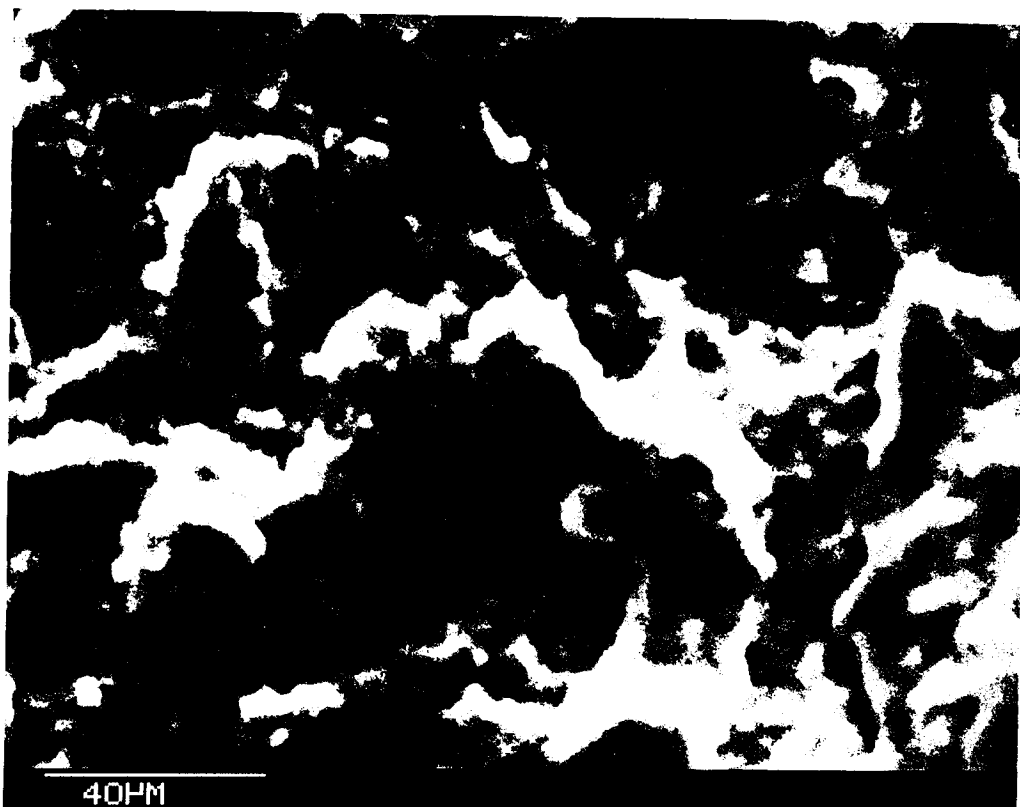

Plate 5.2 - SEM micrograph of a fractured surface of PP/PE/(NR/PP) (47.5/47.5/5) blend.

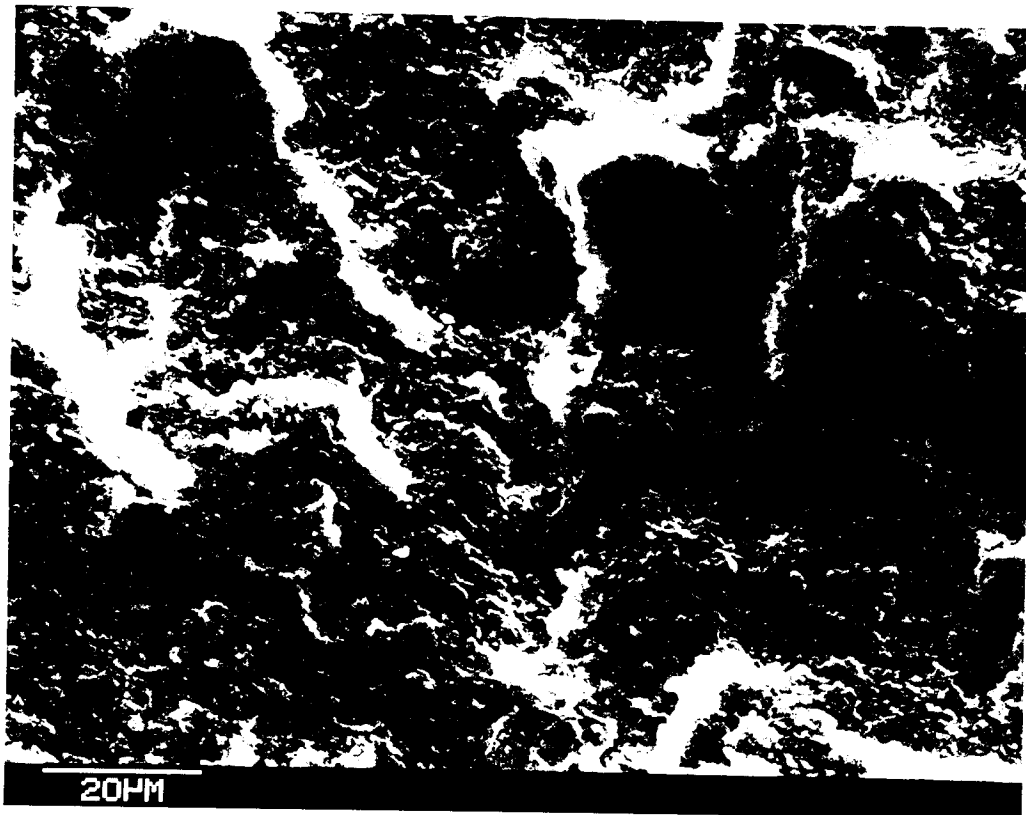

Plate 5.3 - SEM micrograph of a fractured surface of PP/PE (NR/PP) (45/45/10) blend.

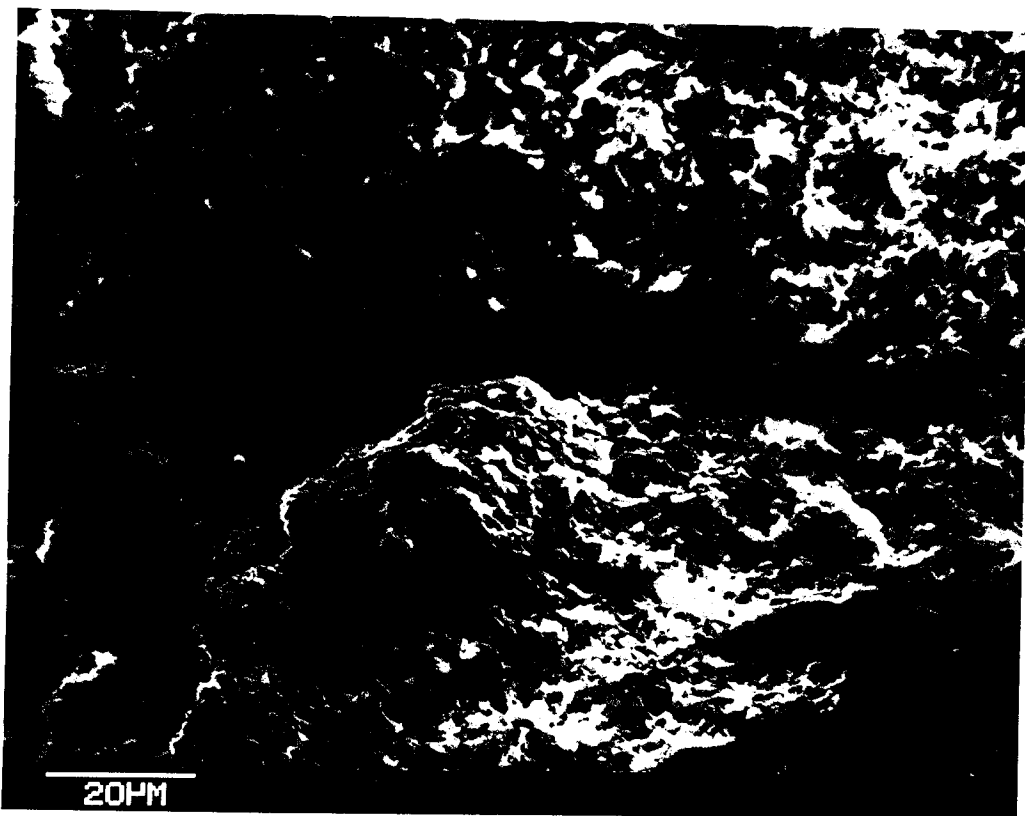

Plate 5.4 - SEM micrograph of a fractured surface of PP/PE/(NR/PP) (42.5/42.5/15) blends.

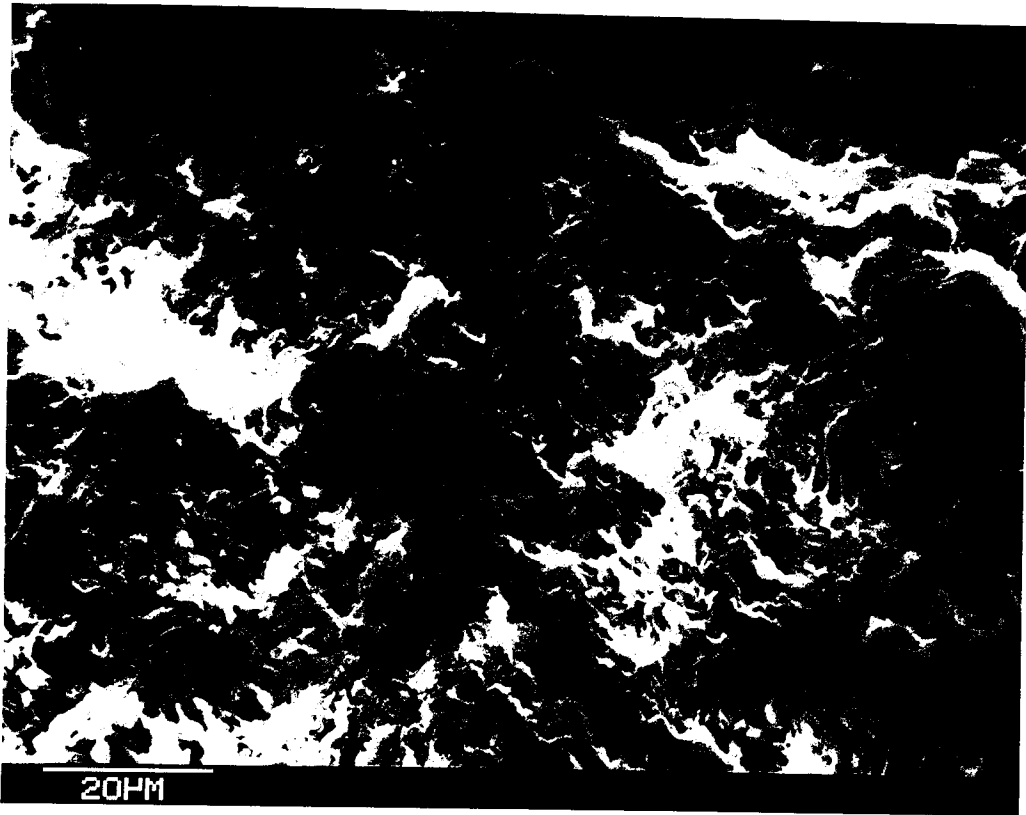

Plate 5.5 - SEM micrograph of a fractured surface of PP/PE/(NR/PP) (40/40/20) blend.

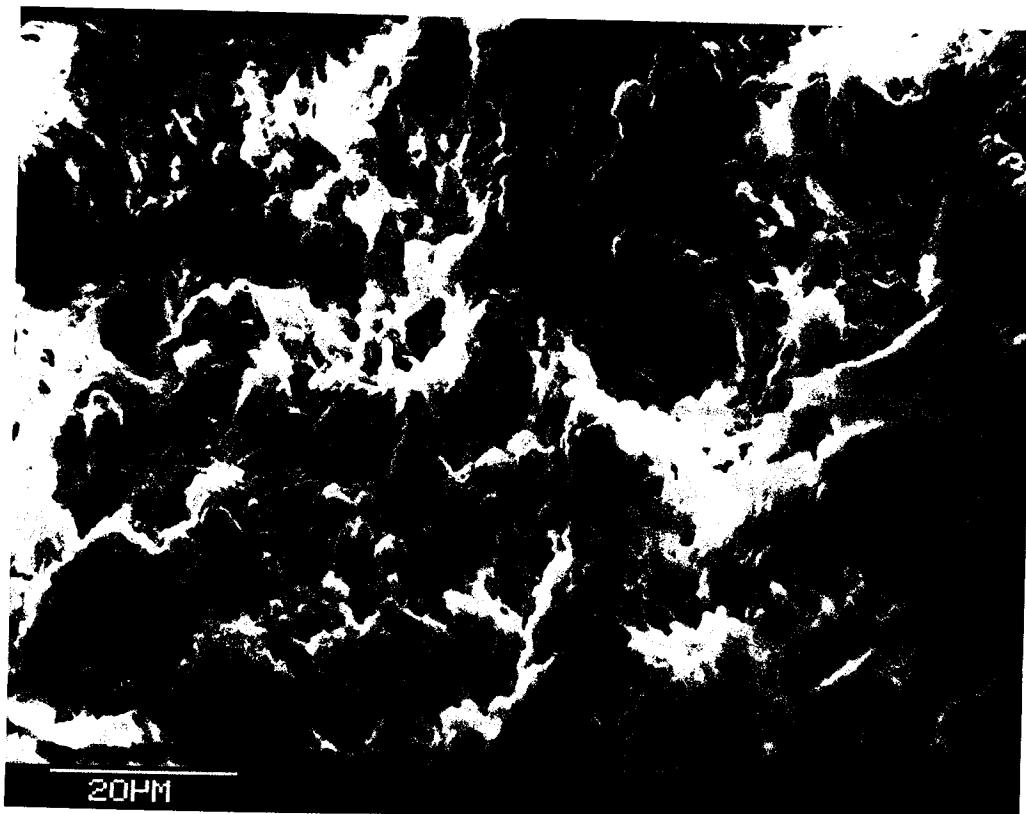

Plate 5.6 - SEM micrograph of a fractured surface of PP/PE/(NR/PP) (37.5/37.5/25) blend.



concentration of SPD (Figure 5.9), it is well understood that the addition of rubber which has a lower glass transition temperature ( $T_g$ ) affects the viscoelasticity of the blends. The rubber will also increase the flexibility of the blends which as a consequence, will decrease the modulus. Similarly, tensile properties are also affected by the addition of SPD on the blends (Figures 5.1 and 5.6), the higher the concentration of SPD, the lower the tensile strength, while the elongation at break increases with increasing concentration of SPD.

#### 5.2.2 Effect of SPD on the Photo-oxidative Stability of PP/PE Blends

Figures 5.10 and 5.11 show that the solid phase dispersants used (EPDM and NR/PP composition) increase the rate of photo-oxidation of PP/PE blends. The increase in carbonyl index during UV-irradiation of PP/PE blends in the presence of NR/PP composition is much higher than that shown in the presence of EPDM. This might be anticipated in view of the much higher level of unsaturation in the natural rubber phase in NR/PP composition when compared to EPDM. This is similar to the behaviour of HIPS<sup>(109)</sup>, in which polybutadiene rubber has a similar level of unsaturation to that of natural rubber, and hence strongly sensitises the polystyrene phase to photo-oxidation.

The effect of both EPDM and NR/PP composition as SPD on the impact strength of PP/PE blends during UV-irradiation are

shown in Figures 5.12 and 5.13. Impact strength decreases dramatically during UV-irradiation with increasing concentration of SPD. Again, in this case, EPDM shows better results than NR/PP composition. Impact strength, both before and after irradiation of blends containing EPDM is higher than that of NR/PP composition, indicating that NR/PP causes more deterioration in impact strength than does the EPDM due to the fact that natural rubber is more prone to photo-oxidation, rendering it ineffective as a toughening agent. For solid phase dispersant to exert its function, it must be located at the interface of the components constituting the blends, and so its degradation will be particularly critical to the mechanical behaviour of the blend. In this case, natural rubber is degraded rapidly, hence the blends containing NR/PP composition show a dramatic decrease in their impact strength during UV-irradiation.

Figure 5.14 and 5.15 show the changes in complex modulus of PP/PE blends containing NR/PP composition and EPDM respectively during UV-irradiation. It is shown that different results of photo-oxidation have occurred in these two types of blends. Blends containing NR/PP composition become softer, while the ones containing EPDM become brittle which was also observed for HiPS during UV-irradiation <sup>(156)</sup>. The changes in mechanical damping ( $\tan \delta$ ) of the above blends also show the different results of photo-oxidation on these two types of blends (Figures 5.16 and 5.17).

These results show that NR/PP composition is less effective as an SPD than EPDM; more susceptible to photo-oxidation and hence the rapid deterioration of long term properties (Figures 5.12 and 5.13) which means that NR/PP composition is not suitable for outdoor applications. Some of the factors which may contribute to this lower photo-oxidative stability are discussed below.

The nature of the constituents of NR/PP composition compared to those of EPDM must play an important role. Natural rubber has a higher unsaturation level than that of EPDM. The amount of unsaturation present in NR is about 14.3 mole percent polyisoprene, while in EPDM is usually within the range of 0.6 to 1.0 mole percent diene<sup>(161)</sup>. Unsaturation is one of the chromophoric groups which is chiefly responsible for the "photo-activity" of polymers, giving rise to sensitised degradation of polyolefins<sup>(162-166)</sup>. The other important factor is the location of the unsaturation in the rubbers. The distinguishing characteristic of EPDM rubber is that the unsaturation is in the side chains, pendant to the main chain, consequently the oxidation of unsaturation will have no effect upon the properties of rubber<sup>(160)</sup>. While in natural rubber, the unsaturations are in the main chain, therefore degradation definitely will affect the polymer chains. Moreover, there is more polypropylene in blends containing NR/PP composition than in the corresponding blends containing EPDM, and since polypropylene is more susceptible to oxidation than polyethylene<sup>(167)</sup>, one

expects blends containing NR/PP composition to be more sensitive to UV-light.

Furthermore, processing of NR/PP under high shear and high temperature conditions leads to the formation of photosensitisers and hence contributes to higher photo-oxidation levels. It has been known<sup>(166)</sup> that hydroperoxides and carbonyl groups are formed as a result of degradative reactions during processing. Therefore, the need to use stabilisers for PP/PE blends containing NR/PP composition is inevitable.

### 5.2.3 Effect of Stabilisers on Properties of PP/PE/SPD (40:40:20) Blends

#### 5.2.3.1 Effect of Stabilisers on the Initial Properties of PP/PE/SPD (40:40:20) Blends

The effect of stabilisers on the initial properties of PP/PE/SPD (40:40:20) blends where the SPD is made of NR/PP composition (see Diagram 5.3) is shown in Table 5.3. It is quite clear that the initial properties of the blends are not affected by the stabilisers to any extent.

Initial properties of PP/PE/EPDM (40:40:20) blends (Group I.2, Diagram 5.4) are also not affected by the stabilisers used (Table 5.4). Based on these results, it is clear that these polymer blends (Groups I.1 and I.2) are quite stable to thermal degradation during processing. This

Properties	Samples (Group I.1)					
	1.1	1.2	1.3	1.4	1.5	1.6
Tensile strength (MPa)	6.70	6.50	6.80	6.75	6.45	6.50
Yield strength (MPa)	7.50	7.30	7.60	7.60	7.30	7.30
Elongation at break (%)	70	75	68	65	75	75
Tensile Modulus (MPa)	85	80	83	85	82	82
MFI at 230°C/50N (g/10 min)	3.9	4.5	4.0	3.8	4.1	4.2

Table 5.3 Initial properties of PP/PE/SPD(40:40:20) (Group I.1)\*

\* see Diagram 5.3

Properties	Samples (Group I.2)					
	2.1	2.2	2.3	2.4	2.5	2.6
Tensile strength (MPa)	5.20	5.40	5.00	4.90	4.90	4.90
Yield strength (MPa)	5.80	6.00	5.40	5.40	5.50	5.40
Elongation at break (%)	130	130	140	140	145	140
Tensile modulus (MPa)	78	80	76	76	77	76
MFI at 230°C/50N (g/10 mins)	2.2	2.4	2.0	2.0	2.0	2.0

Table 5.4 Initial properties of PP/PE/EPDM(40:40:20) blends (Group I.2)\*

\* see Diagram 5.4

may be due to the fact that both PP and PE used for these blends are commercially stabilised. Processing does not, therefore, cause any significant change in the initial properties. The differences in the tensile properties and MFI of the two blends described in Groups I.1 and I.2 must be due to the different rubber levels in the SPD's as described previously (see Section 5.2.1).

In the case of PP/PE/SPD blends of Group II (see Diagrams 5.5; 5.6 and 5.7), it is clear that stabiliser systems have also no significant effect on the initial properties of the blends (Table 5.5), except for blends which are stabilised with the combination of Irganox 770 and Ni-dithiophosphate (Sample II.1.9; II.2.9 and II.3.9) which shows slightly lower physical properties and MFI values. This may be due to the fact that hindered phenols antagonise with Ni-dithiophosphate<sup>(168)</sup>.

Based on these initial properties examination (c.f. Tables 5.3 and 5.4), it is apparent that PP/PE/(NR/PP) blends of unstabilised PP and PE (Group II, Diagrams 5.5, 5.6 and 5.7) have undergone some thermal degradation when compared with similar blends but containing commercially stabilised PP and PE (Group I.1, Diagram 5.3).

Samples	Properties				
	T.S. (MPa)	Y.S. (MPa)	E.B. (%)	T.Mod (MPa)	MFI (g/10 min)
Group II.1					
1.1	6.00	6.30	60	93	5.70
1.2	6.20	6.92	40	84	5.90
1.3	6.10	6.50	45	82	6.00
1.4	6.25	6.95	40	80	5.60
1.5	5.60	6.10	50	83	5.90
1.6	5.90	6.40	45	83	5.20
1.7	6.10	6.70	40	91	5.40
1.8	5.90	6.40	50	93	5.20
1.9	5.00	5.80	40	78	7.05
Group II.2					
2.1	5.60	6.10	50	80	5.90
2.2	6.00	6.50	45	81	5.15
2.3	5.90	6.40	45	80	6.00
2.4	6.30	6.70	50	84	5.40
2.5	6.20	6.90	50	84	5.30
2.6	5.90	6.40	50	80	5.80
2.7	6.10	6.50	40	90	5.40
2.8	5.30	5.90	45	85	5.30
2.9	5.10	5.83	50	83	6.30
Group II.3					
3.1	5.60	6.00	60	83	5.00
3.2	6.40	7.00	60	80	5.80
3.3	6.40	7.00	60	84	5.60
3.4	6.50	7.00	60	84	4.80
3.5	6.50	7.05	70	80	4.80
3.6	6.20	6.80	50	89	5.00
3.7	6.10	6.70	60	81	5.20
3.8	5.40	5.83	40	91	5.10
3.9	5.00	5.69	45	80	6.10

Table 5.5 Effect of stabilisers on the initial properties of PP/PE/TPNR(40:40:20) blends, Group II



### 5.2.3.2 Effect of Stabilisers on the Photo-oxidative Stability of PP/PE/SPD (40:40:20) Blends

Infra-red examination of films of PP/PE/SPD (40:40:20) blends during UV-irradiation shows the effect of stabilisers on photo-oxidation (Figures 5.18-5.22). Figure 5.18 indicates that combination of HOBP and Cyasorb 1084 is the most effective. This is due to the synergism offered by such stabiliser systems. HOBP (UV 531), which undergoes a "keto-enol" tautomerism (Scheme 5.1), absorbs some of the UV-light and dissipates it harmlessly<sup>(169)</sup>. It can also scavenge free radicals sacrificially<sup>(170)</sup>. On the other hand, Cyasorb 1084 decomposes hydroperoxide<sup>(169)</sup>

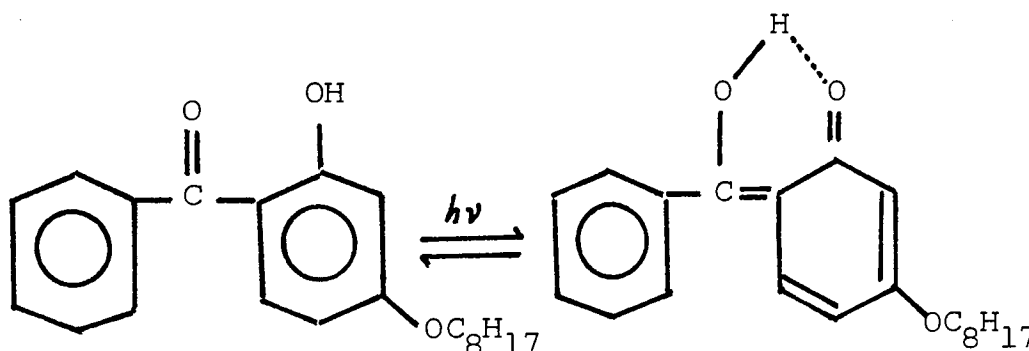

Scheme 5.1 Keto-enol tautomerism of o-hydroxy benzophenone

which become the dominant source of free radicals<sup>(171)</sup>. The least effective UV-stabiliser studied here is Tinuvin 770 (Sample 1.6, Group I.1), inspite of the fact that it is known to have a powerful light stabilising

effect in PP<sup>(172)</sup>. Protective action of this stabiliser is due to its conversion into the corresponding nitroxyl derivatives by oxidising agents e.g., hydroperoxides and the regeneration of this radical<sup>(173)</sup> (Scheme 5.2).

Figure 5.19 shows the effect of stabilisers on the photo-oxidative stability of PP/PE/EPDM (40:40:20) blends (Diagram 5.4). The combination of HOBP and Cyasorb 1084 is again found to be the most effective stabiliser system as in the case with PP/PE/(NR/PP) blends. Tinuvin 770 behaves differently in blends containing EPDM. Its effectiveness is similar to that offered by the HOBP plus Cyasorb 1084 system. This may be due to the lower level of unsaturation in EPDM and problems of oxygen diffusion in NR.

Stabilisation of PP and PE in PP/PE/(NR/PP) blends which contain (NR/PP) composition type A (Group II.1, Diagram 5.5) seems to have a significant effect on the photo-oxidative stability (Figure 5.20). It can be seen from this figure that the most effective photo-antioxidant system is that based on combination of Irganox 1076 (0.2%) + HOBP (0.2%) and Cyasorb 1084 (0.2%) (i.e., Group II, Sample 1.4, Table 5.1). This must be due to the synergetic effect of Irganox 1076 (a chain-breaking antioxidant which inhibits chain reactions during UV-exposure) with HOBP and Cyasorb 1084 which act as UV-absorbers and hydroperoxide decomposer respectively. On the other hand, the system containing Irganox 1076 + Ni-

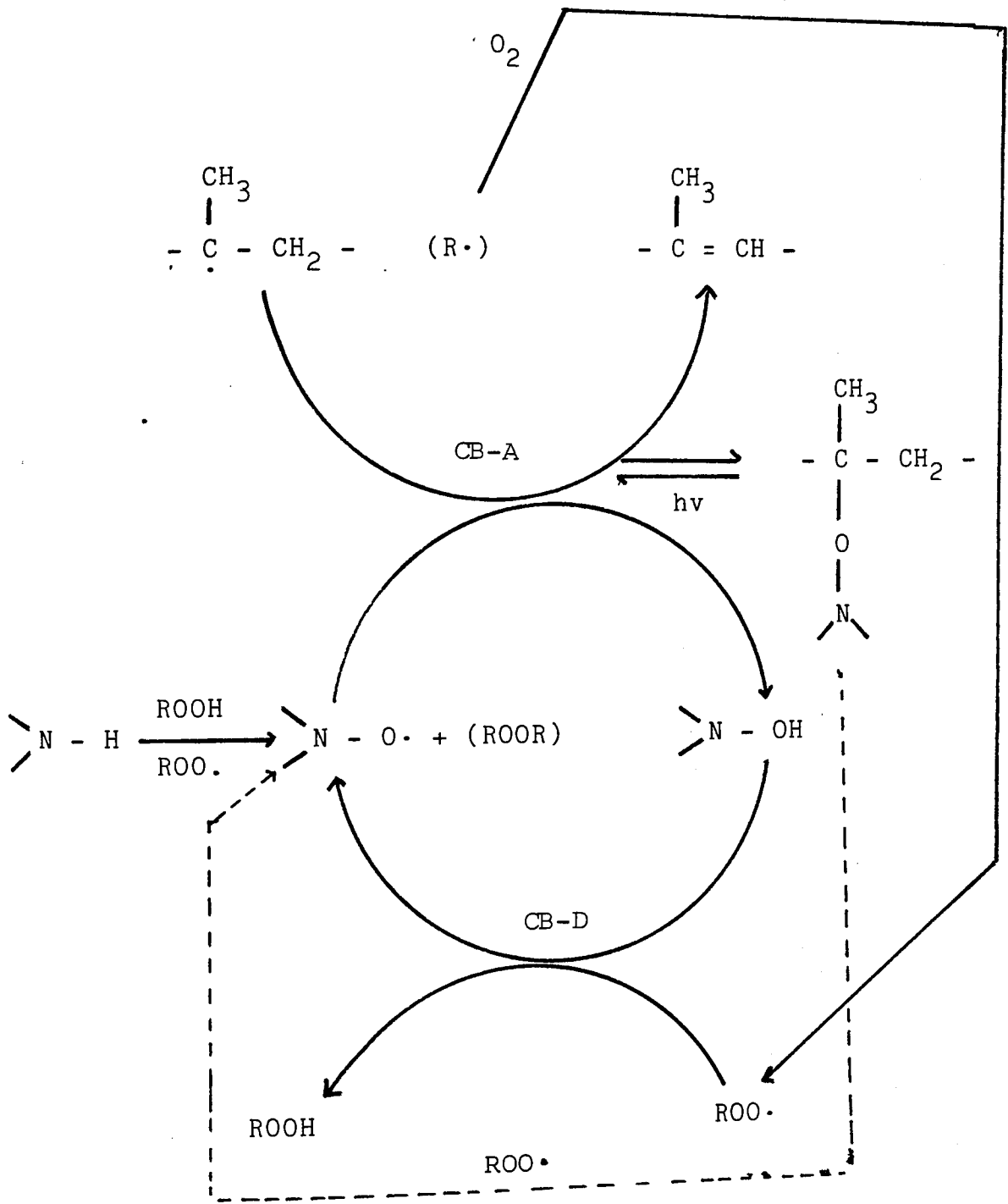

Scheme 5.2 Nitroxyl radicals for UV-stabiliser for polypropylene (173)

dithiophosphate (Group II.1, Sample 1.9) increases the rate of growth of carbonyl group more than the control at longer irradiation time, although it stabilises the blends initially. These two stabilisers have been found to show antagonistic effect<sup>(174)</sup> during photo-oxidation of polyolefins. It was suggested<sup>(174)</sup> that this is due to the fact that the hindered phenol (Irganox 1076) or its quinonoid oxidation product photosensitises the composition of dithiophosphates leading to a decrease in their effectiveness. This is clear in all samples containing this system (e.g., Samples 1.10; 1.11; 1.12 and 1.13, Group II.1).

For unstabilised PP and PE blends containing NR/PP composition (when PP in the NR/PP composition is also unstabilised) (Groups II.2 and II.3, Diagrams 5.6 and 5.7), the effect of stabiliser systems on the photo-oxidative stability of the blend (Figures 5.21 and 5.22) is almost similar to that observed in Group II.1 (Figure 5.20).

It is clear that the most effective stabiliser system is the one based on combination of a chain breaking antioxidant, peroxide decomposer and UV-screen (e.g., Irganox 1076, HOBP and Cyasorb 1084). However, stabiliser systems based on combinations of Irganox 1076 plus Tinuvin 770, and Irganox 1076 plus Ni-dithiophosphate, are less effective.

The loss of impact strength during UV-irradiation of PP/PE/SPD blends is shown in Figures 5.23 to 5.26. It is

clear from Figure 5.23, that the loss of impact strength for blends containing EPDM is less than that of blends containing NR/PP composition. This implies that EPDM is more resistant to photo-oxidation (see Section 5.2.2). A good correlation between the growth of formation of carbonyl groups and the decrease in impact strength is clear in every sample. This indicates that photo-oxidation occurs in the rubber phase rendering it less effective as a toughening agent (see Section 5.2.2). Systems containing HOBP plus Cyasorb 1084, have a profound effect on inhibiting the deterioration of impact strength in blends containing EPDM as well as those containing NR/PP composition.

Figure 5.24 shows the effect of stabiliser systems on the loss of impact strength of blends containing unstabilised PP and PE while the PP in NR/PP composition is commercially stabilised (Group II.1, Diagram 5.5). It is apparent that the system based on combination of Irganox(0.1%), HOBP(0.2%) and Cyasorb 1084(0.2%) (Sample 1.4) is the most effective stabiliser. While systems containing Irganox 1076 plus Tinuvin 770, and combination of Irganox 1076 plus Ni-dithiophosphate, are less effective. The trend of impact strength loss from blends of Groups II.2 and II.3 is quite similar (Figures 5.25 and 5.26). The synergetic effect of Irganox 1076, HOBP and Cyasorb 1084 combination system has a very profound effect on the photo-oxidative stability of these blends.

Based on these results, it is apparent then that photo-oxidative stability of PP/PE/(NR/PP) blends can therefore be improved by addition of commercial stabilisers which act as both chain-breaking antioxidant and as peroxide decomposers, as well as UV-absorber/screen. The inability of any single stabiliser used in this study to inhibit photo-oxidation of PP/PE/(NR/PP) blends could be partly contributed to the low concentration of the stabiliser used. It was shown (Figure 5.10) that the rubber phase is the most sensitive part of the blend to photo-oxidation due to its high level of unsaturation. Stabilisers incorporated in the blend (see Tables 5.1 and 5.2) at low concentration become dispersed in the whole blend<sup>(175)</sup>, therefore, the protection for the rubber phase is not adequate. Moreover, synergism due to different rules of different stabilisers in a stabiliser system contributes to effective stability compared to a one-component system.

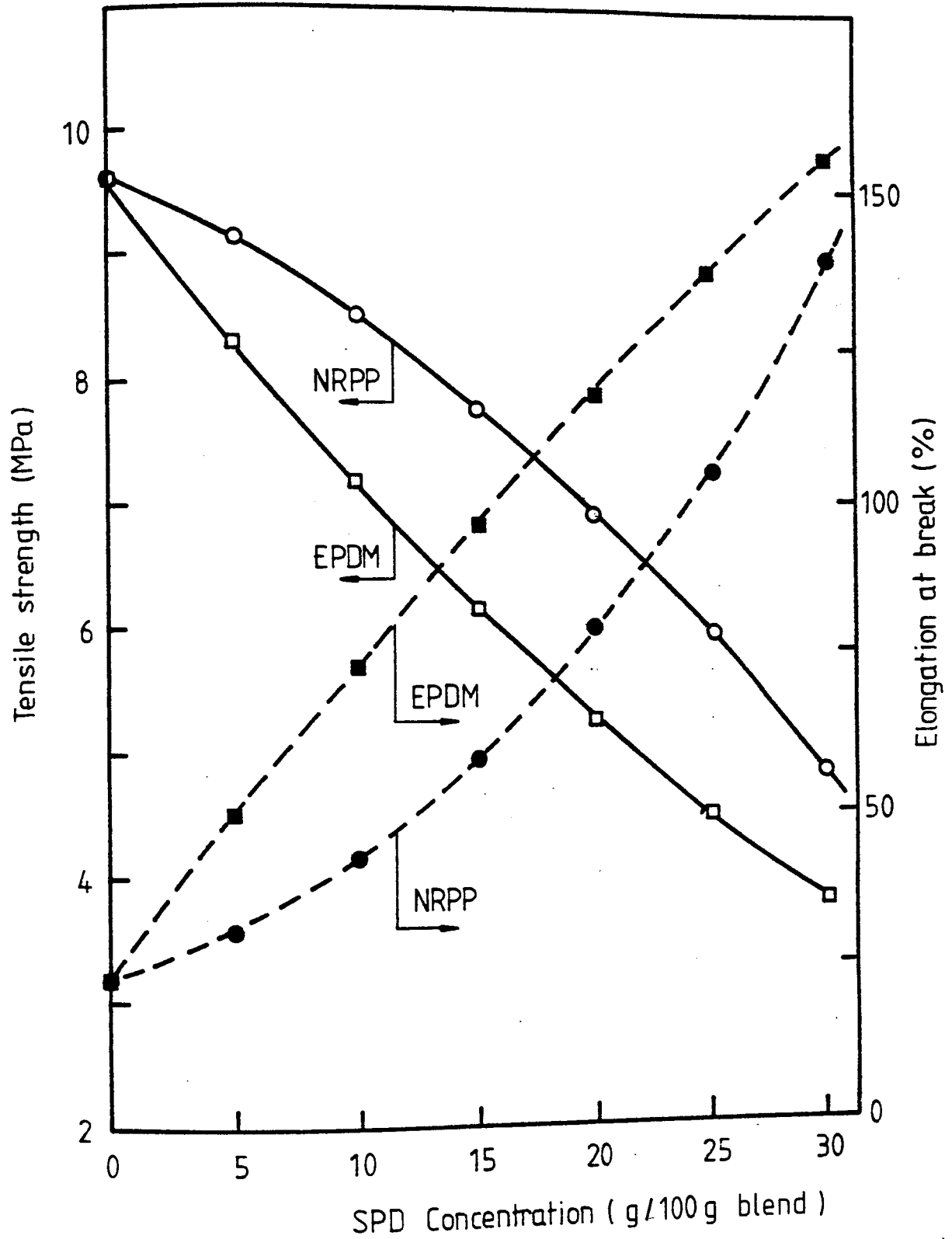

Figure 5.1 - The effect of solid phase dispersant (SPD) on the tensile properties of PP/PE (1:1) blends processed in a Brabender Torque-rheometer at 180 C for 5 minutes. (Compression moulded films).

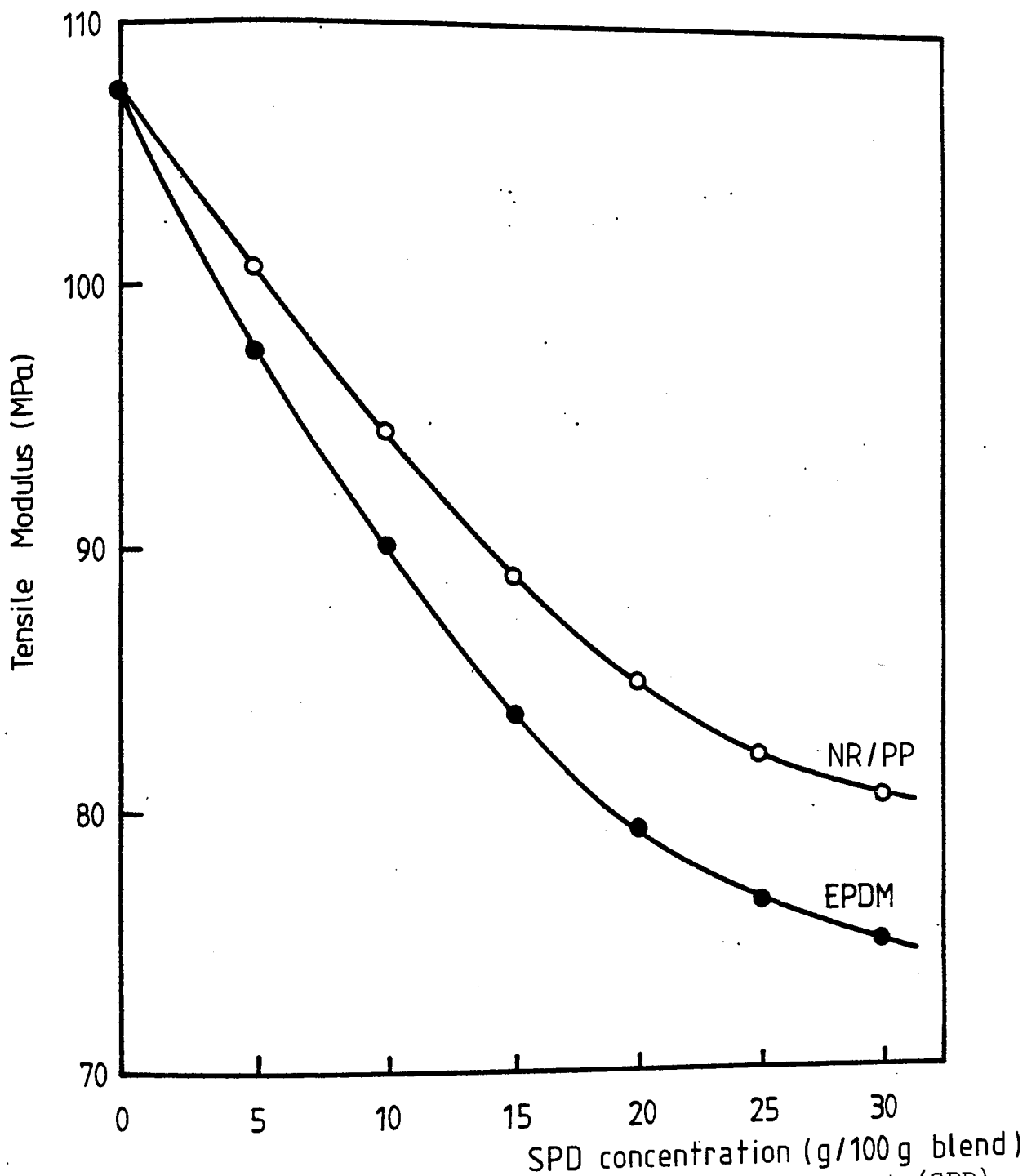

Figure 5.2 - The effect of solid phase dispersant (SPD) on the tensile modulus of PP/PE (1:1) blends processed in a Brabender Torquerheometer at 180 C for 5 minutes (Compression moulded samples).



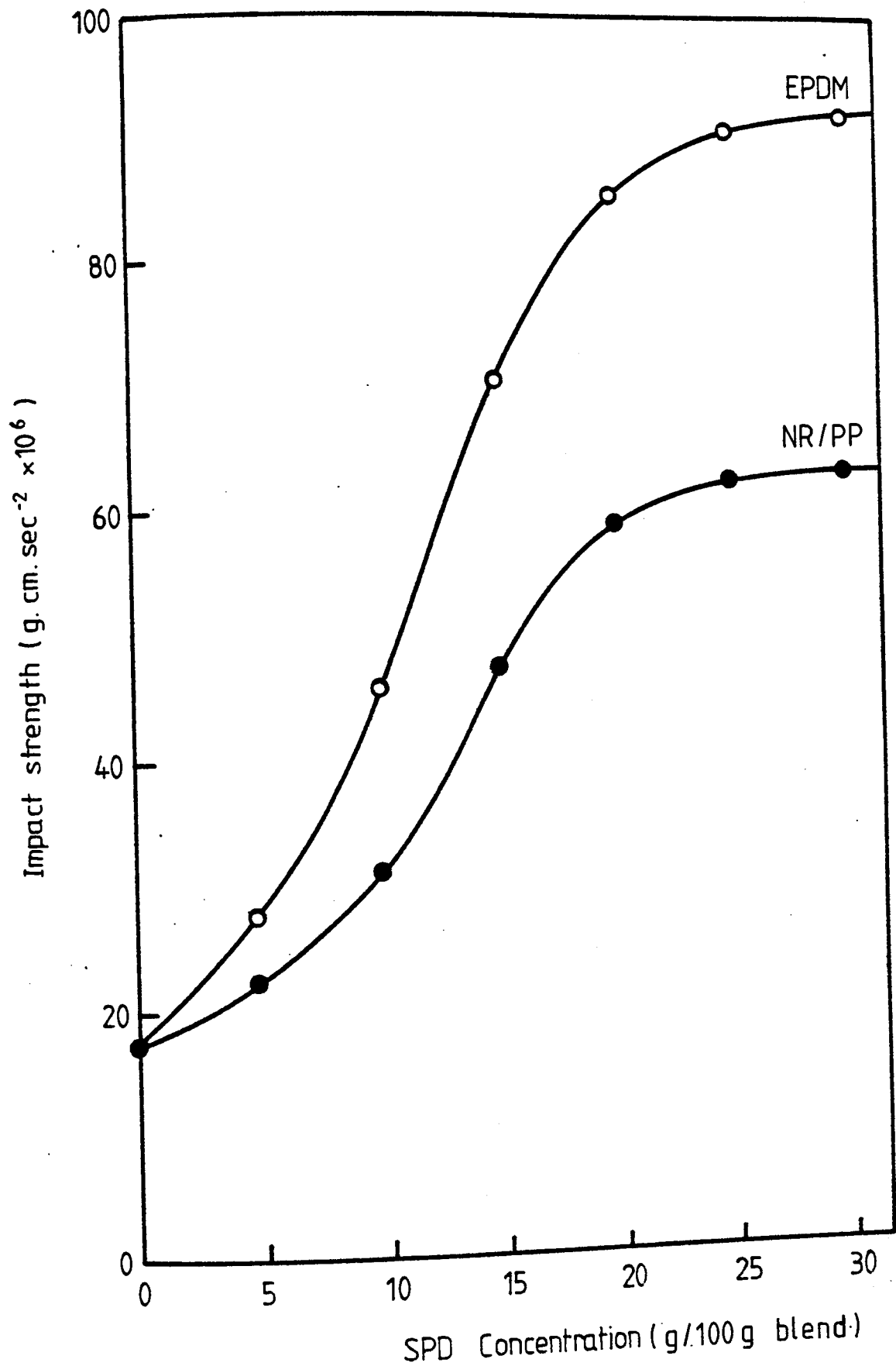

Figure 5.3 - The effect of solid phase dispersant (SPD) on the impact strength of PP/PE (1:1) blends processed at 180°C for 5 minutes (compression moulded samples).

Elastic complex modulus (dynes  $\text{cm}^{-2} \times 10^{-9}$ )

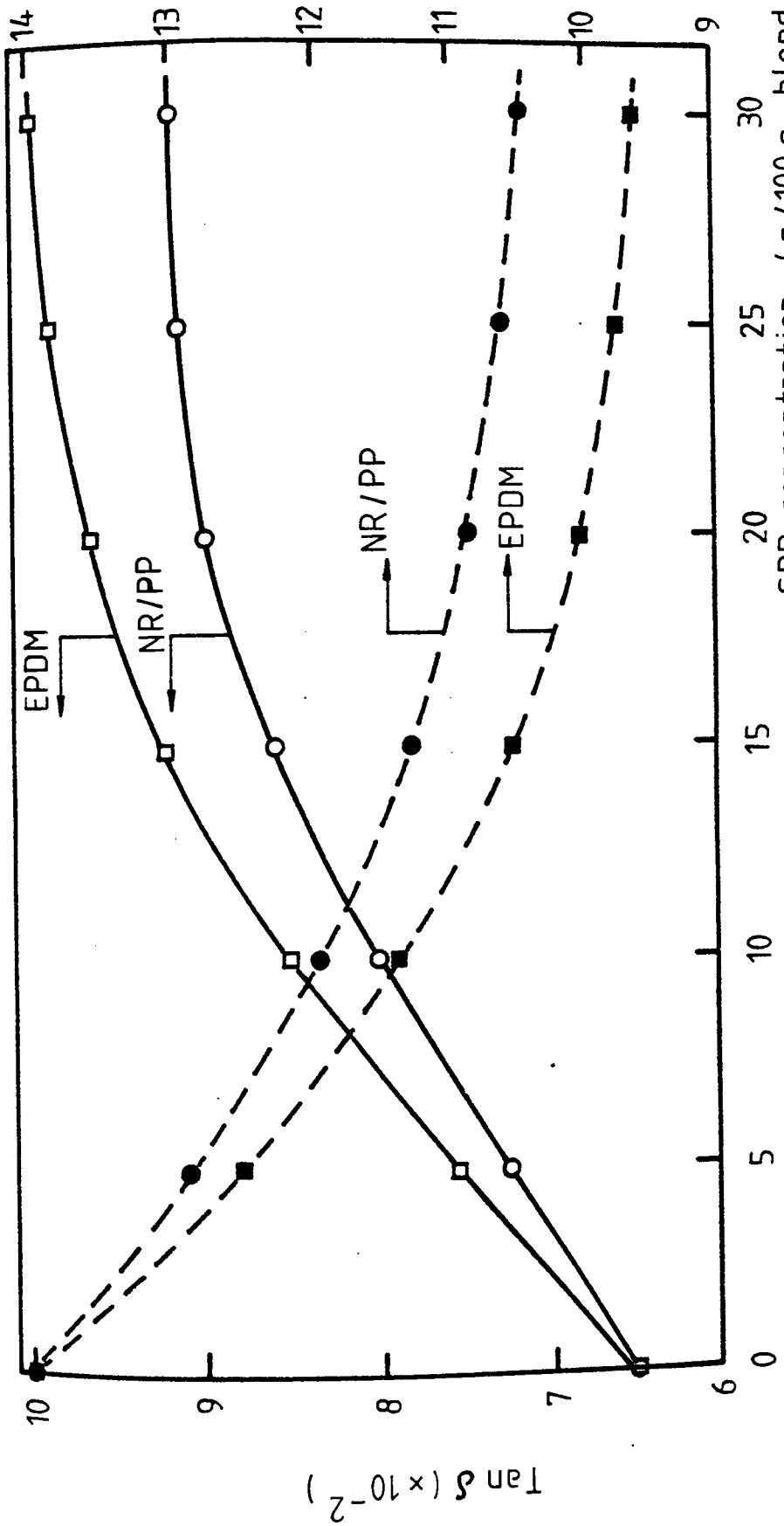

Figure 5.4 - The effect of solid phase dispersant (SPD) on the dynamic mechanical properties of PP/PE (1:1) blend processed in a Brabender Torque-rheometer at 180°C for 5 minutes (compression moulded samples).

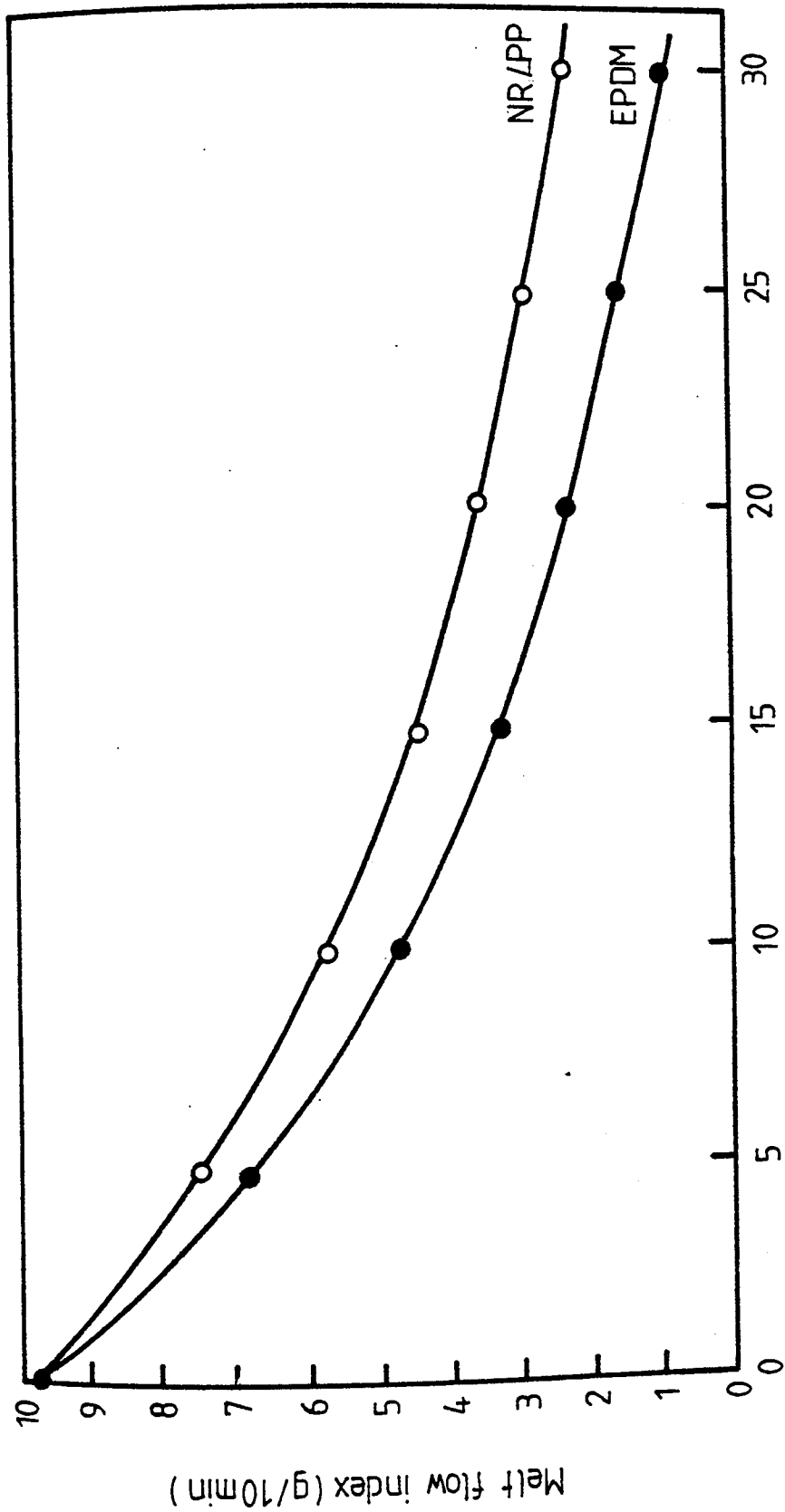

Figure 5.5 - The effect of SPD on the melt flow index of PP/PE(1:1) blends processed in a Brabender Torque rheometer at 180°C for 5 minutes (compression moulded samples).

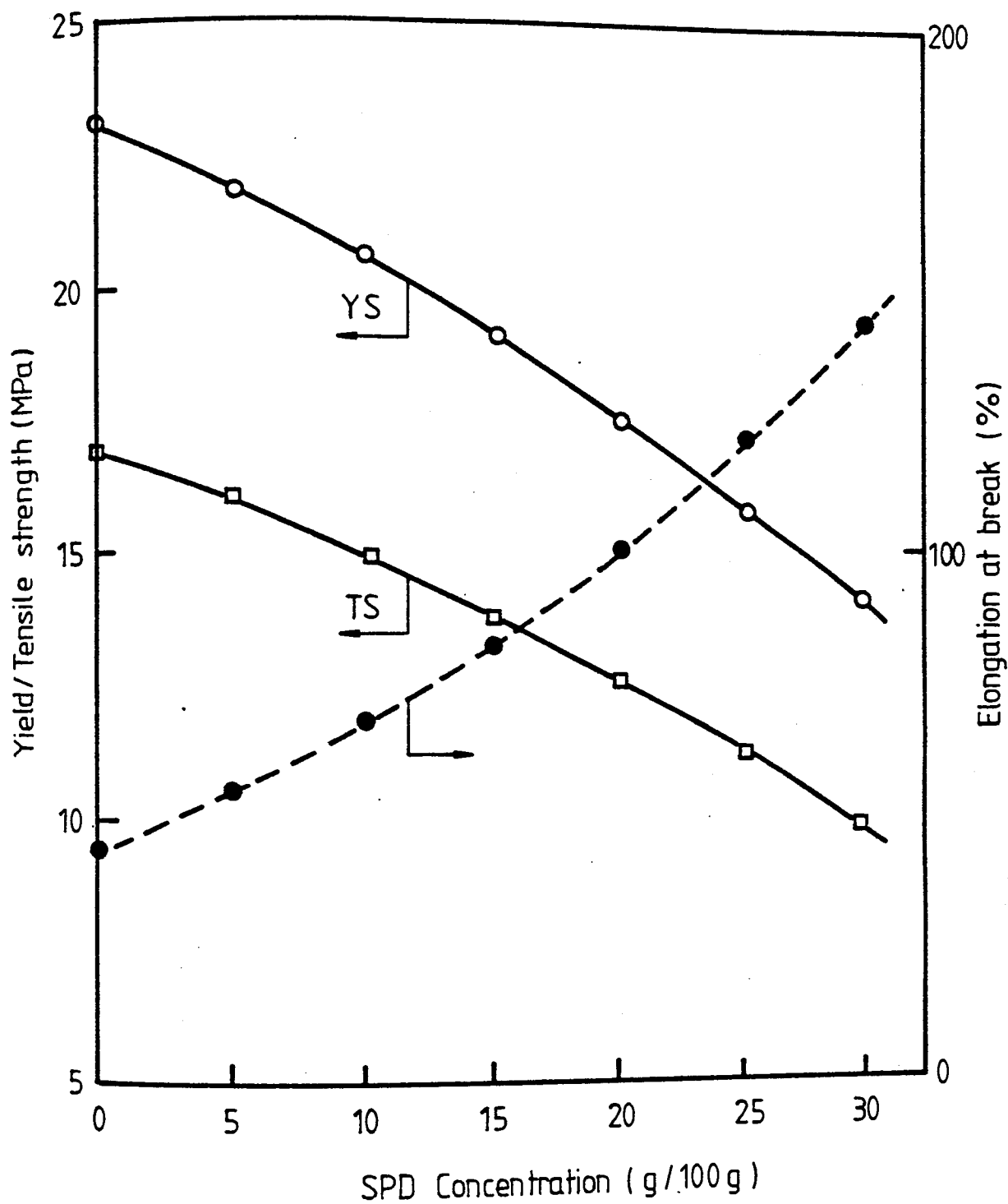

Figure 5.6 - Effect of NR/PP composition as SPD on the tensile properties of PP/PE(1:1) blends processed in Busko Kneader at 160°C (injection moulded samples).

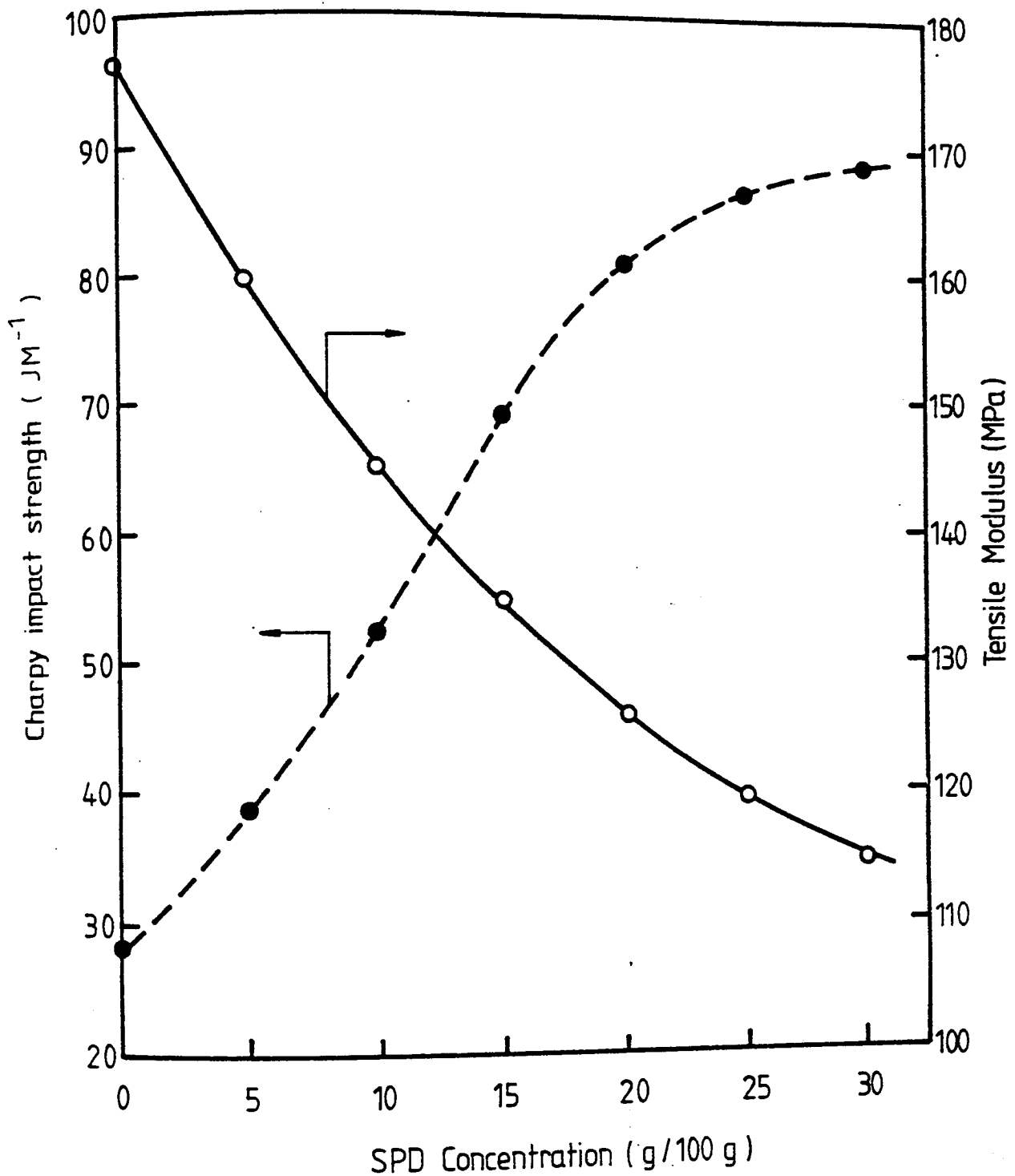

Figure 5.7 - Effect of NR/PP composition on the Charpy impact strength of PP/PE(1:1) blends processed in a Busko Kneader at 160°C (injection moulded samples).

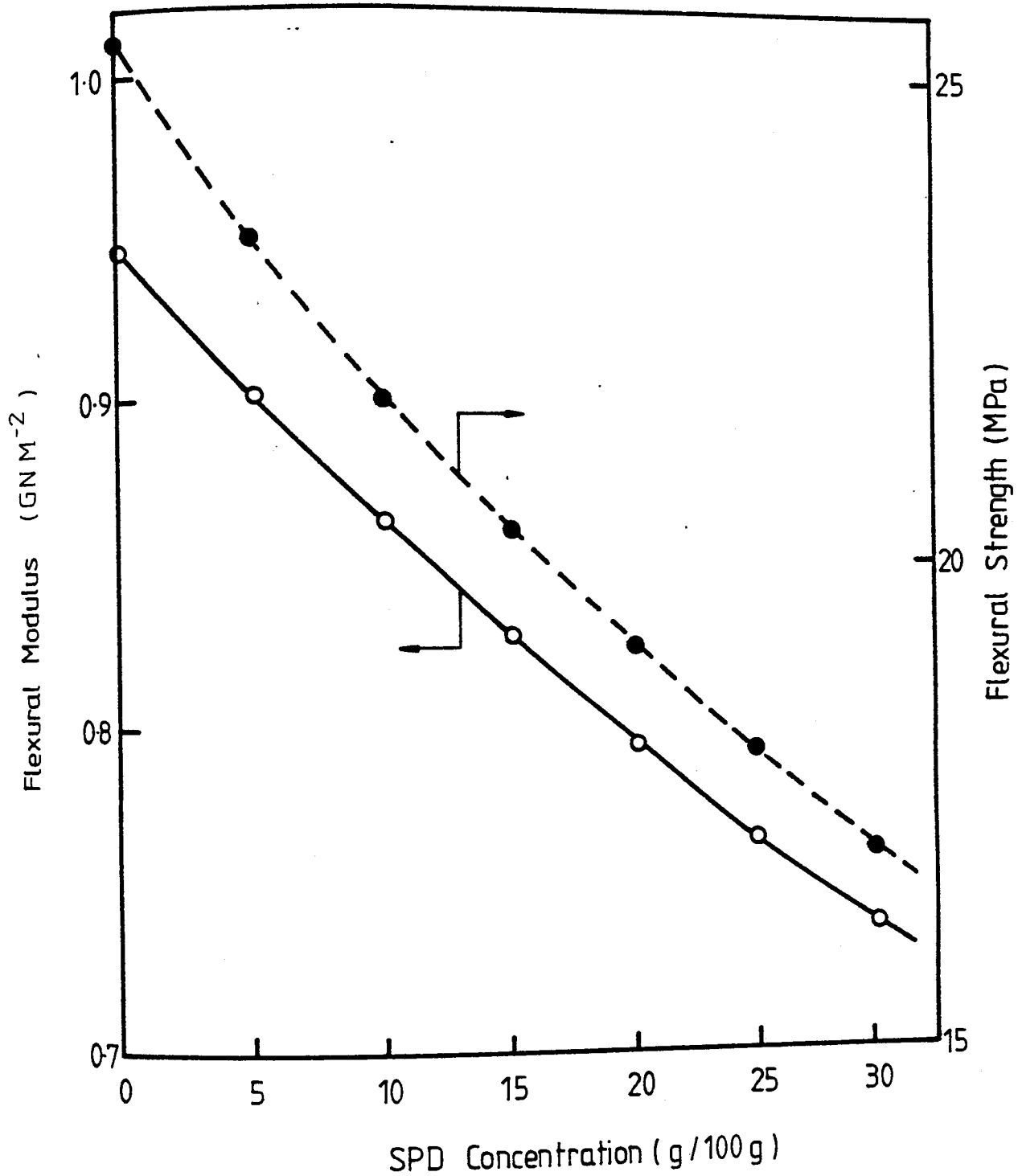

Figure 5.8 - Effect of NR/PP composition as SPD on the flexural modulus of PP/PE(1:1) blends processed in a Busko Kneader (injection moulded samples).

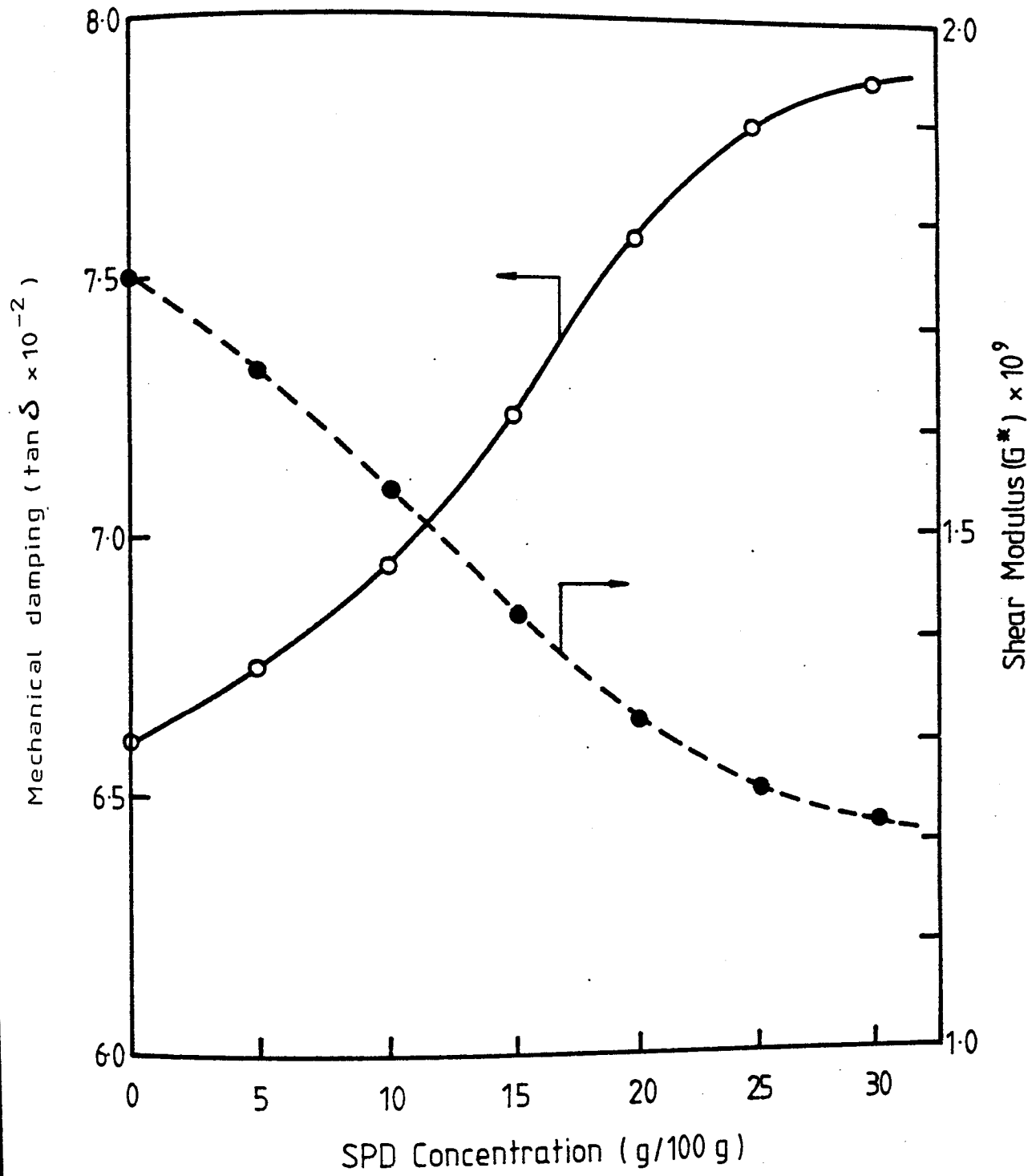

Figure 5.9 - Effect of NR/PP composition as SPD on the dynamic mechanical properties of PP/PE(1:1) blends processed in a Busko Kneader at 160°C (injection moulded samples)

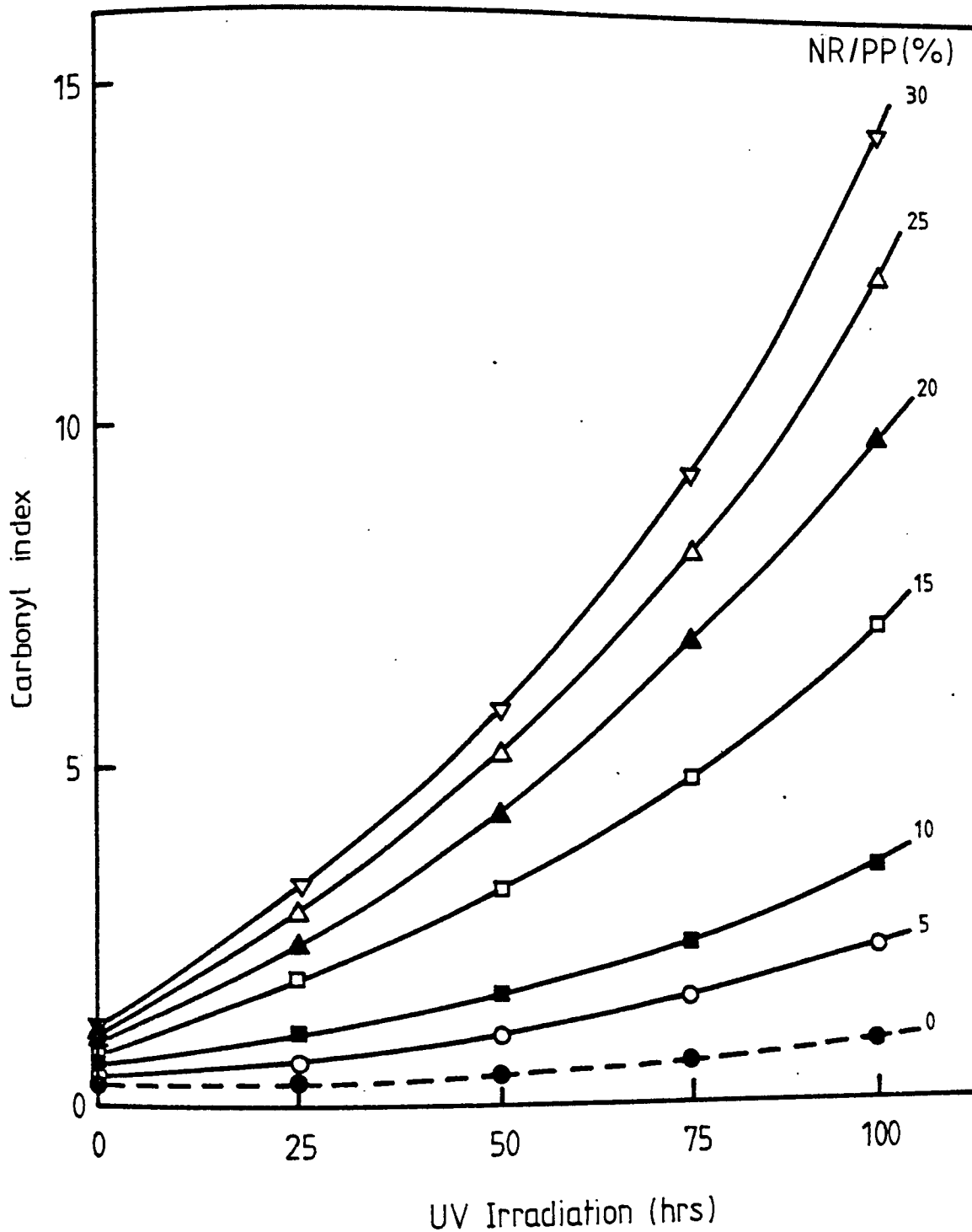

Figure 5.10 - Effect of TPNR composition as SPD on the photo-oxidation of films of PE/PP(1:1) blends during UV-irradiation (blends processed in a Brabender Torque rheometer at 180°C for 5 minutes) and numbers indicate the concentration of NR/PP in the blends).



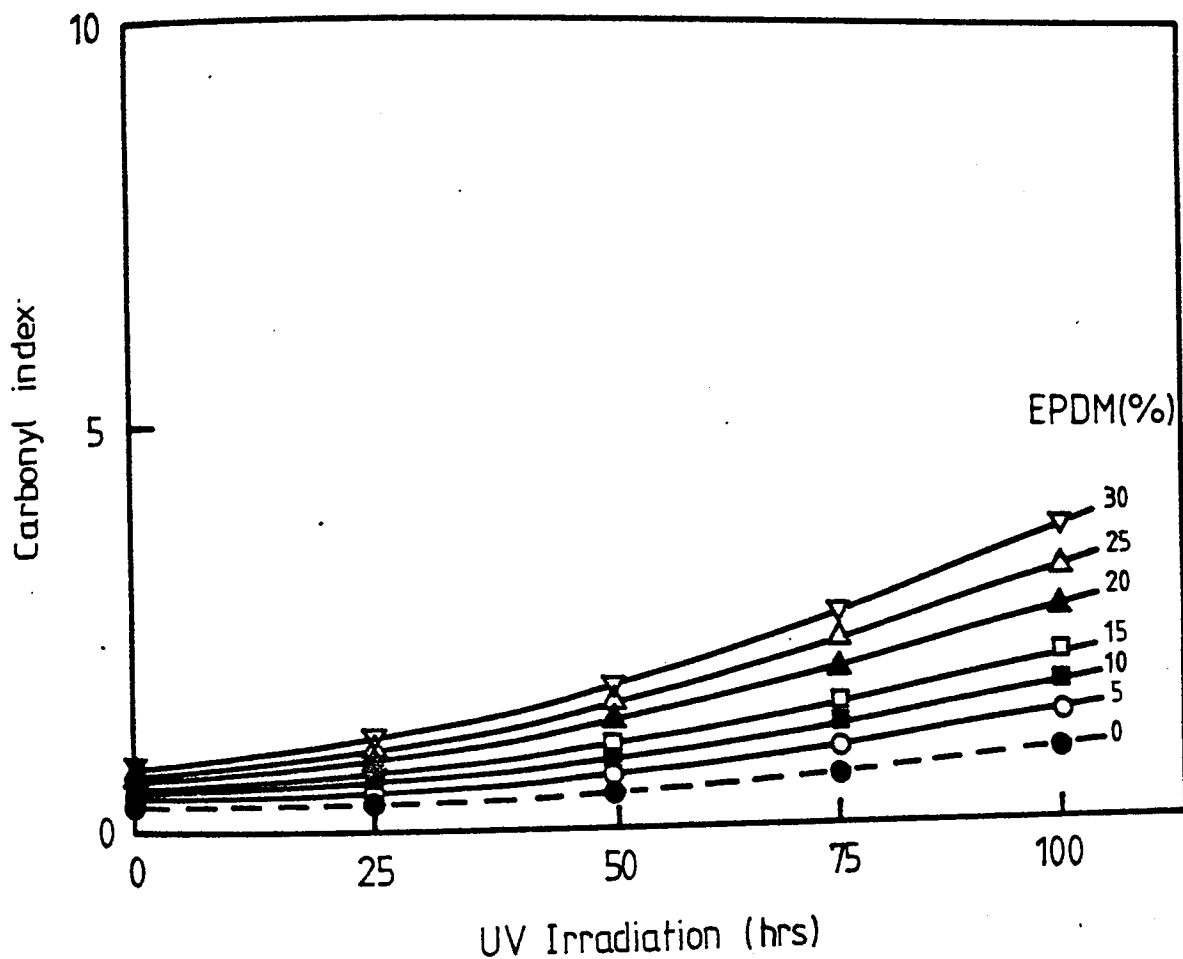

Figure 5.11 - Effect of EPDM as SPD on the photo-oxidation of films of PP/PE(1:1) blends during UV-irradiation (blends processed in a Brabender Torque rheometer at 180°C for 5 minutes) and numbers indicate the concentration of EPDM in the blends.

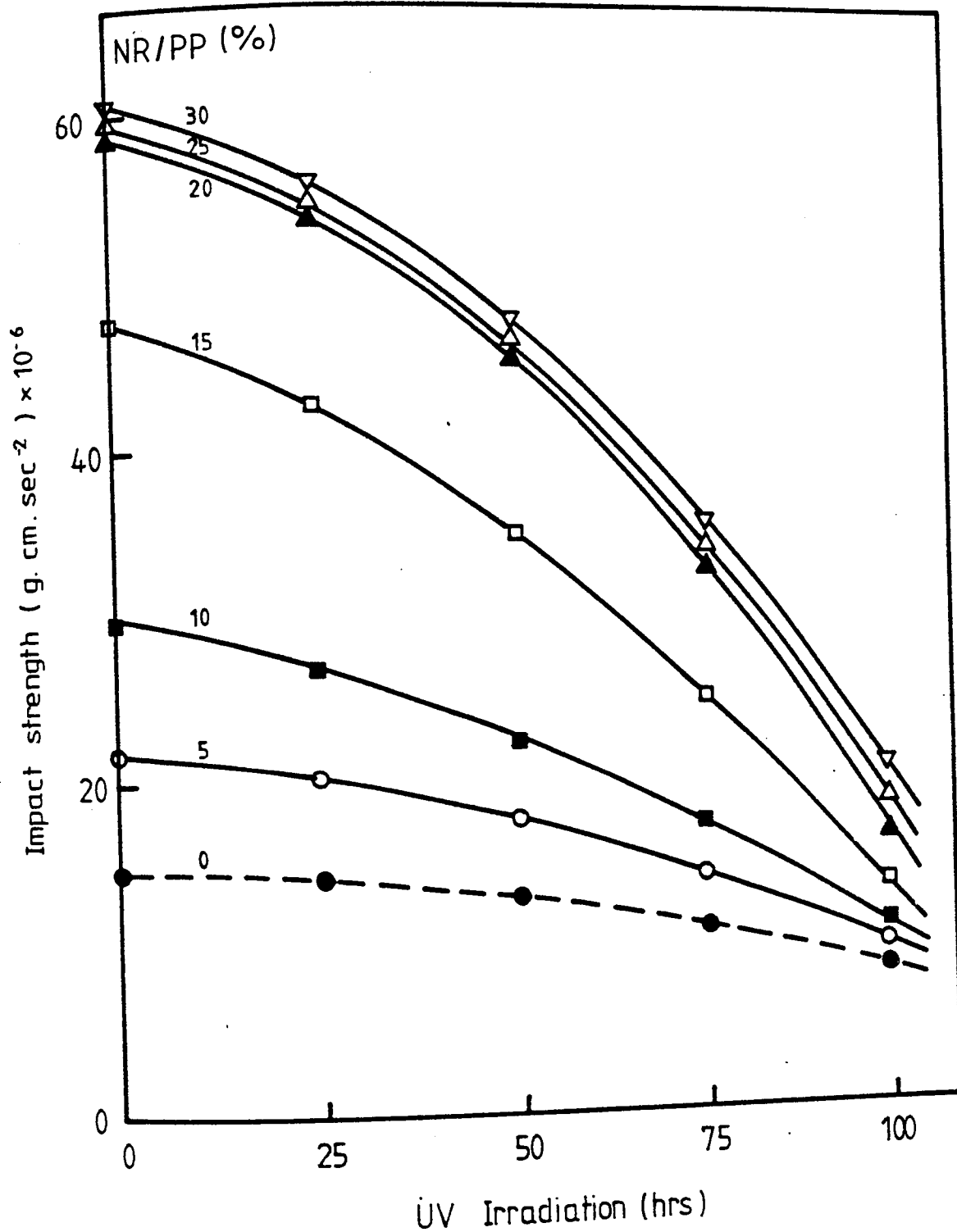

Figure 5.12 - Effect of TPNR as SPD on the impact strength of films of PE/PP(1:1) blends during UV-irradiation (blends processed in a Brabender Torque rheometer at 180°C for 5 minutes) and numbers indicate the concentration of NR/PP in the blends.

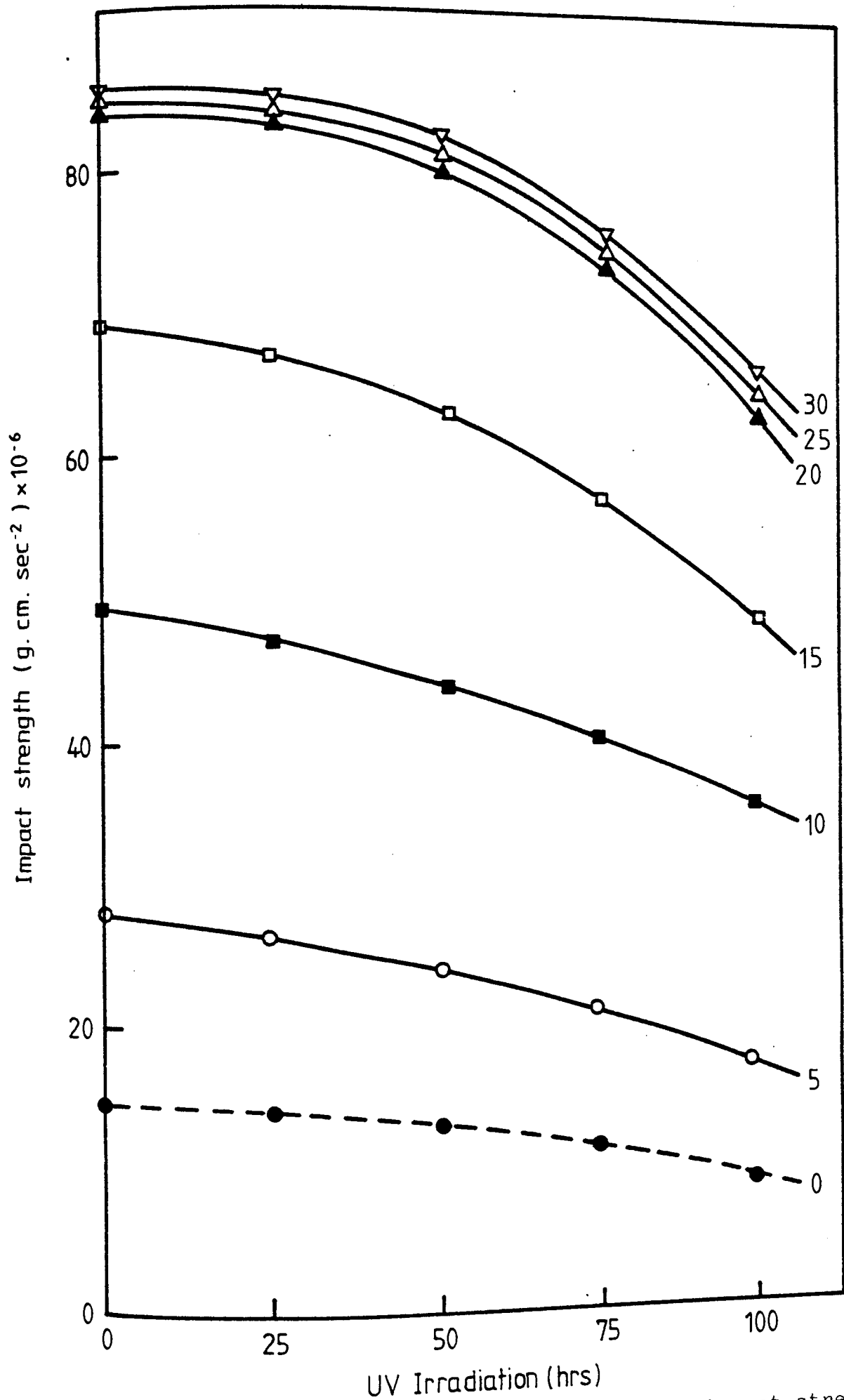

Figure 5.13 - Effect of EPDM as SPD on the impact strength of PE/PP(1:1) blends during UV-irradiation (blends processed in a Brabender Torque rheometer at 180°C for 5 minutes) and numbers indicate the concentration of EPDM in the

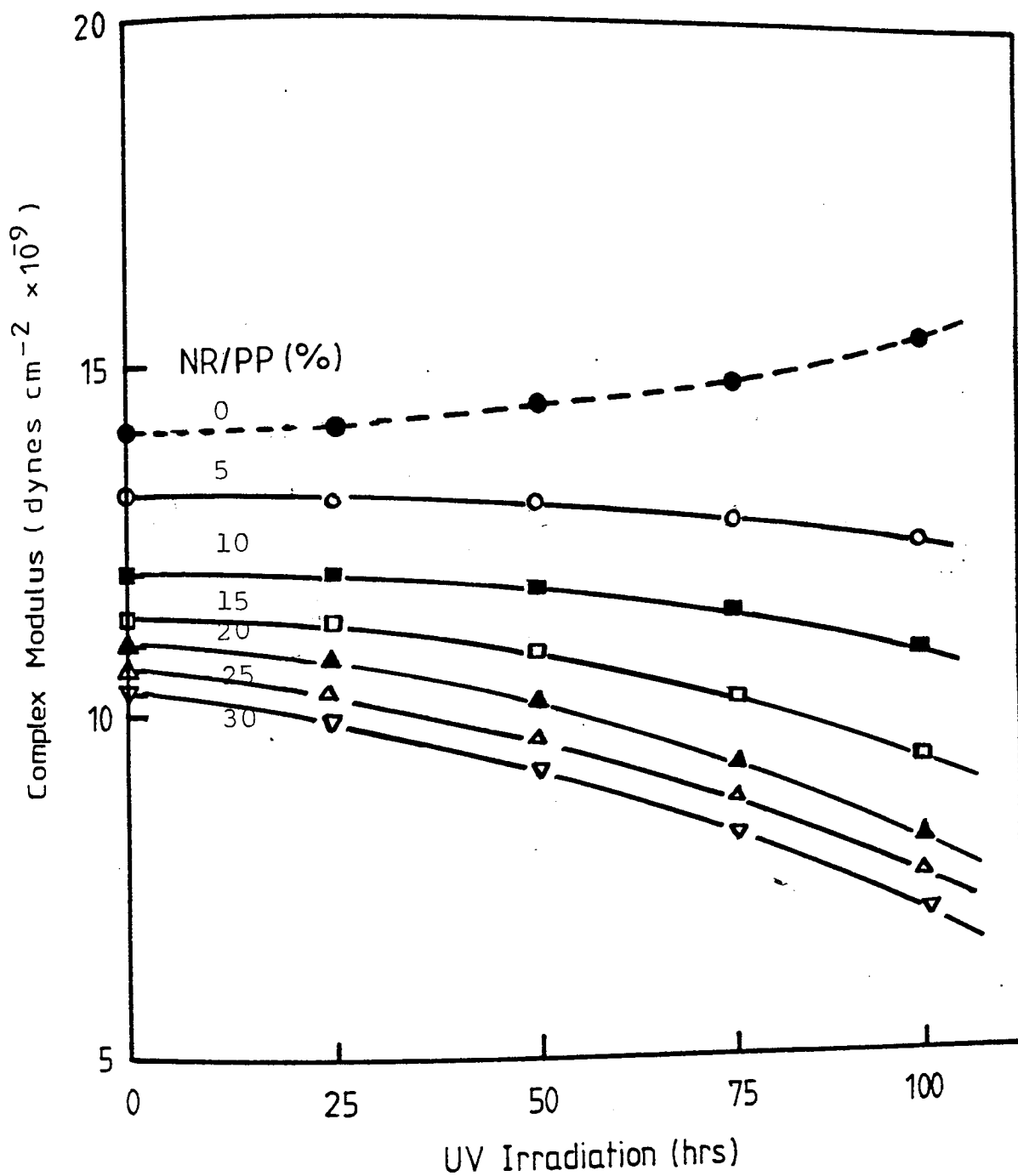

Figure 5.14 - Effect of TPNR as SPD on the complex modulus of films of PE/PP(1:1) blends during UV-irradiation (blends processed in a Brabender Torque rheometer at 180°C for 5 minutes) and numbers indicate the concentration of NR/PP in the blends.

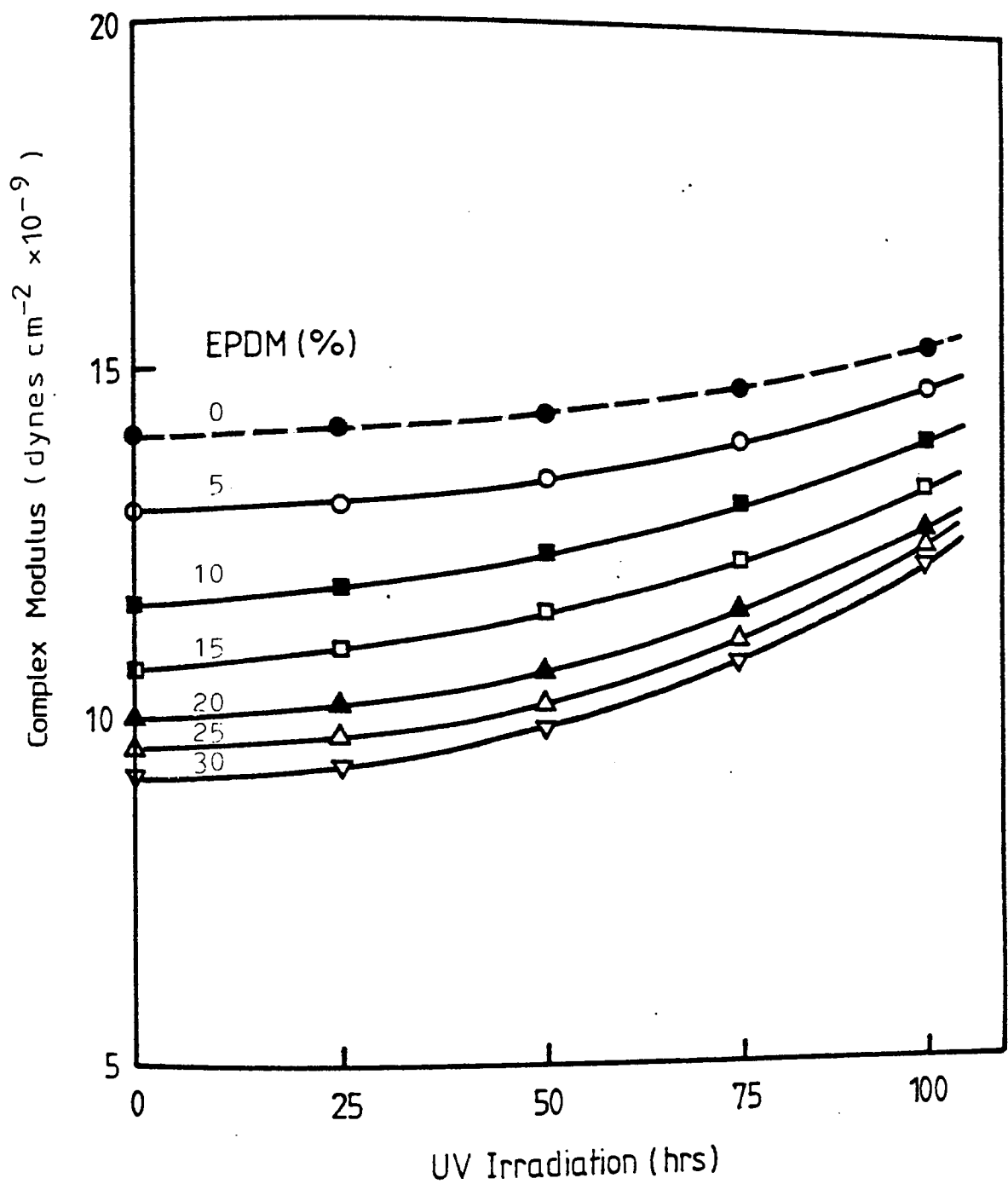

Figure 5,15 - Effect of EPDM as SPD on the complex modulus of PE/PP(1:1) blends during UV-irradiation (blends processed in a Brabender Torque rheometer at 180°C for 5 minutes) numbers indicate the concentration of EPDM in the blends.

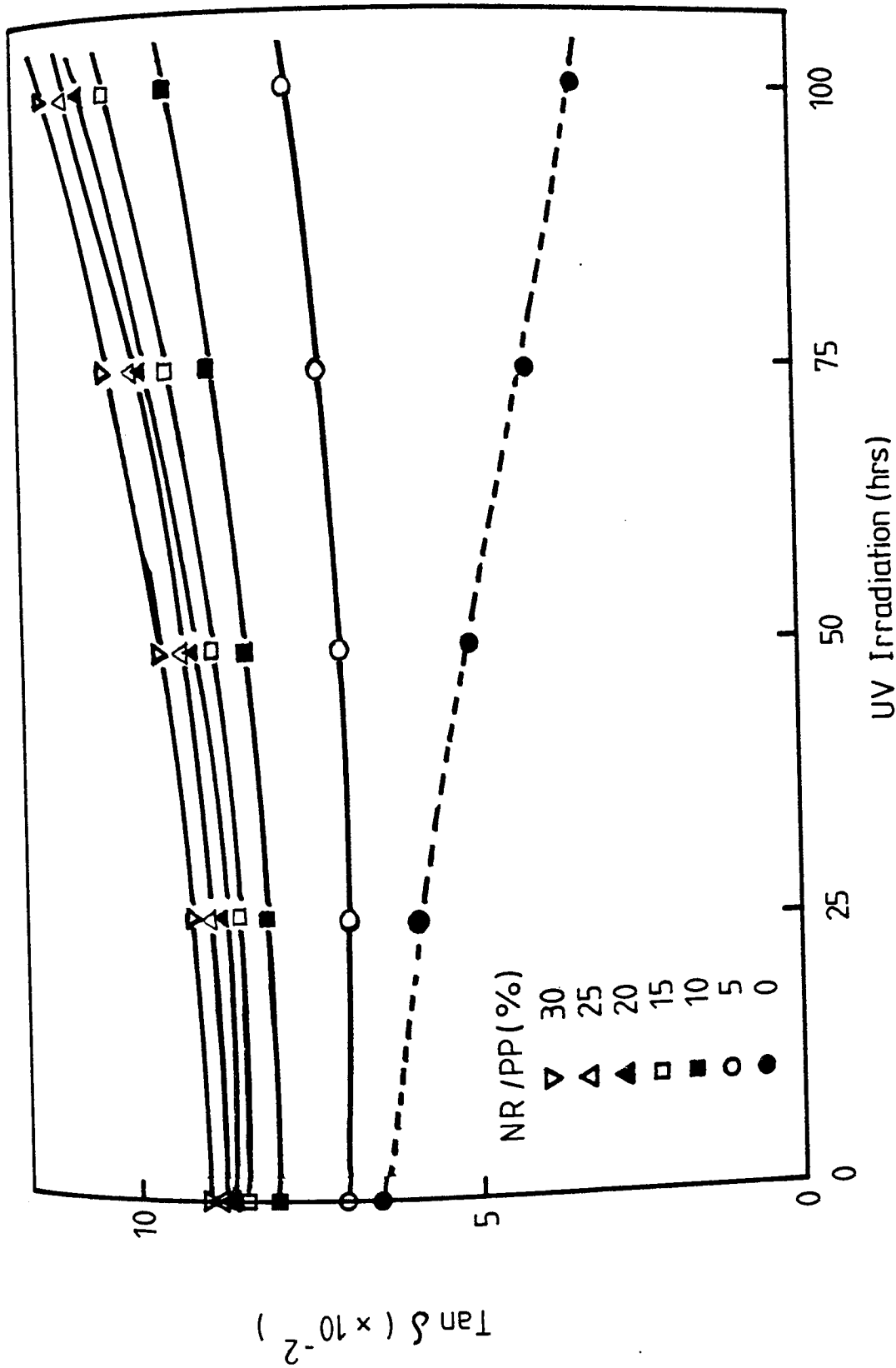

Figure 5.16 - Effect of NR/PP composition as SPD on the mechanical damping of PP/PE(1:1) blends during UV-irradiation (blends processed in a Brabender Torque rheometer at 180°C for 5 minutes). Numbers indicate the concentration of TPNR in the blends.

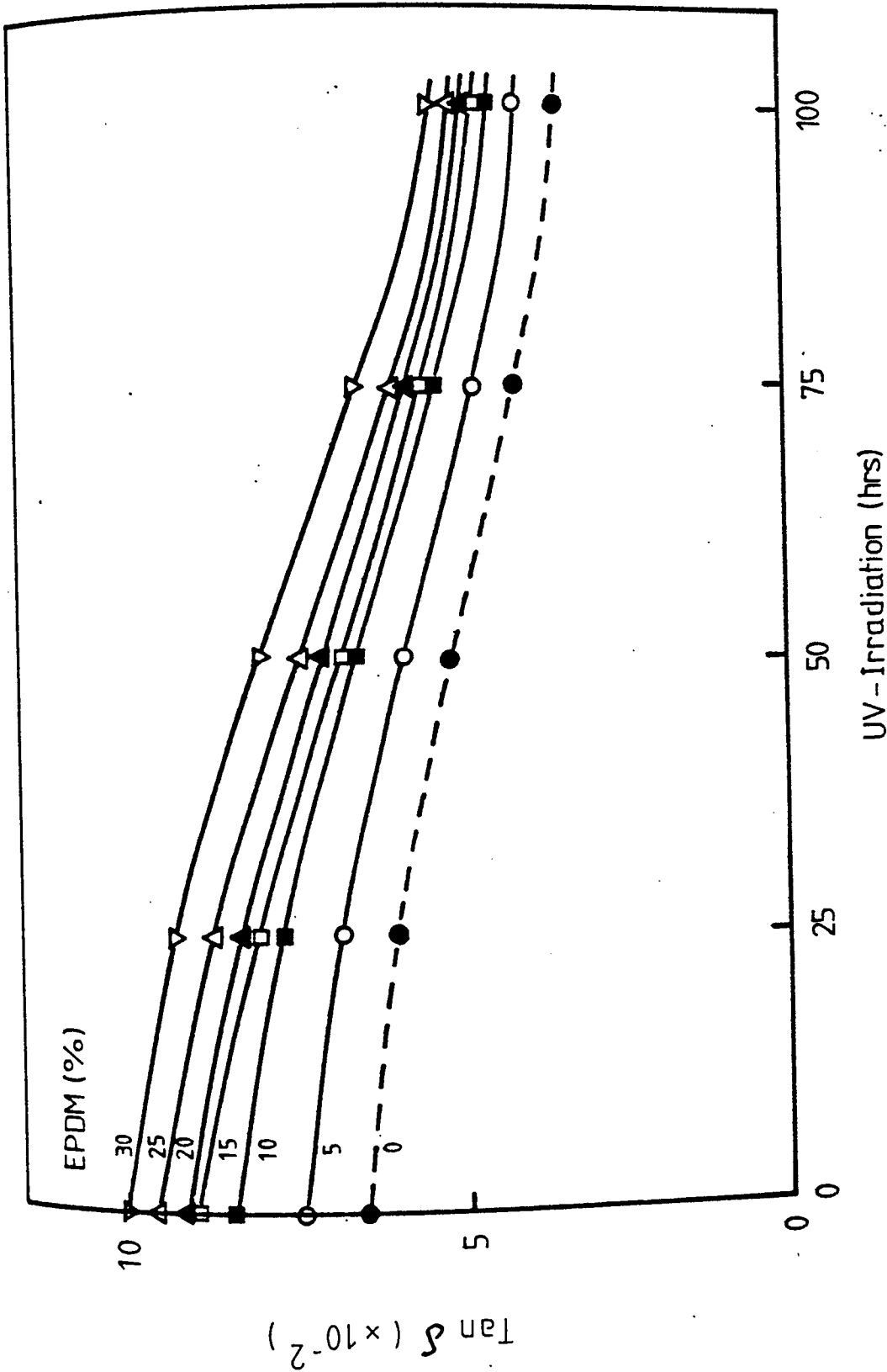

Figure 5.17 - Effect of EPDM as SPD on the mechanical damping ( $\tan \delta$ ) of PP/PE(1:1) blends during UV-irradiation (blends processed in a Brabender Torque rheometer at 180°C for 5 minutes) numbers indicate the concentration of EPDM in the blends.

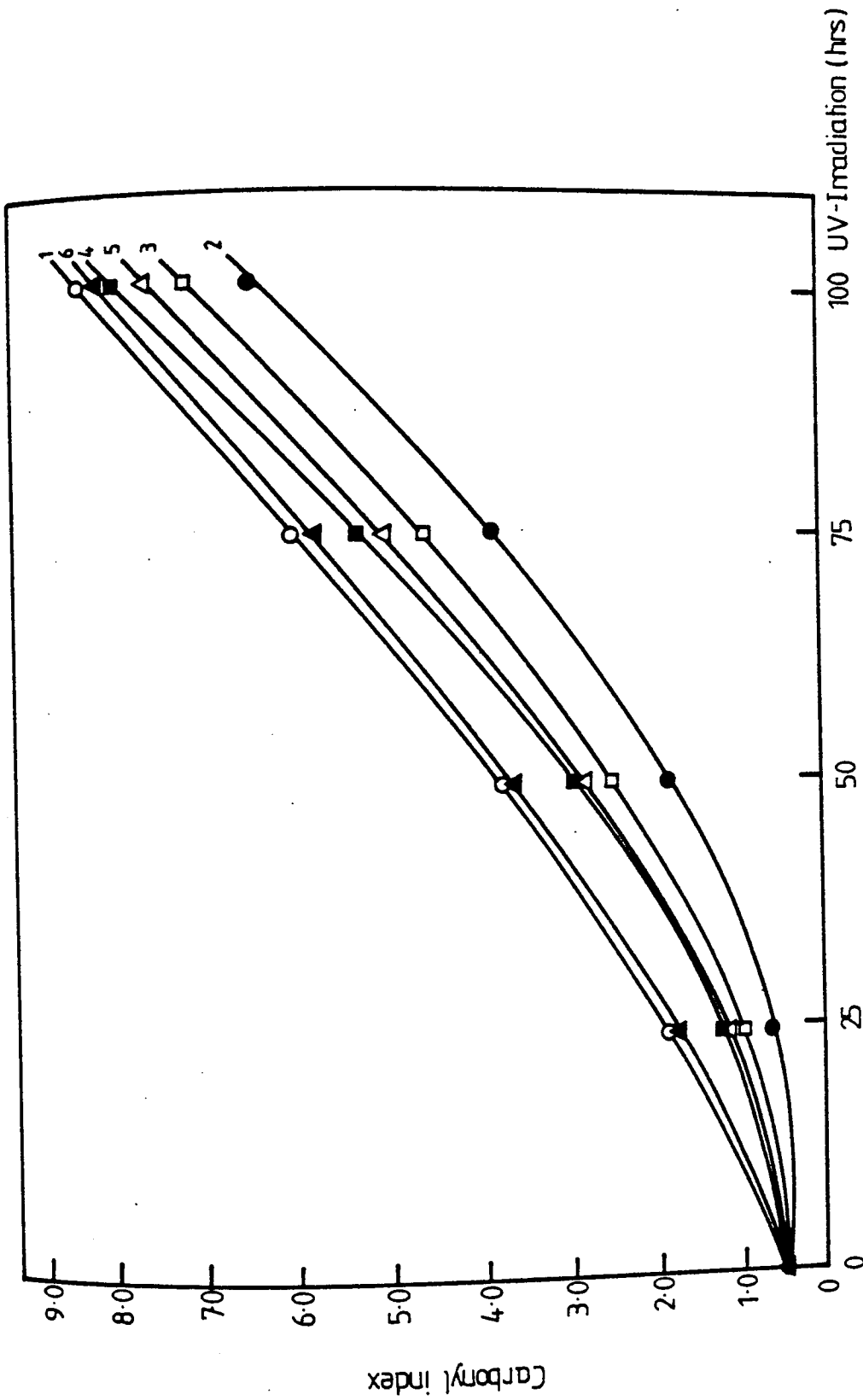

Figure 5.18 - Development of carbonyl groups during uv-irradiation of PP/PE/(NR/PP) blends (numbers indicate the stabiliser used) (Group I.1, Diagram 5.3).



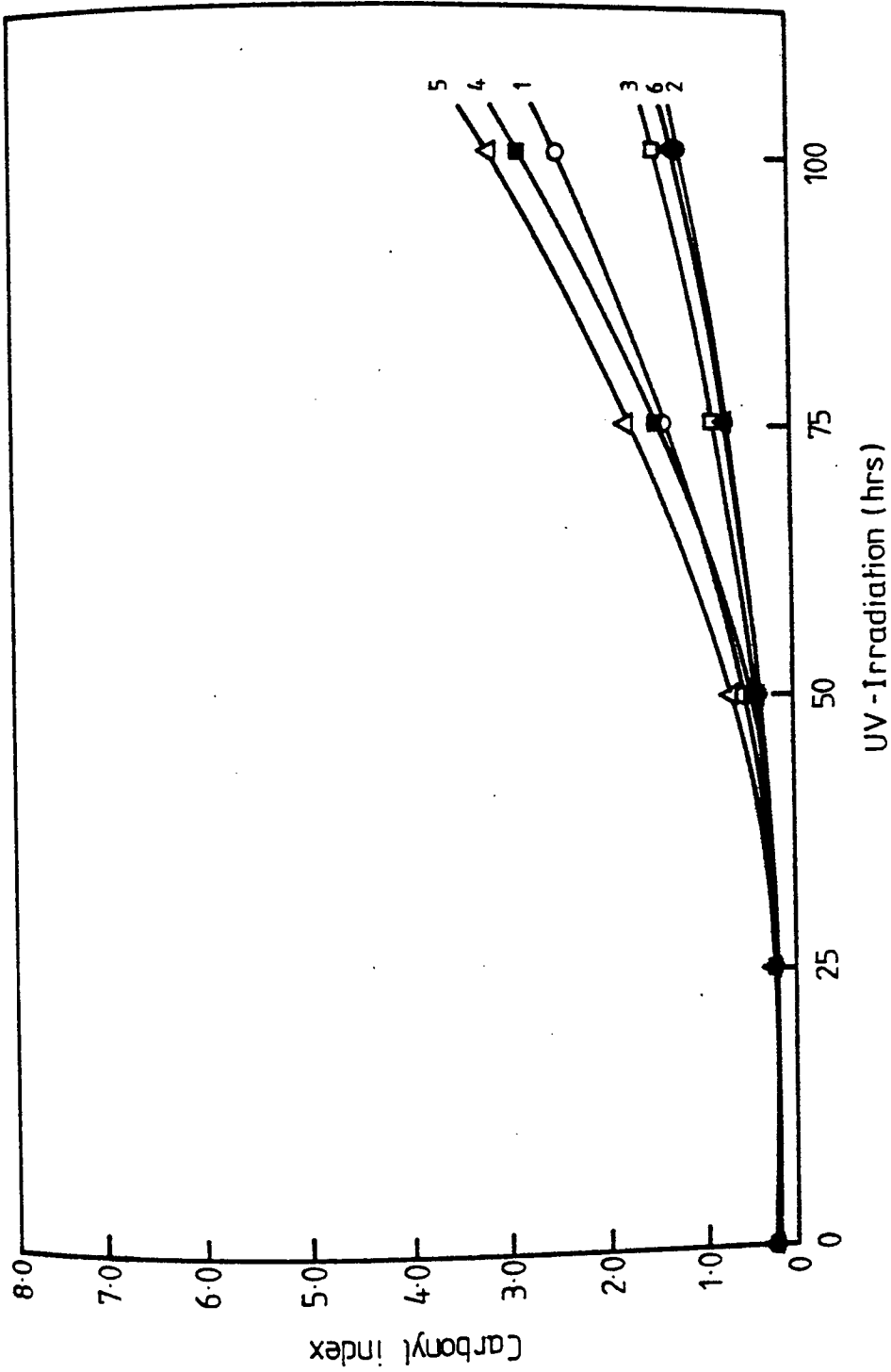

Figure 5.19 - Development of carbonyl groups during uv-irradiation of PP/PE/EPDM blends (numbers indicate the stabiliser used) (Group I.2, Diagram 5.4).

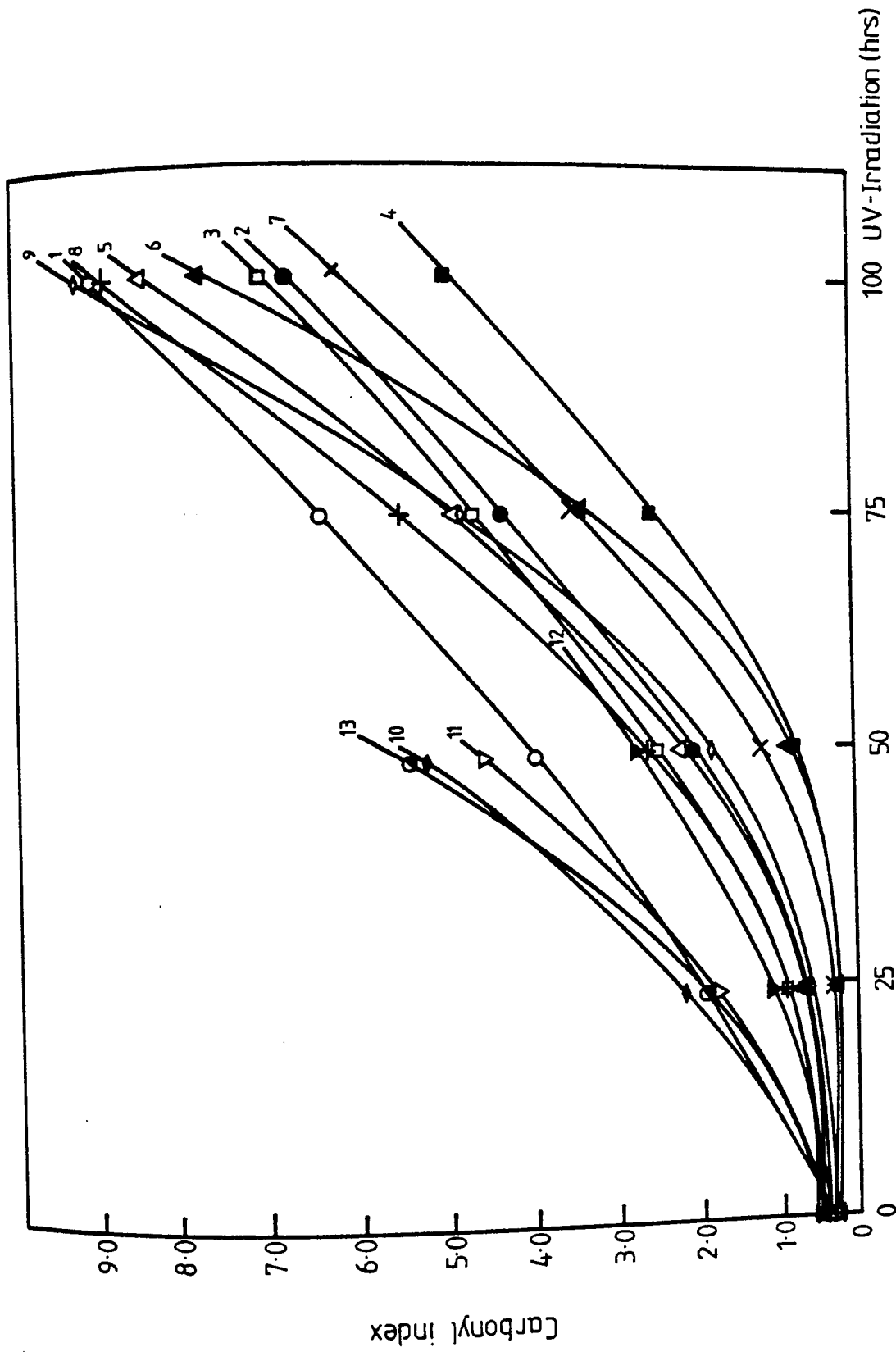

Figure 5.20 - Development of carbonyl groups during uv-irradiation of PP/PE/(NR/PP) blends (numbers indicate the stabiliser system used) (Group II.1; Diagram 5.5).

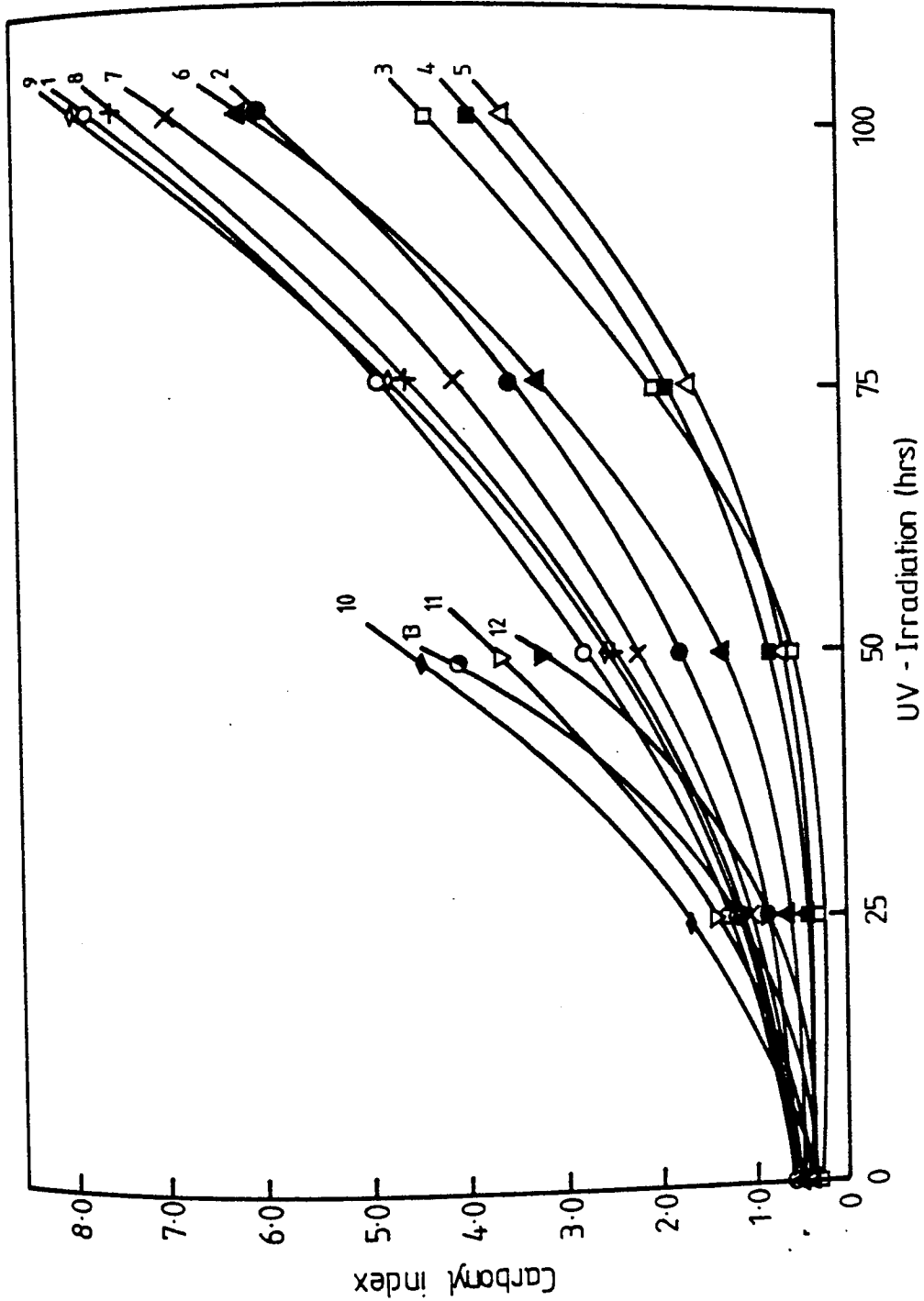

Figure 5.21 - Development of carbonyl groups during uv-irradiation of PP/PE/(NR/PP) blends. (numbers indicate the stabiliser system used) (Group II.2, Diagram 5.6).

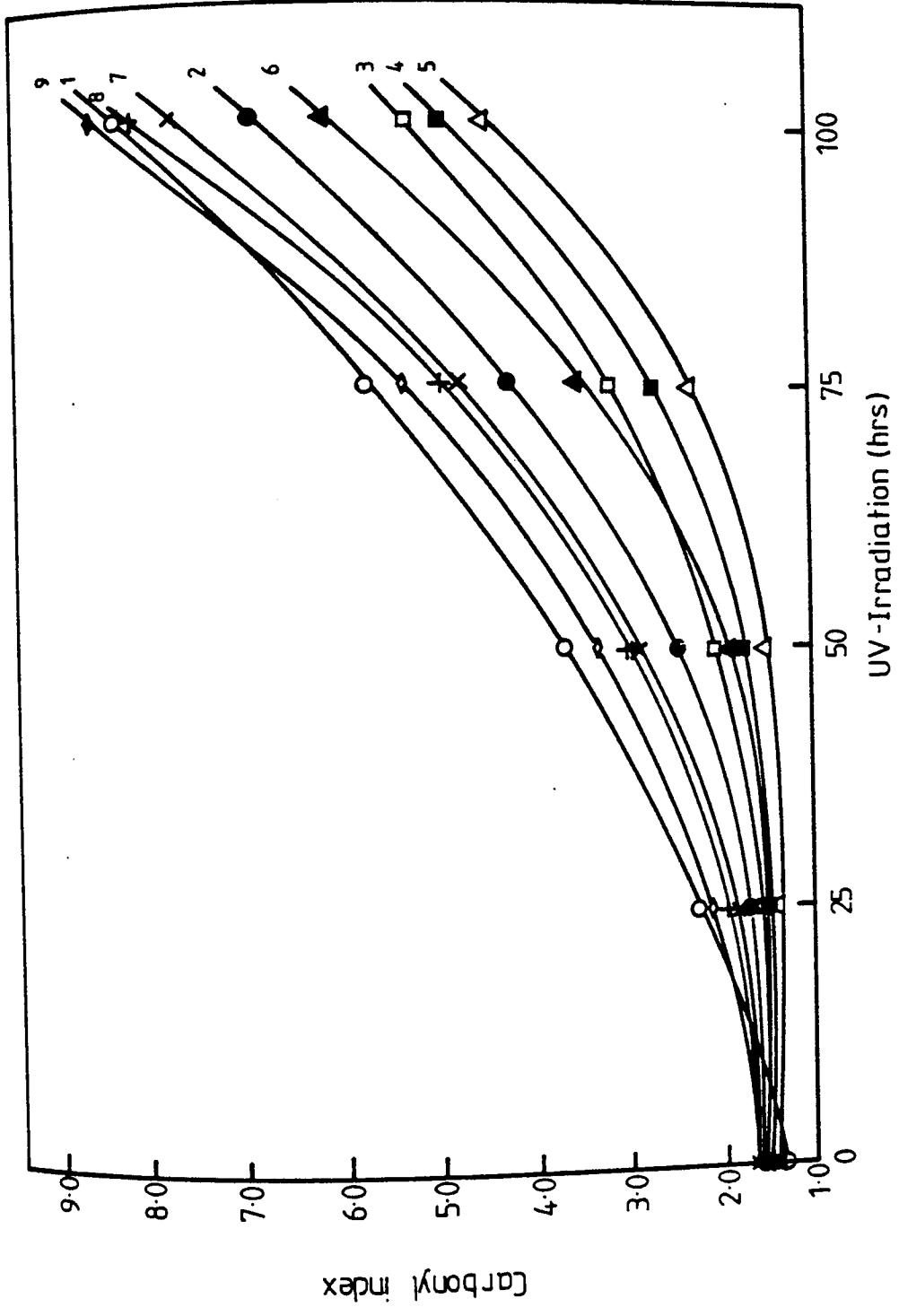

Figure 5.22 - Development of carbonyl groups during uv-irradiation of PP/PE/(NR/PP) blends (numbers indicate the stabiliser system used (Group II.3; Diagram 5.7)).

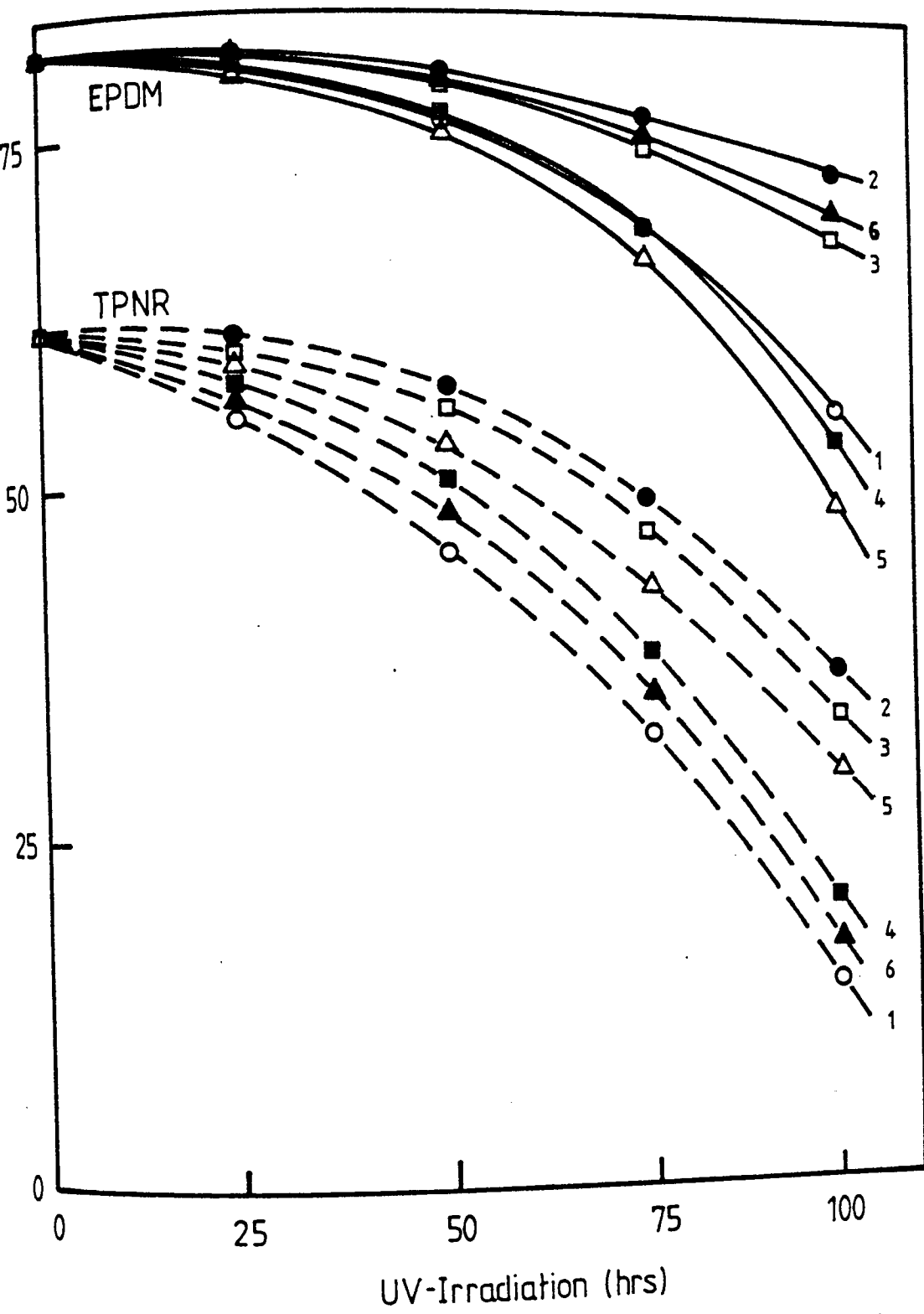

Figure 5.23 - Effect of uv-irradiation on the impact strength of PE/PP/SPD blends (numbers indicate the stabiliser used) (Group I.1, I.2; Diagram 5.3 and 5.4).

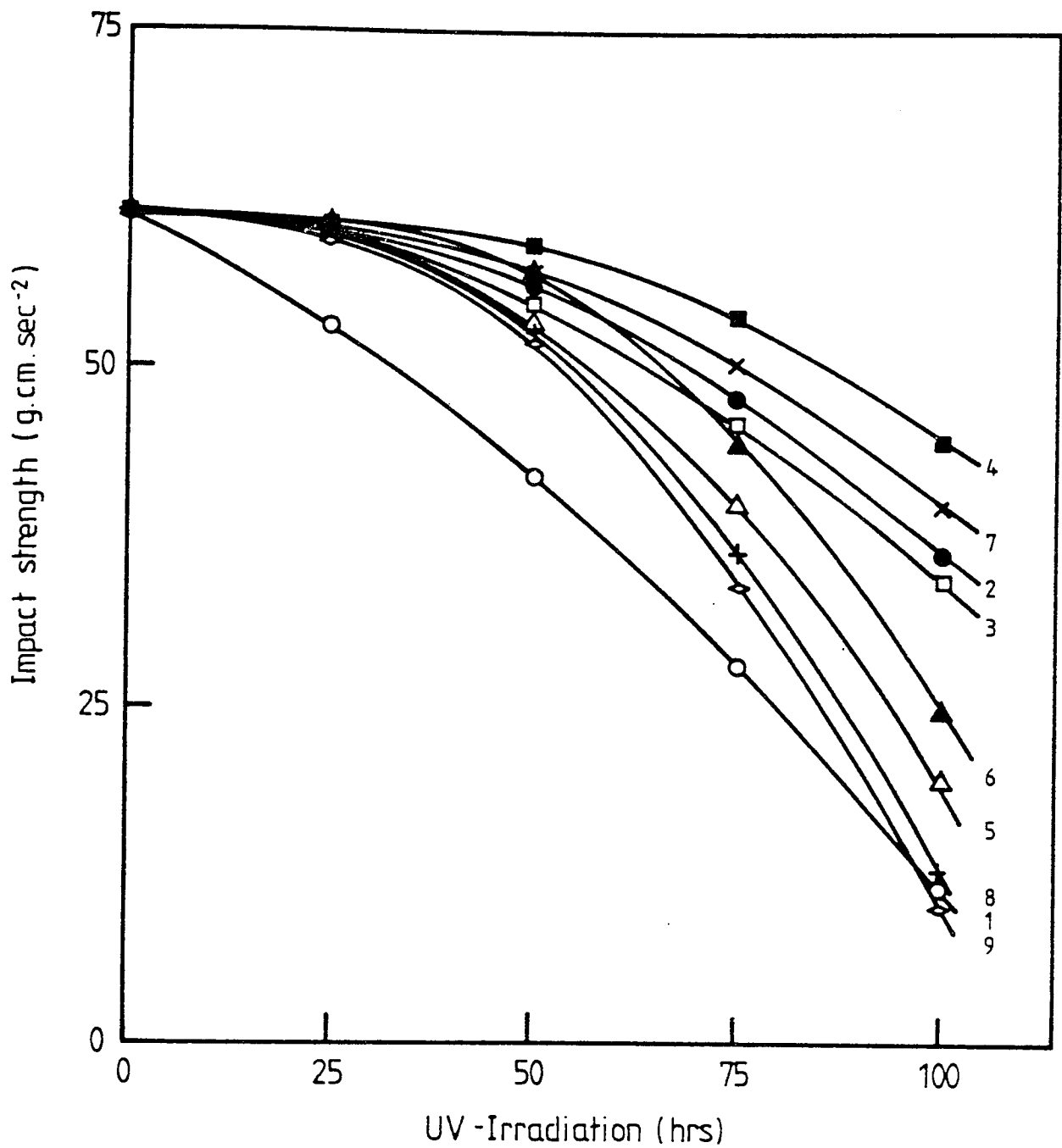

Figure 5.24 - Effect of uv-irradiation on the impact strength of PE/PP/(NR/PP) blends (Group II.1; Diagram 5.5).

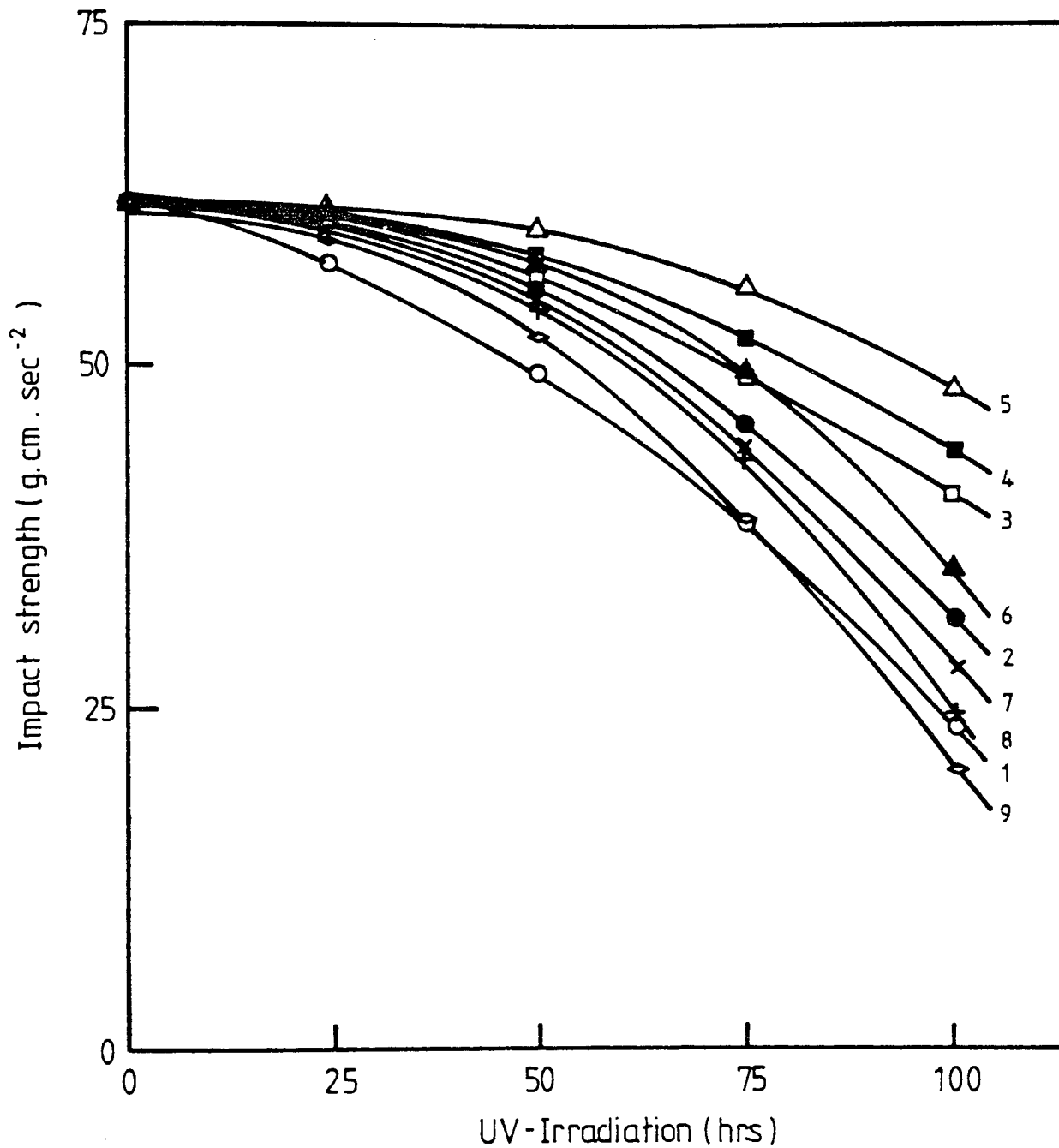

Figure 5.25 - Effect of uv-irradiation on the impact strength of PE/PP/(NR/PP) blends. (numbers indicate the stabiliser system used) (Group II.2; Diagram 5.6).

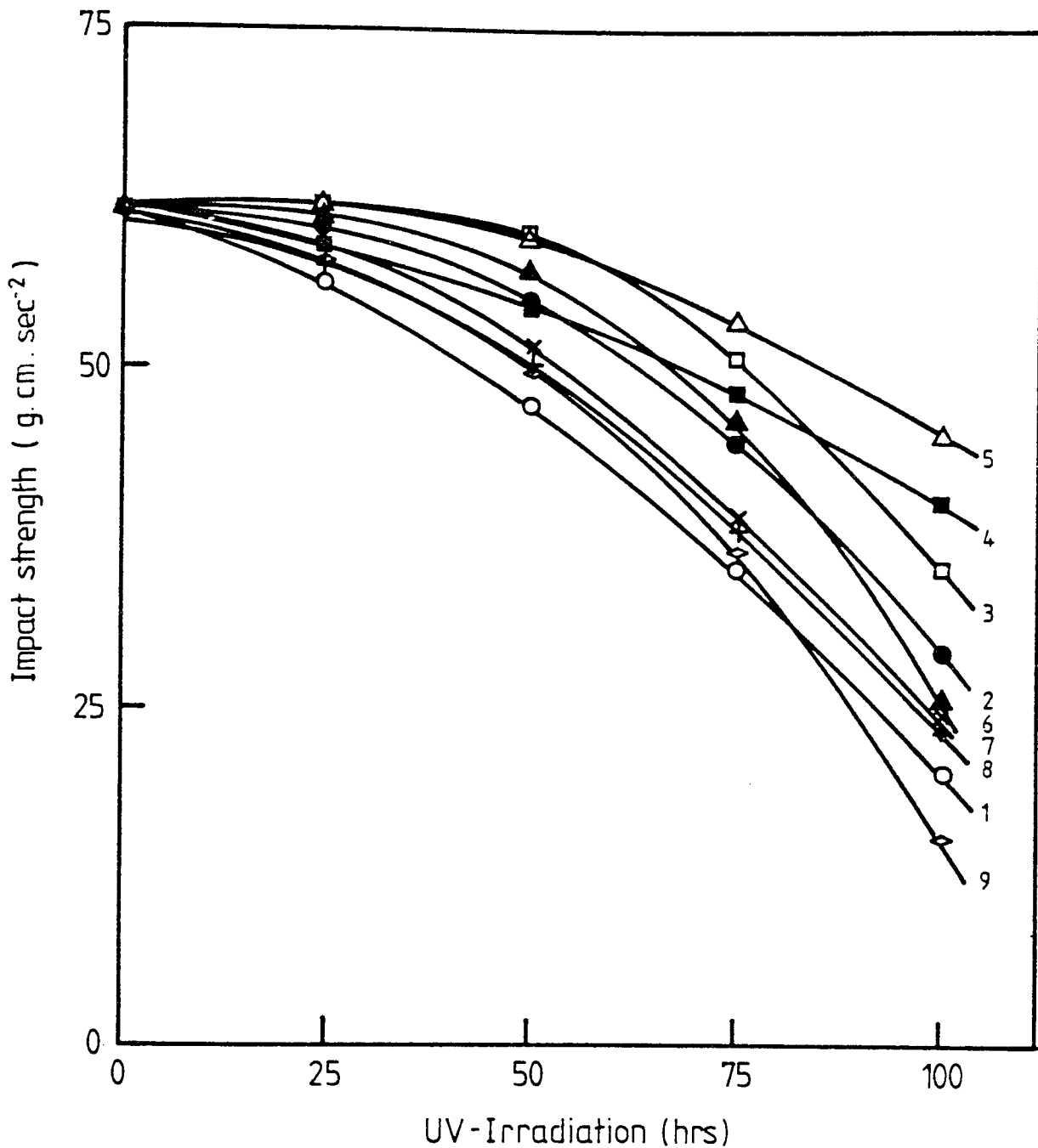

Figure 5.26 - Effect of uv-irradiation on the impact strength of PE/PP/(NR/PP) blends. (Numbers indicate the stabiliser systems used) (Group II.3; Diagram 5.7).



CHAPTER SIX

PREPARATION OF NATURAL RUBBER-POLYPROPYLENE BLENDS  
USING RECLAIM RUBBER AND ITS USAGE AS SOLID  
PHASE DISPERSANT IN PP/PE BLENDS

## 6.1 Objective

In this chapter, the possibility of using solid phase dispersant, SPD, which is made by replacing some of the fresh natural rubber by reclaim rubber, in NR/PP blends is investigated. The aims of this are two-fold; firstly: to find the optimal amount, when using reclaim rubber as part of the SPD, leading to blends having good overall properties, and secondly to study its effect, as solid phase dispersant (SPD), on the physical properties, thermal and photo-oxidative stabilities of PP/PE blends.

Typically NR/PP blends were prepared in a Brabender Torque rheometer at 160°C for 10 minutes in proportions of NR to PP of 60/40; 50/50; 40/60 and 30/70, and the ratios of fresh natural rubber to reclaim rubber were 100/0; 75/25; 50/50; 25/75 and 0/100 (Diagram 6.1). Prior to blending with polypropylene, fresh and reclaim rubber were masticated in an open two-roll mill at room temperature for 10 minutes (Diagram 6.1). Dicumyl peroxide was used for blends with a ratio of fresh rubber to reclaim rubber of 50/50 and the ratio of rubbers to polypropylene of 60/40. Film samples were prepared by compression moulding as described in Chapter 2, Section 2.2, and were tested for tensile properties, melt flow index and thermal stability (oven-ageing at 50°C and recompression moulding).

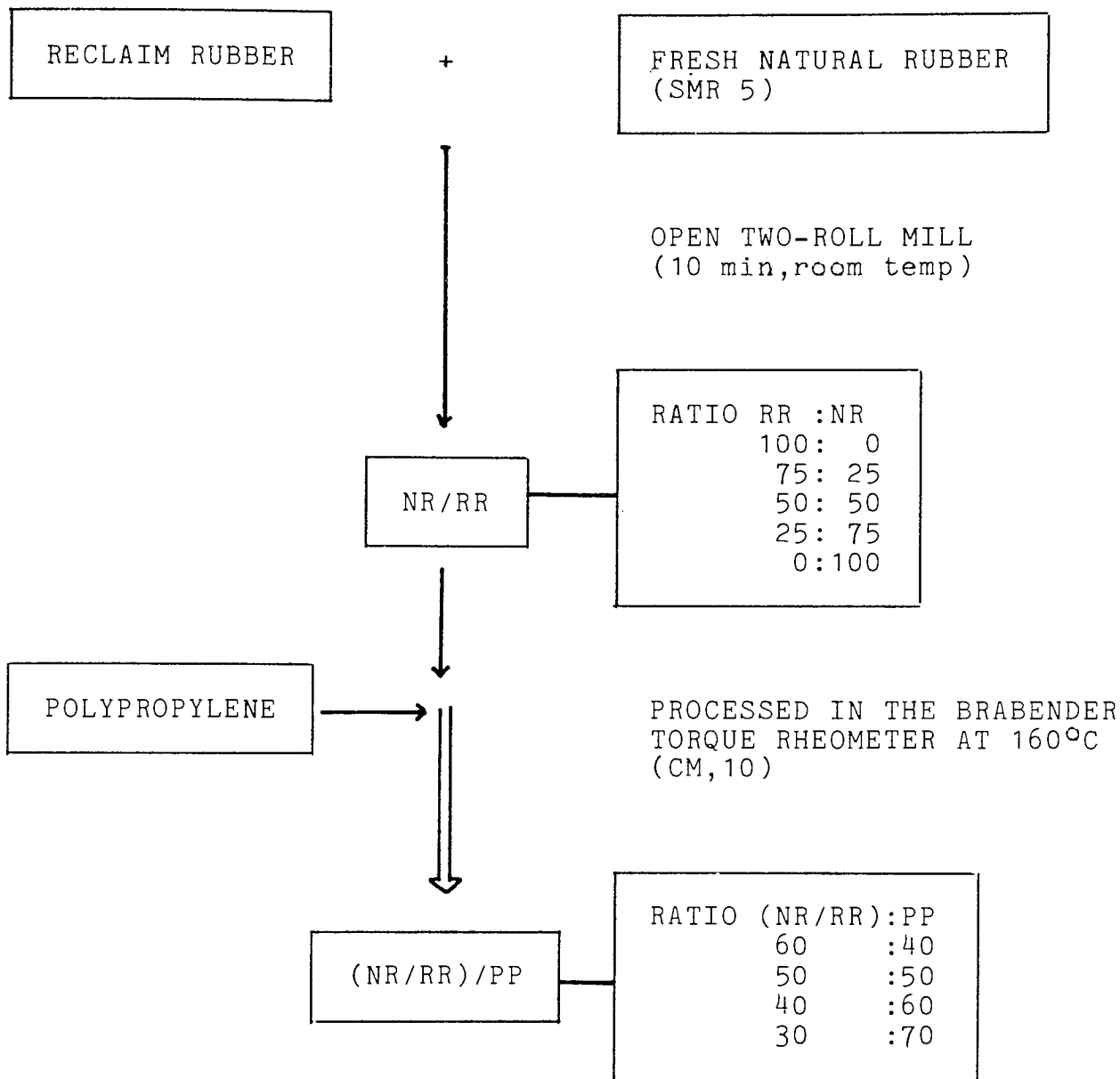

Diagram 6.1 Schematic operation of the preparation of (NR/RR)/PP blends

PP/PE/SPD ternary blends were prepared in a Brabender Torque rheometer at 180°C for 5 minutes (Diagram 6.2) as described in Chapter 5, Section 5.2. Film samples were prepared by injection moulding, and were tested for tensile properties, impact strength, dynamic mechanical properties and photo-oxidative stability.

## 6.2 Results and Discussion

### 6.2.1 Preparation of NR/PP Blends Containing Reclaim Rubber

#### 6.2.1.1 Effect of Reclaim Rubber on the Properties of NR/PP Blends

The variations of tensile strength and elongation at break of the NR/PP blends (without dicumyl peroxide) with the ratios of rubber to polypropylene and reclaim rubber to fresh rubber are shown in Figures 6.1 and 6.2. It is clear that tensile properties of blends containing 100 percent reclaim rubber are very inferior. This implies that reclaim rubber alone is not suitable for such blends. It has been shown<sup>(176- 178)</sup> that the addition of reclaim rubber in a conventional rubber compound always lowers the physical properties, e.g., tensile strength. Figure 6.3 shows the effect of reclaim rubber on the tensile properties of NR/PP (60/40) blends. It is interesting to note that properties remain almost unaffected by replacing up to 50% of fresh rubber by reclaim rubber, after which properties decay

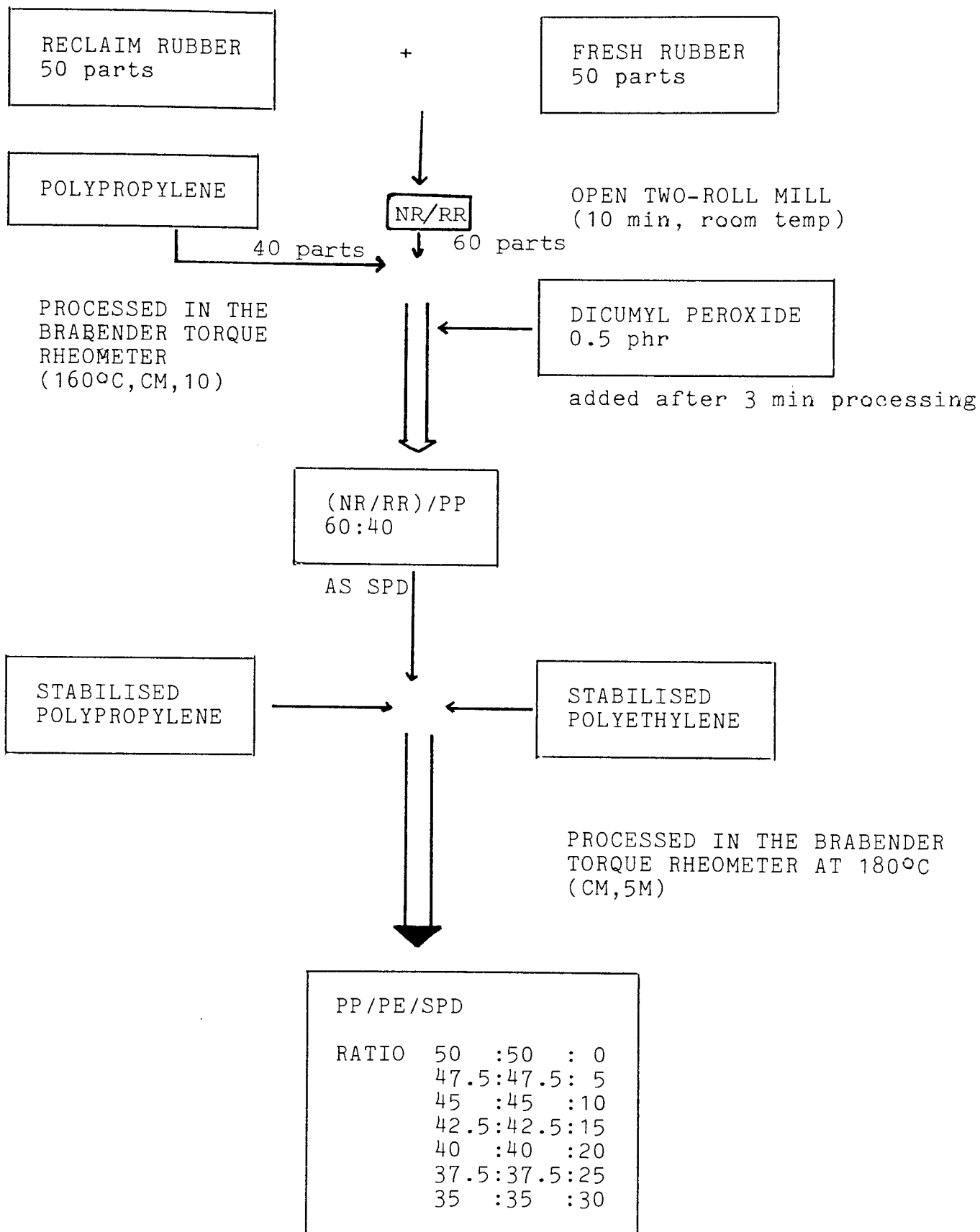

Diagram 6.2 Schematic operation in the preparation of PP/PE/SPD ternary blends

significantly. While tensile strength and elongation decrease with increasing concentration of reclaim rubber, tensile modulus increases (Figure 6.3). This may be due to a weak adhesion between phases in (NR/RR)/PP blend which undergo failure easily<sup>(179)</sup>. Based on these results, it is clear that the replacement of half of the fresh rubber by reclaim rubber (ratio NR:RR of 50:50) in the NR/PP blends does not affect the properties of the blends adversely. The presence of such amounts of reclaim rubber may reinforce the blend due to the presence of vulcanised rubber and added compounding ingredients in the reclaim rubber. Further replacement of fresh rubber by reclaim rubber (RR>PP) results in deterioration in properties of (NR/RR)/PP blends (Figure 6.3).

#### 6.2.1.2 Effect of Dicumyl Peroxide on the Properties of (NR/RR)/PP Blends

Figure 6.4 shows the effect of dicumyl peroxide concentration on the tensile properties of (NR/RR)/PP blends containing 50/50 NR/RR. It is clear that tensile strength increases with increasing concentration of dicumyl peroxide up to 0.5 phr, while elongation at break decreases commensurately. Tensile modulus of the above blends also increases with increasing concentration of dicumyl peroxide (Figure 6.5). However, melt flow index decreases dramatically. This may be due to a "revulcanisation process"<sup>(179)</sup> which occurs in the reclaim rubber phase, since it is known

that reclaim rubber contains chemical ingredients which, in turn, can react with the peroxide to form a vulcanised rubber. In comparison with the corresponding blends containing 100 percent fresh rubber (Figure 6.4 inset), the trend of improvement in tensile strength, for example, is quite different. In these blends, tensile strength increases with increasing concentration of dicumyl peroxide up to 0.5 phr, after which no significant change is observed (Figure 6.4), while for blends containing 100 percent fresh rubber (inset), the tensile strength increases to reach a maximum at a concentration of dicumyl peroxide of 0.3 phr followed by a dramatic decrease with any further increase in dicumyl peroxide concentration. The trend of decrease in MFI is similar but the magnitude of decrease in blend containing reclaim rubber (Figure 6.5) is lower than that of corresponding blends containing no reclaim rubber (Figure 6.5 inset). This may suggest that dicumyl peroxide reacts efficiently with the rubber phase (preferably reclaim rubber) rather than with polypropylene phase which in turn causes degradation (Chapter 3, Scheme 3.1) and hence has deleterious effects on subsequent physical properties. Furthermore, the reclaim rubber may act as a radical trap due to the presence of carbon black<sup>(180)</sup> and antioxidants in the reclaim rubber phase.

### 6.2.1.3 Thermal-oxidative Stability of NR/PP Blends

#### Containing 50/50 NR/RR

Tensile properties examination of NR/PP blends containing

50/50 NR/RR during oven-ageing at 50°C (Figure 6.6) reveals that these blends have a quite good thermal stability under these conditions. The tensile strength, modulus and elongation at break remain almost unaffected after 7 days of ageing. The effect of re-compression moulding at 180°C on the tensile properties of the blends is shown in Figure 6.7. It is clear that up to 5 times re-compression moulding, the blends retain their tensile properties, but further re-compression moulding causes deterioration in tensile properties. This may suggest that at higher temperature (180°C), thermooxidative stability of these blends becomes less. Comparison of Figure 6.7 and Figure 4.11 shows clearly that replacement of fresh rubber by reclaim rubber and its use with PP (at ratio of rubbers to PP of 60:40) is advantageous since in both cases (i.e., use of 100% fresh rubber or partially replacing it by reclaim rubber), tensile properties are retained after 5 times re-compression moulding operation.

#### 6.2.2. Effect of (NR/RR)/PP as Solid Phase Dispersant (SPD) on Properties of PP/PE Blends

Examination of tensile properties of PP/PE blends in the presence of SPD at various concentrations of SPD [(NR/RR)/PP] is shown in Figure 6.8 (see Diagram 6.2). It is clear that tensile strength and tensile modulus decrease with increasing concentration of (NR/RR)/PP, while the elongation at break increases commensurately. This must be due to the rubber



content of (NR/RR)/PP which increases the flexibility of the PP/PE blends in a way similar to that shown for EPDM and (NR/PP) (see Chapter 5, Figures 5.1 to 5.3). The rubber particles increase the molecular mobility of the matrix (i.e., PP/PE chains) when an internal stress is applied. Dynamic mechanical properties of these blends shown in Figure 6.9 also reveals that as the concentration of (NR/RR)/PP increases, mechanical damping ( $\tan \delta$  at 20°C) increases and concomitantly complex modulus decreases. This indicates that (NR/RR)/PP does modify the viscoelasticity of the thermoplastic blend (PP/PE) in the same way as shown for NR/PP and EPDM which must be due to the rubber content.

Toughness of PP/PE blends is increased as the concentration of (NR/RR)/PP increases (Figure 6.10). This again is due to the rubber phase in the (NR/RR)/PP which absorbs and dissipates external energy during impact<sup>(154,158)</sup>. The impact strength levels off after the concentration of 20 percent by weight of [(NR/RR)/PP], which was also found in the previous chapter (see Chapter 5, Figure 5.3). Therefore, 20 percent weight concentration of [(NR/RR)/PP] is used for further experiments as SPD, improving toughness of PP/PE blends without sacrificing any further tensile properties e.g., tensile strength and modulus.

Figures 6.11 and 6.12 summarise the properties of PP/PE/SPD (40:40:20) ternary blends with different SPD's (EPDM, NR/PP and (NR/RR)/PP) in comparison with PP/PE blend without SPD

(control). It is clear that 20 parts of NR/PP and (NR/RR)/PP incorporated into PP/PE blends causes a higher reduction in the tensile strength when compared to the case of EPDM, whereas, the elongation to break of those blends increases. This must be attributed to the higher level of PP contributed from NR/PP or (NR/RR)/PP. Tensile modulus of PP/PE blend decreases as 20 parts of SPD is added. The decrease in tensile modulus due to the addition of (NR/RR)/PP is lower than the corresponding blend containing EPDM or NR/PP. This may be due to the presence of reclaim rubber which contains vulcanised rubber particles and filler. It was found that carbon black increases the tensile modulus of NR/PP blends (see also Chapter 4, Section 4.2.1). Dynamic mechanical properties of PP/PE blend are also affected by the incorporation of 20 parts of SPD (Figure 6.12). It is apparent that (NR/RR)/PP causes a lower reduction in elastic complex modulus and increment in mechanical damping ( $\tan \delta, 20^{\circ}\text{C}$ ) than that of other SPD's studied. The increase in impact strength produced by (NR/RR)/PP is lower than that of EPDM and NR/PP (Figure 6.12). This could be due to some factors which are discussed below.

The presence of reclaim rubber which contains vulcanised rubber and filler as mentioned above could increase the viscoelasticity of the rubber phase. The increased viscoelasticity will lead to a reduction in the relaxation mechanism of the rubber i.e., chain rotation which contributes to dissipating the externally applied energy during

impact. Therefore, blends containing such rubber become brittle and rigid, and as a result, the impact strength will be low. This is also reflected in the mechanical damping ( $\tan \delta$ ), where blends containing (NR/RR)/PP have a lower mechanical damping compared to that observed in blends containing EPDM and NR/PP. It was discussed that filler (e.g., carbon black) often decreases the damping of polymer<sup>(135,181)</sup> and lowers the impact strength<sup>(182)</sup>.

Moreover, blends containing (NR/RR)/PP are more incompatible than the corresponding blends containing EPDM and (NR/PP) due to the fact that (NR/RR)/PP has a complex composition i.e., filler, rubbers, other materials which are usually added into tyre compounds. Incompatible and heterogeneous polymer blends may fail easily during impact because the interfacial adhesion between rubber and matrix is very poor, which is important if good impact strength is to be achieved<sup>(183)</sup>. In the case of EPDM (see Chapter 5, Figure 5.3) it is expected that EPDM is compatible with PP and PE phases in the polyblend which provides a strong adhesion between rubber particles and matrix, hence the impact strength is higher.

### 6.2.3. Photo-oxidative Stability of PP/PE/SPD Ternary Blends Containing Reclaim Rubber

The deterioration of physical properties of the blends was followed by change in dynamic mechanical properties and

impact strength as a function of exposure time to UV-light (Figures 6.13-6.15). It is clear that the extent of decrease in mechanical damping ( $\tan \delta$ ) becomes higher with increasing concentration of SPD (Figure 6.13), on the other hand, elastic complex modulus increases (Figure 6.14). This must be due to photo-oxidative degradation in the rubber phase as observed in the previous Chapter (see Chapter 5, Section 5.2.2). Impact strength decreases with increasing concentration of SPD and exposure time (Figure 6.15).

Figures 6.16 to 6.18 show that properties of PP/PE blends containing 20 parts of (NR/RR)/PP, are less affected by photo-oxidative degradation after 100 hours light exposure than the corresponding blends containing EPDM and NR/PP. This implies that blends containing (NR/RR)/PP are quite stable to photo-oxidation. The reason for this photo-oxidative stability must be due to the presence of carbon black in the reclaim rubber phase which acts as a good screen.<sup>(180,182,184 )</sup>

Based on these results, it is clear that addition of reclaim rubber into NR/PP composition which is used as an SPD for PP/PE blends markedly improves the photo-oxidative stability of such blends in spite of the level of unsaturation in the natural rubber phase being quite high. This advantage may be useful for outdoor applications which require no high strength since the physical properties and impact strength of such blends are lower than that offered by EPDM and NR/PP composition.

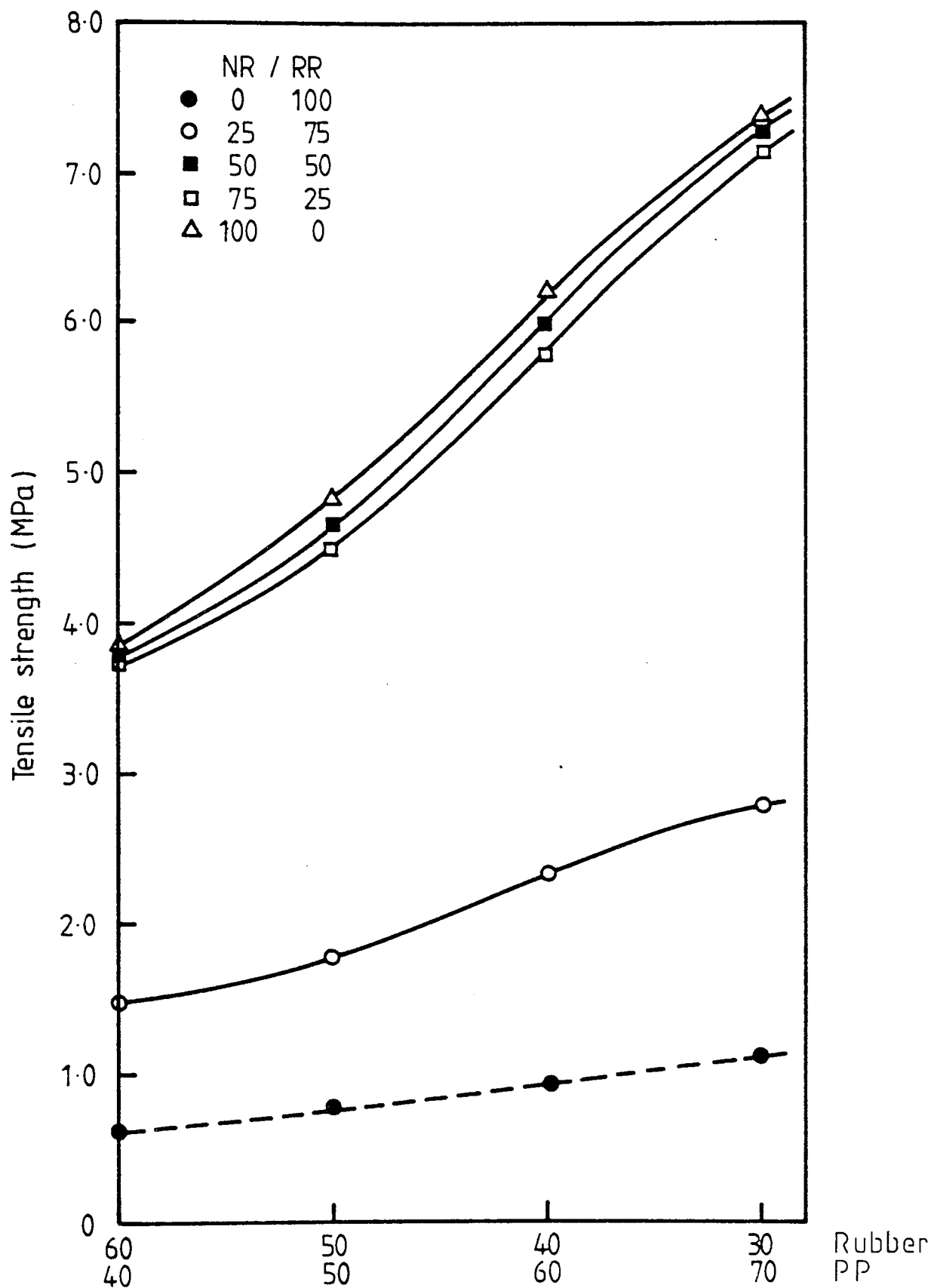

Figure 6.1 - The effect of variations of reclaim rubber to fresh rubber and rubber to polypropylene on the tensile strength of NR/PP blends, processed at 160°C for 10 minutes.

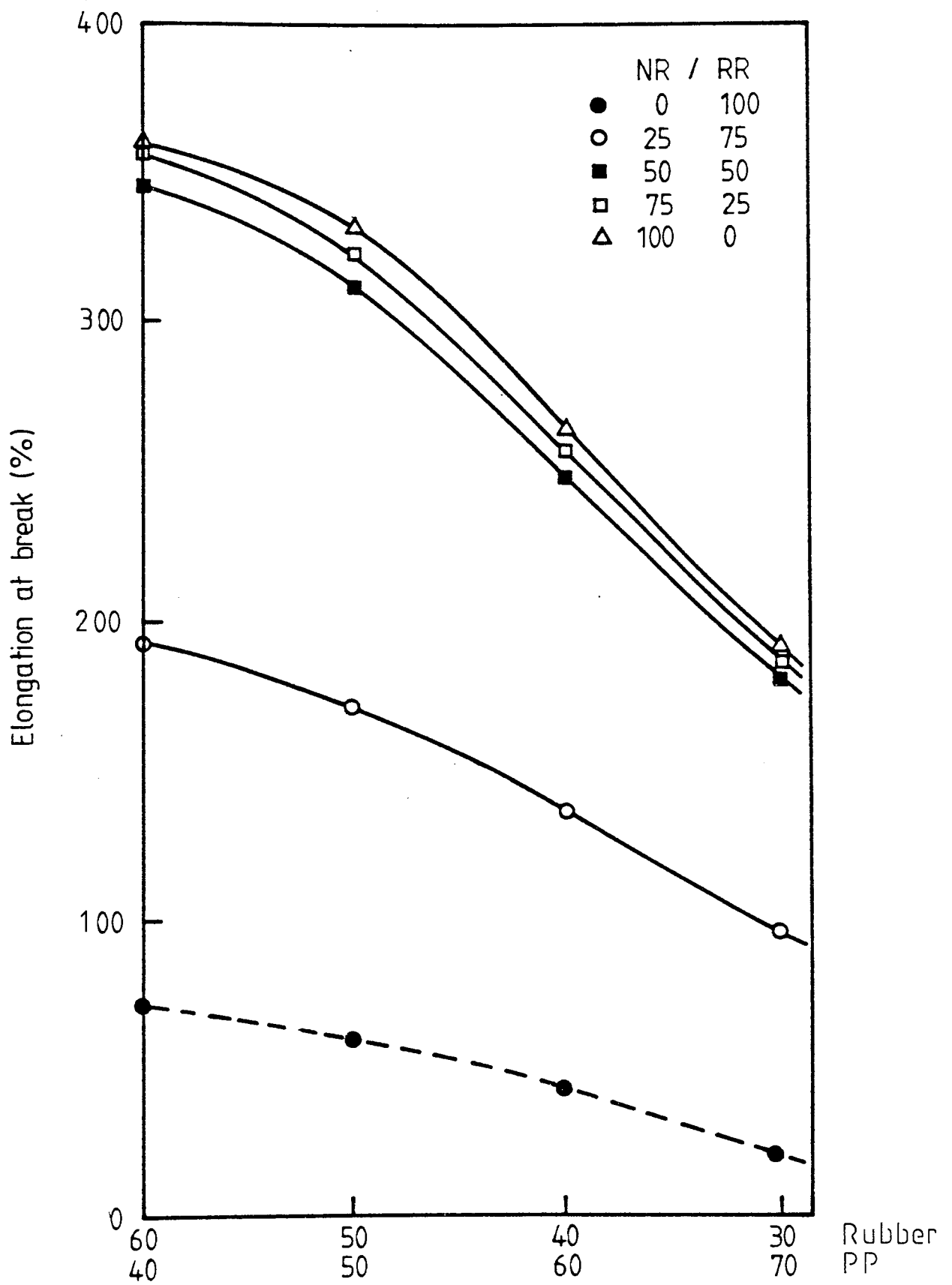

Figure 6.2 - The effect of varying proportion of NR to RR and polypropylene on the elongation at break of the blends.

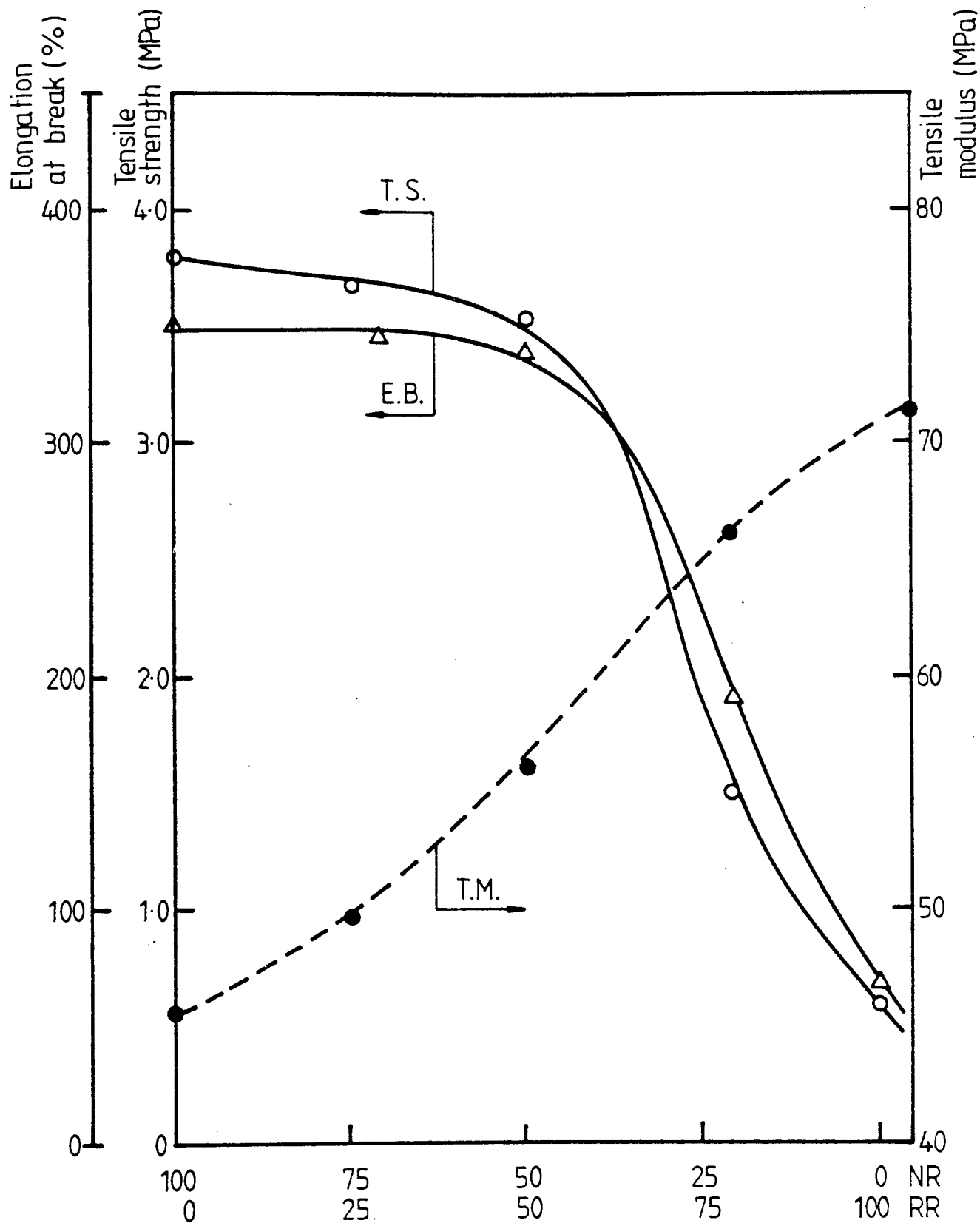

Figure 6.3 - The effect of reclaim rubber on the properties of NR/PP (60/40) blends, processed at 160°C for 10 minutes.

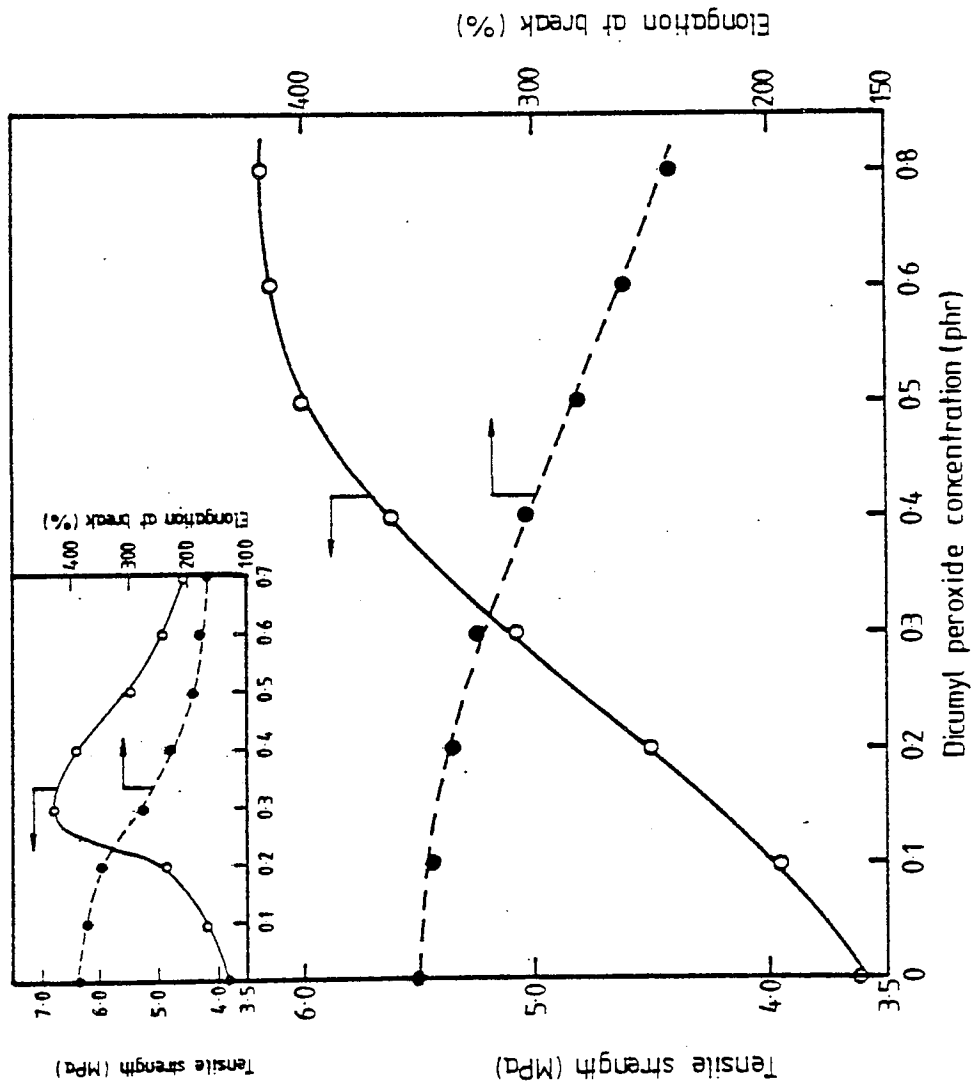

Figure 6.4 - Effect of dicumyl peroxide on the tensile properties of NR/PP(60/40) blends containing 50/50 NR/RR, processed in the Brabender Torque rheometer at 160°C for 10 minutes. (Inset shows the same effect on NR/PP (60/40) blends containing no reclaim rubber, processed under the same conditions).



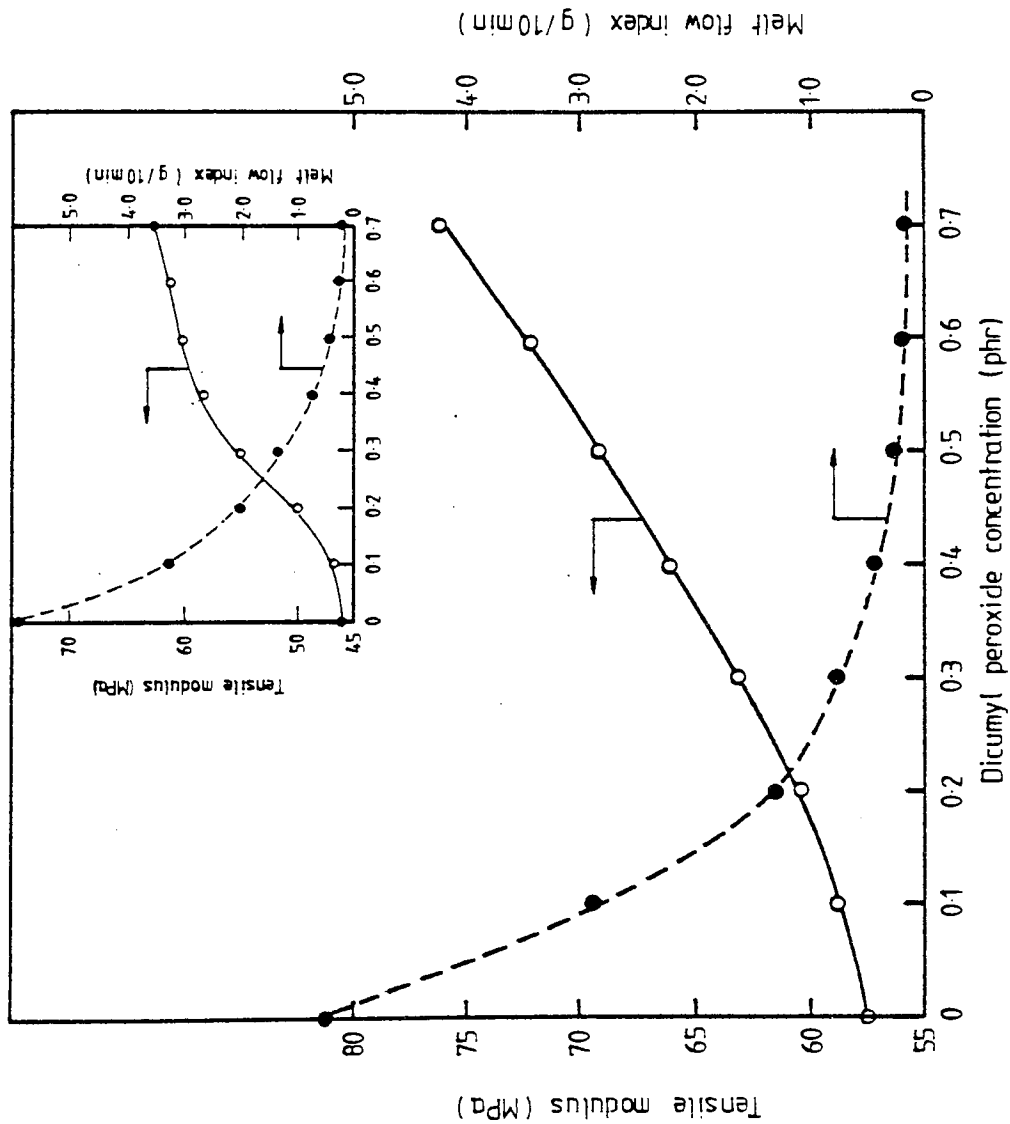

Figure 6.5 - The effect of dicumyl peroxide on the tensile modulus and melt flow index of NR/PP(60/40) blends containing 50/50 NR/RR processed in the Brabender Torque rheometer at 160°C for 10 minutes. (Inset shows the same effect on NR/PP(60/40) blends containing no reclaim rubber, processed under the same conditions).

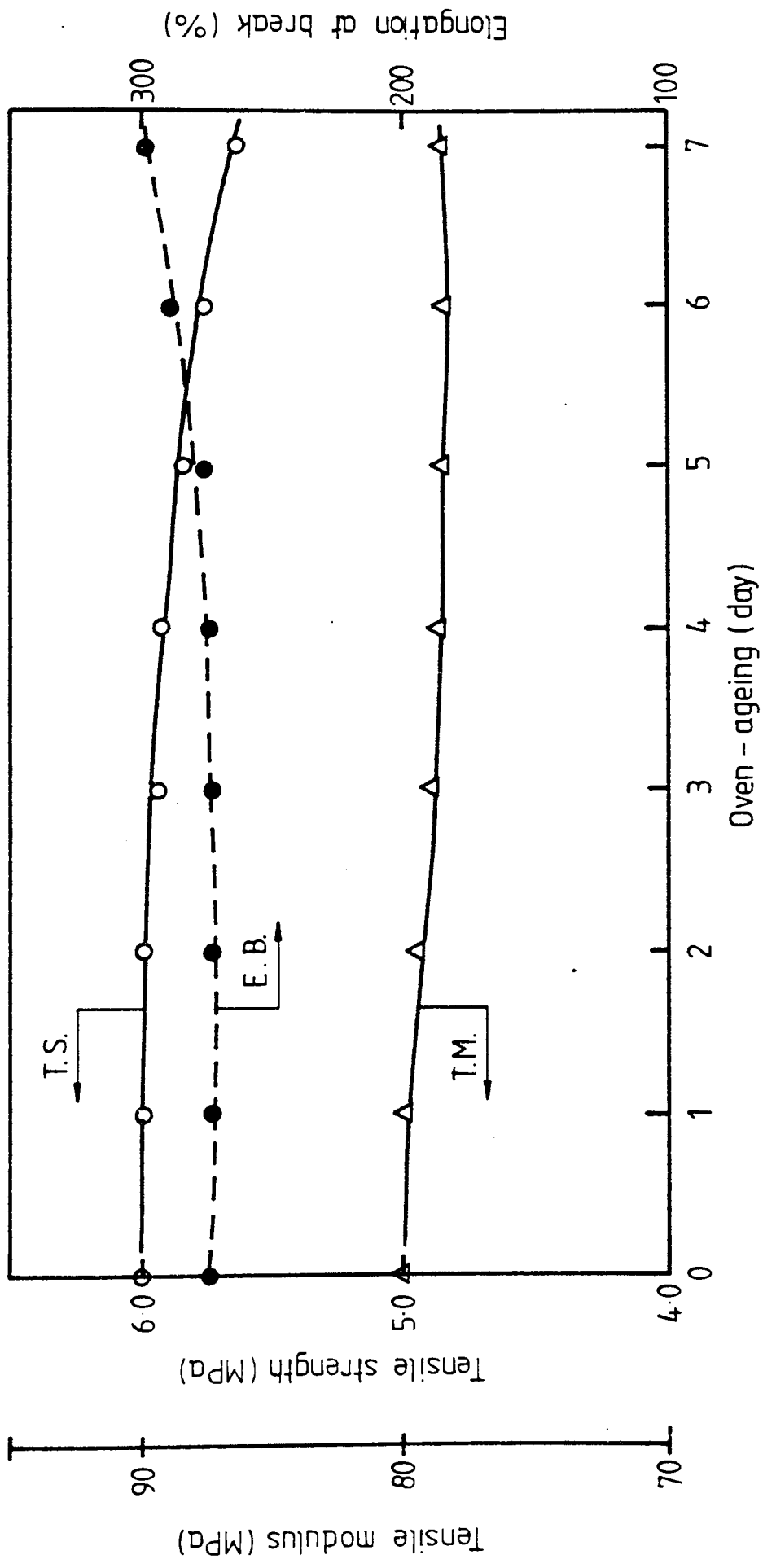

Figure 6.6 - The effect of oven-aging at 50 C on the tensile properties of (NR/RR)/PP (60/40) blends containing 0.5 phr. Dicumyl peroxide, processed at 160°C for 10 minutes.

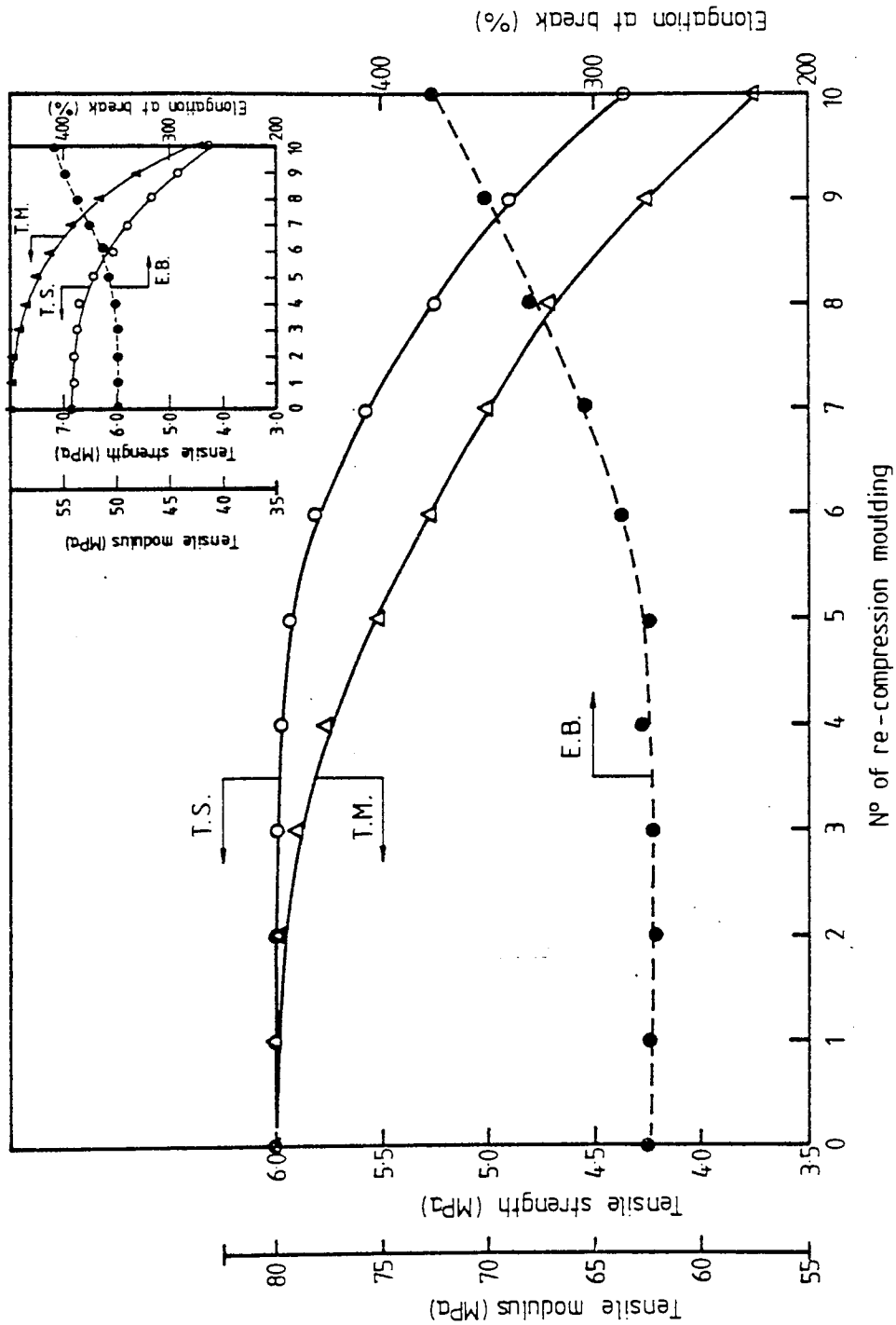

Figure 6.7 - The effect of recompression moulding on the tensile properties of (NR/RR)/PP(60/40) blends (NR:RR=50:50) containing 0.5 phr dicumyl peroxide processed in the Brabender Torque rheometer at 160°C for 10 minutes. (Inset shows the same effect on NR/PP blends (60/40) containing no reclaim rubber, 0.3 phr dicumyl peroxide, same processing procedure).

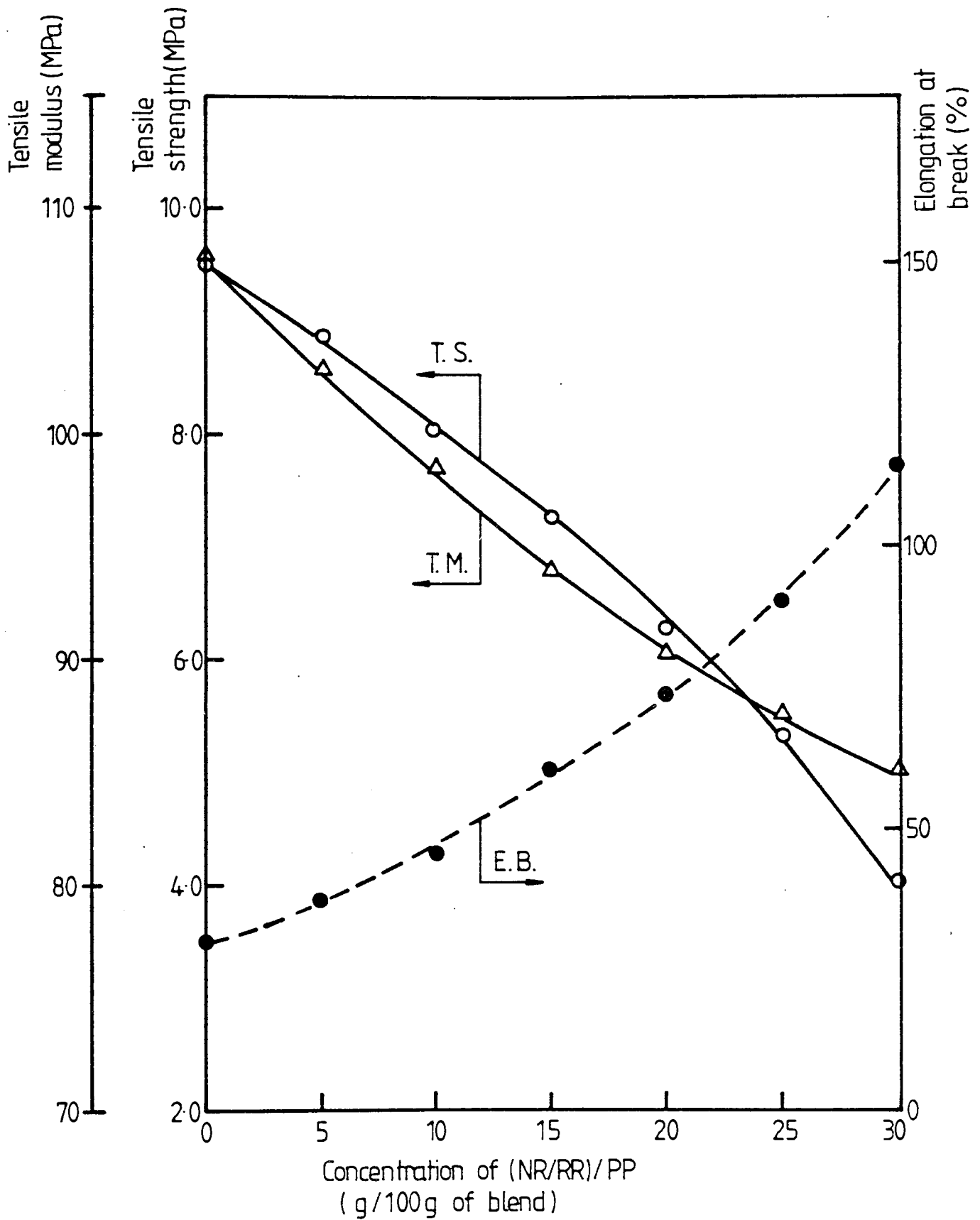

Figure 6.8 - Effect of (NR/RR)/PP as SPD on the tensile properties of PP/PE (1:1), processed at 180°C for 5 minutes.

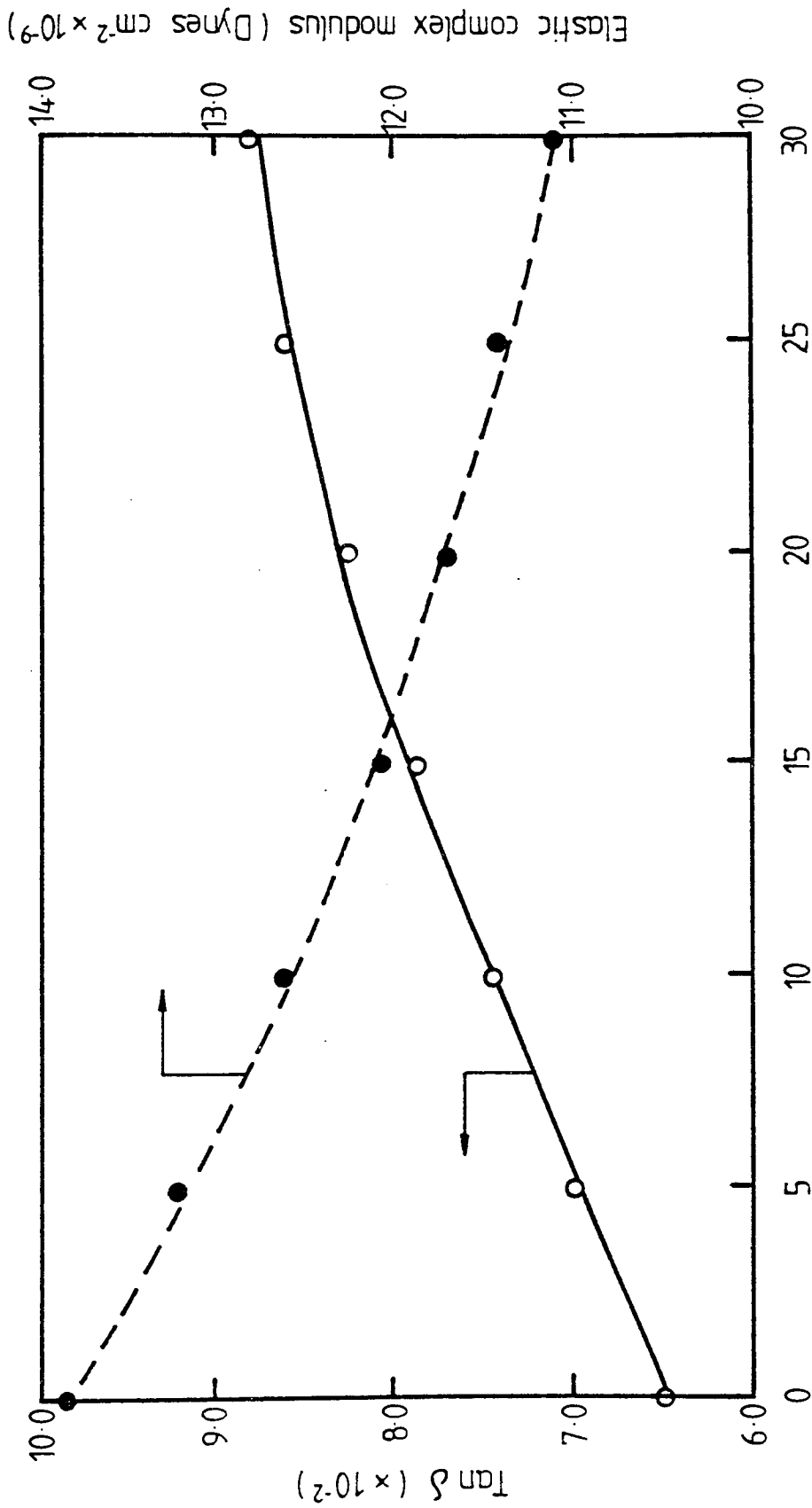

Figure 6.9 - Effect of (NR/RR)/PP as SPD on the dynamic mechanical properties of PP/PE (1:1) blends, processed at 180°C for 10 minutes.

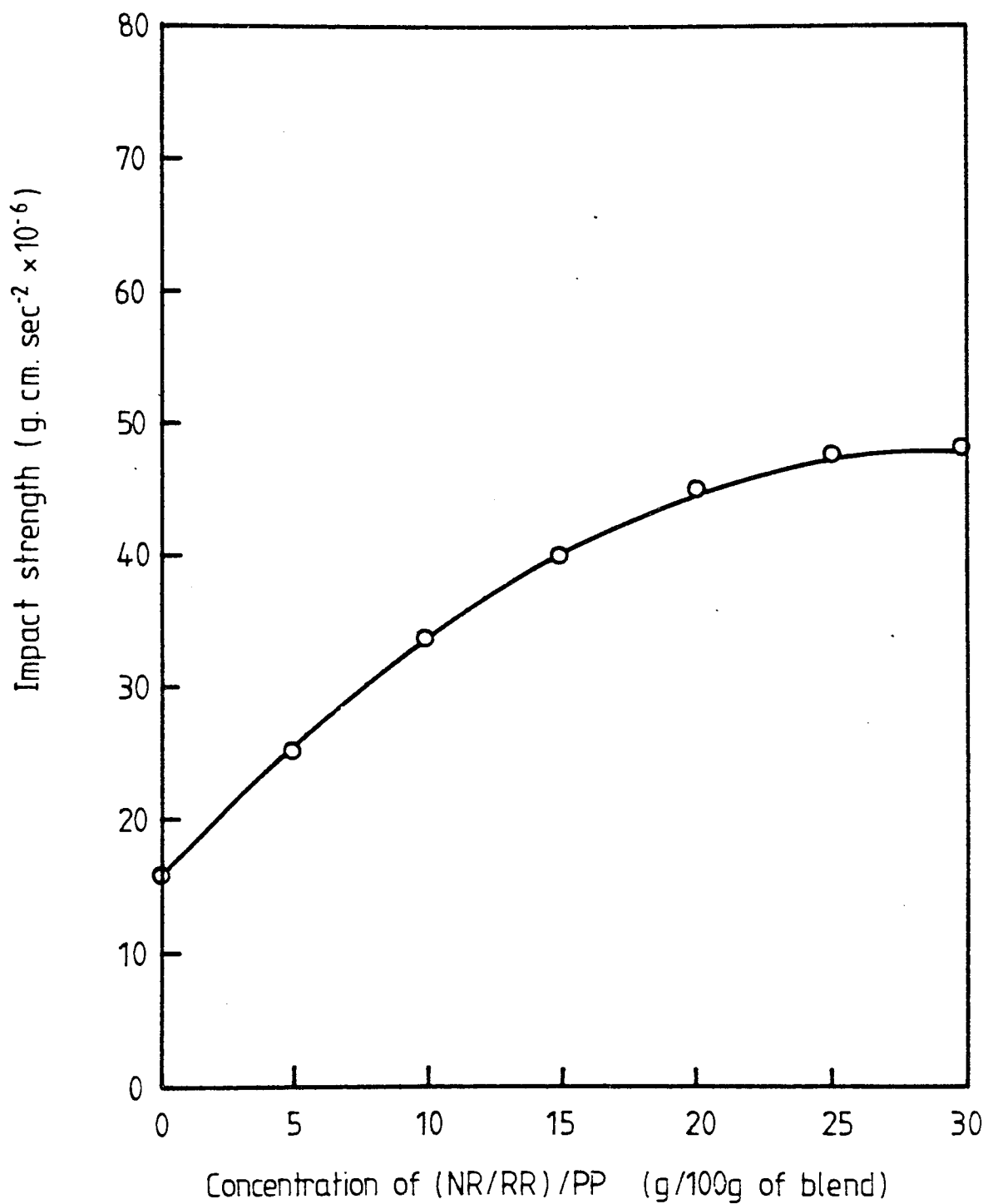

Figure 6.10 - Effect of (NR/RR)/PP as SPD on the impact strength of PP/PE (1:1) blend processed at 180°C for 5 minutes.

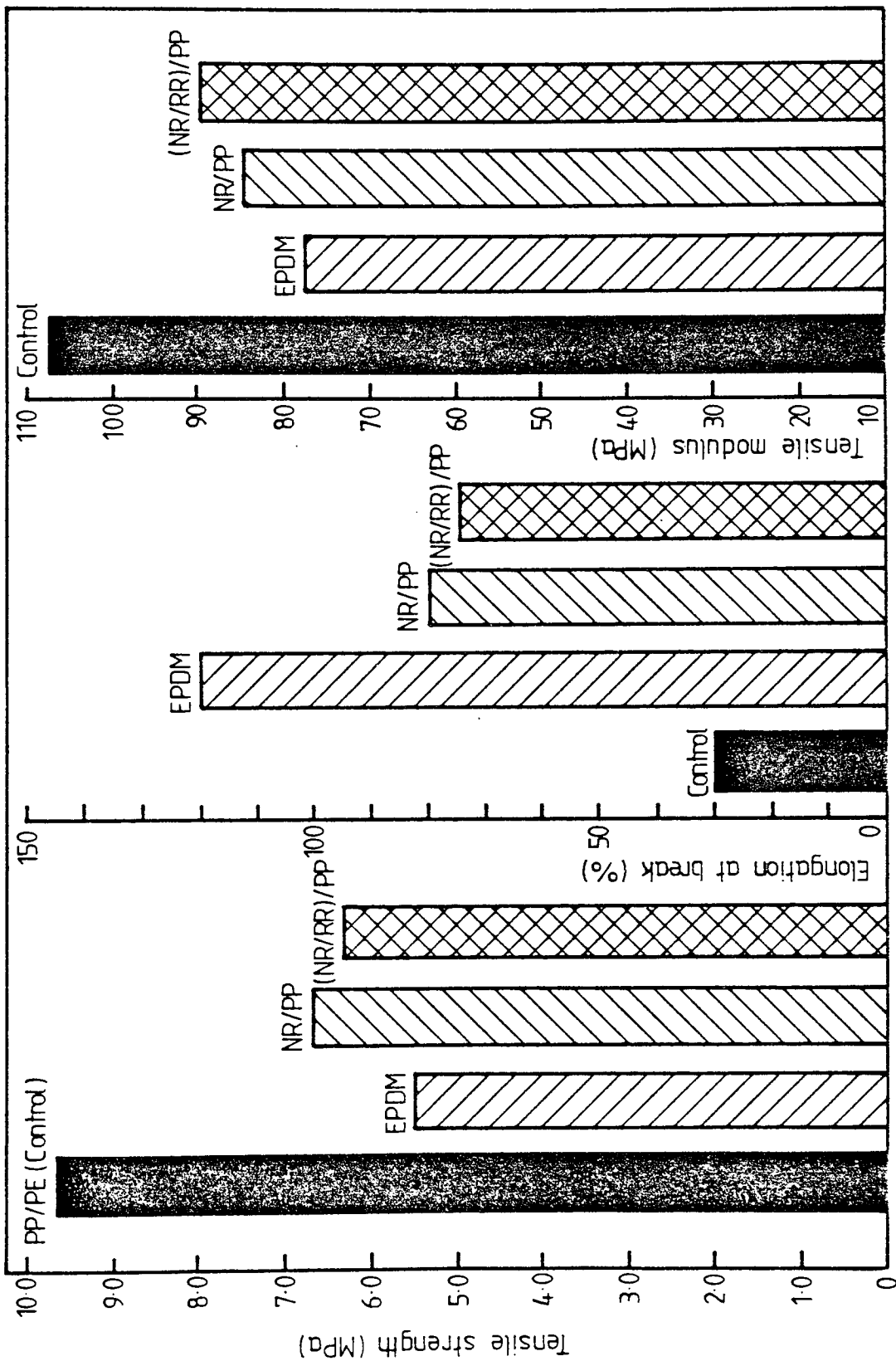

Figure 6.11 - Comparison of tensile properties of PP/PE (50:50) and PP/PE/SPD (40:40:20) blends (containing different SPDs), processed in a Brabender Torquerheometer at 180°C for 5 minutes.

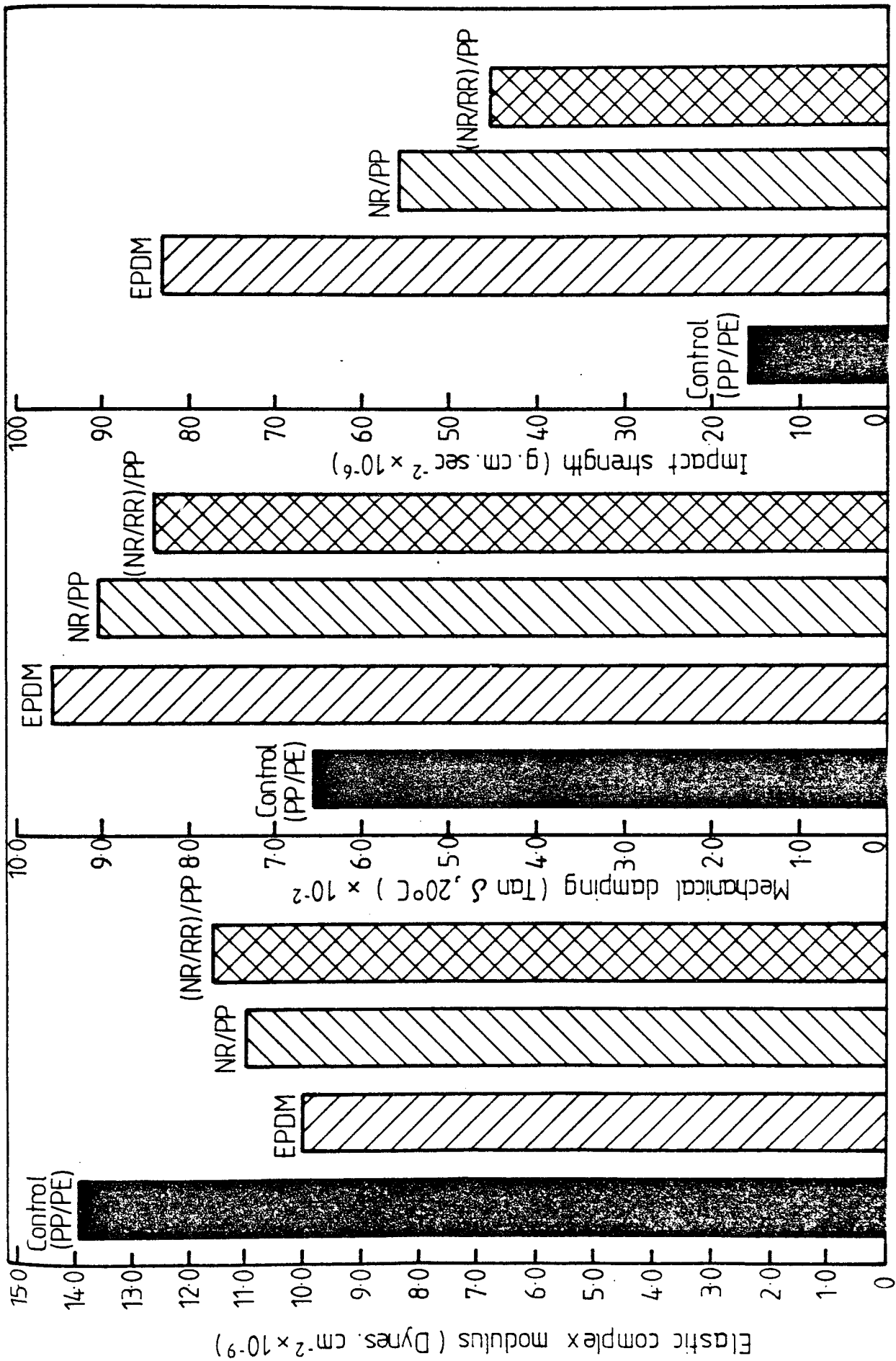

Figure 6.12 - Comparison in the dynamic mechanical properties and impact strength of PP/PE (50:50) and PP/PE/SPD (40:40:20) blends (containing different SPDs), processed at Brabender Torque rheometer at 180°C for 5 minutes.



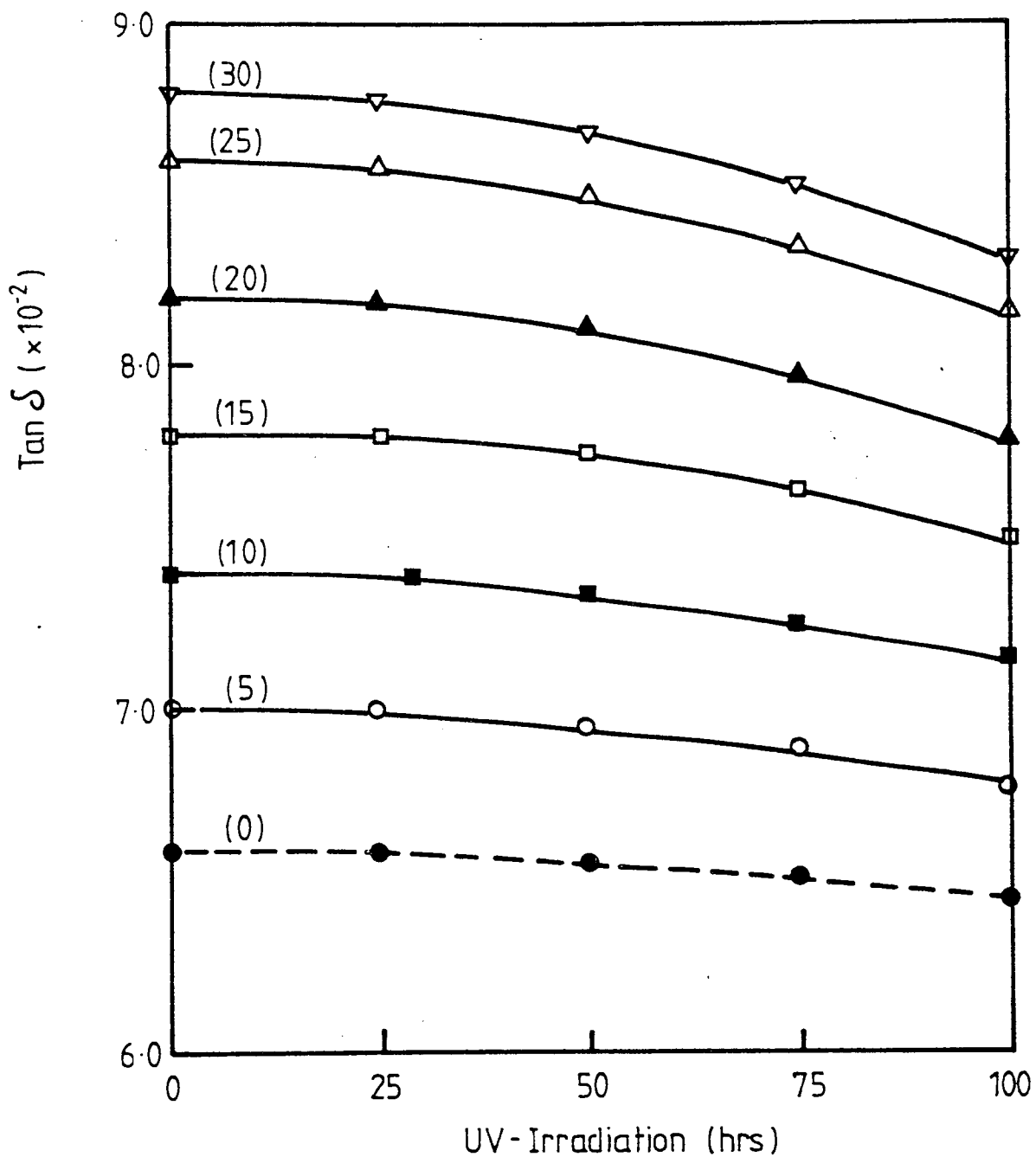

Figure 6.13 - Effect of (NR/RR)/PP on the mechanical damping ( $\text{Tan } \delta$ , at  $20^{\circ}\text{C}$ ) of PP/PE (1:1) blends (numbers in parenthesis designate the concentration of (NR/RR)/PP) as SPD

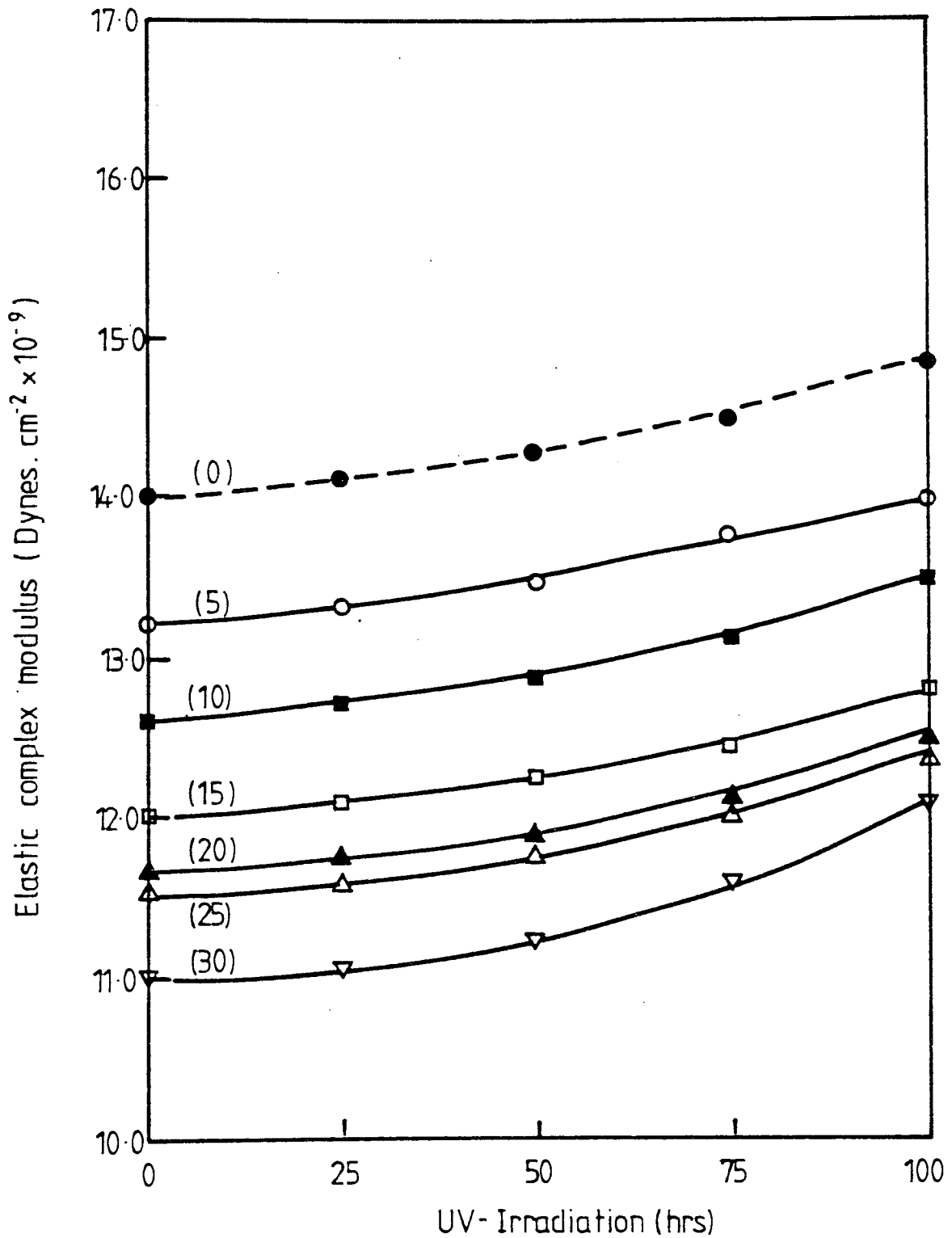

Figure 6.14 - Effect of (NR/RR)/PP concentration on the elastic complex modulus of PP/PE (1:1) blends during UV-irradiation (number in parenthesis designates the concentration of (NR/RR)/PP as SPD)

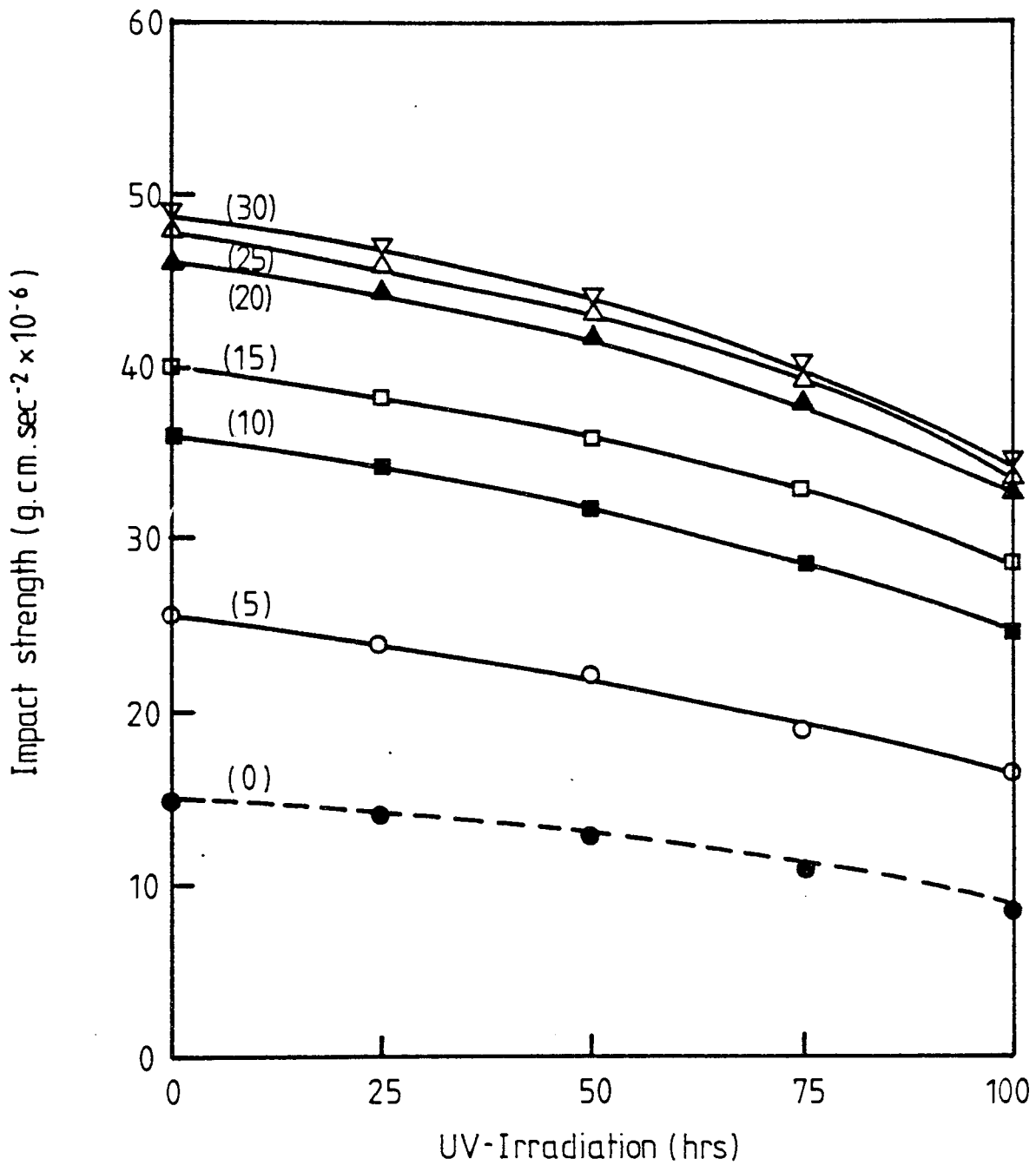

Figure 6.15 - Effect of (NR/RR)/PP concentration on the impact strength of PP/PE (1:1) blends during UV-Irradiation (number in parenthesis designates the concentration of (NR/RR)/PP as SPD).

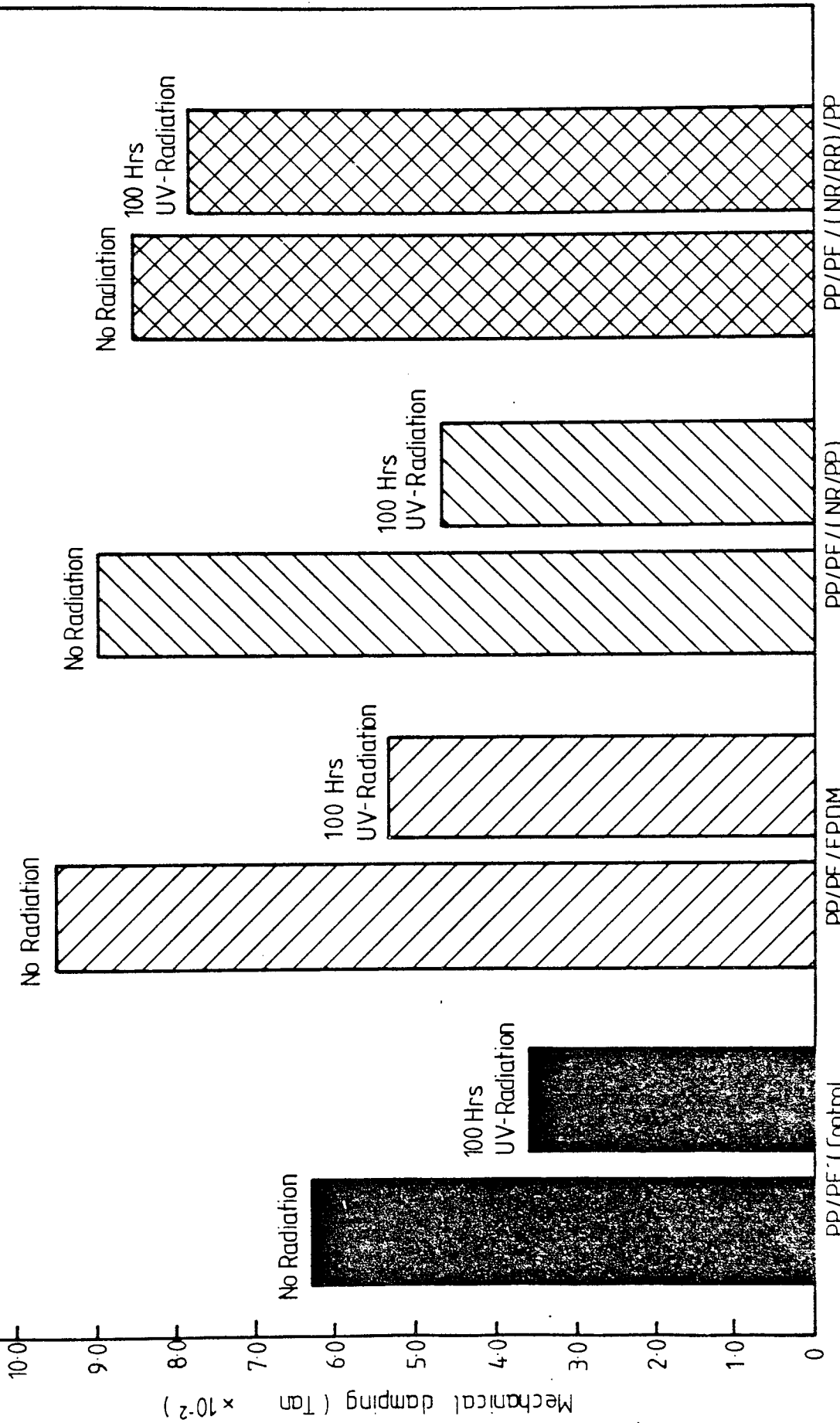

Figure 6.16 - Comparison in the effect of UV-Radiation on the mechanical damping of PP/PE containing different SPDs (ratio PP/PE/SPD : 40/40/20) processed in the Brabender Torqueheometer at 180°C for 5 minutes



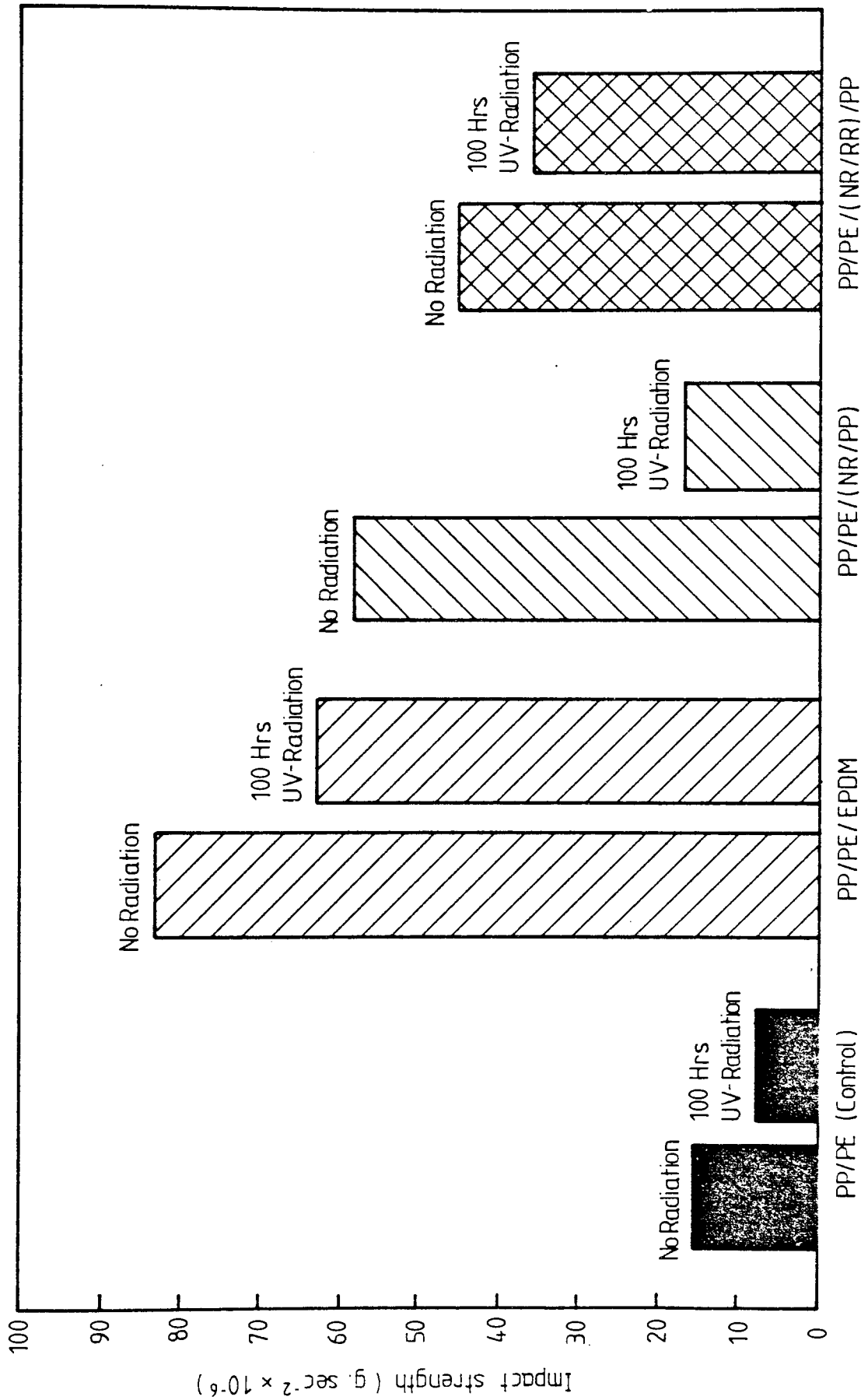

Figure 6.18 - Comparison in the effect of UV-Radiation on the impact strength of PP/PE/SPD containing different SPDs (ratio PP/PE/SPD : 40/40/20) processed in the Brabender Torqueheometer at 180°C for 5 minutes.

CHAPTER SEVEN

CONCLUSIONS AND SUGGESTIONS FOR  
FURTHER WORK

## 7.1 Conclusions

- 7.1.1 The tensile properties of natural rubber-polypropylene blends is mostly dependent on the ratio of rubber to polypropylene. At low polypropylene ratio (e.g., 70/30), the blends behave as uncrosslinked rubbers i.e., high elongation at break and low tensile strength, while at higher polypropylene ratio (e.g., 40/60) a typical thermoplastic blend was obtained (high tensile strength and low elongation at break). Ratio of rubber to polypropylene of 60/40 was found to offer a thermoplastic rubber behaviour.
- 7.1.2 The effect of processing time and temperature on the tensile properties of natural rubber-polypropylene blends containing no free radical initiator was inconclusive. Effect of these variables on the amount of bound natural rubber was only marginal.
- 7.1.3 Benzoyl peroxide was not found to be an effective free radical initiator. Dicumyl peroxide was much more effective, and contributed to a significant increase in tensile strength of natural rubber-polypropylene blend. It was also observed that bound natural rubber increased with increasing concentration of dicumyl peroxide. Correlation of bound natural rubber and tensile properties was found to be ambiguous. Viscosity of the blends increased with increasing concentration of dicumyl peroxide.



7.1.4 There was no evidence of any interpolymerisation reaction between natural rubber and polypropylene. It was found that natural rubber and polypropylene were likely to form a physical blend rather than a chemically bounded blend. Free radical initiator was unlikely to promote interpolymer reaction, but partly crosslinked the rubber phase and caused degradation reactions on the polypropylene phase.

This convincing evidence was also proved from the study of glass transition temperature and molecular weight determination.

7.1.5 Degradation process which occurs in the polypropylene phase becomes an important factor in determining the physical properties of the blends. This was shown when high processing temperatures and high shear rate were used and did reflect inferior tensile properties.

7.1.6 Ethylene-propylene terpolymer (EPDM) was also found not to improve the adhesion between natural rubber and polypropylene phases in the blend. Tensile properties and glass transition temperature were found not to be affected by the addition of EPDM.

7.1.7 Carbon black was found to have a marginal effect on the tensile properties of natural rubber-

polypropylene blends. A significant effect of the addition of carbon black was found on the viscosity of the blends which increased with increasing concentration of carbon black. This may be due to the effect of perturbation of flow, not because of the interaction between carbon black and the phases of the blend.

7.1.8 The oxidative-stability study indicated that NR/PP blends were not resistant to photo-oxidation and high temperatures. This may be due to the high unsaturation level and hence formed hydroperoxide concentration. On the other hand, these blends were quite stable under oven-ageing test at 50°C. Re-compression and re-injection moulding studies indicates that one is able to recycle these blends, therefore, scraps and rejects can be reprocessed.

7.1.9 Natural rubber-polypropylene were found to be capable of improving toughness of polyethylene-polypropylene blends, even though they were less effective compared with EPDM. From the photo-oxidation study, it was found that the natural rubber phase is responsible for the lower photo-oxidative stability of polyblends.

7.1.10 The stabilisation studies showed that stabiliser systems based on the combination of UV-absorber/screen , peroxide decomposer and chain breaking

anti-oxidant are the most effective.

The least effective ones were stabiliser systems which are based on hindered phenols and Ni-complex. It seemed that they were antagonistic.

7.1.11 Reclaim rubber was found to be useful for the preparation of natural rubber-polypropylene blends. It was found that properties of natural rubber-polypropylene (60/40) blend could be maintained by replacing up to half of fresh rubber by reclaim rubber. The use of (NR/RR)/PP in the modification of PP/PE blends showed an improvement in the toughness of PP/PE blends. Photo-oxidative stability of PP/PE blends containing (NR/RR)/PP was higher than the corresponding blends containing NR/PP.

## 7.2 Suggestions for Further Work

7.2.1 A morphology study on the natural rubber-polypropylene blend could be very useful to investigate the interaction between the two phases. Transmission Electron Microscopy could provide a clear picture of dispersion and adhesion of the two phases in the blend.

7.2.2 Dicumyl peroxide was found to be an effective free radical initiator which improved the tensile

properties of natural rubber-polypropylene blends. Other peroxides could provide a better effect on the properties of blend, therefore, a wide range of peroxide should be investigated.

- 7.2.3 An improvement of compatibility of natural rubber and polypropylene should be thoroughly studied. A compatible blend of natural rubber and polypropylene is highly preferred to improve the dispersion of two phases leading to better overall properties.
- 7.2.4 Incorporation of different stabiliser systems should also be studied in order to improve the stability of NR/PP blends during processing and service. Furthermore, for applications which require high photo-oxidative and thermal-oxidative stabilities, the incorporation of some stabiliser will be necessary.
- 7.2.5 The use of natural rubber-polypropylene blends for modification of binary thermoplastic blends should be applied for a wide range of blends in order to increase the technological usefulness of this blend.
- 7.2.6 A study on mechanism of stabilisation on NR/PP blends must be investigated in order to find stabiliser systems which could give an adequate protection against environment degradation. This will

be very useful for NR/PP which will be used as impact modifier on PP/PE blends. Bound anti-oxidant on the rubber phase may be very interesting for further study on the stabilisation of NR/PP blends.

- 7.2.7 To obtain the highest quality of (NR/RR)/PP, further research in more detail still needs to be carried out, since reclaim rubber is a cheap material.

## APPENDICES

APPENDIX I

Chemicals and Solvents used in the Experiment

---

Name	Supplier
1. Benzoyl Peroxide	BDH Chemicals
2. Dicumyl Peroxide	Hercules
3. Tetrahydrofuran (THF)	BDH Chemicals
4. Dekalin	BDH Chemicals
5. Nonox WSP	ICI Ltd.
6. Carbon Black (HAF 30)	Sevaco, Bristol
7. TBH (Ter-butyl Hydroperoxide)	Akzo Chemicals

---

APPENDIX 2

Stabilisers used in PP/PE/SPD (40:40:20) blends (Chapter 5, Section 5.2.3)

DLTP : Dilauryl-3 3-thiodipropionate

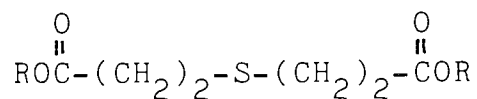

NiDBP

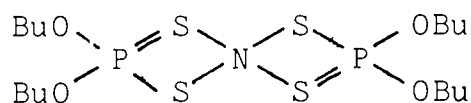

HOBP (UV 531)

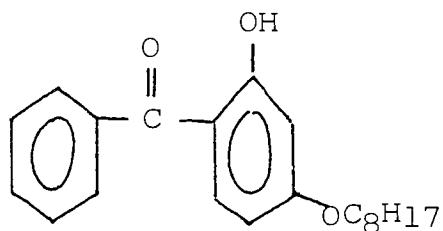

Cyasarb 1084

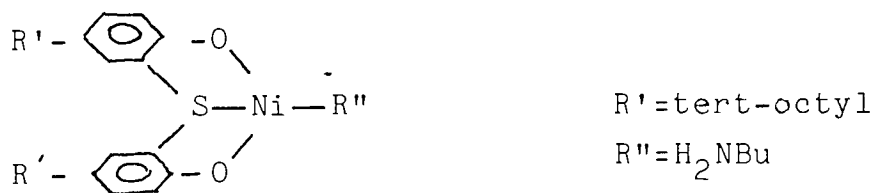

Tinuvin 770

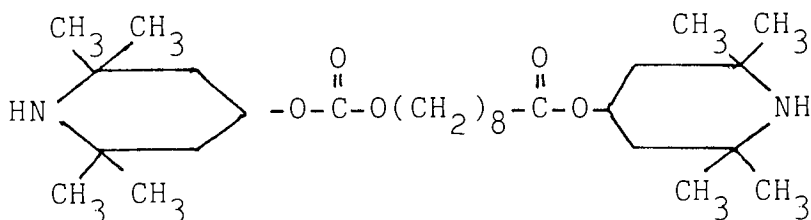



APPENDIX 2 continued

Irganox 1076

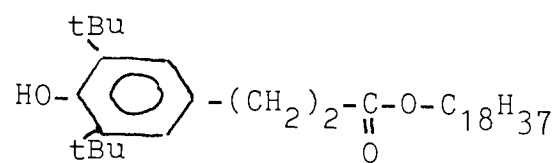

DBDS : di-n-Butyl Thiophosphoryl Disulphide

REFERENCES

- (1) E.N. Kresge, Rubbery Thermoplastic Blends in "Polymer Blends" (Ed. D.R. Paul and S. Newman) Vol 2, Academic Press, 1978, p.293.
- (2) D.J. Elliot, Developments with Natural Rubber in "Developments in Rubber Technology" (Ed. A. Whelan and K.S. Lee) Applied Science Publishers, 1979, 33.
- (3) D.J. Elliot, N.R. Technol. 12(3), 59, 1978.
- (4) H.R. Katz and B.M. Walker, "Handbook of Thermoplastic Elastomers" (Ed. B.M. Walker) Van Nostrand Reinhold Co. 1979, p.1.
- (5) L. Mullins, Rubb. Dev., 31(4), 92, 1978.
- (6) P.A. De Paolo, Rubb. World, 182, 43, 1980.
- (7) A.L. Bull, Plast. and Rubb. Intern., 6(6), 240, 1981.
- (8) D.S. Campbell, D.J. Elliot and M.A. Wheelans, N.R. Technol., 9(21), 21, 1978.
- (9) A.Y. Coran and R.P. Patel, Rubb. Chem. Technol., 53(1), 141, 1980.
- (10) M. Pineri and C. Meyer, J. Polym. Sci. Polym. Phys. Ed., 12, 115, 1974.
- (11) R.W. Seymore, A.E. Allegraza Jn and S.L. Cooper, Macromol., 6(6), 896, 1973.
- (12) R.J. Cella, J. Polym. Sci. Symp., No42, 727, 1973.
- (13) M. Kojima and J.H. Magill, J. App. Phys., 15(10), 4159, 1974.
- (14) A. Noshay and A. Metzner, Am. Chem. Soc. Polym. Prep., 13(1), 292, 1972.
- (15) J.C. Saam, A.H. Ward and F.W. Fearon, Am. Chem. Soc. Polym. Prep., 13(1), 525, 1972.
- (16) J.V. Dawkins, "Block Copolymers" (Eds. D.C. Allport and W.H. Janes), Applied Science Publishers, 1973, p.402.

- (17) J.A.Brydson, Thermoplastic Rubbers in "Rubber Chemistry" Applied Science Publisher, 1978, p.432.
- (18) P.Dreyfuss, L.J.Fetters and D.R.Hanson, Rubb.Chem.Technol., 53(3), 728, 1980.
- (19) H.L.Morris, Polyolefin Thermoplastic Elastomers (Ed. B.M.Walker), Van Nostrand Reinhold Co., 1979, p.5.
- (20) J.A.Brydson, Thermoplastic Rubbers - An Introductory Review in "Developments in Rubber Technology" (Ed. A.Whelan and K.S.Lee) Vol 3, Applied Science Publishers, 1982, p.1.
- (21) Ref. 17, p.341.
- (22) G.Holden, E.T.Bishop and N.R.Legge, Proc.Intern.Rubb. Conf. Brighton, 1967, p.290.
- (23) Ref. 1, p.314.
- (24) J.A.Brydson, Aliphatic Olefin Rubbers in "Plastic Materials" Butterworths, 1982, p.275.
- (25) S.C.Wells, J.Elastoplas., 5, 102, 1973.
- (26) C.S.Schollenberger, H.Scott and G.R.Moore, Rubb.World, 137, 549, 1958.
- (27) D.J.Haropp, Thermoplastic Polyurethanes in "Developments in Rubber Technology" (Eds. A.Whelan and K.S.Lee) Vol.3, Applied Science Publishers, 1982, p.147.
- (28) S.Wolkenbreit, Thermoplastic Polyurethane Elastomers in "Handbook of Thermoplastic Elastomers" (Ed. B.M.Walker), Van Nostrand Reinhold, 1979, p.217.
- (29) P.W.Wright and A.P.C.Cummings, "Solid Polyurethane Elastomers" Mc.Laren and Sons, 1979.
- (30) C.S.Schollenberger, K.Dinbergs and F.D.Stewart, Rubb. Chem. Technol., 55, 138, 1982.

- (31) N.R.Liege, G.Holden, S.Davidson and H.E.De La Mare,  
"Applied Polymer Science, Organic Coating and Plastic  
Chemistry", Am.Chem.Soc.Washington, 1975, p.394.
- (32) A.D.Thorn, "Thermoplastic Elastomers", RAPRA, Shrewsbury,  
1980, p.136.
- (33) J.Blackwell and K.H.Gardner, Polym., 20, 13, 1979.
- (34) R.Bonart, J.Macromol.Sci.-Phys.Part B2(1), 115, 1968.
- (35) R.Bonart, L.Morbitzer, and G.Hentze, J.Macromol.Sci.-  
Phys., Part B3(1), 337, 1969.
- (36) S.Clough and N.Schneider, J.Macromol.Sci.-Phys., Part  
B2(4), 553, 1968.
- (37) J.A.Koutsky, N.V.Hien and S.L.Cooper, J.Polym.Sci.,  
Part B8, 353, 1970.
- (38) I.Kimura, Macromol.Prepr., 1, 525, 1971.
- (39) D.Huh and S.Cooper, Polym.Eng.Sci., 11(5), 369, 1971.
- (40) J.Ilinger, Polym.Eng.Sci., 12(1), 25, 1972.
- (41) B.D.Simpson, "The Vanderbilt Rubber Handbook"(Ed.  
R.O.Babbit), R.T.Vanderbilt Co., 1978, 233.
- (42) R.J.Angelo, R.M.Ikeda and M.L.Wallach, Polym., 6, 141, 1965.
- (43) G.Kraus, C.W.Childers and J.T.Gruver, J.App.Polym.Sci.,  
11, 1581, 1967.
- (44) J.R.Haws and R.F.Wright, Block Polymers in "Handbook of  
Thermoplastic Elastomers"(Ed.B.M.Walker), Van Nostrand  
Reinhold Co., 1972, p.72.
- (45) D.J.St Clair, Rubb.Chem.Technol., 55, 209, 1982.
- (46) G.Holden, E.T.Bishop and N.Legge, J.Polym.Sci., C26, 37,  
1969.

- (47) R.F.Zelinski, U.S. Patent, 3,281,383, (1966).
- (48) E.M.Fodor "New Industrial Polymers" (Ed. R.D.Deanin) ACS Symposium Series 4, ACS Washington 1974, p.37.
- (49) M.M.Wald and M.G.Quamm, U.S. Patent, 3,595,942, (1971)
- (50) W.H.Janes "Block Copolymers" (Eds. D.C.Allport and W.H. Janes), Applied Science Publishers Ltd., 1973, p.62
- (51) L.Mistrali and A.Pironi, Styrenic Block Copolymers in "Developments in Rubber Technology" (Eds. A Whelan and K.S.Lee), Vol.3, Applied Science Publishers, 1982, p.64.
- (52) G.Holden, "Block and Graft Copolymerisation" (Ed. R.J. Ceresa), Vol.1, John Wiley and Sons, 1973, p.146.
- (53) G.J.Holden, J.Elastoplast., 2, 234, 1970.
- (54) S.Futamura and E.A.Meinecke, Polym.Eng.Sci., 17, 563, 1977.
- (55) Ref.20, p.6.
- (56) R.J.Cella, J.Polym.Sci., C42(2), 727, 1973.
- (57) G.L.Zaiser, Plast.Eng., 34(5), 61, 1978.
- (58) S.C.Wells, Polyester Thermoplastic in "Handbook of Thermoplastic Elastomers" (Ed. B.M.Walker), Van Nostrand Reinhold Co., 1978, p.103.
- (59) Du Pont Innovation, 4(1), 13, 1972.
- (60) M.Brown and W.K.Witsiepe, Rubber Age, 104(3), 35, 1972.
- (61) J.R.Wolfe, Rubb.Chem.Technol., 50, 658, 1977.
- (62) J.R.Wolfe, Adv.Chem.Ser., 176, 129, 1979.
- (63) W.K.Witsiepe, "Polymerisation Reactions and New Polymers" (Ed. N.A.J.Platzer), Advances in Chemistry Series, 129, 39, 1973.
- (64) W.H.Buck and R.J.Cella, A.C.S. Polym.Prepr., 14, 98, 1978.
- (65) I.R.Lloyd, Polyester Elastomers in "Developments in Rubber Technology" (Eds. A.Wheelan and K.S.Lee), Vol.3, Applied Science Publishers, 1982, p.187.

- (66) A.Lilaonitkul and S.L.Cooper, *Rubb.Chem.Technol.*, 50, 1, 1977.
- (67) H.L.Morris, Polyolefin Thermoplastic Elastomers in "Handbook of Thermoplastic Elastomers" (Ed.B.M.Walker), Van Nostrand Reinhold Co., 1978, p.5.
- (68) H.L.Morris, *J.Elastoplast.*, 6, 1, 1974.
- (69) W.K.Fisher, (to Uniroyal) U.S.Patent, 3,758,643 (1971).
- (70) W.K.Fisher, (to Uniroyal) U.S.Patent, 3,806,558 (1971).
- (71) A.Fritz, (to Du Pont) Germ.Offen., 2,429,889 (1975).
- (72) P.F.Hartman, U.S.Patent, 3,909,463 (1975).
- (73) Ref.32, p.2.
- (74) R.Ranali, Ethylene-Propylene Rubber-Polypropylene Blends in "Developments in Rubber Technology" (Eds.A.Whelan and K.S.Lee), Vol.3, Applied Science Publishers Ltd., 1982, p.42.
- (75) Ref.1, p.321
- (76) A.Y.Coran and R.P.Patel, *Rubb.Chem.Technol.*, 53(3), 781, 1980.
- (77) Ref.32, p.127.
- (78) A.Rudin, *J.Macromol.Sci.Rev.Macromol.Chem.*, C19(2), 267, 1980.
- (79) A.Y.Coran, R.P.Patel and D.Williams, *Rubb.Chem.Technol.*, 55(1), 116, 1981.
- (80) T.D.Pendle, "Block and Graft Copolymerisation, (Ed.R.J.Ceresa), Vol.1, John Wiley and Sons, 1973, p.83.
- (81) D.S.Campbell, Production, Properties and Performance of NR-Polystyrene Graft Copolymers, MRPRA Prepr., 1982.
- (82) M.Pike and W.F.Watson, *J.Polym.Sci.*, 9, 229, 1952.
- (83) W.F.Watson, *Trans.I.R.I.*, 34, 237, 1958.

- (84) R.J.Ceresa, Trans.I.R.I., 36, 45, 1960.
- (85) R J Ceresa, "Block and Graft Copolymerisation" (Ed. R.J.Ceresa), Vol.1, John Wiley and Sons, 1973, p.60.
- (86) D.J.Angier and W.F.Watson, J.Polym.Sci., 18, 129, 1955.
- (87) D.J.Angier and W.F.Watson, Trans.I.R.I., 33, 22, 1957.
- (88) D.J.Angier and W.F.Watson, J.Polym.Sci., 20, 235, 1956.
- (89) L.C.Bateman, Ind.Chem.Eng., 49, 704, 1957.
- (90) D.J.Angier, R.J.Ceresa and W.F.Watson, J.Polym.Sci., 34, 699, 1959.
- (91) R.G.R.Bacon, E.H.Farmer and P.Schidrowitz, Proc.Rubb. Techn.Conf.London, 1938, p.525.
- (92) P.Compagnon and J.Le Bras, J.Rubb.Chem.Techn., 20, 689, 1947.
- (93a) G.F.Bloomfield, Rubb.Develop., 5, 34, 1952.
- (93b) "Heveaplus" NRPR Techn.Bull.No 1, 1954
- (94) G.F.Bloomfield and P.Mc.L.Swift, J.App.Chem., 5, 609, 1955.
- (95) P.W.Allen and F.M.Merrett, J.Polym.Sci., 22, 193, 1956.
- (96) F.M.Merrett, J.Polym.Sci., 24, 24, 1957.
- (97) P.W.Allen, C.L.M.Bell and E.G.Cooockbain, Rubb.Chem. Techn., 33(3), 285, 1960.
- (98) P.W.Allen, G.Ayrey, C.G.Moore and J.Scanlan, J.Polym. Sci., 36, 55, 1959.
- (99) R.N.Mathurajah. Rubb.Res.Inst.Malaya , Planters' Bull., 74, 131, 1964.
- (100) B.C.Sekhar, Rubb.Chem.Techn., 31, 3430, 1958.
- (101) J.E.Morris and B.C.Sekhar, Proc.Intern.Rubb.Conf. Washington, 1959, p.277.



- (102) D.S.Campbell,D.E.Loeber and A.J.Tinker,Polymer,19,  
1106,1978.
- (103) D.S.Campbell,D.E.Loeber and A.J.Tinker,Polymer,20,  
393,1979.
- (104) D.S.Campbell,P.G.Mente and A.J.Tinker,Int.Rubb.Confer.  
Nuremberg,1980.
- (105) D.S.Campbell,D.J.Elliot and M.A.Wheelans,N.R.Technol.,  
9,21,1979.
- (106) D.J.Elliot,Natural Rubber Systems in"Developments in  
Rubber Technology"(Eds.A Whelan and K.S.Lee),Vol.3,  
Applied Science Publishers,1982,p.203.
- (107) D.S.Campbell,Br.Polym.J.,5,55,1973.
- (108) A.Ghaffar,C.Sadromogaghegh and G.Scott,Eur.Polym.J.,  
17,941,1981.
- (109) G.Scott and E Setoudeh,Eur.Polym.J.,18,901,1982.
- (110) C.Sadromogaghegh,G.Scott and E Setoudeh,Eur.Polym.  
J.,18,1002,1982.
- (111) C.Sadromogaghegh,Thesis Ph.D.The University of Aston  
in Birmingham,1979,p.54.
- (112) Rheovibron Manual.
- (113) J.H.Briston,Ed."Plastic Films",p.21.
- (114) D.J.Elliot,N.R.Technol.,12(3),59,1981.
- (115) Weissenberg Rheogoniometer Manual.
- (116) S.Ewing,"Instrumental Methods of Chemical Analysis",  
McGraw Hill,1960,p.82.
- (117) F.H.Lohman,J.Chem.Ed.,32,155,1955.
- (118) D.Kaplan and N.W.Tschoegl,"Recent Advances in Polymer  
Blends,Grafts and Blocks"(Ed.L.H.Sperling),Plenum  
Press,New York,1974,p.415.

- (119) R.A.Baxter, "Thermal Analysis" (Eds. R.F.S. Schwenker and P.D. Garn), Academic Press, New York, 1969, p.69.
- (120) Instruction Manual for the Stanton Redcroft Differential Thermal Analysis Model 671.
- (121) Enraf-Nonius Manual, Delft, Holland.
- (122) British Standard Institution, BSI No.2782, London.
- (123) R.J.Seward, Rubb.Chem.Technol., 43, 1, 1970.
- (124) W.D.Bascom, Rubb.Chem.Technol., 50, 875, 1977.
- (125) P. J. Corish, Rubb.Chem.Technol., 40, 324, 1967.
- (126) E.Niki, C.Deker and R.Mayo, J.Polym.Sci.Polym.Chem.Ed., 11, 2813, 1973.
- (127) L.F.Ramos-De Valle, Rubb.Chem.Technol., 55(1), 1341, 1982.
- (128) A.I.Medalia, R.R.Juungel and J.M.Collins, Carbon Blacks in "Developments in Rubber Technology" (Eds. A.Whelan and K.S.Lee) Vol.1, Applied Science Publishers, 1979, p.151.
- (129) F.Buche and J.Halpern, J.Appl.Phys., 35, 3142, 1964.
- (130) F.Buche, "Physical Properties of Polymers", John Wiley and Sons, New York, 1962.
- (131) E.M.Dannenberg, Trans.Inst.Rubb.Ind., 42, T.26, 1966.
- (132) L.F.Ramos-De Valle and L.L.Ramirez, Rubb.Chem.Technol., 55(5), 1328, 1982.
- (133) L.Mullins, Effect of Fillers in Rubber in "The Chemistry and Physics of Rubber-like Substances", (Ed.L.Bateman), Maclaren and Sons Ltd, 1963, p.304.
- (134) L.M.Studebaker, Compounding with Carbon Black in "Reinforcement of Elastomers", (Ed.G.Kraus), Interscience Publishers, 1965, p.346.

- (135) L.E.Nielsen, Trans. Soc. Rheol., 13, 141, 1969.
- (136) B.B.Boonstra, Reinforcements by Fillers in "Rubber Technology and Manufacture" (Eds. C.M. Blow and C. Hepburn), Butterworth Scientific, London, 1982, p.269.
- (137) H.W.Greensmith, L.Mullins and A.G.Thomas, Strength of Rubber in "The Chemistry and Physics of Rubber-like Substances", (Ed. L. Bateman), Maclaren and Sons Ltd, 1963, p.298.
- (138) A. Van Rossem, "Rubber" Service, The Hague, 1958, p.138
- (139) C.C., McCabe, Trans. Soc. Rheol., Vol. 4, 1916, p.335.
- (140) G.M.Bartenev and N.V.Zakharenko, Colloid. J. USSR., 24, 101, 1962.
- (141) A.Einstein, Ann. Phys., 19, 289, 1906.
- (142) E.Guth and O.Gold, Phys. Rev., 53, 322, 1938.
- (143) C.C.McCabe, Rheological Behaviour of Filler Reinforced Compounds in "Reinforcement of Elastomers" (Ed. G. Kraus), Interscience Publishers, 1965, p.277.
- (144) B.B.Boonstra, Reinforcement in Polyethylene in "Reinforcement of Elastomers", (Ed. G. Kraus), Interscience Publishers, 1965, p.534.
- (145) G.M.Bristow and W.F.Watson, Mastication and Mechanochemical Reactions of Polymers in "The Chemistry and Physics of Rubber-like Substances" (Ed. L. Bateman), Maclaren and Sons Ltd, 1963, p.435.
- (146) H.Staudinger and H.F.Bondy, Rubb. Chem. Technol., 5, 278, 1932.
- (147) L. Bateman and W.F.Watson. Rubb. Chem. Technol., 27, 2, 1954.
- (148) G.Scott, "Atmospheric Oxidation and Antioxidants", Elsevier Publishing Company, Amsterdam, 1965, p.252.

- (149) Ref.148, p.382.
- (150) D.J.Elliot, "Developments in Rubber Technology", (Eds. A.Whelan and K.S.Lee), Vol.3, p.59.
- (151) A.S.Kuzminskii and L.I.Lyubchanskaya, Rubber Abstr., 36, 5668, 1958.
- (152) C.Sadrmohaghegh, G.Scott and E.Setoudeh, Eur.Polym.J., 19, 81, 1983.
- (153) I.R. Lloyd, Plast.Rubb.Proc.Appl., 1, 351, 1981.
- (154) E.H.Merz, G.C.Claver and M.Baer, J.Polym.Sci., 22, 325, 1956.
- (155) C.B.Bucknall, "Toughened Plastics", Applied Science Publishers Ltd., London, 1977, p.63.
- (156) A.Ghaffar, A.Scott and G.Scott, Eur.Polym.J., 11, 271, 1975.
- (157) E.R.Wagner and L.M.Robeson, Rubb.Chem.Technol., 43, 1129, 1970.
- (158) R.Buchdahl and L.E.Nielsen, J.App.Phys., 2, 482, 1950.
- (159) C.B.Bucknall and R.R.Smith, Polymer, 6, 437, 1965.
- (160) S.Newman and S.Strella, J.App.Polym.Sci., 9, 2297, 1965.
- (161) J.P.Daugherty, "Ethylene-Propylene Rubbers", Introducing Rubber Technology Course. Enjay Polymer Lab., Linden, New Jersey, 1969, p.3.
- (162) G.V.Hutson and G.Scott, Chem.Ind., 725, 1972.
- (163) D.Mellor, A.Moir and G.Scott, Eur.Polym.J., 9, 219, 1973.
- (164) G.Scott, Polym.Plast.Technol.Eng., 11(1), 1, 1978.
- (165) F.Gugumus, Developments in the UV-stabilisation in "Development in Polymer Stabilisation" (Ed.G.Scott), Vol.1, Applied Science Publisher, 1979, p.264.
- (166) F.Tudos, G.Balint and T.Kelen, Effect of various photo-stabilisers in the photo-oxidation of polypropylene in "Developments in Polymer Stabilisation", (Ed.G.Scott), Vol.6, Applied Science Publishers, 1983, p.121.

- (167) Ref.148,p.275.
- (168) S.Al Malaika,K.B.Chakraborty and G.Scott,"Developments in Polymer Stabilisation", (Ed. G.Scott), Vol.6,1983,p.73.
- (169) P.Vink,"Developments in Polymer Stabilisation", (Ed. G.Scott), Vol.3, Applied Science Publishers,1980,p.120.
- (170) P.Vink and T.A.Van Veen, Eur.Polym.J., 14,533,1978.
- (171) D.J.Carlsson and D.M.Willes, Macromol., 2,597,1969.
- (172) F.Gugumus,"Development in Polymer Stabilisation" (Ed. G.Scott), Vol.3,1980,p.280.
- (173) S.Al Malaika and G.Scott,"Degradation and Stabilisation of Polyolefins", (Ed.N.S.Allen), Applied Science Publishers,1983,p.299.
- (174) S.Al Malaika and G.Scott, Eur.Polym.J., 19(3),241,1983.
- (175) G.Scott,"Developments in Polymer Stabilisation", (Ed. G.Scott), Vol.1, Applied Science Publishers,1979,p.309.
- (176) J.L.Bloxham,"Reclaim Rubber, its Developments, Applications and Future", Maclaren and Sons Ltd,1962,p.86.
- (177) N.P.Chopey, Chem.Eng., 80,54,1973.
- (178) M.D.Burgogne, G.R.Leaker and Z.Kretic, Rubb.Chem. Technol., 49,375,1976.
- (179) A.A.Phadke, A.K.Bhattacharya, S.K.Chakraborty and S.K. De, Rubb.Chem. Technol., 56,726,1982.
- (180) W.L.Hawkins and F.H.Winslow, Antioxidant Properties of Carbon Black in "Reinforcement of Elastomers" (Ed.G. Kraus), Interscience Publishers,1965,p.363.
- (181) R.W.Gray and N.G.McCrum, J.Polym.Sci., A<sub>2</sub>, Z,1329,1969.
- (182) P.G.Kelleher and B.D.Gesner, J.App.Polym.Sci., 11,1731, 1976.

(183) Ref.155,p.209.

(184) Ref.148,p.287.