



If you have discovered material in AURA which is unlawful e.g. breaches copyright, (either yours or that of a third party) or any other law, including but not limited to those relating to patent, trademark, confidentiality, data protection, obscenity, defamation, libel, then please read our [Takedown Policy](#) and [contact the service](#) immediately

The Mathematical Modelling of the Environmental
Performance of Buildings as an Aid in the Design
Process

R.H. BYRD

Submitted to the Council for National Academic
Awards for the degree of Doctor of Philosophy.
The research described was performed in the
City of Birmingham Polytechnic in collaboration with
the University of Aston in Birmingham.

April 1981

Preface

I would like to acknowledge the advice, interest and encouragement of my supervisors, Alan Hildon and Jean Heap. I am grateful to Jim Howrie, Head of the Birmingham School of Architecture, for the provision of research facilities and to David and Steve for their technical back-up.

I am also thankful to Dean Hawkes, Director of the Martin Centre, for discussions on 'user-response' and to Geoffrey Broadbent, Professor of Architecture at Portsmouth Polytechnic, for discussion on 'typologies'.

Financial assistance from the Science Research Council is gratefully acknowledged.

While registered as a candidate for the degree of Doctor of Philosophy the author has not been a registered candidate for any other award neither has any material contained in this thesis been used in any other submission for an academic award.

The Mathematical Modelling of the Environmental Performance of Buildings as an Aid in the Design Process

R.H. BYRD

Abstract

This thesis is a theoretical study of the accuracy and usability of models that attempt to represent the environmental control system of buildings in order to improve environmental design.

These models have evolved from crude representations of a building and its environment through to an accurate representation of the dynamic characteristics of the environmental stimuli on buildings. Each generation of models has had its own particular influence on built form.

This thesis analyses the theory, structure and data of such models in terms of their accuracy of simulation and therefore their validity in influencing built form. The models are also analysed in terms of their compatibility with the design process and hence their ability to aid designers.

The conclusions are that such models are unlikely to improve environmental performance since:

- a the models can only be applied to a limited number of building types,
- b they can only be applied to a restricted number of the characteristics of a design,
- c they can only be employed after many major environmental decisions have been made,
- d the data used in models is inadequate and unrepresentative,
- e models do not account for occupant interaction in environmental control.

It is argued that further improvements in the accuracy of simulation of environmental control will not significantly improve environmental design. This is based on the premise that strategic environmental decisions are made at the conceptual stages of design whereas models influence the detailed stages of design.

It is hypothesised that if models are to improve environmental design it must be through the analysis of building typologies which provides a method of feedback between models and the conceptual stages of design. Field studies are presented to describe a method by which typologies can be analysed and a theoretical framework is described which provides a basis for further research into the implications of the morphology of buildings on environmental design.

Contents

	Page
Introduction	ix
Chapter 1. Framework for Research	1
1.1 Introduction	1
1.2 The Conflict in Research for Producing Models that Aid Design	3
1.3 Trends in Research	6
1.4 Trends in Modelling	7
1.5 The Need for a Framework to Relate Research to Design	9
1.6 Summary	11
Chapter 2. <u>Theory of Models in Design</u>	
2.1 Introduction	12
2.2 Classification of Environmental Models	13
2.2.1. The Dimensions of a Classification Matrix	13
2.2.2. Types of Models Within Classifi- cation Matrix	14
2.2.3. Trends within Classification Matrix.	16
2.3 Prescription vs. Evaluation	17
2.4 Theory of Models in Design	19
2.4.1. Alexander's Model of the Design Process.	19
2.4.2. Determinism, Atomism and the Oedipean Effect.	20
2.5 Prospects for Environmental Modelling	23
2.6 Summary	25
Chapter 3. <u>The Structure of Models of the Environmental Control System</u>	
3.1 Introduction	27
3.2 Theories of Environmental Control	28
3.3 The Conventional Structure of Models of Environmental Control.	31
3.4 Trends in Environmental Control.	33

	Page	
3.5	The Cybernetic Model of Environmental Control	36
3.5.1.	Feedback Systems in Environmental Control	36
3.5.2.	Information for Feedback Loops	37
3.6	A Conceptual Model of Environmental Control	38
3.7	Prospects for Accurate Simulation of Environmental Control	39
3.8	Summary	40
Chapter 4.	<u>Data for Occupant Comfort and Response</u>	
4.1	Introduction	42
4.2	Comfort Conditions	43
4.3	Measures of Comfort	44
4.3.1	Laboratory Studies	45
4.3.2	Field Studies	46
4.3.3.	The Dimensions of Occupant Perception	48
4.3.4:	Summary of Experimental Methods for Obtaining Comfort Data	49
4.4	Interaction in Environmental Control As a Measure of Comfort	50
4.5	Data for the threshold of Active Response	51
4.6	Information Used for the threshold of Response	53
4.7	Summary	55
Chapter 5.	<u>Data for Describing the Climatic Stimuli on Buildings</u>	
5.1	Introduction	57
5.2	Accuracy of Data vs. Purpose of Model	58
5.3	Conventional Description of Climatic Data	61
5.4	Accurate Descriptions of the Climatic Elements in the Thermal Environment	63
5.4.1	Building/Climate Interaction	63
5.4.2	Longwave Radiation	64
5.4.3	Convective Heat Transfer	65
5.4.4	Heat loss by Air Infiltration	67
5.5	Building type and Climatic Data.	68

Chapter 5 Contd.		Page
5.6	Climatic Data for Daylighting	70
5.7	Summary	71
Chapter 6.	<u>Limitations of Environmental Models</u>	
6.1	Introduction	73
6.2	Prescriptive Models	74
6.3	Evaluative Models as Design Aids	79
6.4	Research Tools	84
6.5	Prescriptive vs. Evaluative Models	86
6.6	Summary	87
Chapter 7.	<u>Environmental Models in the Design Process</u>	
7.1	Introduction	89
7.2	Strategy vs. Tactics	90
7.3	The Conventional Role of Environmental Models in Design	91
7.4	Theories of the Design Process	93
7.4.1	Design Method	93
7.4.2	Linguistic and Evolutionary Analogies	95
7.5	Building Typologies	96
7.6	Summary	98
Chapter 8.	<u>The Environmental Performance of Building Typologies</u>	
8.1	Introduction	100
8.2	Design Theory and Holistic Analysis.	101
8.3	An Alternative Measure of Building Performance	103
8.4	Environmental Performance Inter and Intra Building-type	105
8.5	Energy Consumption Inter and Intra School Typologies: Field Studies	106
8.6	Inter and Intra Building Type Analysis vs. Evaluative Models.	109
8.7	Further Research	111
8.8	Summary	112

	Page
Chapter 9.	<u>The Application of Building Typologies as an Aid in the Design Process</u>
9.1	Introduction 115
9.2	Classification of Building Typologies 115
9.2.1.	A Classification System 115
9.2.2.	Matrix Dimensions 116
9.2.3.	Trends Within the Matrix and Artificial Evolution. 119
9.3	Use of Typologies During Design. 121
9.3.1.	Early stages of Design 121
9.3.2.	Typologies at the Later Stages of Design 124
9.3.3.	Limitations of Building Typologies 125
9.4	Prospects and Further Research 127
9.5	Summary 128
Chapter 10.	Epilogue: Typologies and Morphologies
10.1	Prospects for Typological Analysis 130
10.2	The Anatomy of Buildings and Evolution of Environmental Modelling 132
Bibliography	135

List of Illustrations

Figure		Page
2.2.1	Classification Matrix for Environmental Models	14
2.2.3	Properties of Models within Classification Matrix	16
2.4.1	Alexander's Model of the Design Process	20
2.5	P.D.I. Model Superimposed on Classification Matrix	24
3.3	Climatic Modification	32
3.5.1	Interaction between Mechanisms and Modes of Environmental Control	36
3.5.2a	Basic Feedback	37
3.5.2b	Adaptive Feedback	38
3.6.a,b & c	Model of the Environmental Control System	39
6.1.1	Typical Models within Classification Matrix.	73
7.2	An Iterative Process of Generating Built Form	91
8.4	Energy Consumption for School Types in Essex C.C.	105
8.5a	School Building Typologies	106
8.5b	Variation in Energy Consumption Inter and Intra Building Types	108
9.2.2.a	Classification Matrix for Building typologies	118
9.2.2.b	Components of Active Environmental Control	119
9.3.1.a & b	Hypothetical Curves of Energy Required for Heavy and Lightweight Buildings Depending on Depth.	122
9.3.2.a,b & c	The Structure of the Control Systems of Three Different Building Typologies	125

Introduction

This thesis presents the findings of an investigation into models that predict the environmental performance of buildings and the role of such models in improving environmental design. However, it does not conform to the conventional structure of theses as it is almost entirely theoretical.

Research in this field has, in the past, concentrated on improving the accuracy of data and the sophistication of simulation, influenced to a degree by the advent of the computer. Within its own frame of reference such research may be productive but, this thesis argues, it does not significantly aid environmental design. Conventional environmental models are both incompatible with the design process and have theoretical limitations that cannot be overcome by refining models within their existing theoretical context. The purposes of this research are therefore twofold: firstly, to analyse the theoretical limitations of existing models and secondly to propose an alternative theoretical framework for environmental modelling.

The original programme for this research (appendix 1) was based on the assumption that conventional theory in environmental modelling was adequate and that a method of improving the compatibility of models with the design process would involve the production of simple rules-of-thumb. This was argued on the grounds that the loss of accuracy inherent in simplified models would be compensated for by

an increase in their convenience of use during design.

This entailed empirical research that compared the accuracy of environmental models of differing complexity in order to measure the loss of accuracy involved in employing simple rules-of-thumb. Simultaneously, questionnaires were sent to practitioners seeking their opinions concerning the convenience of various models during use. The results were intended to be used in finding a suitable compromise in the 'convenience vs. accuracy' argument. The method proposed for daylighting design (appendix 2) is included as it manifests the results of one aspect of such an empirical approach. However, this line of research was terminated on the grounds that:

- a. the limitations of even the most complex, and therefore potentially accurate, models rendered them inaccurate to the extent of being of little aid in improving environmental design
- b. irrespective of the accuracy of conventional environmental models they only have the potential of being 'fine-tuners' to designs where strategic environmental consequences are decided before the models can be employed.

The hypothesis is that such limitations are due to:

- i. inadequate theories of environmental modelling and the environmental control system.

- ii. inappropriate concepts of the cognitive processes involved in design.

The conventional description of the design process has seen the design solution as being generated from the analysis of the design problem. As the role of conventional environmental models is that of analysis they are assumed to be compatible with design. However, more recent descriptions of the design process suggest that the design problem can only be described within the context of a conjectural design solution.

This description of design implies that conventional environmental models will only influence the tactics of environmental design, the strategy being inherent in the conjectural design solution.

This thesis is structured into two main parts. The first part is a theoretical analysis of the limitations of the theory, structure and data of conventional environmental models as well as an analysis of their compatibility with the design process. The second part is concerned with the derivation of a theoretical framework that is intended to aid strategic environmental decisions. This is supported by empirical studies into alternative measures of environmental performance which, although rudimentary, are argued to provide a more rational approach to good environmental design.

Notes on Terminology

Unless otherwise stated the environment is taken to be the thermal, luminous and acoustic conditions in and around buildings. The environmental control system is the combination of the components of a building and its systems that selectively reduce the energy of the environment external to a building in order to provide comfort conditions internally. Control mechanisms are those components of the environmental control system that are designed to be altered (e.g. switches, windows and blinds). Environmental models are mathematical representations of part or parts of the environmental control system. Environmental performance is a measure of the efficiency of the environmental control system.

Design is taken to mean the cognitive process by which three-dimensional form is generated and environmental design is the same process but with special reference to environmental performance.

In the context of this thesis a building type is characterised by its mode of environmental control, in particular its form and fabric. Typology and stereotype are synonymous and describe building types that have a commonly held image. Environmental consequences are those characteristics of environmental performance that are inherent in a particular building type. Building type dependent implies that the particular characteristic under study (e.g. models, data or control-mechanisms) is peculiar to a certain building type and cannot be universally applied.

CHAPTER 1

FRAMEWORK FOR RESEARCH

1.1 Introduction

This chapter aims to both pose the problems that this dissertation is concerned with and describe the framework within which they will be analysed. The fundamental problem being that architectural research concerned with the environmental performance of buildings has had little influence on improving the quality of the built environment. This can be accounted for (Koenigsberger, 1978) by a failure in environmental models, being either inaccurate or incompatible with design, or by a failure on the part of designers through employing models incorrectly (Note 1). This dissertation is more concerned with the former failure since the latter failure, although important, is secondary to increasing the accuracy and compatibility of models in the design process.

The central theme to the thesis is that, in environmental modelling, accuracy is inversely related to compatibility and that the compromise or balance between these two characteristics of a model depends on how one views the cognitive process involved in design.

If, on the one hand, design is seen as a systematic and iterative process of analysis-synthesis then models should be made as accurate as possible as they are assumed, by the definition of the design process, to be compatible with the cognitive process of designing. On the other hand, if design is seen as a process of conjecture-analysis then the balance within models must be towards compatibility as they will only be 'fine-tuners' to a conjecture that has inherent environmental consequences.

The accuracy vs. compatibility argument has been addressed by other workers. For example: 'accuracy vs. convenience' (Hawkes, 1970a), 'strategy vs. tactics' (Page, 1976) and 'prescription vs. evaluation' (Chaddock, 1980).

This dissertation takes up these arguments and analyses them through modelling theory (chapters 2 and 3), the data for models (chapters 4 and 5), the application of models (chapter 6) and the design process (chapter 7).

This analysis serves not only to criticise the failure of existing models of environmental performance but also to develop a framework (chapters 8 and 9) which, it is argued, not only offers a logical approach to environmental design but also bridges the accuracy vs. compatibility paradox.

1.2 The Conflict in Research for Producing Models that Aid Design

The outcome of much research has been the description of building performance by decomposition which, within its own frame of reference, may be valid but does not necessarily aid the designer whose problem is the reverse: composition.

There have been many criticism of this approach, for example, Hillier, Musgrove and O'Sullivan (1972) in a paper entitled "Knowledge and Design" suggested that increased investment in research has proceeded side by side with a deterioration in building quality. This was not because research was not progressing but because it was not considering the relationship between its findings and the design process. A similar criticism came from Koenigsberger (1978) in a paper entitled "Architectural Science for Practitioners" in which he suggested that there was a gulf between 'science' and 'practice'. Architectural Science promoted "designing backwards", design first then evaluate, whereas the design process required "designing forward", evaluate first and then design.

Lawson (1980) sees this as an inevitable conflict that cannot be resolved since design is essentially prescriptive whereas science is predominantly descriptive. While scientific research may help in understanding the present and predicting the future, design is concerned with prescribing and creating the future.

This conflict is not apparent if the design process is seen as being scientific process. For example 'Design Method' Broadbent (1969), which until recently has been the conventional description of design, sees the composition of a design solution as being generated from the decomposition of the design problem. Therefore, environmental models have a clear role in the generation of design as they are part of the decomposing process.

However, 'design method' has been criticised because the generative stage (synthesis) cannot be carried out systematically and alternative theories of the design process suggest that a design problem can only be understood within the context of a design solution, however crude. Therefore, environmental models should not only decompose problems but the knowledge gained from the decomposition should inform in the making of the design 'hypothesis' in the first place.

Steadman (1979) has suggested that the role of environmental models is therefore at two levels. Firstly they predict the performance of a design and secondly, as a result of the prediction, they define the limits of possible designs which the given constraints impose.

March (1976) has put this argument more succinctly in his "P.D.I." (Production, deduction and induction) model of design. Each stage is defined:

Production is the inference of a case from the rule (composition).
Deduction is the application of a general rule to a case (decomposition).
Induction is the inference of the rule from the case (supposition).

Each stage is in succession and by a process of iteration

($P_1 D_1 I_1 P_2 D_2 I_2 \dots$) a design is refined.

However, such a model is hypothetical in environmental design as there is no formal link between deduction and induction. Production requires holistic models (design hypothesis), the results of deduction (environmental models) are atomistic. The only way of completing the cycle is if the stage of induction can formulate holistic suppositions. This is not possible with traditional environmental models which are atomistic as they are concerned with:

- a) only single variables of the physical environment (e.g. heat, light and sound) and
- b) single building elements (e.g. windows or rooms considered in isolation).

Traditional, deductive models which decompose the problems are therefore incompatible with design production. A role for research may therefore be to formulate an inductive framework that can complete the cycle of production, deduction and induction.

1.3 Trends in Research

Previous research in environmental modelling has been concerned with improving the data of models. For example, data for comfort indices (discussed in chapter 4) (e.g. Griffiths, 1975 and Boyce, 1975) and data concerning the climate external to buildings (discussed in chapter 5) (e.g. Greenwood, 1971 and Lacy, 1977). This is consistent with trends in modelling (section 1.5) which have been towards more accurate description of the external climate stimuli and comfort indices.

Within its own terms of reference this research is useful, but in terms of aiding design this work is out of context as the models are atomistic.

However, there is now a trend towards providing models that describe building form and systems on a more holistic basis. This is influenced by computer models which have the characteristics of more sophisticated calculations and the provision of interaction between them. For example: Steadman's (1973) 'graphtheoretic' analysis of the topological arrangement of rectangular rooms, Cole's (1973) research into the interrelationship between buildings and climatic stimuli and Willey's (1978) theoretical model for combining the many variables of the environmental control system.

Although this research has produced research tools and not design aids it nevertheless approaches a link between 'deductive' and 'productive' (P.D.I. model) reasoning. These research tools decompose design while retaining an overview of the whole building and its systems which provides a method of 'inductive' feedback between the 'deductive' and 'productive' phases.

1.4 Trends in Modelling

Trends in modelling can be characterised by the extent to which models attempt to represent the environmental control system. Models have basically evolved from legislative tools to plant sizing through to measuring environmental performance and to research models (cost-effectiveness or dynamic environmental performance) with an ascending order in the accuracy of simulation.

For example, the history of the mathematical modelling of daylight has followed this trend. Kerr (1865) produced a "table of lighting" for calculating compensation for the reduced rental value of a property caused by daylight obstruction. Molesworth (1902) developed this work by producing an orthographic projection of the sky vault with areas of relative sky brightness indicated. A further development of this (Waldram P J and J M, 1923) was the Waldram diagram which allowed isophotal diagrams of daylight factors to be plotted. The Waldram diagram provides the

turning point from assessing daylight for legislative reasons to providing designers with a method for predicting the quantity of daylight in a room. Dufton (1946) developed a set of protractors that predicted the sky components at points within a room with the specific aim of aiding daylighting design. By this stage values of daylight factors had been related to task performance and an empirically based standard sky luminance was used. These protractors were further developed when the CIE overcast sky was agreed to be a more accurate representation of the typically worst conditions of sky luminance.

Further developments in daylight modelling increased accuracy in the representation of occupant perception of lighting. For example, measures of relative indoor illuminance such as the vector: scalar ratio (Lynes et al, 1966) and uniformity of lighting (Saunders, 1969).

Most recent developments have been concerned with the dynamic characteristics of daylighting. For example, representations of the dynamic sky luminance distribution including direct sunlight (Crisp and Lynes, 1979) and also the characteristics of daylighting within a room that determine the threshold of switching action by occupants (Hunt, 1980).

The trend throughout the history of daylight modelling, as well as other components of the environment, has been towards more accurate simulation of the actual conditions of the external and internal environments, most recent

developments being motivated by energy conservation.

The problem in the evolution of environmental models is that each generation is not only influenced by the preceding generation but also inherits its data which is either out of context or too simplistic. For example, models for plant or window sizing presuppose a particular approach to environmental control. This characteristic was inherited by models of environmental performance (section 2.4.2) which likewise made assumptions in the mode of environmental control although they are intended to evaluate different building types on an identical basis. A further example is the data of external climatic stimuli and occupant comfort employed by research tools which has been inherited from models of environmental performance. This data is inaccurate in describing the dynamic characteristics of the external climate and describes 'lack of discomfort' (O'Sullivan, 1978) rather than the threshold for behavioural action.

1.5 The need for a Framework to relate Research to Design

Of the types of models discussed above, this research concentrates on models of environmental performance and research tools rather than legislative tools.

Although there is a trend for these models to become more holistic in the description of building form and systems, there remains an 'applicability gap' (Hillier et al, 1972)

between the research findings and their design application, ie: between deductive and productive reasoning.

This research is concerned with bridging this gap by offering a theoretical framework in the form of a matrix which, on one level, renders an holistic description of the environmental performance of building types. It is argued that even a rudimentary knowledge of the environmental consequences of a building type at the early stages of design is a more logical approach to good environmental design than the post-design evaluation of a type that may have inherently bad environmental consequences. On another level, the matrix also caters for the accurate simulation of environmental performance. It is argued (sections 3.7, 4.7 and 5.5) that the data and structure of models intended to predict environmental performance are building type dependant. The matrix can be used to identify the sensitivities of building types to climatic elements and environmental modification by occupants.

The matrix therefore, forms a link between and aids in both the 'productive' stages of design, as it describes the holistic environmental performance of building types, and the 'deductive' stages as it generates the possibility of accurate simulation.

The designer can therefore, be offered a 'solution field' of known environmental performance at the early stages of design and a logical progression to the accurate evaluation of the design at the later stages of design.

However, the matrix offers only a conceptual framework and requires further research so that it may be refined and evolve by feedback from its practical application.

1.6 Summary

Although the trends in research have been towards the holistic evaluation of buildings and their systems there nevertheless remains a gap between research findings and their application in design. Research findings have been concerned with decomposing design solutions whereas design is concerned with composing design solutions. This research aims to bridge this apparent paradox by offering a theoretical framework which can aid design both at the composing and decomposing stages.

Notes

- 1 See, for example, ABACUS and VALTOS (1979) where identical models that predict energy consumption have been used by both students and practitioners and have resulted in very different recommendations for area of glazing.

CHAPTER 2

THEORY OF MODELS IN DESIGN

2.1 Introduction

Inaccuracies in models have been categorised (Hawkes and Willey 1977) into three causes:

- a theoretical limitations,
- b incorrect or inadequate data,
- c the failure of models to define the full extent of reality.

This chapter is concerned with the first of these causes, although there are no distinct interfaces between the three categories.

In order to discuss the theoretical limitations and how they relate to the accuracy vs. convenience argument (section 1.1) models of environmental performance are classified into:

- i the function of models in design,
- ii the construction of the models.

This classification system offers a framework in which various types of environmental models can be analysed in terms of their potential accuracy, ease of manipulation during

design and use at the early stages of design. Since accuracy is inversely related to convenience, the compromise between the two should vary depending on the stage at which the models are intended to be used during design.

The examples of models discussed in this chapter will be analysed in more depth in chapter six where more emphasis will be put on the limitation of incorrect data and the failure of models to define the full extent of reality (b and c above).

2.2 Classification of Environmental Models

2.2.1 The Dimensions of a Classification Matrix

Echenique (1968) illustrated a matrix which classified models (of all types) into 'what they are made for' and 'what they are made of'. The classification matrix described in this chapter employs the same dimensions but is only a subsystem of Echenique's matrix as it is only concerned with predictive models.

Environmental models have been categorised by Hawkes (1970a) into design aids (Note 1), design assistance by example and legislative tools. Design aids are defined as graphical tools that enable the design to be tested on the drawing board. Design assistance by example is defined as a principle that illustrates a possible solution to a design problem while legislative tools ensure that environmental standards are achieved.

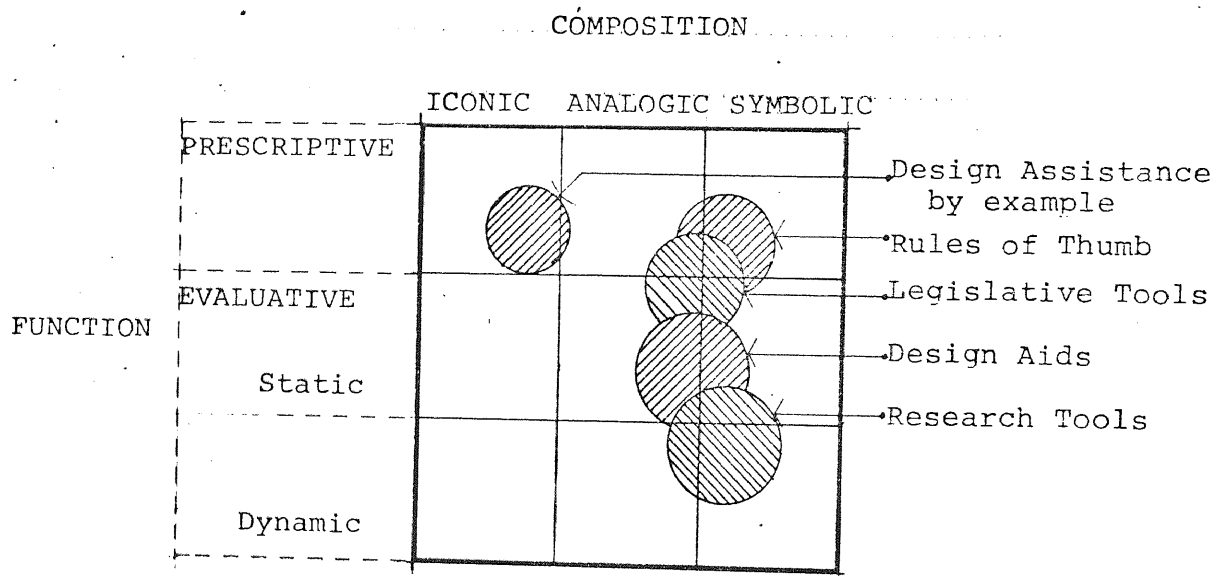

Figure 2.2.1. Classification Matrix for Environmental Mode

the term of example

A further type of model not included in this categorisation are research tools which are intended to be more accurate than design aids but are not necessarily for use on the drawing board.

All these types of environmental models can be classified in terms of their function to either prescribe or evaluate. Evaluative models, which decompose a problem, include both design aids and research tools whereas prescriptive models, which offer a supposition, include design assistance by example.

nce
ols
The proposed matrix for classifying environmental predictive models (figure 2.2.1) has one dimension which describes the model's construction (iconic, analogic and symbolic) and one dimension of the function of models in design (prescriptive and evaluative). Typical models can then be plotted within the matrix.

2.2.2 Types of Models Within the Classification Matrix

al Model
Apart from 'design assistance by example', predictive models can be categorized, with an ascending order of complexity, into:

- a rules of thumb,
- b design aids,
- c research tools.

- a Rules of thumb are generally in the form of simple mathematical equations or graphical analogs which relate, for example, the required window area of a room to either the floor area or window-wall area. An example of such a model, discussed in more detail in section (6.2), is the limitation of the depth of unilaterally daylit offices to 1.75 times the height of the room.

Many rules of thumb have the important property of being both prescriptive and evaluative. For example, the graphical analog (Byrd and Hildon, 1979) for daylight analysis can be used either to generate required window areas or to evaluate the minimum daylight factor.

- b More sophisticated and more common models are design aids. There is no distinct boundary between rules of thumb and design aids, in fact the above example for daylight analysis lies somewhere on the boundary. The essential difference, however, is that the output of design aids is generally in the form of prediction of the environmental conditions inside buildings whereas the output of rules of thumb is generally in the form of 'deemed to satisfy' prescriptions such as window area or room depth. Design aids can be either graphical or mathematical, an example of the former being the BRS daylight factor protractors (BRS, 1964) an example of the latter is the 'admittance method' (London, 1968) for calculating peak summertime temperatures in buildings. However, more complex design aids have been computerised, for example SPEED (Baxter, 1978) which is discussed further in section 6.3.
- c Research tools are more sophisticated and complex than design aids although there is no clear distinction

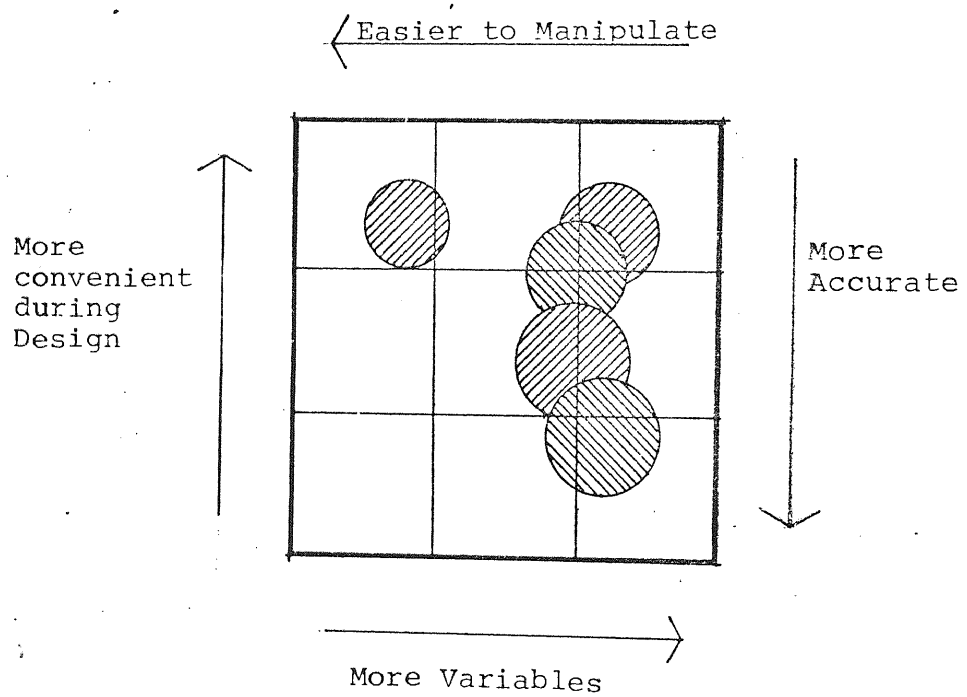

Figure 2.2.3. Properties of Models within Classification Matrix

The dimensions of the matrix are the same as those of figure 2.2.1.

between the two. The essential differences, however, are that research tools have more detailed and dynamic data and the output may not be used for analysing a specific design but for calculating the cost-effectiveness of control systems or improvements to the building fabric.

For example, some research tools (see section 6.4), have the characteristic of relating daylight level within a room to the switching of lights which in turn may be related to heat gains from the lights. Such models require data that describes both the dynamic characteristics of the availability of daylight and the probability of switching control action by occupants.

2.2.3 Trends within Classification Matrix

Within the classification matrix all predictive environmental models can be described and some of their properties analysed. There are no clear interfaces between the types of models and many have dual functions of being either both prescriptive and evaluative or both design aids as well as research tools.

In general, the more potentially accurate models become the more data they require which renders them less use in the early stages of design. Furthermore, the more variables that a model contains the less easy it is to manipulate which makes it less attractive for use in the earlier stages of design. Figure 2.2.3 shows this diagrammatically. Prescriptive-icons are most compatible with the early stages of

design but are less accurate than, say, mathematical research tools which may be highly accurate but are of little use in early design..

The trend towards more accurate research tools (section 1.4) has meant a move away from the easily manipulated generative design aids.

2.3 Prescription vs. Evaluation

The compromise between complexity and convenience is determined by the function of a model and the stage in the design process at which it is intended to be employed. Those models intended to influence the generation of form must aid decisions made at the early stages rather than assess the consequences of decisions that have already been made.

Within the classification matrix the dimension of the function of predictive models has two basic components: prescription and evaluation. Prescriptive models fulfil the role of aiding early design decisions as they do not require data that is only available at the later stages of design when the form and fabric of the building is known. Evaluative models, however, are more accurate but can only be applied at the tactical stages of design and will therefore, only be 'fine-tuners' to a design that has inherent environmental consequences deriving from strategic

decisions taken at the early stages of design.

However, a criticism of prescriptive models is that they are deterministic and show bias to particular building types or modes of environmental control. For instance many rules of thumb assume the area of windows or room proportions which, if applied to buildings that do not comply with these assumptions, will give erroneous results.

This is a problem common to all models as they are generally developed in response to a particular building type (for examples see section 6.6). The criticism of prescriptive models is therefore on two levels:

- a the limited number of variables in generating the solution,
- b the determinism of the models in defining the nature of the solution.

Such an argument has been used to promote evaluative models in aiding design (Hawkes, 1970b). However, it has also been argued (Chaddock, 1980) that evaluative models, although intended to evaluate different buildings on an identical basis, are also deterministic.

This argument is based on the fact that evaluative models have been developed in response to the failures of particular building types. For example, the 'admittance

method' was formulated in response to the problems of overheating in small cellular offices and is inaccurate if applied to other building types.

Not only is the assumption of a building type in a model deterministic but also the data of both the external climate and comfort building-type dependant. These points are discussed further in chapter 4 and 5 but the implication is that dissimilar building types cannot be evaluated on an identical basis.

The argument that models of environmental performance are deterministic can therefore be applied to both prescriptive and evaluative models. Hence, the assumption that there is an increasing order of accuracy from prescriptive models through to design aids and research tools only holds if the models are applied to the building type for which they are compatible.

2.4 Theory of Models in Design

2.4.1 Alexander's Model of the Design Process

Further limitations of models can only be described within a framework that describes the theoretical application of models in the design process. Alexander's (1964). model of the design process is chosen as it provides a convenient and concise method of describing both the application and limitations of models.

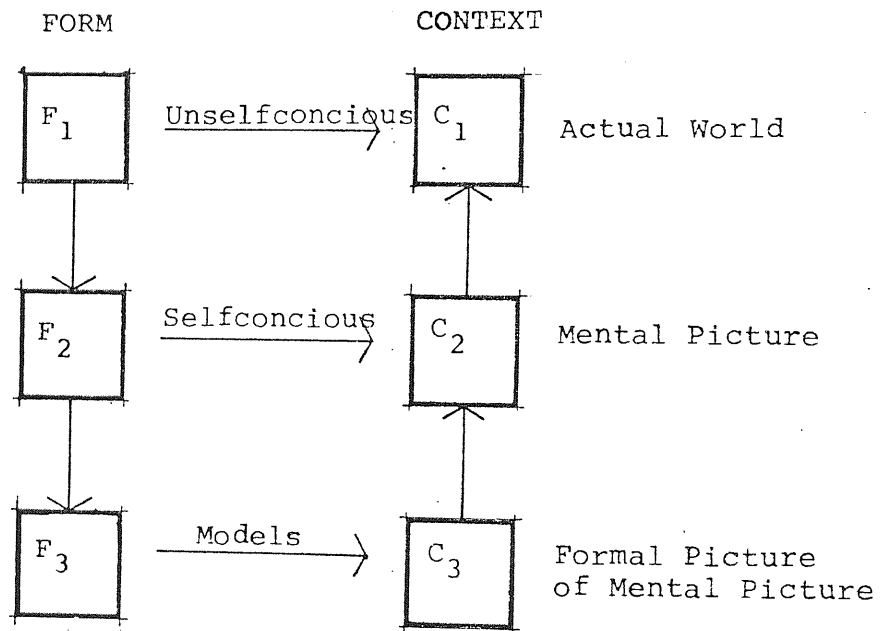

Figure 2.4.1. Alexander's Models of the Design Process
 (after Alexander, 1964)

The model (figure 2.4.1) assumes that a good design is one, in which the form (F_1), responds to the context (C_1) within 'the actual world'.

Alexander suggests that this can be achieved in three ways. Firstly by an 'unselfconscious' process of attempting to relate the context (C_1) to the form (F_1) by trial and error (Note 2). Secondly, by a 'selfconscious' process that relates context to form via a 'mental picture' of both the context (C_2) and form (F_2). And thirdly, by a process of employing 'formal pictures of mental pictures' where a theoretical understanding transfers the evolution of buildings by the two former processes into externalised models. These externalised models, of which models of environmental performance are one type, have the property of being able to be 'run faster' (Steadman, 1975) than the 'actual world' but, being only representations of reality, are unfaithful to it in certain respects.

2.4.2 Determinism, Atomism and the Oedipean Effect

The above framework can be used to illustrate further theoretical limitations which influence the accuracy of models in design. These limitations can be categorised into:

- a determinism,
- b the Oedipean effect and
- c atomism.

a Determinism occurs when models are applied outside the theory or context in which they are constructed. An example, in environmental modelling, is in the application of the 'Daylight Factor Slide-Rule' (Hopkinson and Longmore, 1954) which was intended to predict daylight factors in sidelit rooms. However, the slide-rule makes the assumption that rooms are glazed wall-to-wall, a common occurrence in buildings of that time. Although the slide-rule is accurate within that context it renders erroneous results if applied to rooms with a different composition of glazing.

A further example, is the 'Daylight Indicators' (Arnold, 1977) which, although intended for use in block spacing criteria, favour high rise developments.

Such models can determine the outcome of a design either because the model leads to a particular solution or because a designer may simplify a solution in order to comply with a model (Note 3). Relating this to Alexander's model (figure 2.4.1), the form (F_1) in the 'actual world' determines the 'context' of the 'formal picture' (C_3) and vice versa.

b A further limitation is the Oedipean effect which occurs where models act as theories of the artificial systems they interpret. An example, of this effect occurs in the 'artificial evolution' (March, 1976) of buildings. If the models that are used to generate a solution have the same theoretical basis as the models that evaluate it then the solution will produce a self-fulfilled prophecy.

Examples in environmental modelling are models that can both prescribe and evaluate, for instance daylight

analysis techniques (Byrd and Hildon, 1979). This particular method can be used to prescribe a window area for a given minimum daylight factor and vice versa. However, the evaluative mode³ cannot be used to check the results of the prescriptive mode as this would only produce a self-fulfilled prediction.

Relating this to Alexander's model, the form (F_3), fulfills the requirements of the context (C_3) in the 'formal picture' but this does not necessarily imply that the form (F_1) will fulfill the context (C_1) in the actual world.

c A further limitation in modelling is atomism where it is assumed that a problem can be broken down to its smallest parts, each part can then be solved separately and the fragmentary solutions can be synthesised to produce a single solution. This process incurs two major problems. Firstly, the manner in which the problem is broken down, which inevitably has a bias towards quantifiable criteria. Environmental models are atomistic as they consider not only restricted parts of a buildings, generally windows, but also categorise the environment into thermal, luminous and acoustic components (Note 4).

Secondly, the problem of valuing each fragment in order to synthesise a solution (Broadbent, 1979a). Even if each fragmented model is in itself highly accurate there needs to be an equally rigorous model to synthesize the fragments since the combined accuracy of all the models will only be as good as the least accurate. For example, the results of models for window sizing in the thermal, luminous and acoustic environments will invariably differ and conflict (Markus, 1979). There is little point in

using sophisticated and complex models in this case if the compromised window size is based on arbitrary value judgments.

Inevitably design lore leads to a predominance in the value of one model over the others. For example, the 2% daylight factor requirement for schools has been valued above other considerations, leading to over-fenestration and its consequences.

2.5 Prospects for Environmental Modelling

The classification system (figure 2.2.1) allows not only for the analysis of the advantages and disadvantages in the convenience vs. accuracy argument but also for the analysis of trends and future prospects in environmental modelling.

The trend in environmental modelling (section 1.4) has been towards more descriptive and complex models and away from simple prescriptive models. In figure 2.2.1, this corresponds to a move within the matrix from 'Prescriptive-Icons' to 'symbolic-research tools'. The initial argument for this trend (section 1.3) was based on the belief that more complex models would remain compatible with the design process as this process was seen to be scientific. However, a more recent argument (March, 1976) for increasing the complexity of models is that prescriptive models will be derived from research tools by a process of artificial evolution. This can be illustrated by superimposing March's PDI model (section 1.2) on the classification

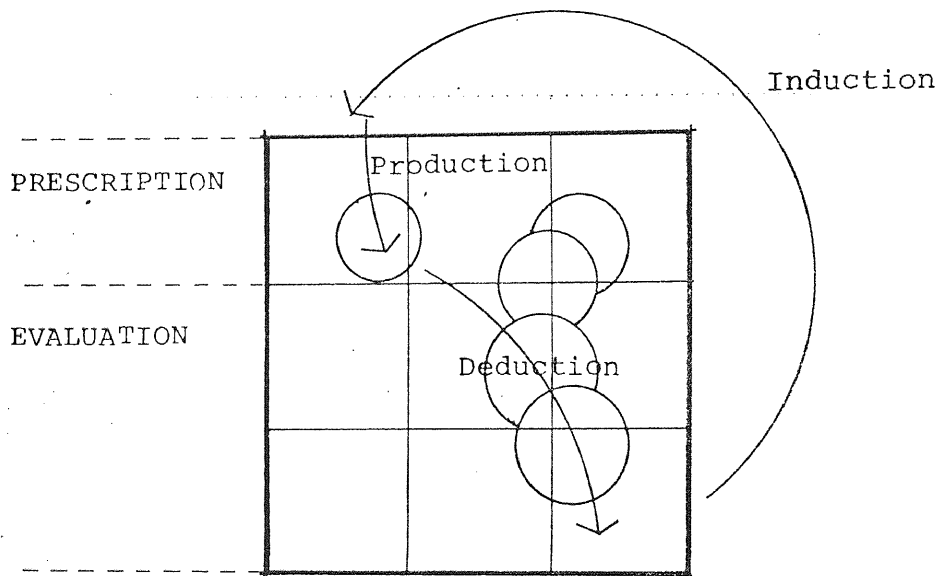

Figure 2.5. P.D.I. Model Superimposed on Classification Matrix

Production: inference of the case from the rule,

Deduction: the application of a general rule to a case,

Induction: inference of the rule from the case.

system for environmental models (figure 2.5): point

The shortcomings of the latter argument can now be analysed in terms of the theoretical limitations discussed in (section 2.4.2).

Deductive reasoning, which is illustrated by a move along the diagonal of figure 2.5, involves the failures both of atomism and determinism. Atomism because the decomposition by deductive reasoning increases along the diagonal and determinism as the decomposition is carried out by models that make assumptions in building types or mode of environmental control.

The process of induction, which is assumed to synthesise the fragments of deductive reasoning to develop models for productive reasoning, has not only the inherent determinism and atomism but is also limited by the Oedipean effect since the research tools both generate and evaluate prescriptive models. In terms of the definitions of productive, deductive and inductive, reasoning (section 1.2), the same models are used to derive the 'case from the rule' as to derive the 'rule from the case'. Thus the assumed iterative process of the PDI model can become a closed loop.

From this analysis it would appear unlikely that conventional research tools will provide the inductive reasoning required to generate prescriptive models for

productive reasoning. However, to argue this point further chapters 3, 4 and 5 analyse research models in more depth in terms of their structure and data.

2.6 Summary

By classifying models of the environmental performance of buildings into a) their function in design and b) their composition, the main arguments concerning the accuracy and compatibility of models within design can be illustrated and the shortcomings analysed.

The classification matrix also demonstrates trends in environmental modelling and certain limitations in current modelling theory. The theory being that by a more holistic deductive process the fragments of a decomposed solution can be synthesised into prescriptive models that will aid in the productive process of design. The limitations of this are that the synthetically evolved prescriptions are derived by models that are both deterministic, atomistic and suffer from the Oedipean effect.

Subsequent chapters extend this analysis by discussing in more detail the determinism inherent in the more sophisticated evaluative design aids and research tools.

- 1 There is a difference between design aids and "Design Aids". The former is a general term for evaluative and prescriptive models while the latter is a particular type of graphical analog discussed further in section 6.
- 2 Broadbent (1973) has suggested a similar process but describes unselfconscious design as 'pragmatic', selfconscious design as 'iconic' and design by formal pictures as 'analogic' or 'canonic'.
- 3 March (1972) cites an example of design lore that suggests that buildings should be as near as possible to a cube in order to minimize heat loss. This can be attributed to over-simplifications in the 'steady-state' heat loss equations.
- 4 A further limitation in environmental modelling which can be categorised into both determinism and atomism is that most research has been carried out on either offices or schools. This implies that the results of such research can only be applied within its given context (see Loudon, 1980).

THE STRUCTURE OF MODELS OF THE ENVIRONMENTAL CONTROL SYSTEM

3.1 Introduction

It was noted in section 2.1 that besides theoretical limitations and inaccurate data the inaccuracy of models could be accounted for by their failure to define the full extent of reality.

The reality that is intended to be represented in environmental modelling is the environmental control system and this determines the structure of models. The control system can be categorised in cybernetic terms, into three basic modes:

- a passive control,
- b closed-loop active control,
- c open-loop active control.

of which different building types have different combinations and predominances.

Most environmental models are only concerned with the passive mode; the form and fabric of the building. While this assumption may be acceptable for plant sizing or

crude prediction of environmental performance, it does not describe the dynamic performance of a building. A description of the active control modes is essential for accurate prediction in particular for research tools concerned with predicting energy consumption or cost effectiveness of control systems or energy conserving devices.

This chapter discusses some theories of environmental control, the trends within environmental control and describes a structure that combines all the modes of control. This structure is employed in section (9.3) to describe the difference in predominance in modes of control of three different building types.

3.2. Theories of Environmental Control

Environmental control was defined (see notes on terminology) as the filtering of the natural environment to produce comfort conditions at the immediate bodily surrounds. At its simplest, environmental control can be achieved by biological homeostatis, eg: vaso-regulation or pupil dilation. However, it is also achieved by voluntary behavioural adaptation, for example seeking shade or altering posture to increase heat loss. It is further achieved by introducing a barrier or combinations or barriers between the bodily surroundings and natural environment, eg: clothes and buildings. Control can therefore be carried out by both voluntary and involuntary

actions as well as barriers.

However, some theories of environmental control do not account for all these control mechanisms and generally only consider the passive mode of control by barriers. The relevance of this being that environmental models which have been intended to represent the environmental control system have only described part of it.

Banham (1969), for example, describes the environmental control system as having three components:

- 1 conservative,
- 2 selective,
- 3 regenerative.

The conservative mode (1) is concerned with the storage and reemission of energy of the external climate to the building while the selective mode (2) admits desirable energy and excludes undesirable energy. The regenerative mode (3) involves the input of supplementary energy to make up that which is lost or unobtainable to the selective and conservative modes. However, these are only passive modes of control as they are manifested in the form and fabric of a building and its plant.

Milne's (1972) theory of environmental control states that the environment is only known to us by the various kinds of energy that impinge the senses and that each sense

responds independently to only one type of energy. The object of environmental control, according to the theory, is to maintain all palpable energy within the maximum and minimum limits of the human comfort range. The control mechanisms being properties of the building fabric: emission, transmission, and absorption.

Not only does this theory only consider the passive mode of control but it also supports the view that the components of the environment, thermal, luminous and acoustic, can be considered atomistically. Although this has been suggested by other workers (eg:, Canter 1975) to be alien to the way people perceive the environment inside buildings.

The assumption that these theories make is that if comfort conditions are obtained there is no need for recourse by building occupants to alter either the building fabric or plant. In chapter 4 this assumption is analysed more deeply, but one of the conclusions is that the ability of an occupant to modify the building's fabric or plant is in itself a measure of comfort.

A further description of environmental control is Ashby's (1956) concept of 'variety reduction' which is used in section 3.5 to derive a descriptive model of the interacting components of the environmental control system. The variety of energy in the natural environment can be reduced in order to provide comfort conditions by a

hierarchy of control actions and mechanisms. The reduction of undesirable energy is achieved by a combination of biological homeostasis, voluntary behavioural adaptation and, in the case of building occupants, the building's fabric. These control actions and mechanisms work by reducing the amplitude of the cyclic characteristics of the natural environment and further reduction or amplification is achieved by the buildings' plant.

This latter theory is a departure from the others as environmental control is seen as being centred around the occupant and not, as the other theories suggest, the occupant being a subsystem to the building. The important characteristic of the concept of 'variety reduction' is that it provides a framework for a model to describe all the components of the control system and therefore the dynamic environmental performance of a building.

3.3 The Conventional Structure of Models of Environmental Control

Olgay (1963) suggested a systematic method for describing the structure of a model that represents the environmental control system with the aim of predicting the environmental conditions inside a building. The theory of environmental control that it was based upon did not consider any form of active control and the method was



Figure 3.3. 'Climatic Modification' (After Hardy and O'Sullivan, 1967)

described as consisting of four stages:

- a a survey of climatic elements,
- b climatic impact in terms of physiology,
- c technological solution to the climate-comfort problem,
- d solutions combined in architectural unity.

This is essentially a normative description of conventional predictive environmental models since an input of meteorological data combined with an input of the description of the buildings form and fabric will render a physical description of the environment that can be checked against a comfort scale.

A similar structure was described by Hardy and O'Sullivan (1967) for modelling the environment control system. The concept of 'climatic modification' assumes two fixed points: the climate external to the building and the internal climate, the building envelope being a filter between the two (figure 3.3). The building's plant is seen as a 'fine-control' in the completion of the modification process.

An example of a model that can be described by this structure is the prediction of peak summertime temperatures (Loudon, 1968). The external climate is described by the solar intensity, air temperature and sol-air temperature while the form and fabric is

id
1671

described by the transmission, emission and reflection of the respective materials. The model then predicts the environmental temperature within the room.

Such a model may be useful for plant sizing as it can predict the worst conditions, but it does not measure the dynamic environmental performance as it cannot account for occupant interaction with the control mechanisms (eg., blinds and openable windows). The summertime temperature predicted by the model may therefore prejudice a design that has a potential for offering comfort conditions due to sensitive control mechanisms available to the occupant.

The essential properties of environmental models described by the concept of 'climatic modification' is that their structure is linear and unidirectional and that there is no interaction between the various mechanisms in the environment control system. There is an implicit assumption that any deficiency in the modifying characteristics of the form and fabric will be supplemented by the plant and not by any occupant involvement in altering the characteristics of the building's envelope or plant.

3.4 Trends in Environmental Control

The structure of environmental models that are described by the concept of climatic modification are deterministic as they presuppose a particular approach to environmental control by assuming building occupants to be inactive in

terms of altering the environmental control system.

While predictions of the environmental performance of building types that employ such modes of control may be accurate, predictions of the performance of alternative building types will be erroneous.

The linear structure of environmental models can accurately predict the environmental performance of building types based on the principles of Integrated Environmental Design (IED). IED building types aim to produce a highly controlled environment by employing the plant alone to supplement the reduction in variety of energy by the building envelope, any occupant interaction being minimized. This is achieved by air-conditioning, permanent artificial lighting (PAL) and unopenable windows.

The theory behind IED is similar to Milne's (1972) theory of environmental control (section 3.2) and assumes that if the thermal, luminous and acoustic environments can be kept within the comfort range then the occupants will be comfortable and therefore, by definition, need no recourse to altering the control mechanisms. In order to achieve such a high degree of control over the components of the environment IED building types utilise the passive aspects of control (restricted window areas) to reduce the variety of the internal climate to a minimum and then extensively employ the buildings' plant to supplement the variety of the internal climate.

However, alternative building types have not been able to depend on supplementary energy either because it is unavailable, for example, in traditional building types, or because of the need to reduce energy consumption. The characteristics of the control systems of such building types involves more than just the passive control of form and fabric but also active controls by feedback from occupants or automatic controls or both.

In traditional building types feedback is from the occupants only and is manifested by alteration to the building envelope. For example, the opening or closing of windows to increase ventilation or reduce the disturbance due to noise. The building's plant being manually controlled, for example, by simple on/off switches for electric lighting and radiator valves for heating.

Other building types that involve feedback are those that employ 'two-tier' control systems where the feedback is from both occupants and electromechanical devices. The purposes of such control systems being to reduce energy consumption by optimising the variety reducing characteristics of the building fabric (eg: automatic blinds) and the output of the plant (eg., automatic dimming of lights).

In conclusion the linear and unidirectional structure of models based on the concept of climatic modification is inadequate in describing any form of feedback control whether by users of 'free-running' building types or the

Environmental Control Mechanisms

Mode of Control	Fabric	Plant	Self	Type of Feedback
ACTIVE			/ / / / /	
Physiological			/ / / / /	
Behavioural	/ / / / /	/ / / / /	/ / / / /	Open Loop
Electro-Mechanical	/ / / / /	/ / / / /		Closed Loop
PASSIVE	/ / / / /			

Figure 3.5.1. Interaction between Mechanisms and Modes of Environmental Control

combinations of users and automatic controls in building types employing 'two-tier', control systems.

3.5 The Cybernetic Model of Environmental Control

3.5.1 Feedback Systems in Environmental Control

The cybernetic model of environment control provides an alternative structure for models as it describes not only the passive control by the form and fabric of a building but also the active feedback control of both occupants and electromechanical devices and integrates all three modes of control.

In cybernetic terms, feedback is described as the output of a system regulating the input of the same system. In terms of environmental control, feedback is the active control actions of occupants or electromechanical devices in regulating the various mechanisms of environmental control (eg., fabric, plant, clothing and activity).

Figure 3.5.1 illustrates the interaction between the modes of environmental control (Physiological and behavioural adaptation, electromechanical control devices and the passive mode) and the control mechanisms (building fabric, plant and self adjustment). Self adjustment includes altering activity, posture, position, clothing and biological homeostatis.

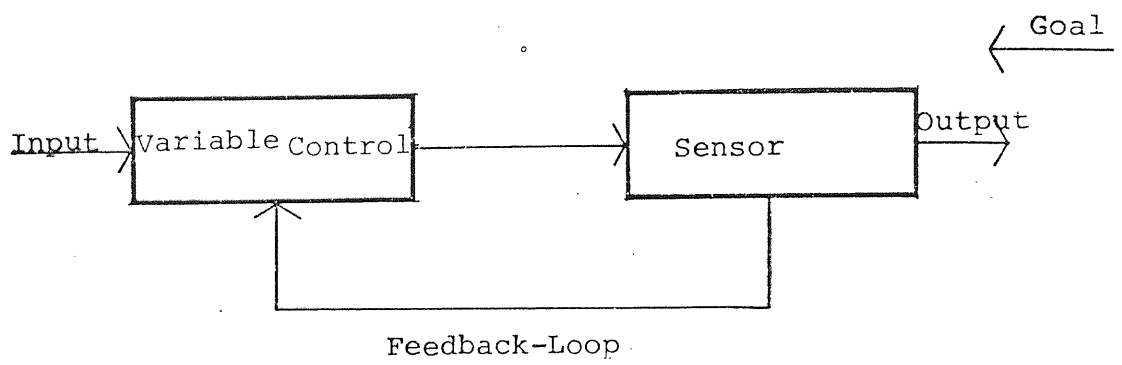

Figure 3.5.2a. Basic Feedback (eg: a thermostat)

3.5.2 Information for feedback loops

Active control can be separated into two distinct modes: adaptive and basic feedback.

The former is associated with occupant control while the latter is associated with the control action of electro-mechanical devices although, in practice, the two modes are interactive.

An example of basic feedback is the action of a thermostat, illustrated in figure 3.5.2a. The temperature is regulated because information from the 'sensor' affects the 'variable control' and determines the level of power input into the system. The system is therefore self-regulating and considered to be 'closed-loop'. An example of an 'open-loop' system, feedback which is not self-regulating, is a radiator valve that relies on a person for its control.

Figure 3.5.2b is a hypothetical representation of adaptive feedback. However, this form of feedback cannot be represented by simple loops since it not only monitors the success of control action but also of the whole strategy. For example, a change within a control action or a change from one control action to another or a change of objectives.

The essential differences between these two forms of feedback is in the information required for control actions. The information required for 'basic' feedback is the state

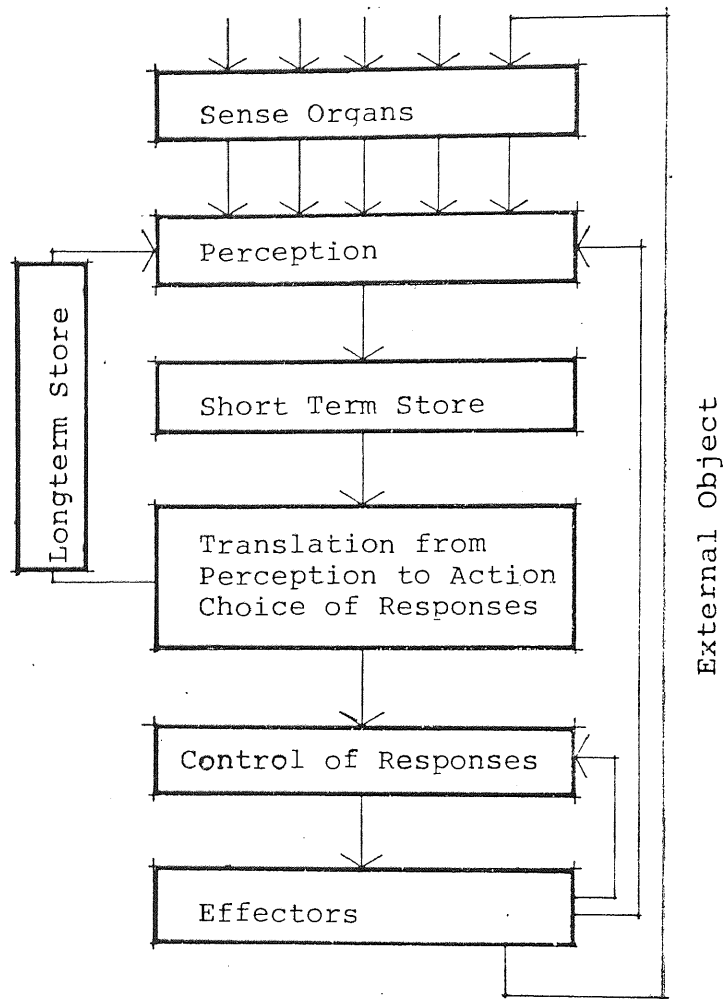

Figure 3.5.2b. Adaptive Feedback (after Welford, 1968)

of the controlled system, disturbance to the system and the results of control action. The information required for adaptive feedback requires a more complex representation of the system's dynamic performance than the simple error signal used in basic feedback. The threshold for control action is based on collective sensory response which relies on memory storage, anticipation and integration of information. This is discussed in more detail in sections 4.5 and 4.6.

This difference in information requirements between the two modes of feedback highlights the fact that electro-mechanical devices can only crudely represent the likely response actions of occupants. The perception of information that signals the threshold for control action for electromechanical devices is concentrated on only a few cues, more usually only one, and cannot be altered. This implies that electromechanical devices are prone to masking. For example, a thermostat placed close to an open window will signal an increase in heating plant output although the purpose of the open window may be to increase the ventilation heat loss. However, the control action of the occupant in this situation would be the opposite (assuming that they are motivated).

3.6 A Conceptual Model of Environmental Control

The above discussion provides the foundations for a model of the environmental control system which has been developed by Willey (1978) and based on Ashby's (1956) work on

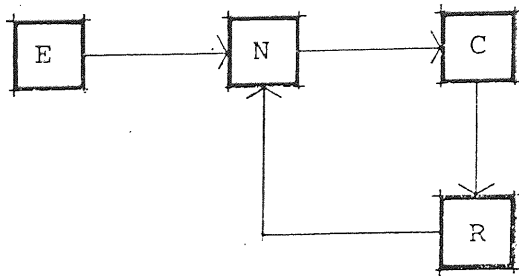

Figure 3.6a.

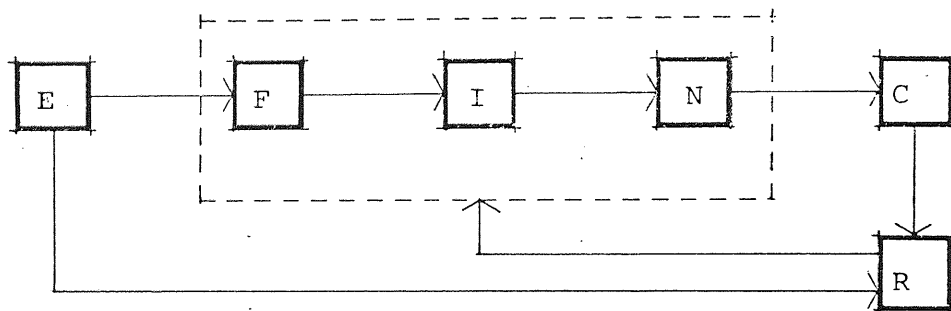

Figure 3.6b.

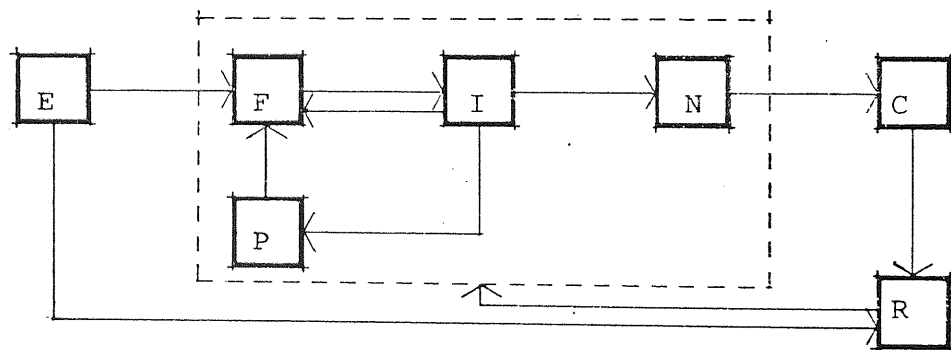

Figure 3.6c Model of the Environmental Control System
(after Willey, 1978)

- R - Regulation
- N - Natural Environment
- E - External Environment
- C - Comfort
- F - Fabric
- I - Internal Environment
- P - Plant

biological homeostatis.

Figure 3.6.a, is a diagrammatic representation of biological homeostatis where regulation, R, on the natural environment, N, reduces the effect of environmental disturbances, E, on the physiological variables, C, which determine the state of comfort.

By introducing the passive control of the building fabric, F, into the system the environmental disturbances are moved further from the immediate bodily surroundings and produce an internal environment I, (figure 3.6.b). The regulation, R, now controls the fabric of the building as well as the natural environment. The natural environment includes such things as clothing, level of activity and posture. The building's plant, P, can now be introduced into the system, however, it does not separate E from C but can be conceived of as an extension to the filtering action of the building fabric. If the plant and fabric have automatic controls then a feedback loop is introduced between the building fabric in the internal environment. Figure 3.6.c, provides a basic model of an environmental control system involving all modes of environmental control and types of feedback discussed in section 3.5.1.

3.7 Prospects for accurate simulation of Environmental Control

The purpose of describing a conceptual model of environmental control is on two levels:

- a to demonstrate the inadequacy of existing models,
- b to offer a structure for accurate simulation of environmental performance.

The reasoning behind the latter purpose, accurate simulation, is to provide a research tool that can describe the dynamic performance of buildings and thus predict such measures as cost-effectiveness or energy efficiency characteristics of various existing or artificially evolved building types. The ultimate objective being to promote building types or certain of their characteristics.

However, the model has two basic theoretical limitations. Firstly it cannot compare buildings that employ different modes of control on an identical basis. The structure of the model must be altered for building types that have a different predominance in any mode of control. Secondly the data required for the threshold of control action is different to comfort data, the conventional data used in models.

The latter limitation is discussed in greater depth in chapter 4 where it is argued (section 4.5) that the data is building type dependant as occupant response is influenced by the availability and efficiency of the mechanisms of environmental control.

3.8 Summary

Occupants play a large role in determining the environmental performance and energy consumption in a building. For simple

design aids or models for plant sizing it may be adequate to ignore this effect and consider only the passive mode of environmental control in isolation to the active modes. But for more accurate evaluative models and research tools, the active modes of control, which include feedback from occupants and electromechanical devices, have a large influence on environmental performance.

Many evaluative models and research tools are based on a linear structure (no provision for feedback) for two reasons:

- a the models have inherited the structure from the more simple models they have evolved from (see section 1.4),
- b most theories of environmental control assume:
 - i that occupants respond to the different components of the environment independently,
 - ii that a measure of good environmental performance is when occupants do not need to interact with a building's control mechanisms.

A conceptual model, intended for computer application and based on cybernetic theory, was described which can account for all modes of environmental control. Although its structure needs to be altered for different building types, the major limitation of this model is in the description of the information required for the threshold of active response by occupants. The subsequent chapter discusses this in more detail in relation to existing comfort data.

CHAPTER 4

DATA FOR OCCUPANT COMFORT AND RESPONSE

4.1 Introduction

In section 1.4 it was noted that a common failure in modelling is that data used in one generation of models is inherited by the next generation and, being out of context, leads to erroneous results. Such is the failure in data intended to describe:

- a comfort conditions inside buildings and,
- b the threshold for active response by the occupants in altering the mechanisms of environmental control.

The limitations of data describing comfort (a) is that;

- i it is based on single variables taken from physical science,
- ii it assumes that the occupants are comfortable when they choose not to behaviourally modify their environment.

These limitations are discussed further in section 4.3 where it is argued that these assumptions (i and ii above) in the description of occupant comfort led to experiments that were only concerned with occupants whose responses were limited and considered them to respond to the

individual components of the environment (thermal, luminous and acoustic) independently.

Data that describes the threshold for active response (b) has been inherited from data that describes comfort conditions and therefore has the latter's inherent limitations. This implies that data for active response, intended for the dynamic modelling of environmental performance, assumes that occupants behave in a similar manner to electro-mechanical devices. For example, photocells or thermostats which respond to a level of one particular physical variable e.g. air temperature or planar illuminance.

However, the purpose of this chapter is not only to describe the limitations of existing data but also to show further variables that should be accounted for in order to provide better descriptions of both comfort conditions and the threshold for active response.

4.2 Comfort Conditions

It was argued in section 3.2 that conventional theories of environmental control assume that if comfort conditions are obtained within a building then the occupants need no recourse to alter either the building fabric or plant. There is also the assumption (e.g. Milne, 1972) that comfort conditions can be achieved in each component of the environment independently providing that the level of each

environmental component is within certain upper and lower limits.

Within this frame of reference experiments that obtain comfort indices are justified in relating single physical variables (eg. temperature, illuminance or sound level) to comfort ratings and in performing experiments in situations where the respondents cannot alter their environment.

The logical conclusion of such studies is to produce buildings based on the principles of Integrated Environmental Design in which the levels of the environmental components do not vary and there are no environmental control mechanisms available to the occupants. However, such building types have been criticised (eg. Haigh, 1977 and Gerlach, 1974) for not providing comfort conditions on the grounds that a better measure of comfort is the variation, within certain limits, rather than levels of environmental conditions.

4.3 Measures of Comfort

The following subsections compare some methods of obtaining indices of occupant comfort (laboratory studies, field studies and multi-dimensional scaling) in terms of the number of physical variables being measured and the control that the respondents have over the physical environment during experimentation.

4.3.1 Laboratory Studies

The characteristics of laboratory studies in determining comfort indices are that single physical variables are taken as measures of a respondent's perception. These measurements were carried out under controlled conditions and the lack of discomfort or performance of a task was related to a physical variable. For example, Weston (1949) or Blackwell (1970) were concerned with the performance of visual tasks related to the size of detail and luminance contrast of images on a plane. In the thermal environment measurements were carried out in climate chambers (eg. Fanger, 1970) to produce indices of thermal comfort which related physical variables such as air temperature, humidity and air velocity to comfort rates depending on level of clothing and activity.

An interesting aspect of many such experiments that were carried out under controlled laboratory conditions is that different experimenters produced differing results, for example, the many different thermal indices listed by Givoni (1969). Although there is no reason to suggest that the methodologies used by one experimenter were more or less precise than those used by any other. This suggests that attempting to represent the dimensions of occupant perception by a single or restricted number of physical variables is inadequate.

A further criticism of laboratory and climatic chamber studies is that they create an artificial environment in

which response will be unrepresentative. For example, Fanger's (1970) climate chamber studies were stringent as they did not allow adjustment to clothing and posture in the way it may be carried out in 'real life'. Furthermore, laboratory respondents are unlikely to show the variation in response that may be shown in 'real life' as they are voluntary and exposed to the experiment for short periods of time.

4.3.2 Field Studies

It was similar criticisms to those mentioned above that promoted field studies as a method for measuring the relation between the physical variables of the environment and the dimensions of perception. The advantage being that field studies have no control over the physical environment or the respondent. This is at once the weakness and strength of field studies since respondents will behave normally but there will remain variables in the physical environment that are unaccountable.

An example of this conflict is the difference in results between laboratory studies (Balder, 1957) and field studies (Saunders, 1969) concerning preferences for illuminances. The former studies showed a preference for higher illuminances. One of the factors that could have contributed to this difference is the type of luminaires used. In the laboratory studies respondents were protected from glare whereas the fieldwork took the luminaires as they existed.

A further example of the limitations of field studies, due to the inability to control or account for all variables, is Brundrett's (1976) study on the window opening habits of families on two housing estates. A correlation was shown between window opening and external humidity on one housing estate, and mean external temperature on the other estate. However, the survey did not report that it took into account that the opening or closing habits may be related to either the fear of rain or security purposes, for example.

Most field work has been carried out by studying the relationship between subjective response and single physical variables in each independent component of the environment. However, more useful information may be obtained if physical variables from the different components of the environment are considered simultaneously.

For example, Langdon (1966) and Manning (1965) obtained useful evidence that people's attitudes, prejudices and past experience play a large part in subjective appraisal.

But because this type of field work still considered each component of the environment in isolation it has been criticised (Canter, 1975) on the grounds that it seeks independent dimensions in people's perception which is contrary to the way in which people interact with the environment inside buildings. Keighley (1970) has also suggested that where there is a general dissatisfaction with the environment, the rating of any one aspect will be

lower than any other and vice versa.

4.3.3 The dimensions of occupant perception

Both laboratory and field studies have been concerned with establishing relationships between single physical variables and subjective response, the limitations of which have been discussed above. To overcome these limitations systematic techniques of uncovering further dimensions of response have been put forward; Factor Analysis and Multi-Dimensional-Scaling (M.D.S.) for example.

However, existing M.D.S. experiments have been concerned with those dimensions within a particular component of the environment (thermal, luminous and acoustic) and have not tried to inter-relate the dimensions of response between these categories. For example, in the luminous environment, Flynn et al (1973), in measuring the effects of interior lighting on impression and behaviour, found the dimensions in luminous perception to be:

- a perceptual clarity (brightness/dim)
- b evaluation (overhead/peripheral)
- c) spaciousness (uniform/non-uniform)

In the thermal environment Griffiths (1975) suggests that the dimensions of thermal experience are:

- a comfort (thermal index but not asym^metry)
- b warmth (thermal index including asym^metry)
- c humidity
- d a factor representing freshness.

Inevitably there is a bias towards quantifiable measures of the physical variables to which the subjective dimensions can be related. However, besides the criticisms of considering the components of the environment in isolation, interaction with the environment is not necessarily on a dimensional basis. Canter (1975) has suggested that by asking people to respond to a particular aspect of the environment brings on a level of awareness which does not exist in every day life. The dimensions of perception derived from M.D.S. may therefore not measure the overall experience but just those aspects that can be discriminated from each other.

4.3.4 Summary of experimental methods for obtaining Comfort data

The measures of comfort obtained from the methods discussed above comprise the conventional measures of environmental performance. The Building Performance Research Unit (1972), for example, has employed the daylight factor, an absolute level of artificial illumination, the environmental temperature and energy consumption (which makes assumptions in comfort temperatures) to describe the environmental performance of buildings. In section 4.3.1 to 4.3.3 it has

been argued that these measures are only crude descriptors of comfort, and hence environmental performance, for four main reasons:

- a each environmental component (thermal, luminous and acoustic) is considered in isolation,
- b the number of variables considered to describe occupant perception is restricted (with the exception of M.D.S.),
- c the measures of comfort are all taken from physical science (an alternative measure will be discussed in section 4.4),
- d each physical variable intended to describe comfort is considered only in terms of levels (with the exception of M.D.S.) and not variation in levels.

4.4 Interaction in environmental control as a measure of Comfort

With the assumption that any form of occupant control should be minimised, comfort experiments on passive occupants appear justified. The aim of laboratory tests, field tests or M.D.S. is therefore to determine physical descriptors which, when achieved by a given environmental control system, reduce any necessity for occupants to behaviourally alter their environment.

This assumption embodies a form of determinism that assumes that occupants do not wish to interact with their environment and that comfort conditions can only be achieved when there is no need for occupants to revert to active control of environmental control mechanisms. This

is contrary to certain research findings which suggest that a determinant of comfort is the degree to which occupants may interact with their environment. For example, Canter (1975) has suggested that the degree to which a person is able to act upon or modify a building may well influence his preference for it. A further example is Haigh's (1977 and 1980) work on the environmental performance of building types in which she argues that a further measure of building performance could be its capacity for modification. This includes the range of environmental control mechanisms such as opening windows, adjusting thermostats and blinds and the responsiveness of the fabric to the changes which they effect.

This measure of comfort is discussed further in section 8.3 where a method for its quantification is discussed.

4.5 Data for the threshold of active response

This chapter has considered the data for comfort conditions separately to data for the threshold of active response.

However, this is in practice an artificial separation particularly in the light of section 4.4 which suggests that comfort is determined, to an extent, by the level of response in modifying the environment. At this point the discussion concerning data can be considered within the framework of the structure of models (section 3.6). Referring to figure 3.6c the determinants of comfort, C, must embody not only the dimensions of occupant perception, discussed above, but also

data concerning the likely threshold of occupant behavioural action, R. The subjective measures that are based on variables taken from physical science are inadequate in predicting the likelihood of occupants modifying their environment.

Existing models that attempt to represent occupant behavioural response employ data that is based on single physical variables which can predict the response of electro-mechanical devices such as thermostats or photocells but are unrepresentative of the threshold of response by occupants. For example, Baxter's (1979) experiments on the economics of photo-electrically controlled lighting assumed that the threshold for the switching of lights by occupants is related to an absolute level of illumination on the working plane. This assumption is also made in the Cambridge environmental model (Hawkes, 1976a) where the duration of use of artificial lighting is included in heat balance calculations. Hunt (1980) has proposed that the minimum daylight factor be used as a measure for the threshold of switching action. Although this measure was chosen as a result of extensive field work, the only alternative measures considered were the geometric and arithmetic means of the daylight factors. Thus the restricted number of measures considered, all of which are measures of absolute levels of illumination, and the assumption that switching only occurs during the extremes of a period of occupation renders this measure crude.

To reduce the behavioural response of occupants to the level of electro-mechanical devices, by assuming that the information required for response to be identical in each case, is erroneous.

Electro-mechanical devices concentrate on the information of one physical variable and are highly accurate in response within their given context but they are not adaptable to alternative contexts. For example, an internal photocell can be very accurate but if placed in an unrepresentative position may provide erroneous information on the level of lighting within a room. On the other hand, occupants will not respond in such a highly predictable way and will inevitably be less accurate but they can adapt to different contexts as they rely on more complex information based on collective sensory response (section 3.5.2).

4.6 Information used for the threshold of response

Occupant perception of the environment involves the use of multiple cues and the response may be either conventional or novel depending not only on collective physical variables (sections 4.3.1 to 4.3.3) but also on a) spatial changes, b) temporal changes, c) the structure and d) the context of the stimuli.

The following examples are research findings which demonstrate the importance of accounting for these characteristics.

- a An example of the relevance of spatial variations in stimuli is in the results of experiments carried out by Griffiths (1975) (see section 4.3.3) where one of the dimensions of thermal experience was related to the asym^metry of heat on the body. Likewise the dimensions of luminous perception mentioned by Flynn et al (1973) included measures of relative spatial illuminance such as uniformity or vector: scalar illuminance ratio.
- b In terms of temporal change, Nicol and Humphreys (1973) showed that besides short term variations in temperature the long term variations, over a matter of days, also influenced thermal comfort. Furthermore the rate of variation is important as it is related to such things as monotony, disturbance and arousal.
- c The importance of accounting for the structure of stimuli has been demonstrated by Gagge et al (1967) whose work showed that people's subjective appraisal of warmth was related not only to the temperature at any particular time but also the sequence of temperatures leading up to it. People anticipate changes in the environment before they occur.
- d The relevance of the context within which environmental stimuli occur is demonstrated by Humphreys' (1975) work on thermal comfort. It was shown that comfort conditions in free-running buildings, within certain upper and lower limits, differed from comfort conditions in heated buildings. An implication of this being that dissimilar buildings cannot be compared on a like basis. A further example is the measurement of noise annoyance (Langdon, 1977)

where it was shown that the Traffic Noise Index was not only related to free flowing traffic but also to the quality of the neighbourhood.

These examples demonstrate that one cannot consider environmental components in isolation to each other neither can absolute levels of physical variables be adequate by themselves in describing the threshold of active response. Other data that includes temporal and spatial variation of the environment as well as its context and structure must be included in order to provide data for models that simulate the dynamic performance of buildings.

4.7 Summary

In section 4.2 it was noted that the type of data and methods of obtaining it was related to the theory of environmental control. The conventional theory assumes that optimum comfort conditions are obtained when a building's occupants are passive and need no recourse to altering the environment.

Experimental techniques for determining the subjective response of occupants to provide comfort data have assumed that:

- i occupants respond to each component of the environment independently and
- ii comfort is achieved only when occupants are passive.

However, this has been criticised (section 4.3.4) as it is alien to the way occupants interact with buildings and, it is argued (section 4.4), a further measure of comfort is the occupant s' ability to alter their environment.

Predictions of either the cost-effectiveness or dynamic environmental performance of buildings which contain control systems where occupants take an active part, require data to predict the threshold of occupant response. The existing subjective measures based on limited physical variables are inadequate as they do not account for spatial and temporal variations or the structure and context of environmental stimuli. Furthermore the response action will be building - type dependent as it is related not only to a hierarchy of available actions but also to the anticipated satisfaction from these actions.

CHAPTER 5

DATA FOR DESCRIBING THE CLIMATIC STIMULI ON BUILDINGS

5.1 Introduction

In section 3.3 it was noted that, in order to predict the environmental performance of a building, models require not only data of occupant comfort (chapter 4) but also a description of the climate external to a building. The conventional method of describing the climate is by standard meteorological data and although this is intended to describe the actual climatic stimuli it is inaccurate and in certain cases inappropriate.

The reason that climatic data is both inaccurate and inappropriate is due to assumptions inherited from cruder models of earlier generations (section 1.4).

Data for plant sizing requires only a crude representation of the typically worst conditions whereas models for predicting environmental performance require more sophisticated data. Research tools, intended to measure the dynamic performance of a building, have inherited many assumptions from these more rudimentary models. The crude data required for plant sizing is adequate within its own frame of reference as safety factors are built into such

models but the data is inadequate and inaccurate for use in more sophisticated models.

However, there is a further inaccuracy incurring in models that require data describing the dynamic characteristics of the external climate. The interaction of buildings with the external climate can be ignored in more rudimentary models but is an important consideration, particularly in terms of the thermal components of the environment, in measuring the actual climatic stimuli on a building. This is due to the climate around buildings being unknown until they are built. This has been described by Page (1976) who suggested that the design of a building has to proceed on the assumption that the environment is known, but the finished building influences the climatological environment for which it has been designed.

5.2 Accuracy of Data vs. Purpose of Model

The required accuracy of climatic data is dependent on the context of the employment of a model. This section compares the characteristics and accuracy of data required for models whose purpose is:

- a plant sizing,
- b measuring environmental performance (steady-state),
- c measuring environmental performance (dynamic).

The essential requirements being an ascending order of accuracy and a trend from describing the typically worst conditions to describing actual conditions.

- a In general, models for plant or window sizing require the least accurate data as they are characterised by measuring the typically worst conditions and including safety factors that render the models inaccurate overall. Any improvement in data being offset by the safety factors. For example, in the sizing of heating plants Cole (1976b) has suggested that due to simplistic assumptions and safety factors oversizing is often in the order of 100 per cent. Furthermore, steady state heat loss calculations may aid in certain decisions concerning the maximum rate of heat loss but they will not model the thermal performance of a building throughout the entire heating season. Any recommendations of optimum building form (e.g. Pike, 1978) based on this data alone will be erroneous.
- b Models that measure environmental performance, in terms of comfort conditions inside buildings, can employ more sophisticated data since they do not include safety factors and hence increased accuracy will not be offset. The structure and data of these models is generally inherited from plant sizing, however the output is in the form of environmental conditions instead of plant capacity of which the latter presupposes a particular approach to environmental control.

c For modelling the dynamic environmental performance the required climatic data should represent the actual environmental stimuli. The reason being that the output of supplementary energy of the building's plant can be minimised by active control that can be highly responsive to changes in the external environment. For example, the likely savings in energy due to automatic dimming of lights can be related to the extra capital cost of such lighting system only if the dynamic characteristics of the external climate can be modelled.

The limitations of climatic data employed for plant sizing or simple measures of environmental performance (e.g. daylight factors or peak summertime temperatures) is that it only considers a limited number of the components of the actual environmental stimuli. For example, models of the availability of daylight are only concerned with diffuse sky illuminance and not direct light from the sun. Models of thermal performance are generally only concerned with dry bulb temperature and do not include the wind speed, cloud cover or atmospheric radiation.

Climatic data, for the thermal environment in particular, that is employed in modelling the dynamic performance of buildings includes more of the elements that comprise the climatic stimuli on buildings and requires a more detailed description of them. However, the disadvantage of such precise data is that it is building type dependent. That is to say, for such an accurate description of the climate

around the building the effect of the building on the climate must already be known. This latter point is discussed further in section 5.5.

5.3 The Conventional Description of Climatic Data

Data for describing the thermal climate is considered separately in this section but its limitations apply to other elements of the climate. For example, similar limitations in daylighting data are discussed in section 5.6.

The essential limitation of conventional thermal data is that:

- a it has a restricted number of variables to describe the climatic stimuli of a building,
- b it does not account for the interaction between climate and buildings,
- c data that includes more than one climatic variable of the thermal climate tends to 'iron out' the inter-relationships between the variables.

Most of these limitations are due to the description of climatic data being fulfilled by standard data available from meteorological stations. This has both advantages and disadvantages as the meteorological stations are on 'green field' sites and hence representative of a

particular region, but the 'raw' macroscale data is out of context with particular building sites.

Improvements on this data have been suggested (O'Sullivan 1970) by accounting for an intermediary climate, which exists between the meteorological climate and building envelope, that can be calculated from the urban density and employed to temper meteorological data.

The interaction between buildings and climate is, however, more complicated and the use of meteorological data tempered by micro-climate data is inadequate in its description of the climatic stimuli on buildings. In section 5.5 it is argued that the shape, length and texture of a building as well as the configuration of its surroundings are important variables in the climate/building interaction.

Meteorological data intended for use in predicting the thermal performance of buildings is in the form of long-term averages. This has the disadvantage of tending to 'iron-out' the inter-relationship between climatic elements (e.g. cloud cover, windspeed and dry bulb temperature).

For simple models, such as the 'degree-day' method, where only one climatic element (dry bulb temperature) is considered, the effect of long-term averaging will be negligible although 'degree-days' are not capable of distinguishing between duration and severity. But for more

complex models that employ, for example, a 'reference year' (Lund, 1974) or an 'example year' (Holmes and Hitchin, 1978) the inter-related data will be distorted. In the latter case, which is chosen from the least abnormal year, it is claimed that it will not suffer from this distortion. But the measure of least abnormality is related to the deviation from the long-term mean which implies that the choice of the example year is influenced by data that is already distorted.

5.4 Accurate Descriptions of the Climatic Elements in the Thermal Environment

5.4.1 Building/Climate Interaction

This section discusses in more detail some climatic components that interact with buildings:

- a longwave radiation,
- b convective heat transfer,
- c air infiltration.

The purpose being to demonstrate that accurate descriptions of these components, for design purposes, require a knowledge of the design as the data is dependent on the characteristics of the building and vice versa.

Cole (1976) has suggested that if any model intends to accurately predict the thermal performance of a building it must include solar radiation, atmospheric radiation,

wind speed/direction, cloud cover and vapour pressure. The influence of the elements on a building depends on both the physical properties (e.g. texture, colour and mass) and geometrical properties (e.g. size, shape, and orientation) of the building envelope.

5.4.2 Longwave Radiation

Little research has been done on longwave radiation and the models that predict it have many oversimplifications. Longwave radiation on a building envelope originates from the atmosphere, the ground and surrounding buildings. Radiation from the atmosphere, principally from clouds, greatly influences the heat loss by radiation from horizontal surfaces. However, while radiation from an overcast sky can be predicted to a reasonable degree of accuracy, partially overcast skies provide a problem as the relationship between cloud cover and atmospheric radiation is non-linear.

In the built environment much of the longwave radiation exchange is on vertical surfaces, hence the radiation exchange between the ground and buildings must be considered alongside radiation exchange from the atmosphere. Radiation exchange from the ground and buildings is almost impossible to predict as it depends on the surface temperatures, the nature of the surfaces, the prevailing climate and the recent history of heating and cooling of the surrounding surfaces. The surface temperature characteristics of the ground and buildings vary considerably;

concrete will differ from grass, an insulated building will have a lower external surface temperature than an un-insulated one and South facing surfaces are generally warmer than those that face North. Hence radiation exchange between the ground and vertical surfaces in the built environment is difficult to quantify.

As radiation exchange between a building and its surroundings is related to the fourth power of the absolute temperatures of the respective surfaces it is represented by a surface coefficient. The coefficient, when multiplied by the temperature difference between the building surface and the surfaces 'seen' by it, will give the radiative component of heat transfer. Large errors can be incurred and, depending on the temperature differences, the error has been shown to be between 10 and 40% (Cole, 1976a).

5.4.3 Convective Heat Transfer

Energy balance on a building's surfaces is also dependent on convective heat exchange. This mode of heat exchange depends on the 'boundary layer' characteristics of a building. There is both a hydrodynamic and thermal boundary layer, the former being the zone between the stationary layer at the surface and the main stream velocity of air.

The latter is the temperature zone between the surface and main stream air temperature. Convective heat transfer is

therefore dependent on the wind velocity and its characteristics (turbulent or laminar) and the temperature difference between the surface and the air. This mode of heat exchange is complex as the hydrodynamic and thermal boundary layers interact. The heat exchange is not only dependent on the characteristics of the building but also on the configuration of the surroundings, the building's shape and length, its orientation, texture and water retention characteristics.

Initially measurements of the convective coefficient were carried out in wind tunnels, the results of which are still used by the CIBS guides. These tests were carried out on flat homogeneous surfaces and the main variables were surface roughness and wind speed. More recent wind tunnel tests (Sturrock, 1971) on cubes have shown the effect of surface length, wind direction, velocity profile and homogeneity of the surface to be important characteristics in influencing heat loss coefficients.

It was found that the convection coefficients on the most exposed surfaces were twice as much as those on the least exposed surfaces. Field measurements (Sturrock, 1971) also showed that convection coefficients varied by up to 30% from values given in the CIBS guides, mainly due to the influence of the form of the building and the configuration of the surroundings.

Convective heat transfer is generally greater than longwave heat loss. Nicol's (1977) work on the energy balance of

windows showed that the relative magnitudes of longwave radiation and convection heat losses varied with wind speed. At low wind speed ($0-0.5\text{ms}^{-1}$) convective heat losses have a similar magnitude to longwave radiative losses, but as wind speeds of around 4ms^{-1} the ratio of convective to radiative heat losses is around 5:1.

5.4.4 Heat loss by Air Infiltration

Not only is the window the most sensitive building element in terms of convective and radiative heat loss but also in terms of air infiltration. To a certain extent the limitations and assumptions made in calculating the long-wave radiative component are acceptable as this mode of heat loss is fairly minor compared with the convective mode or heat loss by air infiltration. Heat loss by air infiltration is typically between 30-75% of the total heat loss in buildings (Arens and Williams, 1977). Therefore, for accurate modelling of heat losses the infiltration component is probably the most important. However, of all the components of heat loss, it is the least well defined and most models that predict infiltration losses only consider the interaction between buildings and climate in a token manner.

Air infiltration is essentially caused by the wind, which affects the air pressure distribution on the surface of a building, and the difference between external and internal air temperature.



Models that predict the quantity of infiltration use meteorological data based on wind speed and air temperature. However, the aerodynamics of a building is unaccounted for both in terms of the relation of the building to its surroundings and the effects of surface features. Both of these factors have been shown to be highly significant in altering the air pressure distribution (Arens and Williams, 1977).

A further factor that is not accounted for is the influence of occupant action on the building, both in terms of altering the building envelope (eg. opening windows) or altering the internal layout (eg. internal doors). For example ventilation rates in houses vary, at low wind-speeds, by over 100% depending on whether they are occupied or not (Arens and Williams, 1977).

5.5 Building Type and Climatic Data

From section 5.4 it can be seen that for an accurate description of the climatic stimuli on a building certain geometrical and physical characteristics of the building must be known. For existing buildings or those where the design is finalised such data could be made available but the data for aiding in the generation of a design must remain inaccurate as it cannot assume the finalised built form.

Certain building types are more sensitive than others to climatic elements depending on characteristics such as:

orientation, shape, texture, proportion of glazing and internal layout. For example, highly glazed buildings are sensitive to wind velocity, solar radiation and long-wave radiation whereas buildings of very low percentage glazing and relying on either mechanical ventilation or air-conditioning are sensitive to air temperature.

There is still a limit to the accuracy of describing climatic stimuli even if the climatic sensitive characteristics of the building are known. Occupant interaction with the building's control mechanisms will alter the building's sensitivity. For example, the opening of a window makes a building more sensitive to air temperature and wind velocity while closing curtains in cold weather will make a building less sensitive to long-wave radiation.

The climatic stimuli are also sensitive to the heating system within a building since this will determine, to an extent, the relative magnitudes of the modes of heat loss. Granum et al (1979) have shown that the energy balance at a window depends on the type and positioning of heater unit as well as the type of glazing. Where radiators are located beneath windows the convection coefficient is larger than is normally accounted for due to air movement on the inside surfaces of the window. With forced convection heating systems the error increases and it was shown that the convection coefficient could be twice as much as the currently assumed values, thereby increasing the 'U' value of single glazing from 5.6 to 6.9 W/m².°C.

5.6 Climatic Data for Daylighting

Climatic data for daylighting is considered separately in this chapter as, although the thermal and visual functions of a window cannot be separated, the climatic elements concerned with heat exchange and daylight can be separated. The purpose of this section is to show the limitations of the conventional 'overcast' description of the distribution of daylight in predicting energy consumption. In this respect there is a strong relationship between the format of all climatic data where energy conservation is concerned as the conventional format describes "worst conditions" which can lead to overdesigning. The format required for predicting energy consumption requires a dynamic description of the actual climate.

An example of the use of the 'overcast sky' model (Moon and Spencer 1942) to predict dynamic environmental performance is the Cambridge environmental model (Hawkes, 1976a). This model calculates the daylight factor at a point in a room using the CIE overcast sky model. It then converts the daylight factors into measures of absolute internal illuminance using data for the availability of daylight. If the internal illuminance exceeds a given value then it is assumed that the lights are switched off. This is erroneous as the 'overcast sky' model is concerned with only the worst conditions whereas the data for availability of daylight is concerned with all conditions and the two should not be combined to produce a measure of

internal illuminance. Furthermore, the 'overcast sky' model does not account for the directional characteristics of lighting from the sun.

For the sizing of windows in buildings where daylighting is predominant, criteria that describes the worst conditions is acceptable. However, if daylighting is to be used efficiently then there is a need for a balance between artificial lighting and daylighting. The optimum balance is dependent upon the orientation of fenestration, time of day and cloud conditions. All of which should be accounted for if energy consumption is to be accurately predicted.

5.7 Summary

The conventional data for describing the external climate is concerned with 'worst conditions' (eg. design temperatures or overcast skies). These descriptions are of use in plant or window sizing but cannot be employed in measuring the dynamic performance of buildings. The greatest potential for energy conservation is likely to occur in average conditions and therefore data of worst conditions will be unrepresentative.

Accurate descriptions of those elements of the climate that interact with buildings are dependent on the physical and geometrical properties of the buildings. Therefore, data for aiding in the generation of a design is inaccurate as it cannot account for building/climate interaction.

The design must be known before the data can be accurately described.

Different building types are sensitive to different climatic elements. This sensitivity can be further altered by the action of occupants on control mechanisms. This limits, to an extent, the accuracy of data even for building designs that are known.

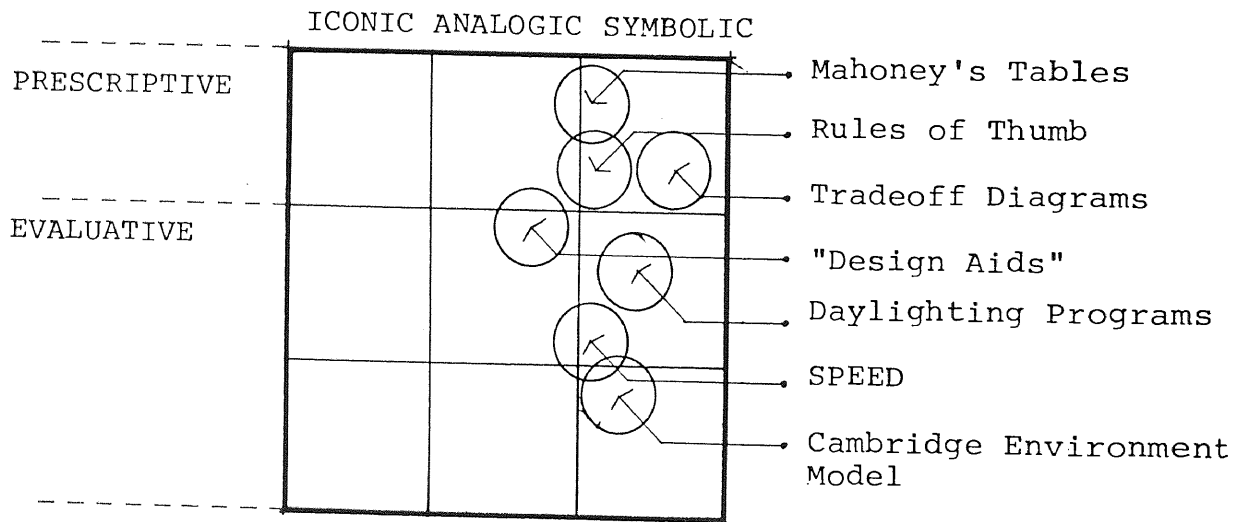

Figure 6.1.1. Typical Models Within Classification Matrix

use and accuracy. For example, prescriptive models have traded accuracy for greater convenience whereas research tools have traded convenience for accuracy as they are, in general, not intended for use by the designer 'over the drawing board'. The accuracy vs compatibility argument (section 1.1) is therefore taken into account and the analysis will vary depending on the intended use of a model.

6.2 Prescriptive Models

Prescriptive models vary from simple rules of thumb that limit for example the area of windows or the depth of rooms to complex computer programmes that can offer a range of alternative solutions to specified requirements of the internal environment. The following part of this section is a review of three types of prescriptive models that differ in their complexity:

- a some common rules of thumb,
- b a set of tables which diagnose climatic data and generate performance specifications,
- c a computerised model that optimises and prescribes properties of a building's fabric for given data of the internal environment.

a Rules of thumb:

Croghan and Hawkes (1969), in a survey of the type of daylighting prediction techniques used during design, found that 73.5% of practising designers employed simple

rules of thumb in order to size windows. At that particular time the rules of thumb were based on legislative requirements that the minimum window area should be one-tenth of the floor area of a room. A rule of thumb using a similar index exists for buildings based on the principles of Integrated Environmental Design where the recommended window area is between 15-20% of the external wall area (Hardy and O'Sullivan, 1967). The use of percentage glazing as a rule of thumb has been renewed with the 1979 Building Regulations part FF where a maximum percentage glazing is specified depending of the purpose of a given building. Interestingly the regulations relate closely to Florence Nightingale's "Notes on Hospitals" (1859) where it was recommended that the window area should be one-third of the wall area.

Not only has the window area been the subject of rules of thumb but also room depth. Hardy (1966) has recommended that the maximum depth of a room with bilateral daylighting should be 14m which may be increased to 22.5m if Permanent Supplementary Artificial Lighting of the Interior (P.S.A.L.I.) is employed or 27m with Permanent Artificial Lighting (P.A.L.). A Study Group appointed by H.M. Treasury (1947) recommended that for daylight offices the maximum depth should be 1.75 times the room height for unilaterally lit rooms and 4 times the height for bilaterally lit rooms.

The room depth and window area are the basic rules of thumb for early design decisions as they comprise the two modes of passive environmental control: variety reduction (section 3.2) by mass and distance. They are deterministic as they have a bias to particular modes of environmental control. For example, twenty percent glazing and room depth over 15m imply a building type similar to those based on the principles of Integrated Environmental Design. However, trends in environmental control mean that such rules of thumb must be continually updated in order to reflect the bias in environmental control of the time.

b Mahoney's tables:

A more complex and sophisticated model than the rules of thumb is Mahoney's tables (see Koenigsberger et al, 1973) which diagnose raw climatic data and transcribe these to thermal indices. These indices are then employed to prescribe performance specifications which include variables such as building layout, spacing and orientation.

They also include the size, protection and positioning of openings and the mass of the structure. However, the tables are restricted firstly because they are only for housing and secondly because the climatic indices are crude and can only discriminate between macroclimate changes. For example, performance specifications derived from Mahoney's tables for housing in all parts of the U.K. would be identical. The tables are therefore essentially normative and it could be argued that the

diagnosis of the climate and performance specifications could be done descriptively equally well as numerically.

c "Tradeoff Diagrams"

An example of an even more complex prescriptive model is the Tradeoff Diagrams (Radford and Gero, 1980). They are intended to aid designers optimise the compromise between the functions of the building in terms of environmental control. It was developed in reaction to evaluative models where the variables of form and fabric of a building are held constant and their effects on environmental performance evaluated by a process of iteration. The Tradeoff Diagrams reverse this process of trial ^{and} error by offering a range of solutions for a given environmental performance, the optimum solutions are then located in such a way that improved levels of one environment (eg: daylight factor) are obtained at minimum disadvantage to another aspect of environment (eg: peak summertime temperature).

The Tradeoff Diagrams are open to almost all the criticisms outlined in section 2 and section 6.3. Firstly, they have a bias to only the most rigorous models as the environmental performance specifications are related to minimum Daylight Factors, peak summertime temperatures, minimum wintertime temperatures and noise levels. Secondly, it is implicit in the model that these criteria are adequate for the formation of an optimum solution. Thirdly, the optimum solution is restricted by the

limitations of constructional variables and the combinations and composition that the computer program will allow. The tradeoff does not identify all the design options as the models are concerned essentially with rooms of which the window area, shading and type of glazing are the main variables. The environmental performance of a building depends on more than just an analysis of a window in relation to a room but also on the layout and orientation of rooms. Certain building types have inherent environmental consequences for which tradeoff diagrams will only be fine tuners and not offer an early design solution. For example, Tradeoff Diagrams will not aid in the generation of an overall building type (e.g. courtyard or pavilion type) but may attempt to optimise the window areas. Thus they may be making the best of a bad design and not aiding in its formulation. Furthermore, the amount and detail of information required to prescribe a solution (e.g. type of glass, 'U' values and wall thickness) are more than a designer may be expected to know at the early design stages, when this type of model is intended to be used.

Of the three types of prescriptive model discussed above, all can be criticised for being deterministic. Each model has a certain bias to a certain form of construction or mode of environmental control. Mahoney's tables are too general and normative and the possible solutions could be equally well described by stereotype buildings for particular climates. Tradeoff diagrams also offer a limited range of solutions but this is because

of the bias in limiting the vast range of possible solutions. Rules of thumb may also be criticised for being deterministic, however, their simplicity of use during the early stages of design renders them more powerful design tools than computerised models.

6.3 Evaluative models as design aids

The essential difference between prescriptive models and evaluative models is that the former aid in the generation of a design solution whereas the latter evaluate a given solution. Evaluative models can be categorised into design aids and research tools. The difference being the degree of sophistication of the models, and the information obtained from them. The former are less sophisticated as they require less information of the description of the properties of climate and building so that they are more easily manipulated by designers.

Three evaluative design aids will be discussed in a similar manner to section 6.2.

- a a graphical design aid intended for the early stages of design,
- b a computerised model also intended to aid early design decisions,
- c computerised models for daylighting design. The latter differs from the first two as it considers only one aspect of the environment.

a "Design Aids"

"Design Aids" (Milbank and Petherbridge, 1974) are graphical analogues of the environmental performance of rooms in buildings for a specified building fabric, window area and solar protection. For a given ratio of area of glass: area of floor, window type, internal wall reflectances and area of openable window the peak summertime temperature, ventilation rate and minimum daylight factor can be assessed. It is assumed that these values will aid the designer to decide on the necessity of the continuous use of artificial lighting and air conditioning. The necessary assumptions taken in terms of active control by occupants and variations in weather conditions are accounted for by a measure of "design risk", defined as a measure of "accuracy of prediction, the vagaries of the weather and the behaviour of the occupants".

Although 'Design Aids' are the reverse of prescriptive models, as they are intended to predict environmental conditions, they can nevertheless be criticised on the similar grounds. They are limited to the types of design they can analyse just as the prescriptive models offer a limited range of solutions. The design aids are further separated into aids for schools and aids for offices. Each building type has 20 thermal design aids, depending on the type of glass and solar protection, as well as ventilation and daylight design aids.

The amount of information required in order to use the design aids is more than can be expected at the early stages of design, a reasonably detailed solution being required to calculate the summertime temperatures. The use of the ratio of glass area: floor area could lead to large inaccuracies, particularly in predicting levels of daylighting, as it makes gross assumptions of room depth. However, the concept of 'design risk' has much in its favour as this can iron out both theoretical inaccuracies and the influence of occupants on environmental control so that the designer can see some of the more disastrous consequences of early design decisions.

b "Speed"

A more complex evaluative design aid is the computer program SPEED (Baxter, 1978). This is very similar to 'Design Aids' but as it is computerised it contains more sophisticated data and more variables. Its purpose is also similar: to identify, at the early stages of design, the extent of the use of supplementary energy, in particular to identify whether air conditioning or permanent artificial lighting is required. It also has a subroutine for calculating internal heat gains and the total annual energy consumption. As 'Design Aids' and 'SPEED' have similar objectives but different levels of sophistication they can be compared on the basis of the compromise of accuracy and convenience. 'SPEED' may be slightly more accurate due to the improved data and number of variables but is more cumbersome to use particularly at the early design stages.

To the designer a graphical analogue, although limited in the number of variables it can contain, is a far easier tool to use as one can interpolate and extrapolate by eye. This combined with a measure of 'design risk' which allows the designer to visualise if the inaccuracies may be too great, make the 'Design Aids' a far more useful tool at the early stages of design. The advantage of SPEED over 'Design Aids' is in the latter stages of design when the 'fine-tuning' to the building envelope occurs.

c Computer programs of daylighting

A further example of evaluative design aids are some computer programs intended for predicting the daylight factors in rooms. The Design Office Consortium (1978) published a comparative study of various programs for predicting daylight factors in terms of their ease of use, modelling capabilities and other factors. All the methods were based on the same theory, the main difference between them being their format and the number of variables involved. The purpose of the analysis in this dissertation is not to highlight the differences between the methods but the shortcomings and advantages of these methods as a whole.

All the methods are 'point-by-point' techniques and involve an input of the room dimensions and reflectances, the window dimensions and transmittance and external obstructions. From this data the programs print out the daylight factors in a grid on the room.

Some of the programs do not account for Maintenance Factors, ground reflectance or external obstruction however, a more important shortcoming is in the application of such results in aiding design. Firstly, these programs, and indeed all 'point-by-point' methods, may be criticised for not aiding in the generation of a design as they essentially check a design. Particularly as the amount of data required by the programs would only be known at the latter stages of design when it is unlikely to be altered. Secondly a grid of daylight factors in itself is of little use to the designer in deciding whether the daylighting conditions are acceptable, except in the extreme cases of inadequate or unnecessary amounts of daylighting.

A further point is that the daylight factor at a point on a working plane is not necessarily representative of the adequacy of daylight within the room (see section 4.3.4). A daylight factor is not a measure of the absolute illumination but a measure of the geometric properties of a window in relation to a point in a room added to an index of the reflectance of the room. Furthermore, a measure of the adequacy of illumination in a room must be related to the relative values of illumination within the room as well ^{as} absolute values. For example, in the appraisal of daylighting within classrooms (Building Performance Research Unit, 1972), the rooms with the highest minimum daylight factor also had the highest use of artificial lighting. This could be due to the positioning and type of switch controls for the artificial lighting but as all classrooms were nearly identical in this respect the increased use of

artificial lighting may be accounted for by the differences in diversity of illumination within the classrooms.

6.4 Research Tools

Research tools are essentially an extension of evaluative models being more sophisticated and able to employ more detailed and dynamic data. There is no distinct boundary between evaluative models and research tools, the main difference being that evaluative models are intended to be compatible with the design process whereas research tools are not necessarily intended for use during design. A further difference is that the output of research tools may not necessarily be in terms of environmental conditions but in terms of cost-effectiveness or energy consumption. For example, although research tools cannot be criticised for their compatibility with the design process their data and structure can be criticised in depth as there is no need to trade accuracy for convenience. Research tools are therefore generally computerised, require detailed input data and allow for limited interaction between aspects of the physical environment.

One such research tool that displays these characteristics is the Cambridge Environmental Model (Hawkes, 1976). Its purpose is to relate aspects of physical form to environmental requirements, allowing the consequences of decisions made in any one aspect to be observed in other aspects so that the environmental performance of different

building types can be compared on a like basis. The main components of the physical environment that are measured are daylight factors, peak summer temperatures and winter heat losses.

An example of the way in which this research tool has been used is in the prediction of the environmental performance of a courtyard-type office building (Hawkes et al, 1978).

One of the shortcomings of the Cambridge model is in calculating the energy consumed by lighting. The calculation is based on converting daylight factors to levels of absolute illuminance (section 5.6) and thence calculating the duration of time for which the levels of illuminance are exceeded. The first assumption is that artificial lighting will be switched when the illuminance is below a certain level at a particular point on the working plane. The second assumption is that the sky luminance distribution does not alter with varying levels of external horizontal illuminance.

A further shortcoming is in the calculation of the peak summertime temperatures in the glazed courtyards. The temperatures, calculated by the 'admittance method' were in the region of 25°C. However, the 'admittance method' was not intended for calculating the temperature of large spaces but "to develop design recommendations for avoiding over-heating in offices in multi-storey blocks". (Loudon 1980), (see section 2.3).

Both the calculation of the peak summertime temperature and the annual energy consumption do not account for any occupant interaction in the control system. Steady state heat loss calculations may be used for comparing the passive means of environmental control of buildings but will not give accurate results for building types that include significant levels of active control.

6.5 Prescriptive vs Evaluative models

In general prescriptive models offer a more logical approach to a design solution but are limited and deterministic in the range of alternatives they can generate. A similar argument applies to evaluative models as their bias to a particular mode of environmental control means that they are limited to the range of building types they can evaluate.

With the exception of Mahoney's tables neither the prescriptive nor evaluative models consider buildings as a whole, in terms of spatial distribution of mass and fenestration, but generally consider only individual rooms of which the window is given most variables. The sizing of windows and decisions concerning the type of glazing are only the fine-tuning of environmental design and may only alter its performance slightly if the overall design is inherently poor.

One approach is to combine prescriptive and evaluative models as the former models may offer a reasonably good

starting solution which could then be improved by the 'fine-tuning' of the evaluative model. However, caution must be taken not to fall into the trap of the Oedipean effect. If the prescriptive model is based on the same theory and data as the evaluative model the prediction of the environmental performance may be a self fulfilled prophecy.

6.6 Summary

The purpose of this chapter is to integrate the conclusions of previous chapters by discussing the limitations of some typical models. The conclusions are that conventional environmental models are both inaccurate in their representation and incompatible with design.

The essential causes of inaccuracy in models are:

- a the limited number of variables in describing the data of both comfort and the external climate,
- b the variables do not fully represent climate or comfort,
- c many models have inherent assumptions of either building type or mode of environmental control,
- d certain models do not account for the interaction between a building and the external climate,
- e most models do not account for the feedback by occupants on the control mechanisms of the building.

The essential causes of the incompatibility of models with the generative stages of design are:

- a models consider only parts of buildings
- b data needed to manipulate models requires that a design is already generated,
- c certain models can only be applied to certain building types,
- d models have a bias to quantifiable criteria.

The implications of these limitations are that conventional evaluative models are only likely to provide a crude prediction of environmental performance. Furthermore, these measures will not aid in the strategic stages of design and hence are only likely to be 'fine-tuners' to designs that may be inherently bad in terms of environmental control.

In section 1.3 it was noted that trends in research are towards improving the data of models. From the above conclusions it can be seen that improvements in data have only a small potential in improving models. Since the overall accuracy of a model is as good as its least accurate component it is unlikely that research into improving data alone will improve the overall accuracy of models. Even if research was to produce models with the potential of a high degree of accuracy, they are unlikely to influence strategic design decisions as they are incompatible with the generative stages of design.

CHAPTER 7

THEORIES OF THE DESIGN PROCESS AND THE ROLE OF MODELS

7.1 Introduction

It was noted in section 1.2 that the conventional description of the design process, until recently, is that of an iterative process of analysis-synthesis-evaluation. This assumes that a design solution is generated from the decomposition of a design problem. The role of environmental models within this context is assumed to be at the evaluative phase where their function is to refine the evolving design.

Alternative theories of the design process have suggested that a design can only be generated from a preconceived solution since the decomposition of the design problem must be carried out within a given context. The role of environmental models in relation to this theory should be to influence the preconceived solution.

This chapter analyses the role of environmental models in design with reference to these theories of the cognitive processes of design. It is argued that if models are to aid in improving the environmental performance of designs

it must come from a knowledge of the environmental consequences of the preconceived design solution.

7.2 Strategy vs. Tactics

The importance of employing models at the early stages of design has been discussed by Page (1976) who described the design process as having two stages. The first stage being the generation of form and the second stage involving detailed work. Major climatological decisions are made at the first stage and any action to improve the climatic environment at the second stage is tactical rather than strategic.

The most potentially influential role of models in the design process is therefore as, 'form generators' at the strategic stages rather than 'fine-tuners' at the tactical stages. The paradox of conventional models that describe the environmental performance of buildings is that they become more accurate with the increased data available at the later stages of design but their influence in improving environmental performance becomes less. Decisions with major environmental consequences are made at the 'generative' stages of design and most evaluative models cannot be employed until after these decisions are made.

This can be described in terms of the P.D.I. model (March, 1976) (section 1.2) where Production is analogous to strategy

and deduction to tactics. Employing the definitions of Productive and Deductive reasoning, the inference of a case from a rule (composition) has many inherent environmental consequences. The application of a general rule to the case (decomposition) only has the potential of being a 'fine-tuner' to these consequences. Therefore a knowledge of environmental performance during the composition of design can be seen as strategic whereas a knowledge of environmental performance after the decomposition of a design is tactical.

7.3 The Conventional Role of Environmental Models in Design

Within the terms of reference of a design theory that assumes the composition of a design solution to be obtained by the decomposition of a design problem, models can be seen to directly influence the generation of form. The implications of this 'form follows function' theory, in terms of environmental modelling, is that if the function can be described then environmental models will determine form.

An example of this is Broadbent's (1969) 'Environmental Design Process' where he suggests that a 'permissible building envelope' can be built by plotting an 'environmental matrix' consisting of the environmental stimuli around the proposed building. Likewise Page (1976) suggested that the form of a building could be determined by the climatic stimuli around it, and proposed

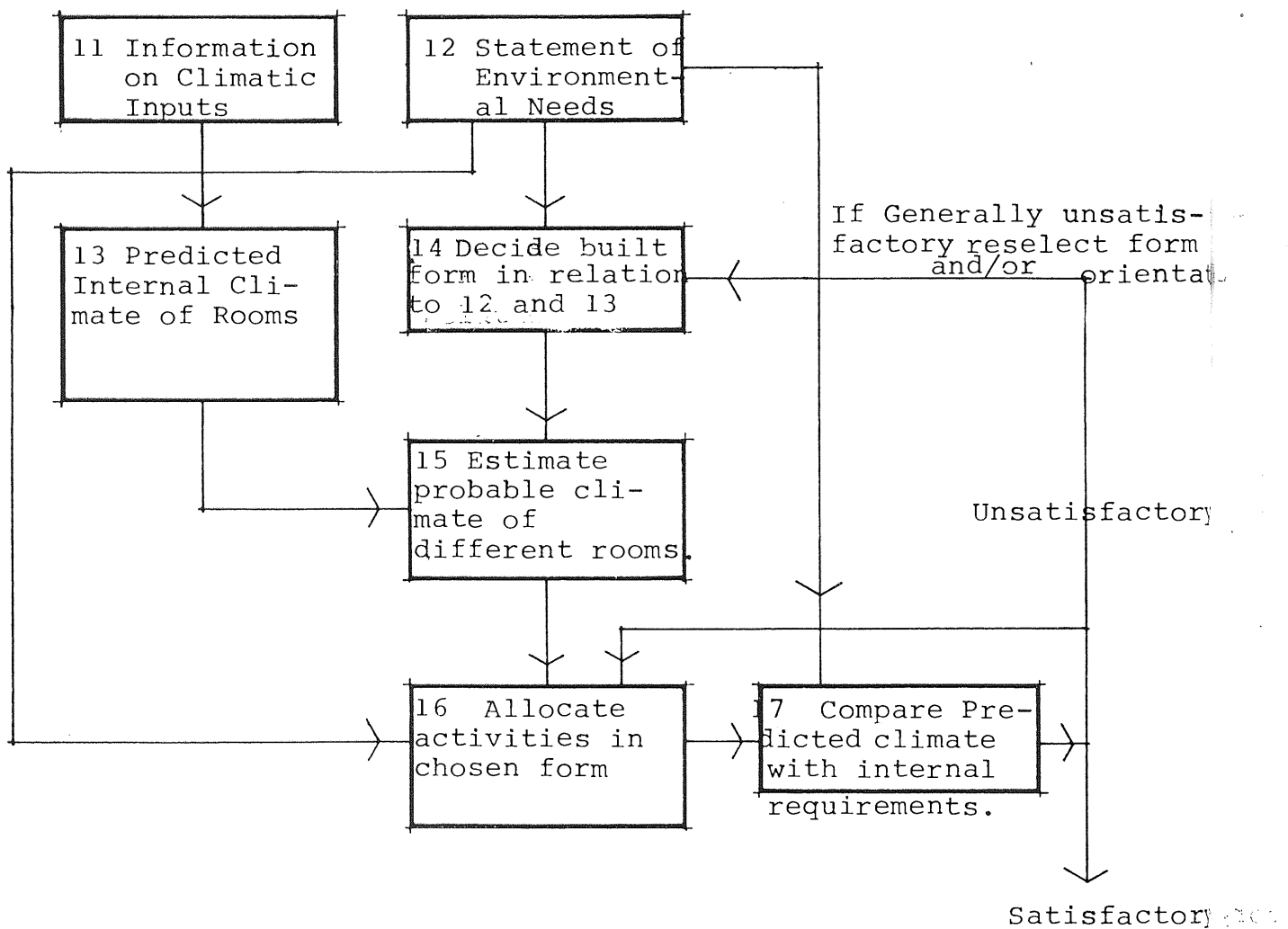

Figure 7.3 An Iterative Process of Generating Built Form
 (After Page, 1976).

that this can be done in a systematic way. Figure 7.3 demonstrates this systematic method by a flow diagram to which an input of external climatic data (box 11) and data of occupant response (box 12) can be manipulated to formulate a design in terms of form and orientation (box 14). The design is then evaluated in terms of its environmental performance and rejected or accepted depending on results. "Thus a hypothesis concerning form is formulated which uses data drawn from boxes 12 and 13 to match climate with needs. A check can then be made to see if the needs of activities located in different parts of the preliminary design are correctly matched to the preliminary predictions of internal climate. If the answer is unsatisfactory, a new design must be chosen". (Page, 1976)

This iterative type of procedure is common to all systematic methods of the design process based on decision theory. The theory being that by a sequence of decisions the form can be moulded from the function by a process of iteration of analysis, synthesis and evaluation. Such a process is better known as 'Design Method' and is carried out systematically: analysis relates design requirements to performance specifications, synthesis is the formulation of a solution and evaluation is the testing of the solution in terms of the performance specifications. Relating this to figure 7.3., boxes 11 and 12 are the analytical stages, box 14 is the stage of synthesis and box 17 is the evaluative stage.

7.4 Theories of the Design Process

7.4.1 Design Method

Design method has been described in many different ways (e.g. Alexander (1964), Archer (1963), Jones (1965)) but all are variations on the theme described in section 7.3 and although semantics differ almost all the proposed methods are composed of analytical, synthetic and evaluative stages which are intended to formulate a design by iteration.

The role of environmental models in this process is seen to be at the evaluative stage where the synthesised design can be evaluated in terms of the performance requirements specified at the analytical stage. Design solutions are therefore generated and evolve through the cyclic application of the stages. Hence 'evaluation' is seen to directly influence 'synthesis' the form generating phase. If 'design method' is an accurate description of the cognitive processes that generate form then evaluative environmental models do have a role in aiding form generation. However 'design method' has been criticised as being an unrepresentative description of the design process because the stage of synthesising is seen to be a 'black box' (Archer, 1969) and cannot be conducted systematically or objectively. That is to say that design method cannot account for the source of a solution. If the generative phase of design cannot be carried out objectively then there is no place for evaluative models in aiding form generation.

Evaluative models can only be 'fine-tuners' in improving the environmental performance of a design after the main decisions have already been made.

It was because the 'black box' or 'creative leap' in the stage of synthesis could not be accounted for that 'design method' was no longer considered as a reasonable theory for the design process (eg: Colquhoun, 1969).

One criticism of 'design method', in particular the cyclic procedure is the concept of 'wicked problems' (Rittel, 1972). A 'wicked problem', of which the design process is one, is described as a problem that cannot be defined until the solution has been found.

"Information needed to understand the problem depends on one's idea for solving it. That is to say: in order to describe a wicked problem in sufficient detail one has to develop an exhaustive inventory of all conceivable solutions ahead of time. Problem understanding and problem resolution are concomitant to each other. Therefore, in order to anticipate all questions requires knowledge of all conceivable solutions." (Rittel, 1972). The concept of 'wicked-problems' not only negates 'design methods' as a theory of the design process but also describes the basis of two other theories of the cognitive process of the generation of form: the linguistic and evolutionary analogies (Note 1).

7.4.2 Linguistic and Evolutionary Analogies

Since 'design method' there have been two explanations of the generative phase of the design process: the 'linguistic' and 'evolutionary' analogies. The 'Linguistic' analogy is based on Chomsky's (1971) 'transformational grammar' theory and relates design to language (as they both simultaneously interpret and construct reality). Chomsky suggested that the generation of sentences (analogous to the generation of form) depends on both 'deep structures' that map meaning to semantics and 'surface structures' that map semantics to verbal production. The analogy in design is that 'deep-structures' map the problem statement to a general solution, the 'surface-structure' then maps the general solution to a specific solution (Hillier and Leaman, 1974). 'Deep-structures' are strategic while 'surface structures' are tactical.

"The speaker, like the designer, starts from a prestructure in which the most important entity is abstract structure by which mapping between dissimilar domains may be effected. Without the mapping structure these are virtually useless and only meaningless sounds or arbitrary artefacts could be generated." (Hillier and Leaman, 1974)

The prestructuring therefore acts to interpret the problem for a designer and also acts as a solution field. The evolutionary analogy is very similar and suggests that a design, like an organism, grows from a seminal idea (genotype) which interacts with its environment as it grows and in so doing becomes more complex (phenotype). The genotype

has the genetic structure of the organism while the phenotype contains both the characteristics transmitted by the genes as well as environmentally obtained characteristics. The important similarity between these two analogies of the design process is that they both account for the source of the solution to a design since they both suggest that in order to understand a problem one must already have a solution. The 'genotype' or 'prestructure' contains a generalised solution by which a problem can be understood. This point has been paraphrased by Steadman (1979):

"There could be no way in which the form would come out of the context; in which the design problem would, so to speak, produce its own solution. It would be necessary to bring some pre-conceived pre-established design to the problem in hand in order that any process of testing and evaluating its anticipated performance could begin in the first place. In the biological analogy this would correspond to the way in which selection, is at any point always acting on the inherited 'design', which has been passed down from the whole of the species' evolutionary history."

7.5 Building Typologies

Hawkes (1976) has suggested that the architectural equivalent to a 'genotype' or 'deep-structure' is a 'stereotype' which is defined as "a generally held notion about the nature of a good solution to any recurrent building design problem and that it is this notion which frequently inspires the initial design hypothesis".

Broadbent (1979) has described this mode of designing as 'typologic' design, in which the members of a particular culture share a fixed mental image of what the design should be like.

Hawkes (1976) has demonstrated how office building typologies have evolved from heavyweight with low percentage glazing to lightweight with high percentage glazing and back to the low percentage glazing of I.E.D. building types. The evolution being influenced by legislation, technical change and social change. However, in discussing how building typologies, in particular the I.E.D. type, are promoted he (Hawkes, 1978) suggested that;

".....although this type was derived by analysis, it has been promoted consciously through its image we are shown designs not offered design aids!"

Clearly the typology that is thought to be a good solution and which initiates the design process contains in it many of the major environmental decisions which have not come about by objective evaluation. Such characteristics as form, room depth and the amount of glazing may well be inherent in the chosen typology and its evolution by evaluative models will be only 'fine-tuning' to a solution that may be inherently bad (Note 2). If the chosen typology is not rejected the design may have to rely on unnecessary supplementary energy in order to provide a habitable environment with the inherent consequences of reduced occupant control and increased energy consumption.

7.6 Summary

During the time that many design aids were being formulated the conventional description of the design process was Design Method. This assumed that a design solution could be generated from the decomposition of a design problem.

Within this frame of reference evaluative environmental models, which are employed in the decomposition process, can be seen to directly influence the generation of form. However Design Method has been criticised as being an inaccurate description of the cognitive processes involved in design as it does not account for the source of a solution.

Alternative theories, in particular the linguistic and evolutionary analogies account for the source of a solution in terms of a 'deep-structure' or 'genotype'. The implications of these theories is that a design problem can only be understood within the context of a preconceived design solution. This solution has inherent in it many strategic environmental consequences, the application of conventional environmental models to the solution being tactical.

An alternative role for environmental models would be to influence the preconceived solution at the strategic stages. This cannot be undertaken by conventional environmental models as they are unable to describe the performance of a building holistically.

The following chapters describe an holistic measure of environmental performance and a method for its application to influencing strategic design decisions.

Notes

- 1 The philosophical analogy has also been used to describe the design process (Hillier et al, 1972). This analogy does not attempt to describe the cognitive processes of design but highlights the difference between the 'conjecture-analysis' vs. 'analysis-synthesis' argument. Analysis-Synthesis is seen to be equivalent to Newtonian philosophy which assumes that scientific laws correspond directly to reality and can be deduced empirically without preconceived ideas of the laws. Conjecture-analysis is equivalent to Kantian philosophy which suggests that scientific laws can only be obtained within the context of preconceptions.

- 2 Canter (1972) cites an example of the design of a children's hospital where formulations of the three dimensional shape of the finished building were in existence before a detailed analysis of the design requirements were made.

THE ENVIRONMENTAL PERFORMANCE OF BUILDING TYPOLOGIES

8.1 Introduction

Building science has concentrated on isolated building elements and the prediction of environmental performance is generally carried out on a 'room-by-room' basis. There exists no method of measuring whether one building type is inherently better than another in terms of environmental design. To describe the environmental performance of a whole building in terms of its parts would not necessarily identify those gross characteristics of form that may make one building type better than another (e.g. pavilion vs. courtyard). Thus there is no way that a building designer can readily identify at the early stages of design a building type whose environmental performance is inherently good. The only option open to the designer being to evaluate parts of a building design by a process of 'trial and error'. Conventional models that predict, for example, peak summertime temperatures, daylight factors and sound reduction characteristics of a building envelope are unlikely to be any use in comparing building designs on an holistic basis.

This chapter changes the emphasis from the critical framework of the previous chapters towards a development of an analytical framework intended to form the basis for identifying building typologies whose environmental performance can be predicted at the early stages of design. A rudimentary measure of environmental performance based on empirical studies is proposed. It is argued that even a crude estimate of environmental performance at the early stages of design is a more rational approach to good environmental design than a more accurate evaluation after the major environmental decisions have been made.

8.2 Design theory and holistic analysis

An assumption in environmental modelling has been that buildings can be holistically described and compared by conventional environmental models. This assumption was based, to an extent, on the description of the design process. The conventional description (design method) being that the composition of a solution is derived from the decomposition of the problem. The implication of this being that holistic evaluation is not required as the performance of a building can be described by the sum of selected measures of its parts.

In terms of the P.D.I. model (section 1.2) the conventional role of environmental models is that of deduction or decomposition. If design is seen as a process of analysis-synthesis then the stages of deduction will produce a solution.

However, this description of design has been criticised (section 7.4.1) on the grounds that it cannot account for the source of a solution and that the only way by which a problem can be decomposed is within the context of a conjectural solution. The implications of this is that the conjectural solution or design hypothesis contains inherent environmental consequences (eg. deep/shallow or pavilion/courtyard). A role for strategic environmental models could therefore be to demonstrate the environmental consequences of building typologies in order to influence the design hypothesis.

In section 2.5 it was noted that one method of obtaining holistic measures of environmental performance of building typologies is by employing research tools. The argument being (section 1.3) that research tools can provide a link between decomposition and composition as one of their characteristics is that, being more complex, they can retain an overview of a building and its systems as a whole.

However, the purpose of the critical analysis of models in previous chapters was to show the limitations of research tools, as well as other models, in describing the environmental control system. Conventional research tools have evolved from more simplistic models and inherited many of their limitations. They do not, therefore, provide any inductive feedback between the decomposition of a design and the composition of a design hypothesis.

Any alternative to research tools in the holistic analysis of the environmental performance of building types requires a different basis for evaluation. In order to overcome the problem of atomism any measures of environmental performance must be less specific and hence more rudimentary. The necessity for being less specific is that holistic measures, by definition, cannot consider the thermal, luminous and acoustic components of the environment or the modes of environmental control in isolation.

However, a rudimentary knowledge of the environmental performance of a preconceived design solution can be argued to have greater advantages than a more detailed description of environmental performance after the strategic environmental decisions have been made.

8.3 An Alternative Measure of Building Performance

An alternative and holistic measure of a building's performance is its sensitivity to environmental modification which can be analysed through a knowledge of a building's energy consumption. In section 4.4 it was argued that a person's ability to modify the environment was a measure of comfort. This ability is dependent upon the availability of control mechanisms (section 3.5.1) (eg. opening windows, switching lights or altering thermostats), and the responsiveness of the building fabric (eg. area of openable windows or thermal inertia). These are in turn dependent

on the characteristics of a given building type and the extent of use of these mechanisms and their efficiency is manifested in energy consumption. The energy consumed as a consequence of these control actions is therefore an approximate measure of the performance of a building and its sensitivity to be modified.

An example of sensitivity is the opening of a window for increased ventilation. In certain building types with large openable areas of windows the environmental conditions are sensitive to control actions since only a small degree of action will cause a large change in the area of opened window. The sensitivity is also dependent on the response of the building fabric, in this case its thermal inertia.

The method by which such a measure may be obtained can be described by the results of a survey carried out on ten schools in Hampshire C.C. (Perkins et al, 1977). The schools were identical in terms of construction, size, plant, plant efficiency, internal temperatures, number of pupils and pattern of use. Any variation in energy consumption could only be attributed to differences in microclimate, orientation and user-response to the control mechanisms. However, no correlation could be found between energy consumption and microclimate or orientation although energy consumption varied by up to 50% between the schools.

Such a variation can almost entirely be attributed to differences in user response and is therefore a measure of

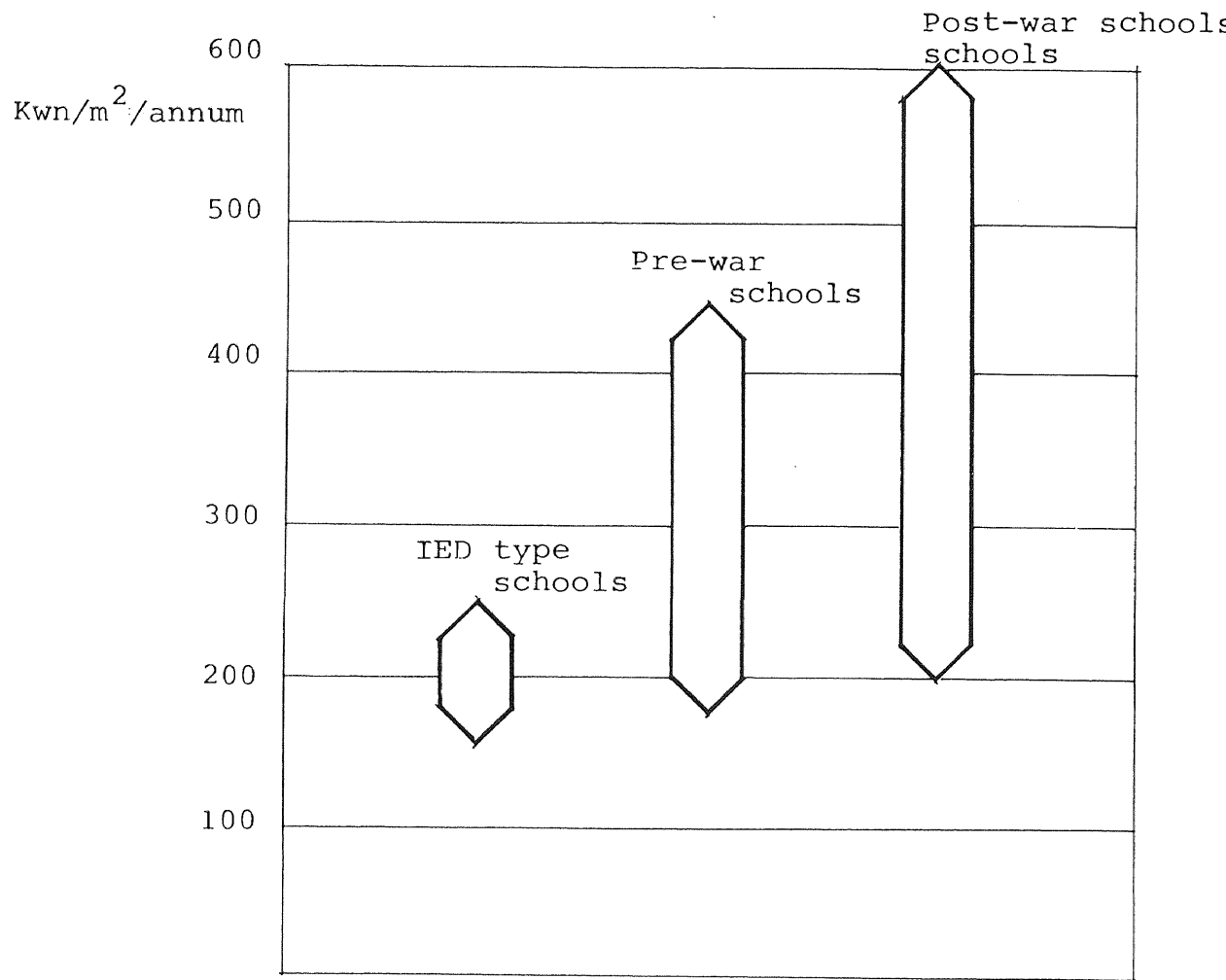

Figure 8.4 Energy Consumption for School Types in Essex C.
 (After Page and Crowe, 1976)

the building-type's sensitivity to environmental modification and cannot be considered as an anomaly of the effect of occupants on buildings.

8.4 Environmental performance inter and intra building-type

The measure of energy consumption intra building-type means little by itself but when considered in conjunction with other building types the comparative variations, as well as mean level of energy consumption, reveal a simple although crude method of ranking building types according to their energy consumption and sensitivity to environmental modification.

A further example to demonstrate this is an energy survey carried out by Essex C.C. (Crowe and Page, 1976) on various school building types. Because of the large sample and impurity of building types, the schools have been categorised by age. The three categories are

- a buildings based on the principles of I.E.D.,
- b pre-war buildings, generally traditional, heavyweight types and
- c post-war buildings, generally lightweight system-built schools (figure 8.4).

Due to the size of the sample, and because the survey was not designed to measure the variation in energy consumption intra building types, the types were not normalised to

account for plant efficiency, pattern of use or number of pupils. Instead an index of energy consumption per unit floor area was used to compare the schools. Although this index is only a rough measure for comparing building types, figure 8.4 nevertheless shows the variation both inter and intra building type. As the sample number of post and pre-war types was the same, the post-war building types show a greater sensitivity to environmental modification, probably due to the lower thermal inertia and larger openable window areas of these types. The compressed variation of the I.E.D. types is due to a combination of a smaller sample and the inability of occupants to environmentally modify such types.

8.5 Energy consumption inter and intra school typologies: field studies

While the first example (section 8.3) has the advantage of having highly controlled variables, the survey is only concerned with one building type. The second example (section 8.4) has the advantage of an inter building-type comparison but many of variables are uncontrolled. To combine the advantages of the two examples a survey was carried out on school types in Birmingham and a sample of three hundred schools was classified into six basic types (figure 8.5.a) (Note 1).

Some of the schools were not included in the sample as they did not conform to any of the types or were not pure

BUILDING TYPES

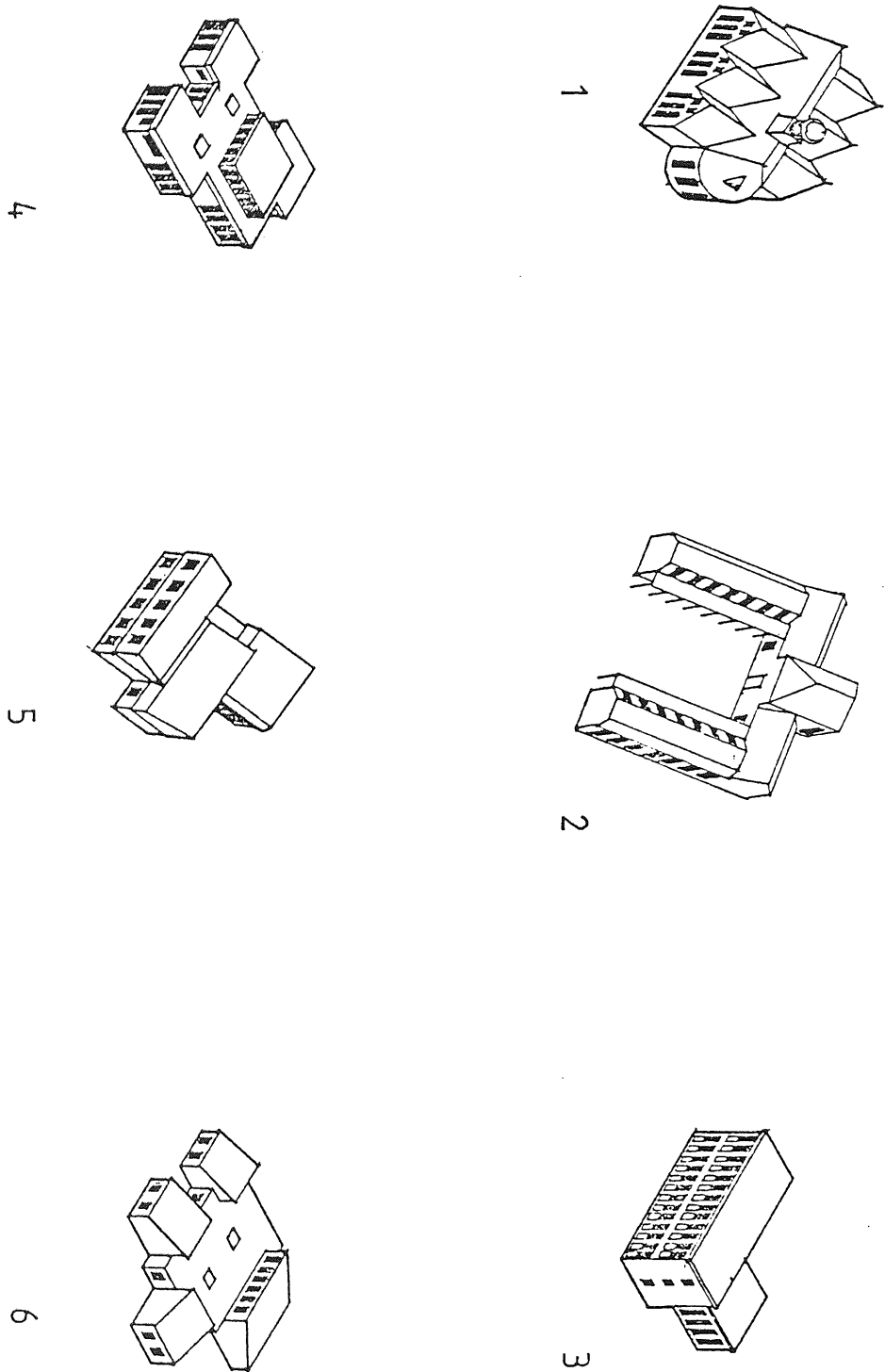

Figure 8.5a School Building Typologies

types, usually because a substantial part of the school had been extended.

Type 1 is a stereotype Victorian School (post 1870) of high thermal inertia. The classrooms are directly off the main hall giving the school a compact plan and fairly low % glazing.

Type 2 is typical of the 1930's cross-ventilated schools. It is of lightweight construction, highly glazed, and its 'finger'-like planning gives it a high perimeter: floor area ratio.

Type 3 is a 1950's corridor plan type school which is highly glazed due to the influence of the 2% Daylight Factor requirements.

Type 4 is a 1960's system built school, similar to many schools built by a schools consortia, with a high % glazing but compact plan.

Type 5 is only typical to Birmingham and was one of the earlier attempts at open-plan schools; alternate classrooms have demountable partitions between them.

Type 6 is also typical only to Birmingham and is essentially an open-plan school of heavyweight construction but with a fairly high proportion of glazing.

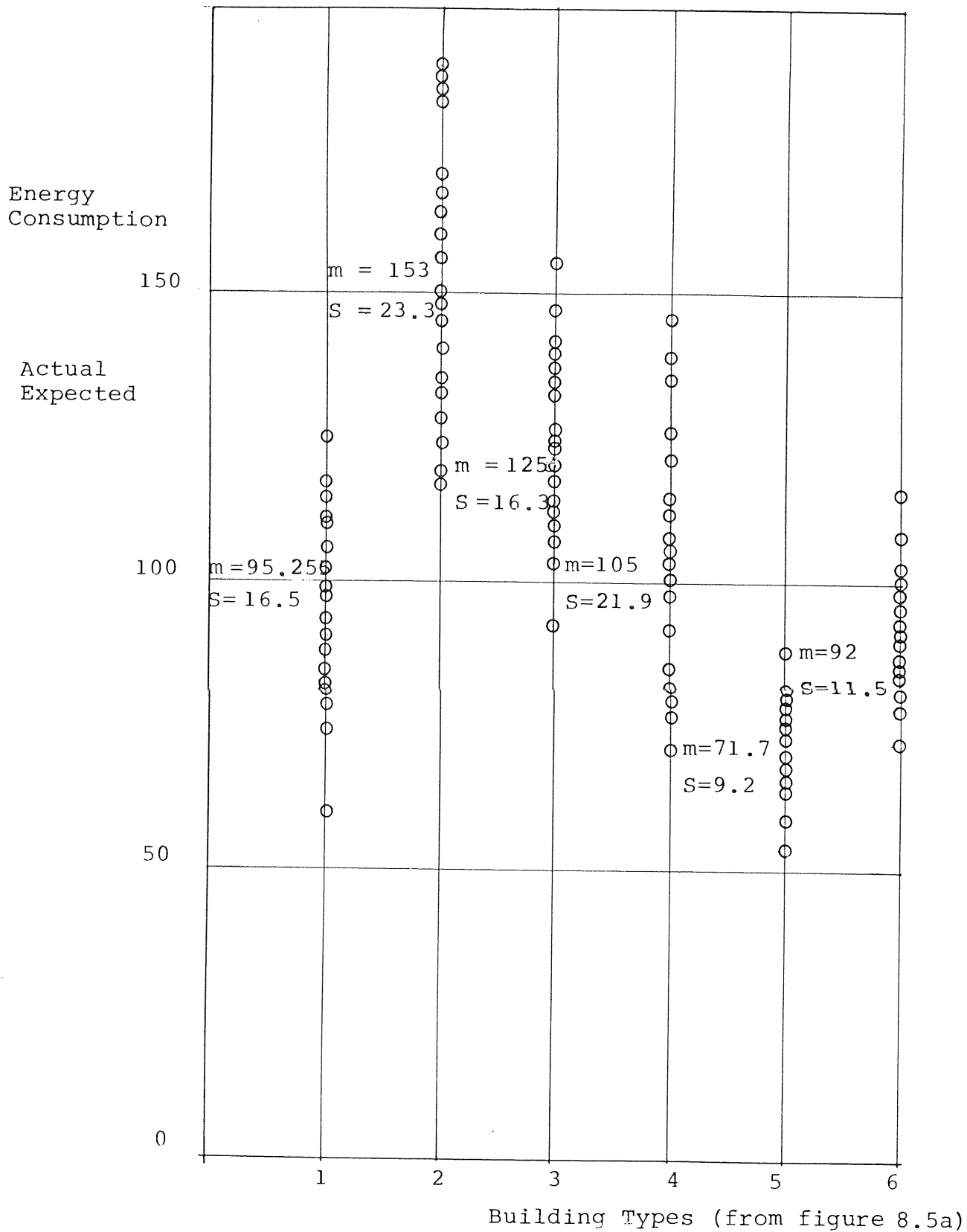

Figure 8.5b Variation in Energy consumption Inter and Intra Building Types

m = mean
s = standard

The expected (note 2) energy consumption of each school type was normalised by taking into account the floor area, type of fuel used, number of pupils, duration and pattern of use, exposure and internal temperatures. The only aspect that was not normalised was the constructional type of each school.

The normalised energy consumption was then compared with the actual energy consumption of the schools. Schools in which the services systems were clearly inefficient were not included in the sample. These schools combined with those of impure types reduced the sample to one-hundred and twelve schools which are evenly divided up between the six typologies.

Figure 8.5.b shows the percentage of actual: normalised energy consumption between the school types. Not only is high energy consumption related to lightweight and highly glazed buildings (types 2,3 & 4), as is to be expected but these types also show the greatest variation in energy consumption.

The energy consumption considered so far is for space heating only. A further measure of environmental performance is energy consumed by electric lighting. Unfortunately the survey on electricity consumption was inconclusive as the school types had mixtures of fluorescent and incandescent lamps, and in many schools electricity was consumed for purposes other than lighting.

8.6 Inter and Intra Building type analysis vs. evaluative studies

The survey and results discussed above can be compared directly with Haigh's (1977) comparative evaluation of classrooms in five school building types.

The classrooms were compared in terms of daylight factors, summer heat gains, ventilation rates and winter heat losses. The measurements were predicted using evaluative environmental models but only winter heat losses were compared with actual measurements. No correlation was found between actual and predicted energy consumption and this was assumed to be the effect of plant efficiency and management policies. However, this may also be due to the fact that occupant interaction with the building fabric was not accounted for in the evaluative models employed. This assumption of the occupants being inactive may also render the other predictions, for example summer heat gains and ventilation rates, inaccurate. Furthermore, since these evaluations are done on a 'room by room' basis the results give the designer little information of which building-type has a better overall environmental performance.

A further criticism of not accounting for occupant interaction applies to those indices intended to compare different buildings on a like basis. For example the volumetric heat loss ('G' value) is a crude index for

comparing the heat loss characteristics of buildings. It is conceivable that two different building types (eg. types 1 & 4 of figure 8.5.a) have identical volumetric heat losses. However this index of heat loss only takes into account the passive modes of environmental control and, depending on the sensitivities of the building to environmental modification by occupants, the actual heat loss characteristics of the occupied buildings may vary considerably (note 3).

The results of the evaluative models can be compared with the results of energy consumption variation intra building-type in terms of their ability to holistically evaluate a building's environmental performance in order to aid in the formulation of future designs. The analysis of energy consumption and its variation intra building-type is only a crude measure, however it has several advantages over evaluative models:

- a by a process of normalisation of factors such as those described in section 8.5 all but the building's passive control and occupant's control actions can be isolated out. This makes it possible to analyse the effect of the form and fabric and its sensitivity to modification of environmental control. Conventional evaluative models can only analyse the passive mode of control.
- b energy consumption and its variance are holistic measures of the performance of building types.

c the variance in energy consumption intra building-type offers a measure of the sensitivity of buildings to environmental modification which is important both in terms of energy conservation and environmental performance.

d these measures, although crude, offer designers an holistic appraisal of built form and fabric which can aid at the early stages of the design process.

8.7 Further research

The rudimentary nature of the variation in energy consumption intra building types as a measure of environmental performance could be substantially improved by further research into other school types as well as buildings of other functions. Hawkes (1976), for instance, has identified some 'stereotype' office designs which could be analysed in a similar method to the school types discussed above.

Further research would require firstly an identification of building types, which requires a knowledge of their historical evolution. Secondly, by choosing a large sample, many of the variables that influence energy consumption which are not affected by building fabric or occupant control action can be controlled or normalised. Thirdly, having isolated out aspects such as pattern of use and plant efficiency the variation in energy consumption inter and intra building types can be analysed and limits of variation identified.

For example, referring to figure 8.5.b a building type of high energy consumption and high variation intra-type (eg. type 2) has both a fabric of poor thermal properties and is very sensitive to fabric alteration by the occupants. At the other end of the scale an I.E.D. building type may have a low energy consumption but the variation intra-type may be too low implying that the occupants cannot resort to altering their environment. From figures 8.5.a and 8.5.b it appears that traditional building types, if thermally upgraded to the same standards as I.E.D. types, would be comparable in terms of energy consumption but at the same time allow for occupants to alter their environments.

8.8 Summary

It has been argued (sections 8.1 and 8.2) that in order to influence the environmental performance of buildings during the strategic stages of design a knowledge, albeit rudimentary, of the performance of the preconceived design solution is required. This cannot be carried out by conventional environmental models since they consider only isolated characteristics of a building and components of the environment.

In section 8.3 it was suggested that the variation in energy consumption inter and intra building types provides a measure of environmental performance that can compare building types on an holistic basis. This measure is derived empirically.

and based on the argument (section 4.4) that the response of occupants to the environmental control system is a measure of comfort. Given a sufficient number of an identical building type where the characteristics affecting energy consumption can be normalised, then the variation in energy consumption is a measure of the sensitivity of the building type to be modified by occupants. This measure may then be employed to promote building types of good environmental performance.

It is suggested that further research on building types may uncover the acceptable upper and lower limits of the variation in energy consumption and offer further holistic measures of environmental performance.

Notes

- 1 The original survey, which was independent of this research, was carried out by the National Industrial Fuel Efficiency Service for the City of Birmingham Education Department. It compared the actual energy consumption with the predicted energy consumption for each school for the purpose of identifying schools that consumed excessive energy. These results were processed further and used by this research in classifying the schools into six types and comparing the variations in energy consumption.

- 2 Expected energy consumption is calculated from the mean of empirical results and adjusted depending on the size and characteristics of occupation.

- 3 A further point is that the variation in energy consumption is a measure of the effect of occupant interaction. Whereas the dynamic modelling of occupant control requires a knowledge of the cause of occupant interaction. While existing measures that predict the threshold of occupant interaction are crude, empirical measures of the effect of occupant interaction can be argued to be more reliable than those that attempt to measure the cause.

CHAPTER 9

THE APPLICATION OF BUILDING TYPOLOGIES IN THE DESIGN PROCESS

9.1 Introduction

The previous chapter described a method by which the environmental performance of building typologies could be analysed. It was argued that the variation in energy consumption inter and intra-building types offers a rudimentary method of holistic analysis and that further research may make such an analysis more sophisticated and reveal further holistic measures of environmental performance.

This chapter is concerned with how building types may be applied to aid in predicting environmental performance at both the early and later stages of design. By classifying building types according to their environmental performance it is possible to observe trends and artificially evolve synthetic types.

9.2 Classification of building typologies

9.2.1 A classification system

While it has been argued (section 6.5) that prescriptive models, of which building typologies are one form, offer a logical approach to a design solution of good environmental performance, the application of building typologies is

fundamentally different to the prescriptive models discussed in section 6.2. The aim of typologies as an aid at the early stages of design is not to systematically optimise, in the same manner as "tradeoff-diagrams" or 'rules-of-thumb', nor to offer a single example (e.g. design assistance by example section 2.2.1) but to show the range of the possible solution field and the environmental consequences of choosing any part of this 'field'.

In order to demonstrate the environmental consequences of a range of typologies, a classification system in the form of a matrix is employed which allows for interpolation between existing types and the identification of types of good environmental performance.

9.2.2 Matrix dimensions

Depending on the purpose of the classification of typologies, the dimensions of a matrix will differ. An approach to identifying the dimensions that describe environmental performance is through the concept of 'variety reduction' (section 3.2). Extending the description of this concept: the building envelope reduces the variety of energy entering by 'smoothing out' the gross repetitive characteristics of the external climate. The building's plant, which includes all forms of supplementary energy (e.g. heating, lighting, cooling and noise generation) further 'smooths out' the variation to retain the internal climate within 'comfort zones'. In terms of the characteristics of a building, variety reduction is therefore achieved by the passive

components of environmental control and any deficiencies in this are supplemented by energy from the plant. The extent of the use of the plant is therefore a measure of the deficiency of the passive mode of control. The components of the passive mode being those characteristics that exclude an occupant from the external climate: mass and distance. Mass is a property of the building fabric and distance, the spatial distribution of mass, a property of form. The form and fabric therefore provide two of the dimensions that can be used to describe a building, from which the environmental performance may be analysed. At the same time 'form and fabric' are the main variables that the designer can manipulate at the early stages of design.

The third dimension is the supplementary energy required to overcome the environmental deficiencies in any combination of form and fabric.

In certain climates the form and fabric of a building will produce an internal climate within the comfort range but without the use of supplementary energy. However in most circumstances, due to climate, economics and building use, supplementary energy is required.

For the purposes of the present description of the dimensions of the matrix, the components and quantification of the indices of form, fabric and supplementary energy are not vital, though form and fabric are the main variables in

SUPPLEMENTARY
ENERGY

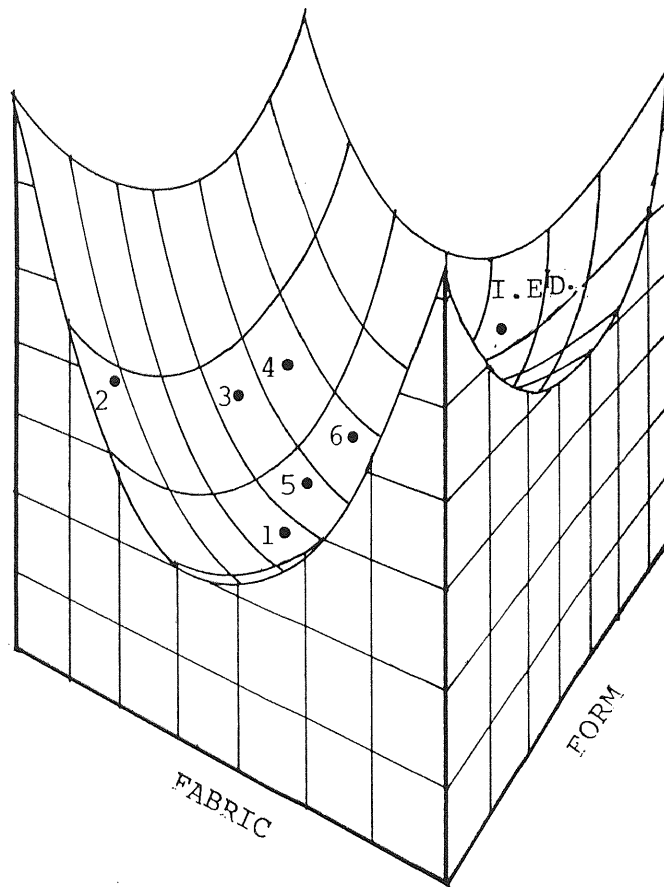

Figure 9.2.2a. Classification Matrix for Building Typologies
(Numbers correspond to school types in figure 8.5a).

many rules-of-thumb. For example form could be described by an index that could include the ratio of wall: floor areas (B.P.R.U., 1972) the surface area: volume ratio and the absolute depth of a room from a window. Fabric could be described by an index of percentage glazing, thermal capacity and thermal transmittance of a building's envelope. While supplementary energy can be described by an index of the variation in energy consumption inter building type. This index could include the energy required for lighting as well as space heating (section 8.5).

Within these three dimensions building types of known environmental performance can be plotted. Figure 9.2.2a is a matrix whose dimensions are form, fabric and supplementary energy. A surface is described within the matrix which gives the values of supplementary energy required for a building type of any given form and fabric and assumes that the level of supplementary energy supplied will retain comfort conditions. This surface is hypothetical as the values of the dimensions cannot be determined at this stage.

The three-dimensional matrix represents the passive mode of environmental ^{control} and its consequences in terms of energy consumption. A further dimension is the extent to which a building can be modified by active control. This dimension would be composed of an index that describes the influence of the active control mechanisms and the responsiveness of the building to the control actions (section 3.5.1). Figure 9.2.2.b is a matrix which illustrates some of the

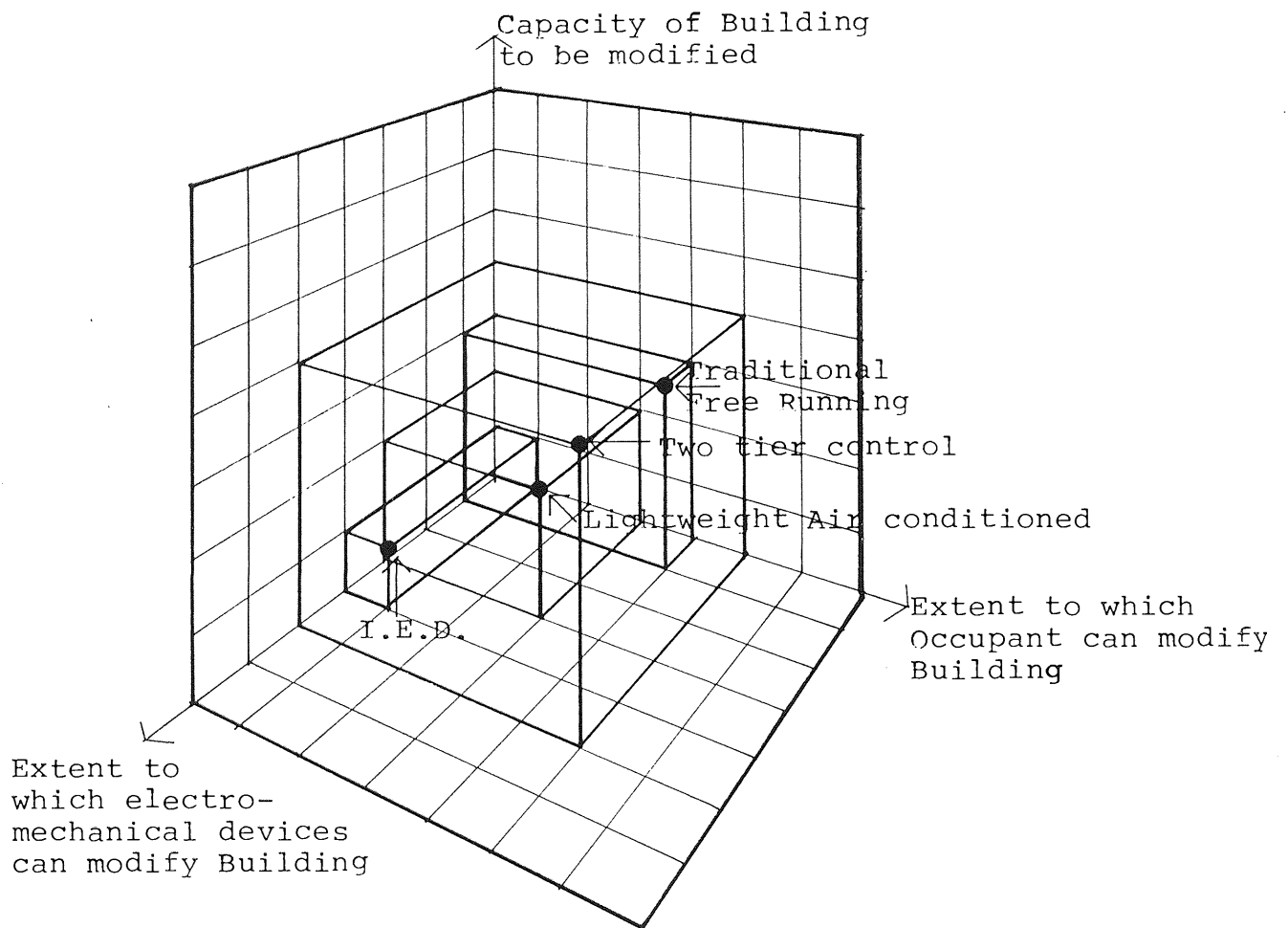

Figure 9.2.2b. Components of Active Environmental Control

components of such an index: the capacity of a building to be modified and the mode of modification whether by electro-mechanical devices or by occupants. Certain building typologies are described within the matrix.

This index of the sensitivity of a building to environmental modification can be crudely quantified by the variance in energy consumption intra building type (section 8.5). This measure can be superimposed on the dimension of supplementary energy on the classification matrix (figure 9.2.2a) in order to describe both the performance of the form and fabric (passive control) and the sensitivity of the building to be environmentally modified (active control and dynamic characteristics of passive control).

Within these four dimensions: form, fabric, supplementary energy and active control, any building type can be described and the consequences of its bias to any mode of control (passive, active-occupant, active-electromechanical) device can be analysed.

9.2.3 Trends within the matrix and artificial evolution

The surface defined within the matrix is, at this stage, hypothetical and only intended as a theoretical framework. However if indices of the dimensions could be formulated then the actual environmental performance of buildings could be plotted on the matrix and the surface within the matrix determined by empirical data.

A high degree of accuracy in determining the location of building types within the matrix is unnecessary. Such a matrix is not intended to be employed in order to render quantifiable criteria of a particular building type but to illustrate its environmental performance relative to other building types.

The school typologies (figure 8.5a) can be plotted on the surface (although in practice they would determine the surface) and the environmental consequences of any type can be analysed.

For example type I has a compact plan with fairly typical room depths for classrooms. The form dimension has therefore a relatively low value, referring to the indices described in section 9.2.2., whereas the fabric dimension is relatively high as this type is of traditional construction with high thermal inertia and low percentage glazing. Translating this to the surface within the matrix will describe the environmental performance of this type (figure 9.2.2a).

A similar analysis can be carried out on the other school types using the descriptions set out in section 9.5. I.E.D. building types can also be plotted on the surface. Within the three dimensions of the matrix I.E.D. types lie close to traditional types on the surface. However, they have very different characteristics in terms of the fourth dimension: active control.

Historically there has been a trend firstly away from the passive mode of control while retaining the same level of occupant control, and then a reversion to passive control

while decreasing occupant control. Figures 9.2.2a & b also show areas for which there are no existing types (besides the school types) but which can be assumed to describe good environmental performance. For example the area of predominantly passive control by the buildings form and fabric but allowing active control by the occupants.

By extrapolating from or interpolating between typologies of known environmental performance a rudimentary anatomy of hitherto untried building types may be artificially evolved. With empirical data and more precise indices for the dimensions, the evolutionary process could become more sophisticated and produce synthetic typologies.

9.3 Use of typologies during design

9.3.1 Early Stages of design

In section 8.6 it was argued that an holistic analysis of the environmental performance of building types, although crude, offers a more rational approach to good environmental design than evaluative models employed at the later stages of design.

By classifying building types, in the manner discussed in section 9.2.2., the environmental consequences of choosing any particular type can be analysed. The analysis has an advantage over evaluative models since the dimensions of the matrix are the main variables that the designer manipulates at the early stages of design. Furthermore,

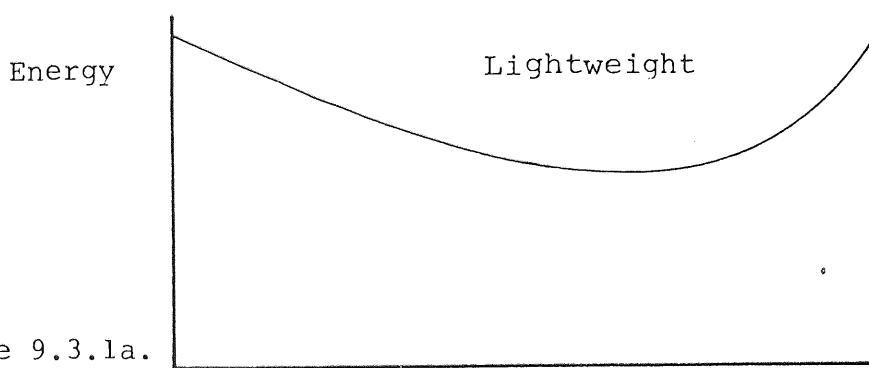

Figure 9.3.1a.

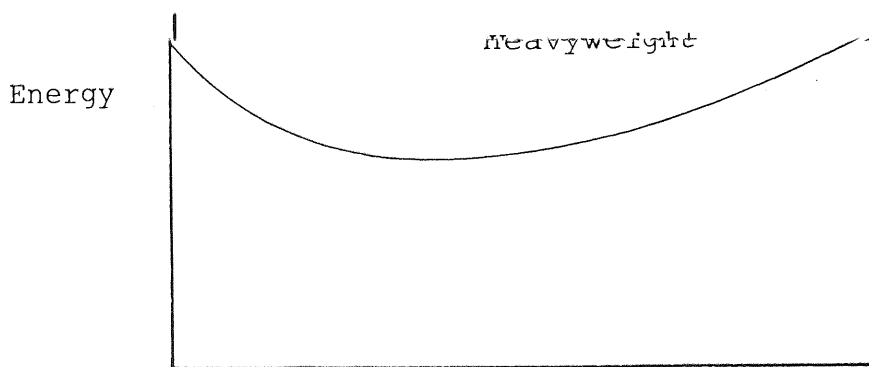

Figure 9.3.1b. DEEP

SHALLOW

Hypothetical Curves of Energy Required for Heavy and Lightweight Buildings Depending on Depth

through a knowledge of the variation of energy consumption intra building types, the designer has not only an estimate of the passive environmental performance but also of the sensitivity of the building to active control.

While the matrix is not intended to be employed in the optimisation of form and fabric it is inevitable that with so few variables optimisation is possible. The intention of the matrix is to illustrate the broad environmental consequences of strategic design decisions. This can be done in two distinct ways: Firstly, by observing whether the design hypothesis conforms to an existing typology already mapped onto the matrix. Secondly, by calculating the approximate position of the design hypothesis in the matrix employing the dimension's indices (section 9.2.2).

For example the matrix may be used to illustrate the arguments of shallow vs deep plan or heavy vs lightweight. Figure 9.3.1a is a plane within the matrix and illustrates the supplementary energy required as a consequence of choosing a deep or shallow plan. With the increase in plan depth the distance of the occupant from the external climate increases (variety reduction, section 3.2) and the level of supplementary energy required increases. With a decrease in plan depth increased supplementary energy is required to counteract excesses of the external climate (e.g. cooling or artificial lighting due to sun blinds). However the shallow vs. deep plan argument is also dependent on the

properties of the building fabric. Within certain limits, decreasing the depth of plan for a heavyweight building may make a corresponding decrease in the requirement of supplementary energy (figure 2.3.1.b). However, for a lightweight building, within the same limits of plan depth, a decrease in plan depth could increase the requirement of supplementary energy (figure 9.3.1.a). Therefore there is an optimum zone for plan depth depending on the building mass.

This zone is further increased by considering not only the supplementary energy required for a given building type but also the environmental performance as measured by the variation in energy consumption intra building types. Figure 8.5.b shows how the mass of a building is related to its sensitivity to environmental modification. A highly glazed building of low thermal inertia is both easily modified and highly responsive to modification. On the other hand a deep-plan heavyweight building that relies almost entirely on supplementary energy may be insensitive to modification particularly if the control mechanisms (e.g. room thermostats or light switches) are inaccessible. Therefore, although the dependence on supplementary energy may be optimised (figures 9.3.1 a & b) for a given combination of the indices of the dimensions form and fabric, the potential for environmental modification by occupants may be sub-optimum.

9.3.2 Typologies at the later stages of design

In section 5.5 it was noted that the external climatic data, in particular of the thermal environment, used by evaluative models could not be used to compare dissimilar building types on a like basis as the different building types have different sensitivities to climatic elements. For example a highly glazed building will be air-temperature, wind velocity and solar radiation sensitive. A building type of high surface: floor area ratio will be wind velocity sensitive both in terms of convective heat loss and air infiltration.

For accurate simulation of the environmental performance of a building type, climatic data may be tempered to account for the sensitivity of any given building type. The classification matrix provides a framework in which climatic data may be tempered. Given a data-bank of external climatic elements, these could be tempered according to the values of the dimensions on the matrix at which the building type under study is located. For example, building type 2 (figure 8.5.a) being highly glazed and having a high surface: floor area ratio and low thermal inertia is sensitive to solar radiation and wind velocity. Whereas an I.E.D. building type will not be so sensitive to these elements but may be more sensitive to air temperature.

A similar argument applies to data for occupant response. In section 4.7 it was noted that occupant control action was dependent on the available control mechanisms. The

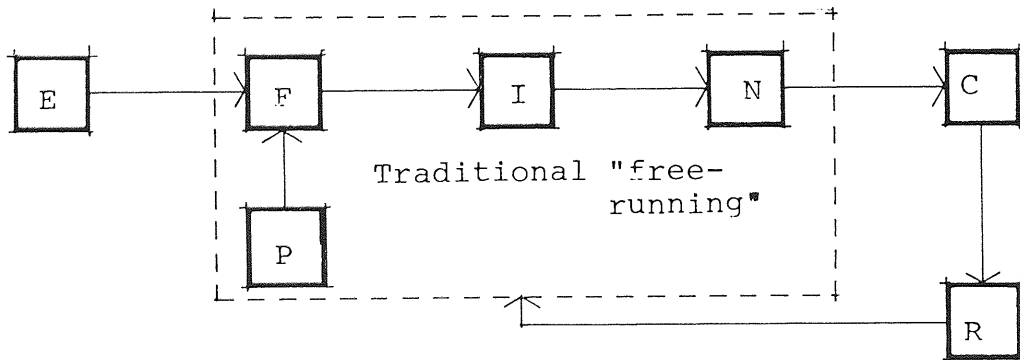

Figure 9.3.2a.

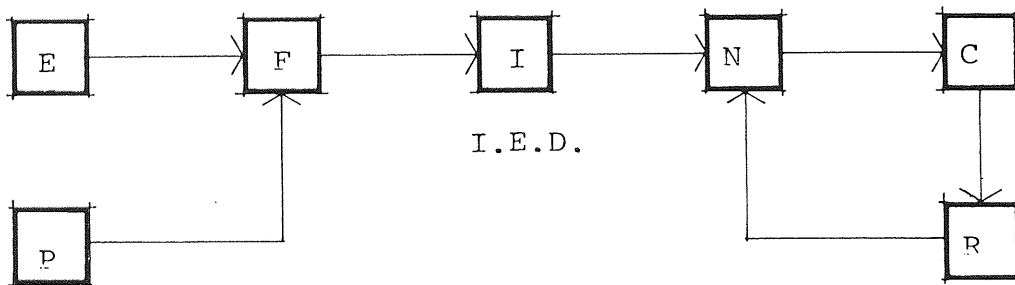

Figure 9.3.2b.

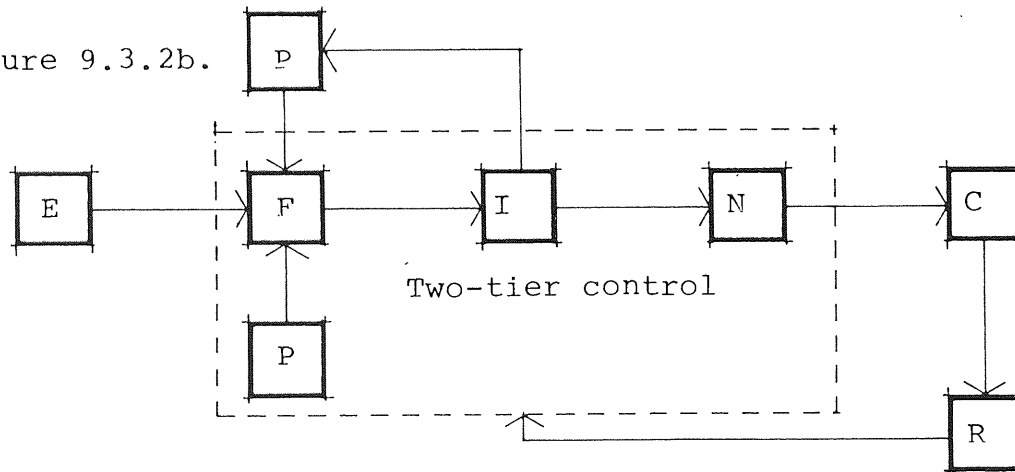

Figure 9.3.2c. The Structure of the Control Systems of three Different Building typologies

(see Figure 3.6 for key)

type and availability of controls is building type dependant and therefore occupant response data can be tempered according to the values of the dimensions of figure 9.2.2.b. For example I.E.D. building types will require different data than school-type 2 to predict occupant response as they are at opposite extremes of the matrix.

Furthermore the structure of the models required to describe the differing predominance in mode of environmental control will vary depending on building type. Figure 9.3.2 illustrates the structures of three different modes of environmental control which can be directly related to the matrix (figure 9.2.2.b) of active control action.

Not only will the use of the classification system aid in more accurate simulation but it also offers the designer a logical step from the initial design hypothesis of the performance of a building type to its detailed analysis at the later stages of design. The system offers both an approximate prediction at the early stages and a framework for accurate prediction at the later stages.

9.3.3 Limitations of building typologies

The intended use of typologies is not necessarily to promote individual types but to demonstrate the environmental consequences of the gross characteristics of form and fabric of a building and its sensitivity to modification.

It may be argued (e.g. Hawkes, 1970b) that such an approach is deterministic as it will inevitably lead to optimised solutions due to a restricted description of the characteristics of typologies. However, in sections 2.3 and 6.5 it was argued that the alternative approach of employing conventional environmental models is equally deterministic since these models were developed in response to shortcomings of specific building types. Predictions based on these models will therefore be erroneous if applied to different building types. Thus although both approaches are deterministic the extent to which the typological approach will predetermine a design is partly dependent on its detailed presentation since it is essentially an illustrative rather than mathematical model.

The argument that typologies are deterministic is especially valid in the process of extrapolation or artificial evolution based on existing types (section 9.2.3). The description or prediction of environmental performance within the context of existing typologies is normative and is therefore unable to describe the performance of radically different typologies. For example, the effects of a combination of environmental control by electro-mechanical devices and occupants cannot be modelled with reference to existing typologies. The only alternative apart from trial and error being simulation by conventional mathematical models (Willey, 1979).

Therefore, while the matrix describing the performance of typologies may aid in predicting the environmental performance of existing types or hybrids within existing types, it is

essentially normative and can only be used to speculate on the form and performance of hitherto untried building types.

9.4 Prospects and further research

Models that are intended to improve environmental design have inherent conflicts. Prescription offers a more rational approach to good environmental design than evaluation, but evaluation is more accurate than prescription. The accuracy of models is inversely related to their convenience of use in design, but most strategic environmental decisions are made before accurate models can be employed.

These conflicts described in section 1.2 (convenience vs. accuracy, strategy vs. tactics and prescription vs. evaluation) cannot be overcome by traditional environmental models. However, the classification system for building typologies bridges these conflicts and offers designers an approach to identifying an environmentally good solution at the early stages of design and a logical progression to its accurate evaluation at the later stages.

Furthermore, the classification system can be used as a research tool to generate synthetic typologies by interpolation and extrapolation from existing typologies. The synthetically evolved typologies can then be more accurately evaluated and, as they have not been generated with the aid of evaluative models (section 2.3), the analysis will not suffer from the Oedipean effect.

The use of the classification system for prescription, evaluation and as a research tool provides, at present, only a conceptual framework because the dimensions that describe the typologies and their environmental performance are rudimentary. However, further research into:

- 1 holistic measures of environmental performance,
- 2 the relationship between the control mechanisms of a building type and its environmental performance and
- 3 the relationship between building types and their sensitivity to climatic elements

would allow dimensions of the matrix to be refined and evolved by feedback from its application.

9.5 Summary

A classification system in the form of a matrix is described for comparing building typologies in terms of their environmental performance. The dimensions of the matrix are derived from the concept of 'variety reduction' and describe a building in terms of form, fabric, use of supplementary energy and active control modes.

It is argued that by employing such holistic measures as the variation in energy consumption intra building-type, the dimensions of the matrix could be quantified. Such a matrix would not be required to have a high degree of accuracy since it is the location of building types relative to each other that is important in describing the environmental consequences of any one type.

The matrix could then be used to:

- a predict the broad environmental consequences of a particular building type relative to others,
- b describe trends in the environmental control system of buildings,
- c artificially evolve building types and
- d provide a framework for more accurate simulation of environmental performance.

As an aid in design the matrix offers a solution field in which the environmental performance of building typologies can be identified at the early stages of design. It also offers a logical progression to a more accurate evaluation at the later stages of design.

CHAPTER 10

EPILOGUE: TYPOLOGIES AND MORPHOLOGIES

10.1 Prospects for Typological Analysis

The purpose that the analysis of building typologies should be used as an aid in environmental design does not exclude the use of conventional environmental models. The two types of models are intended for use at different stages of the design process: building typologies as an aid in the generation of the initial hypothesis and evaluative models to test parts of the hypothesis. They therefore complement each other since a typological analysis offers an outline strategy that can be refined by evaluative models. Without the initial strategy, evaluative models are limited in their scope of improving environmental performance.

The analysis of building typologies, in particular sensitivity analysis, also complements research concerning dynamic modelling. Field studies (such as those described in Chapter 8) measure the effect of occupant interaction and the responsiveness of a building to control actions whereas models of dynamic environmental performance require a knowledge of the cause of occupant interaction. Existing methods of analysing the cause of occupant interaction (Chapter 4) are crude but may be refined from a knowledge of the effect of interaction derived from field studies.

A further area of research that can be aided by typological analysis is building morphology and the environmental impact of certain characteristics of the buildings anatomy. For example, the classification matrix (figure 9) was composed of indices that describe certain characteristics of form and fabric. These indices could be extended by the results of field studies of large samples of building types. By controlling many of the major variables of form and fabric by selective sampling the environmental impact of certain uncontrolled variables (eg: proportion and distribution of glazing, thermal inertia of building fabric and aspects of form) can be studied.

The purpose of such an analysis is not to promote individual building types but to identify the extent to which certain gross characteristics of built form, that are decided during the early stages of design, influence the environmental performance of buildings. By understanding the anatomy of existing building types, with particular reference to energy conservation and environmental performance, new types can be artificially evolved.

Typological analysis is concerned with whole buildings and the theoretical framework (Chapter 9) offers a way in which to analyse the significance of the parts of a building to the whole. This has the advantage over conventional environmental models which, although less crude, have theoretical inaccuracies and are only concerned with selected parts of a building. The essential difference is that typological analysis is concerned with architectural

science and building species whereas conventional models are concerned with building science and only part of a building's anatomy (Note 1).

10.2 The anatomy of buildings and evolution of environmental modelling

Due to the restricted number of variables considered by conventional models and their bias to quantifiable criteria there has inevitably been an 'optimum' solution for the various generations of models (although the conflicting requirements of buildings have made this optimum fairly broad, eg: 20-40% glazing). For example 'steady state' models have promoted cube like buildings to conserve energy (Page, 1974 and March, 1972) with an even distribution of glazing on building facades and no consideration of orientation. This generation (steady-state) of models is still predominant in education and practice (Note 2).

The present generation of models is concerned with dynamic environmental performance, in particular the dynamic characteristics of the external climate. This has put more emphasis on the orientation and distribution of fenestration as well as the thermal inertia of a building (eg: 'E.S.P.', Clarke and Forrest, 1978 or 'BUILD' Page and Jones, 1979). While this generation of models may help, both by throwing out some of the design lore derived from steady-state models and in predicting the cost-effectiveness of electro-mechanical control systems (eg: optimum stop/start or automatic dimming of lights), the results obtained from

such models are of little aid during the formative stages of the design process.

However the limitations of both the theory and data of this type^{of} model restrict them from accurately representing environmental performance and may ultimately determine built form erroneously.

The trend in the evolution of modelling is towards the dynamic representation of both the external climate and occupant response to the environmental control system. A morphological study of building types can account for both the dynamic characteristics of climate and occupant behaviour. Empirical studies on building types offer a further insight into the dynamic performance of buildings which overcomes many of the theoretical limitations in modelling discussed in this thesis. And, although such studies are relatively crude compared with computer modelling, their intended use is to aid the early stages of design where simplified information of the impact of form and fabric on environmental performance is required.

Notes

1. The essential difference between 'architectural' and 'building' science, in this case, is that the former accounts for other factors (eg: social, economic and cultural) that influence built form. The latter only considers how the physical environment may influence form and fabric.

2 For example the RIBA calculator promotes steady-state calculations as do the Building Regulations part FF.

BIBLIOGRAPHY

- ABACUS and VALTOS, (1979) Deemed to Satisfy? Architects Journal, Oct., 872-874.
- ALEXANDER, C. (1964) Notes on the Synthesis of Form. Harvard University Press.
- ARCHER, L.B. (1963) Systematic Method for Designers, Design, April, 46-49.
- ARCHER, L.B. (1969) The Structure of the Design Process, in Broadbent, G. and Ward, A. (editors) Design Methods in Architecture, Lund Humphreys, London.
- ARENS, A.E. and Williams, P.B. (1977) The Effect of Wind on Energy Consumption in Buildings, Energy and Buildings, 1, 77-84.
- ARNOLD, D. (1977) Sunlight and Daylight: a Critical Study of a Major Design Constraint. Transaction of the Martin Centre for Architecture and Urban Studies, 2, 49-66.
- ASHBY, W.R. (1956) An Introduction to Cybernetics, London: Chapman and Hall.
- BALDER, J.J. (1957). Erwünschte Leuchtdichten in Büroraumen, Lichttechnik, 9, p. 455.
- BANHAM, R. (1969) The architecture of the well-tempered Environment, London: The Architectural Press.
- BAXTER, A.J. (1978) SPEED - an Early Design Tool for Building Services. Computer-aided Design, 10 (3), 185-191.
- BAXTER, A.J. (1979) Windows and Energy, Second International CIB Symposium on Energy Conservation in the Built Environment, Copenhagen, pp. 269-280.
- BLACKWELL, H.R. (1970) Additional Visual Performance Data for use in Illumination Specification Systems. Illum. Engng, 65, p. 389.
- BOYCE, P.R. (1975) The Luminous Environment, in Canter, D. (editor), Environmental Interaction, Surrey University Press: London.
- BROADBENT, G. (1969) An Environmental Design Method in Broadbent, G. and Ward, A. Design Methods in Architecture, Architectural Association Paper No. 4; London: Lund Humphries.
- BROADBENT, G. (1973) Methodology in the Service of Delight, Environmental Design Research Association, 2 p. 314.
- BROADBENT, G. (1979a) Alexander's Pattern Language, Architectural Association Quarterly, 11 (4) 58-59.

- BROADBENT, G. (1979b) The Deep Structures of Architecture in Broadbent, G., Bunt, R. and Jencks, C. (editors) Signs, Symbols and Architecture, John Wiley and Sons: New York.
- BRUNDRETT, G.W. (1976) Ventilation: a Behavioural Approach In Courtney, R. (editor), Energy Conservation and the Built Environment (1976, C.I.B. International Symposium), Lancaster: The Construction Press.
- BUILDING PERFORMANCE RESEARCH UNIT (1972) Building Performance, London: Applied Science Publishers.
- BUILDING RESEARCH STATION, (1964) Estimating Daylight in Buildings, BRS, Digests 41 and 42: HMSO.
- BYRD, H. and HILDON, A. (1979) Daylighting: Appraisal at the Early Design Stages. Lighting Research and Technology, 11, (2), 99-101.
- CANTER, D. (1972) Royal Hospital for Sick Children: A Psychological Analysis, Architect's Journal, 6 September, 525-564.
- CHADDOCH, J.B. (1980) Experience of Energy Conservation in Buildings. C.I.B.S. Conference, Nottingham, p. 137.
- CHOMSKY, N. (1971) Deep Structure, Surface Structure and Semantic Interpretation, in Steinberg, D.D. and Jakobovits (editors), Semantics: An Interdisciplinary Reader, Cambridge University Press, Cambridge.
- CLARKE, J. AND FOREST, I. (1978) Validation of the E.S.P. Thermal Simulation Program. Report I (August), A.B.A.C.U.S. University of Strathclyde, Occasional Paper No. 61.
- COLE, R.J. (1976a) The Longwave Radiative Environment Around Buildings, Building and Environment, 11, 3-13.
- COLE, R.J. (1976b) Climatic Data for Predicting the Energy Requirements of Buildings, Report Prepared for the Science Research Council, Building Sub-Committee.
- CANTER, D. (1975) Buildings in Use: Canter, D. (editor) Environmental Interaction, London: Surrey University Press
- COLQUHOUN, A. (1969) Typology and Design Method, in Jencks, C. and Baird, G. (editors) Meaning in Architecture, 266-277, Barrie and Rockliff, London.
- CRISP, V.H.C. and LYNES, J.A. (1980) A model of Daylight Availability for Daylighting Design. CIB's National lighting conference, University of Kent, pp. CF1-10.
- CROGHAN, D. and HAWKES, D.U. (1969) Daylight in Dwellings, Architects Journal Feb. 26th, 585-589.

CROWE, R.V. and Page, P.A. (1976) Integrated Environmental Design of Schools, in Courtney, R. (editor), Energy Conservation in the Built Environment (1976 CIB Symposium), Lancaster, The Construction Press.

DESIGN OFFICE CONSORTIUM (1978) Computer Program for Day-lighting in Buildings, Evaluation Report No. 3. Guildhall Place, Cambridge.

DUFTON, A.F. (1946) Protractors for the Computation of Daylight Factors, D.S.I.R. Building Research, Technical Paper No. 28. H.M.S.O.

ECHENIQUE, M. (1968) Models: a discussion, Land Use and Built Form Studies Working Paper No. 6, University of Cambridge.

FANGER, P.O. (1970) Conditions for Thermal Comfort: Introduction of a General Comfort Equation; in Hardy, J.D. et al (editors), Physiological and Behavioural Temperature Regulation, Springfield Illinois: Thomas.

FLYNN, J.E., SPENCER, T.J., MARTYNIUK, D., and HENDRICK, C. (1973). Interim Study of Procedures for Investigating the Effect of Light on Impression and Behaviour, Journal of the Illuminating Engineering Society (New York), 3, 87-94.

GAGGE, A.P., STOLWIJK, J.A.J. and HARDY, J.D. (1967) Comfort and Thermal Sensations and Associated Physiological Responses at Various Ambient Temperatures, Environmental Research, 1, 1-20.

GERLACH, K.A. (1974) Environmental Design to Counter Occupational Boredom, Journal of Architectural Research, 3 (3), 15-19.

GIVONI, B. (1969) Man, Climate and Architecture, London: Elsevier.

GRANUM, H., MARKUS, T.A. MORRIS, E., CLARKE, J. AND MCGEORGE, D. (1979) The Performance and Economics of Single and Double Glazing in Britain and Scandinavia, a Window Chess-game, Second CIB Symposium on Energy Conservation in the Built Environment. Copenhagen pp. 111-130.

GREENWOOD, P. (1971) The Interpretation of Meteorological Data for Environmental Design. M.Sc. Thesis, University of Wales.

GRIFFITHS, I.D. (1975) The Thermal Environment; in Canter, D. (editor), Environmental Interaction, London: Surrey University Press.

HAIGH, D.M. (1977) Form and Performance, Transactions of the Martin Centre for Architectural and Urban Studies, 2, 137-161.

- HAIGH, D.M. (1980) User Response in Environmental Control, Report to the Science Research Council, Cambridge: the Martin Centre for Architectural and Urban Studies.
- HARDY, A.C. (1966) Environmental Design of Buildings, Science Journal, Sept.
- HARDY, A.C. and O'SULLIVAN, P.E. (1967) The Building - a Climatic Modifier, Proceedings of the Institution of Mechanical Engineers, 182 (Part 3E), 40-46.
- HAWKES, D.U. (1970a) A History of Models of the Environment in Buildings, Land Use and Built Form Studies Working Paper 34, University of Cambridge.
- HAWKES, D.U. (1970b) The Use of an Evaluative Model in Architectural Design: Case Studies. Land Use and Built Form Studies, Working Paper No. 31, University of Cambridge.
- HAWKES, D.U. (1976a) Modelling Environmental Performance; in March, L. (editor) The Architecture of Form, Cambridge, Cambridge University Press.
- HAWKES, D.U. (1976b) Types, Norms and Habit in Environmental Design, in March L. (editor), The Architecture of Form, Cambridge University Press, Cambridge.
- HAWKES, D.U. (1978) Stereotypes: And the Production of Designs in Architecture, A Talk given at Manchester University, May 1978.
- HAWKES, D.U. and MACCORMAC, R. (1978) Office Form, Energy and Land Use. R.I.B.A. Journal, 85 (June), 246-248.
- HAWKES, D.U. and WILLEY, H. (1977) User Response in the Environmental Control System, Transactions of the Martin Centre for Architectural and Urban Studies, 2, 111-135.
- HILLIER, W. AND LEAMAN, A. (1974) How is Design Possible? Journal of Architectural Research, 3, 4-11.
- HILLIER, W. MUSGROVE, J. AND O'SULLIVAN, P. (1972) Knowledge and Design, Environmental Design Research Association 3, 2, 29.3.1.-14.
- HOLMES, M.J. AND HITCHIN, E.R. (1978) An "Example Year" for the Calculation of Energy Demand in Buildings, Building Services Engineer, 45, 186-189.
- HOPKINSON, R.G. AND LONGMORE, J. (1954) A study of the Interreflection of Daylight Using Model Rooms and Artificial Skies. National Building Studies, Research Paper No. 24. H.M.S.O.
- HUMPHREYS, M.A. (1975) Field Studies of Thermal Comfort Compared and Applied, Building Research Establishment Current Paper, CP76/75.

- HUNT, D.R.G. (1980) The Use of Artificial Lighting in Relation to Daylight Levels and Occupancy. Building and Environment, 14, 21-33.
- JONES, J.C. (1965) Systematic Design Methods and the Building Design Process, Architects Journal, 22 Sept., 685-687.
- KEIGHLEY, E.C. (1970) Acceptability Criteria for Noise in Large Offices, Journal of Sound and Vibration, 11 (1) 83-93.
- KERR, R. (1865) On Ancient Lights and the Evidence of Surveys Thereon. John Murray, London.
- KOENIGSBERGER, O. (1978) Architectural Science for Practitioners. Architectural Science Review 21 (1), 6-7.
- KOENIGSBERGER, O., INGERSOLL, T.G., MAYHEW, A. AND SZOKOLAY, S.V. (1973) Manual of Tropical Housing and Building, Part One, London: Longman.
- LACY, R.E. (1977) Climate and Building in Britain. Building Research Establishment Report, H.M.S.O. London.
- LANGDON, F.J. (1966) Modern Offices: a User Survey, National Building Studies Research Paper 41, H.M.S.O. London.
- LANGDON, F.J. (1977) Noise, Nuisance Caused by Road Traffic in Residential Areas, Building Research Establishment Current Paper, CP 10/77.
- LAWSON, B. (1980) How Designers Think, The Architectural Press Ltd: London.
- LOUDON, A.G. (1968) Summertime Temperatures in Buildings, B.R.S. Current Paper 47/68.
- LOUDON, A. (1980) Overheated Houses, Building Services, 2 (2), 45.
- LUND, H. (1975) Test Reference Year - Weather Data for Environmental Engineering and Energy Consumption in Buildings, Technical University of Denmark.
- LYNES, J.A., BURT, W., JACKSON, G.K., AND CUTTLE, C. (1966) The Flow of Light into Buildings. Trans. Illum. Eng. Soc. 31, 65-91.
- MANNING, P.B. (1965) Office Design: a study of Environment, Pilkinton Research Unit, University of Liverpool Department of Building Science.
- MARCH, L. (1972) Elementary Models of Built Forms, in Martin, L. and March, L. (editors) Urban Space and Structures. Cambridge University Press.

- MARCH, L. (1976) The Logic of Design and the Question of Value; in March, L. (editor), The Architecture of Form, Cambridge University Press: Cambridge.
- MARKUS, T.A. (1979) The Window as an Element in the Building Envelope; Techniques for Optimisation. Second CIB Symposium on Energy Conservation in the Built Environment, Copenhagen.
- MILBANK, N.C. AND PETHERBRIDGE, P. (1974) Graphical Aids for the Early Stages of Building Design, Building International 7 (4), 333-347.
- MILNE, M.A. (1972) The Beginnings of a Theory of Environmental Control. Environmental Design Research Association 3, 2, 25.4.1-5.
- MOLESWORTH, H.B. (1902) Obstruction to Light. Spon, London.
- MOON, P. AND SPENCER, D.E. (1942) Illumination from a non-uniform Sky. Illuminating Engineer, 37 (12), 707.726.
- NICOL, J.F. AND HUMPHREYS, M.A. (1973) Thermal Comfort as Part of a Self-regulating System, Building Research and Practice, 1 (3), 174-179.
- NICOL, K. (1977) The Energy Balance of an Exterior Window Surface, Building and Environment, 12, 215-219.
- NIGHTINGALE, F. (1959) Notes on Hospitals, see Hopkinson, R., Petherbridge, P., and Longmore, J. (1968) Daylighting, p. 403; Heinemann Ltd.
- OLGYAY, V. (1963) Design with Climate: Bioclimate Approach to Architectural Regionalism, New Jersey: Princeton University Press.
- O'SULLIVAN, P. (1970) Heat Islands in Cities, Architectural Research and Teaching, May, 13-24.
- O'SULLIVAN, P. (1978) Environmental Myths - So Far No Further, Architectural Science Review, 21 (4), 98-101.
- PAGE, J.K. (1974) The Optimisation of Building Shape to Conserve Energy, Journal of Architectural Research, 3 (3) 20-28.
- PAGE, J.K. (1976) Application of Building Climatology to the Problems of Housing and Building for Human Settlements. World Meteorological Organisation: Technical Report No. 150.
- PAGE, P. AND JONES, A. (1979) Energy Conservation and Management in Building Design-Schools. Second CIB Symposium on Energy Conservation in the Built Environment pp. 289-300.

- PERKINS, M., ROBERTS, N. AND GALLOWAY, P. (1977) Towards an Energy Norm: An Examination of Energy Consumption in Standard Primary Schools, on Energy Management Within Local Authorities, Conference Proceedings, N.E.L.P., Nov. 22.
- RADFORD, A.D. AND GEPO, J.S. (1980) Tradeoff Diagrams for the Integrated Design of the Physical Environment in Buildings. Building and Environment, 15, 3-15.
- RITTEL, H.W.J. (1972) Dilemmas in a General Theory of Planning, DMG-DRS Journal, 8 (7), 31-39.
- SAUNDERS, J.E. (1969) The Role of the Level and Diversity of Horizontal Illumination in an Appraisal of a Simple Office Task. Lighting Research and Technology, 1, p. 37.
- STEADMAN, P. (1973) Graph² Theoretic Representation of Architectural Arrangement, Architectural Research and Teaching, 2, 161-172.
- STEADMAN, P. (1975) Models in our Heads, Models in the Material World and Models in the World of Objective Knowledge, in Hawkes, D. (editor) Models and Systems in Architecture and Building. LUBFS Conference Proceedings No. 2. Construction Press Ltd., Lancaster.
- STEADMAN, P. (1979) The Evolution of Designs, Cambridge University Press, Cambridge.
- Study Group Appointed by H.M. Treasury, (1947) Working Conditions in the Civil Service, HMSO.
- STURROCK, N.S. (1971) Localised Boundary Heat Transfer from External Building Surfaces. Ph.D. Thesis, University of Liverpool.
- WALDRAM, P.J. AND J.M. (1923). Window Design and the Measurement and Predetermination of Daylight Illumination. Illum. Engn., 16, p. 90.
- WELFORD, A.T. (1968) Fundamentals of Skill, London, Methuen.
- WESTON, H.C. (1949) Sight, Light and Work, H.K. Lewis, London.
- WILLEY, H.B. (1978) A Theoretical Framework of Environmental Control. Ph.D. Thesis, Cambridge University.
- WILLEY, H.B. (1979) Fuzzy Theory and Environmental Control in Buildings, Environment and Planning B, 6, 3: 279-291.

Appendix 1

Abstracts from the original application to the Science Research Council for funding the Research project.

Although these were the original intentions of the project many of the objectives were altered or became redundant during research.

6.1. Aims of the Investigation

In recent years considerable research work has led to the development of numerous predictive techniques relating to environmental conditions within buildings. Many of these techniques are empirical or greatly simplified versions of theoretical models. This is unavoidable for two reasons:-

- i) buildings are not precise machines and can never be, as they are subject to highly variant climates (natural and manmade) and unpredictable use patterns.
- ii) excessive complexity usually precludes practical application by designers.

A wide selection of these techniques are currently taught in Schools of Architecture where their use as design tools (as opposed to postdesign analysis) is encouraged. However, a major component of current vociferous criticism of contemporary architecture revolves around the physical performance of buildings of which poor environmental control is a principal element. This, together with experience within the architectural profession, constitutes evidence that the availability and teaching of environmental science is not matched by its application to the design of buildings. Although there is an almost universally accepted desirability for some form of design aids the overwhelming mass of information and techniques now available inhibits their fluent use necessary in a circular, refining design evolution.

The overall aim of this project is to more accurately diagnose this malady and its causes and, through a rationalisation of environmental science as a dynamic design parameter to evolve a 'package' of techniques and information aimed at increased design application compatible with improved environmental design.

The principal objective then is to identify the true value of current predictive techniques to the designers, through an assessment of their use and accuracy. Secondary objectives related to the previously mentioned package the work should eventually relate to practising architects where the need is for a wide range of techniques dealing with thermal/lighting/acoustics/energy aspects that can be applied as design tools. In addition to the techniques themselves, their accuracy must be assessable, and a simple 'data bank' available.

Proposed Plan of Work

The major elements of the work will be:

- a) Survey of environmental predictive techniques and their current status within building design.
- b) Monitoring/measurement of design application and building performance
- c) Analysis of predictions, the manner in which they are or should be applied, and comparisons with actual performance.

Although these are approximately chronological, because of the multifaceted nature of the work, there will be considerable overlap as particular aspects move forward at different paces dictated by external factors such as buildings/designer availability, since it is clear that an essential ingredient of this work is 'live' buildings and design projects.

It is possible to further subdivide the programme into phases of activity:

1. Collation of techniques, their research and development as predictive methods, previous work (if any) relating their accuracy and actual building performance.
2. Survey the architectural profession to determine attitudes to and degree of use of the various predictive techniques available.
3. Experiments and interviews to assess usability of predictive techniques
4. Selection of:-
 - a) recently completed buildings and their designers and
 - b) design projects about to begin.
5.
 - a) (Completed Buildings) Prediction of a range of environmental parameters using existing techniques applied to 'drawing board information' i.e. using the level of knowledge that would have existed at the relevant stage in the design process. Dialogue with the designer(s) to ascertain the particular design process and the role of environmental science.
 - b) (Design Projects) Prediction of environmental aspects at suitable stages in the design evolution. Monitoring of the design processes through regular evaluation of the design, with particular regard to the diagnostic versus deductive nature of predictive techniques within a dynamic design process.

(Although, computers will be used in this work, predictive computer programmes are not under investigation since the study is concerned with those techniques readily available to the designer at his drawing board i.e. manual techniques)

Completed buildings will be surveyed to determine actual environmental performance. This will involve measurement of various physical parameters associated with thermal acoustic and lighting conditions. In addition factors which influence the parameter being measured will require investigation since these may be different from those envisaged /assumed at the prediction stage.

Comparative analysis of the results of 5 and 6 including circular or refining experiments through stages 5 and 6 in order to study discrepancies identified by the comparative analysis.

Using the results of 7 and experience of 5 attempt to characterise those properties of the environmental prediction that influence its design application viz. accuracy, limitations and constraints, flexibility, degree of data required, sensitivity to building/user/ efficacy/viability of predictive techniques will be paralleled with an identification of modifications necessary to improve design use. Any proposals will be tested by returning to previous phases of the programme.

Appendix 2

The following is a reprint published in Lighting Research and Technology. It is included in this thesis as a requirement of the C.N.A.A.

Summary A method for analysing daylight in buildings is described for use in the early stages of the design process where the conflicting functions of the window can be related through a knowledge of the percentage glazing on a building facade.

Daylighting: appraisal at the early design stages

H. BYRD, BA(Arch.), AND A. HILDON, BA, PhD(Cantab)

1 Introduction

For a building design team concerned with the quality of the internal environment of buildings the percentage area of glazing on a building facade is one of the most useful criteria for judging the building envelope as a modifier of climate at early design stages, since it is at the window that the various environmental parameters (heat, light and sound) remain only minimally modified.

The percentage area of glazing can be used to relate the numerous and often conflicting functions of the window such as the provision of daylight, summer-time temperatures¹, sound insulation², energy efficiency³ and view satisfaction⁴.

2 Predicting daylight

Although several well established techniques for predicting daylight conditions within rooms already exist⁵ these are not compatible with the conjectural processes of the early design stages.

This is in common with other forms of environmental predictive techniques where high precision, inflexibility, time consumption and other properties result in their non-use at the critical stages in the generation of building form^{6, 7}. The designer requires techniques that are essentially 'rules of thumb' to guide and influence decisions made during the conjectural stages of design, the importance and value of such simple and flexible methods being more important than the loss of precision involved⁸. The method described here allows an analysis of daylighting to be done at early design stages and relates the minimum daylight factor (that daylight factor equalled or exceeded over the working plane) to the percentage area of glazing,

depending on room geometry and reflectance. It also allows the uniformity of daylight distribution within the room to be analysed and can yield the area over which supplementary lighting is required if daylighting is inadequate.

3 Criteria for daylighting design

There are essentially three principal criteria for assessing the quantity of daylight within rooms. These are the daylight factor at any point (sky and internally reflected components), the minimum daylight factor and average daylight factor. In terms of accuracy there is little to choose between the different predictive methods but the minimum and average daylight factors are more useful criteria at early design stages as they measure properties of a room rather than any point within a room.

The advantages of the average daylight factor are that it bears a close relationship with the subjective appraisal of lighting in a room⁹ and it is less sensitive to changes in the sky luminance distribution and the positioning of the window in the window-wall. However, while recommendations for daylighting are related to minimum standards applicable to the whole room a knowledge of the minimum daylight factor is important particularly where task lighting is considered.

The main argument against the minimum daylight factor as a design criterion is that by concentrating on achieving adequate amounts of light furthest from the window it can lead to over-fenestration with its attendant problems such as glare, excessive heat losses and gains. However the minimum daylight factor does have advantages where task lighting is required if it is not taken as a criterion in itself but is considered alongside the distribution of daylight in a room through an assessment of uniformity.

The method presented here (Fig. 1) is empirically based and employs the minimum daylight factor as the design criterion. The upper part of the graph relates the minimum daylight factor to the window: floor area ratio for various conditions of

H. Byrd is a research student and A. Hildon, Principal Lecturer in architectural science at the Birmingham School of Architecture, City of Birmingham Polytechnic. The paper was first received on 19 March 1979, and in revised form on 11 May 1979.

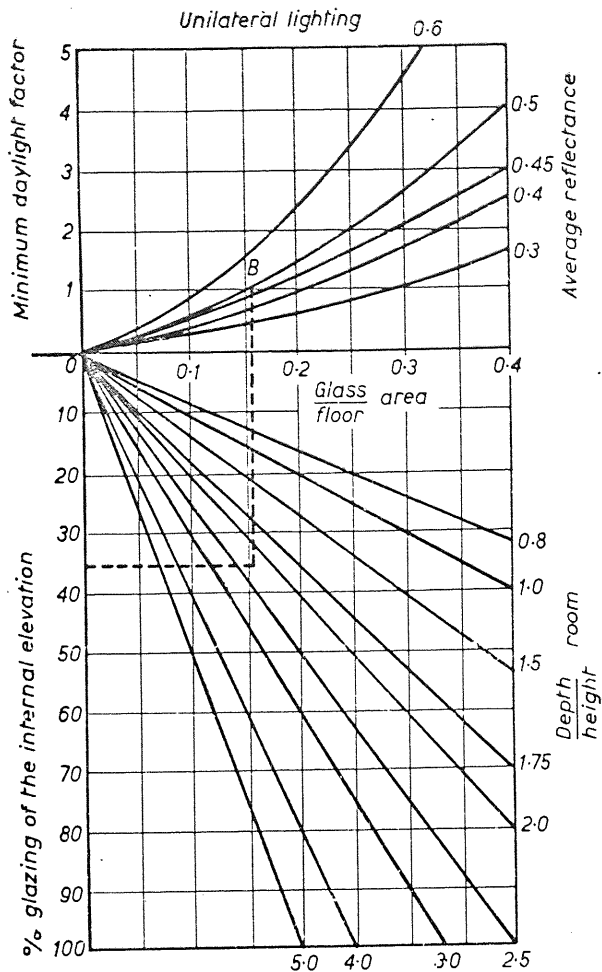

Fig. 1. The minimum daylight factor related to per cent area of glazing of the internal elevation of the window wall.

room reflectance. The lower part of the graph simply relates the window: floor area to the percentage glazing through a knowledge of room geometry.

To complete this method a rule of thumb for assessing uniformity is incorporated.

4 Uniformity of daylighting

Uniformity is essentially a measure of the subjective appraisal of lighting within a room but it is also a measure of efficiency of providing adequate lighting levels without over-glazing. For example, a room may have the required minimum daylight factor but if this is achieved only by an excessive window area then the room may be too deep or dark. The uniformity of daylighting can be measured as the ratios of minimum: average or minimum: maximum daylight factor, although Lynes¹⁰ has produced a formula for the ratio of average daylight factor in the front half of the room: average daylight factor in the back half of the room. The rule of thumb described here uses the ratio of minimum: maximum with a limiting value of 1:10 as this is near the maximum acceptable contrast. The minimum daylight factor is a known quantity (from Fig. 1) and the maximum is easily deduced as it has a constant relationship with the percentage glazing being relatively independent of room conditions. The maximum daylight factor is taken as being 1 m from the window and although this is not a true maximum it covers an area more closely representative of the subjective maximum and

has an approximate value of ten times the window height (metres), assuming the cill level to be on the working plane.

$$\text{Maximum DF: Minimum DF} < 10 \quad (1)$$

$$\text{Max DF} = 10h \quad (2)$$

$$\frac{g}{100} = \frac{w \cdot h}{W \cdot H} \quad (3)$$

From (1), (2) & (3)

$$\frac{g}{\text{min DF}} < 100 \cdot \frac{w \cdot 1}{W \cdot H} \quad (4)$$

where g = percentage area glazing

w = window width

h = window height (metres)

W = room width

H = room height

For typical ceiling heights and positioning of windows the limiting value for acceptable uniformity is

$$\frac{\% \text{ glazing}}{\text{Min DF}} < 30 \quad (5)$$

Even if adequate daylighting is provided the ratio for uniformity may be checked taking the values of minimum daylight factor and percentage glazing from the graph, and if the ratio is excessive then the necessary changes in room geometry and/or reflectance can be quickly calculated.

5 Graphical method

The graph (Fig. 1) consists essentially of four parameters; the minimum daylight factor, the area weighted average reflectance, the Depth: Height ratio of the room and the percentage area of glazing of the window wall. A knowledge of any three will determine the fourth but its most common uses will be for determining percentage glazing or maximum depth of a room for given lighting levels and room conditions. The latter use is particularly relevant to supplementary lighting. The predicted depth of adequate daylighting can be compared with the actual depth of the room and hence the difference will yield the depth of the room requiring supplementary lighting. This may also provide useful data for selective switching or dimming of artificial lighting systems although ultimately other values of sky luminance distribution must be used for a better assessment. This method is intended to be used for integrating those factors involved in producing a building that not only modifies climate for comfort reasons but also for efficient use of energy. While the new building regulations part FF¹¹ may seem heavy handed in restricting glazing they do set targets which can easily be applied to this method, although there can be a trade-off if multiple glazing or rooflights are used.

For example: a typical office of average reflectance 0.5 requires a minimum daylight factor of 1 per cent. If single glazing is to be used and there are no rooflights then the maximum percentage glazing

permitted is 35 per cent if it is to conform to part FF of the building regulations. 35 per cent can therefore be flagged (A) on Fig. 1.

The intersection of 1 per cent minimum daylight factor with the 0.5 reflectance curve can also be located (B). Where the horizontal from A meets the vertical from B the maximum Depth: Height of the room can be read (2.25). If the ceiling height is 3 m then the maximum depth of the room is 6.75 m if it is to achieve a 1 per cent minimum daylight factor.

Similarly, if the Depth: Height ratio is already determined then the percent glazing required to provide the specified minimum daylight factor in the room can be found and checked against other design targets. For instance, checking for uniformity; the ratio (equation 5) will be exceeded for the above example (35:1). By altering the room geometry or reflectance the percentage glazing may be reduced. In this example, if the depth of the room is decreased to 6 m or the reflectance increased to 0.55 then only 30 per cent glazing is required which satisfies the uniformity ratio.

6 Conclusion

In conclusion: the average daylight factor will provide the best criteria for assessing daylighting within a room but only when its method of calculation and recommended values have been agreed upon. But the minimum daylight factor will always remain a useful criterion where task lighting is required.

Acknowledgement

The authors are grateful to A. J. Howrie, Head of Department, for the provision of research facilities and encouragement. H. Byrd is funded by the Science Research Council.

References

- 1 Loudon, A. G., Summertime temperatures in buildings, BRS current paper 47/68 (1968).
- 2 British Standard Institution, Code of Practice, B. S. C. P. 3 Chapter III (1960).
- 3 Burberry, P., Building for energy conservation, (Architectural Press, London, 1978).
- 4 Keighley, E. C., Visual requirements and reduced fenestration in offices. B. R. E. current paper 41/74 (1974).
- 5 International recommendations for the calculation of natural daylight. CIE publication No. 16 (1970).
- 6 Predictive techniques in the design process: a survey. Birmingham School of Architecture, Internal Report (1978).
- 7 Croghan, D. & Hawkes, D., Daylighting in dwellings 3 *Archit. J.*, 26 Feb (1969).
- 8 Koenigsberger, O., *Archit. Sci. Rev.* 21, 6 (1978).
- 9 Longmore, J., Daylighting—a current view, *Light Ltg.* 68, 113, (1975).
- 10 Lynes, J. A., *Ltg Res. & Technol*, this issue p 102
- 11 The Building Regulations (first amendment) 1978 part FF.