

If you have discovered material in AURA which is unlawful e.g. breaches copyright, (either yours or that of a third party) or any other law, including but not limited to those relating to patent, trademark, confidentiality, data protection, obscenity, defamation, libel, then please read our [Takedown Policy](#) and [contact the service](#) immediately

ON WAVEFORM ANALYSIS, THE ADAPTIVE TASK  
TECHNIQUE AND THE EFFECT OF VIBRATION  
ON MANUAL CONTROL SKILL

A Thesis Submitted by

Graham Douglas Whitehead MSc.

For The Degree

THESIS  
159.944

184897 29 MAR 1978 WHI

DOCTOR OF PHILOSOPHY

University of Aston in Birmingham

December 1972

ON WAVEFORM ANALYSIS, THE ADAPTIVE TASK TECHNIQUE AND THE EFFECT  
OF VIBRATION ON MANUAL CONTROL SKILL

Summary

A re-examination of fundamental concepts and a formal structuring of the waveform analysis problem is presented in Part I. eg. the nature of frequency is examined and a novel alternative to the classical methods of detection proposed and implemented which has the advantage of speed and independence from amplitude. Waveform analysis provides the link between Parts I and II. Part II is devoted to Human Factors and the Adaptive Task Technique. The Historical, Technical and Intellectual development of the technique is traced in a review which examines the evidence of its advantages relative to non-adaptive fixed task methods of training, skill assessment and man-machine optimisation. A second review examines research evidence on the effect of vibration on manual control ability. Findings are presented in terms of percentage increment or decrement in performance relative to performance without vibration in the range 0-0.6Rms'g'. Primary task performance was found to vary by as much as 90% between tasks at the same Rms'g'. Differences in task difficulty accounted for this difference. Within tasks vibration-added-difficulty accounted for the effects of vibration intensity. Secondary tasks were found to be largely insensitive to vibration except secondaries which involved fine manual adjustment of minor controls.

Three experiments are reported next in which an adaptive technique was used to measure the % task difficulty added by vertical random

and sinusoidal vibration to a 'Critical' Compensatory Tracking task. At vibration intensities between 0 - 0.09 Rms 'g' it was found that random vibration added  $(24.5 \times \text{Rms 'g'}) / 7.4 \times 100\%$  to the difficulty of the control task. An equivalence relationship between Random and Sinusoidal vibration effects was established based upon added task difficulty. Waveform Analyses which were applied to the experimental data served to validate Phase Plane analysis and uncovered the development of a control and possibly a vibration isolation strategy. The submission ends with an appraisal of subjects mentioned in the thesis title.



## A C K N O W L E D G E M E N T S .

The Author is indebted to several organisations and individuals and wishes to acknowledge the contribution made by each. The Human Engineering Division, R.A.E., Farnborough provided the task waveform generator and the Author is particularly indebted to Mr. Bob Thorn of that Dept. whose enthusiasm and encouragement it was that led to a study of the Adaptive Task Technique. Dr. Cedric Ashley of the University of Birmingham was responsible for loaning the vibration facility and much ancillary equipment. The hospitality provided by Dr. Ashley and the spirit of cooperation exhibited by himself and his staff throughout the development and experimental trial periods was exemplary. The experimental period was indeed a pleasure! For the use of analog spectrum analysis equipment the author wishes to thank Prof. Downham of the Mech. Eng. Dept. at Aston whose trust in allowing his laboratory to be 'invaded' was most encouraging. Miss Jaqueline Shane of the Institute of Computer Science, University of London wrote the program and transferred recorded data on Atlas to ICL tape. In the formative stages of report writing discussion with Dr. E.C. Poulton of the M.R.C. Applied Psychology Research Unit proved particularly helpful.

Part I was typed by Miss Ann Love who, as secretary to my Supervisor, Prof. W.T.Singleton, I owe a special debt of gratitude for keeping in touch during typing. To my supervisor and my many former colleagues at Aston I am grateful for the stimulation that resulted from our many discussions. To Prof. Singleton I am especially grateful for the opportunity to submit this thesis, for the motivation provided by

his example and for his persistent faith in believing that one day it would be complete. Finally to my wife, Ann, who typed the second Part and who, throughout, has been a constant source of inspiration, my sincere thanks.

## SECTION HEADINGS

GENERAL INTRODUCTION	1
PART I. The description and interpretation of continuous random variables (waveforms) in neuropsychology and ergonomic research.	
1.0 Introduction	7
2.0 The treatment of waveforms	21
3.0 Waveform alternatives and quantification (what can occur in a waveform)	24
4.0 The description of features and patterns of occurrence in a waveform	79
PART II. A study of the effects of whole body vibration on manual control capability using the adaptive task technique	
2.1. Introduction	132
2.2. A review and a history of the adaptive task technique	136
2.3. A review of the effect of whole body vibration on manual control capability	167
EXPERIMENTAL RESEARCH	
2.4. Development of an adaptive task	242
2.5. The experimental facility	272
2.6. Experiment I. On the effect of random vertical vibration on the difficulty of a manual control task	284
2.7. Experiment II. On the relationship between acceleration and frequency of sinusoidal vibration and the manageable difficulty of a manual control task	393

2.8.	Experiment III. On the development of control strategy during adaptive random vibration	400
2.9.	Appraisal I. On the effect of whole body vibration on manual control performance	422
2.10.	Appraisal II. On the adaptive task technique	428
2.11.	Appraisal III. On waveform analysis	430
	Appendix A.	433
	Appendix B.	444
	Appendix C.	482
	Appendix D.	530
	References	533

# C O N T E N T S

SUMMARY

ACKNOWLEDGEMENTS

GENERAL INTRODUCTION

1.

PART I. The description and interpretation of continuous random variables (waveforms) in neuropsychology and ergonomics research.

1.0.	Introduction	7
1.1.	Importance of waveforms	7
1.2.	The value of waveforms	11
1.3.	Summary of aims for Part I	18
1.4.	Motivation	19
2.0.	The treatment of waveforms	21
2.1.	The role of waveforms in Human Factors and Biomedical research.	21
3.0.	Waveform alternatives and quantification. (what can occur in a waveform)	24
3.1.	Time translation	27
3.2.	The nature of frequency	29
3.2.1.	Instantaneous frequency spectrum	34
3.2.2.	The separation of frequency from amplitude	46
3.2.3.	Frequency scale unit	48
3.2.4.	An alternative definition of frequency	50
3.3.	The Wiener/Khinchine method of frequency detection	70
3.4.	The transition of state in a waveform	73
3.5.	Summary	74.

4.0.	The description of features and patterns of occurrence in a waveform	79
4.1.	Occurance relationships	80
	Table I	83
4.2.	Basic occurrence relationships	85
	4.2.1. Elementary occurance	85
	4.2.2. Statistical relationships	87
	Moving Average	92
	4.2.3. Transformation relationships	94
	Orthogonal relationships	95
	Permutation relationships	96
	4.2.4. Functional relationships	97
	Descriptive functionals	98
	Non-linear regression	99
	Transfer functionals	100
	Fokker Plank equation	
	Table II	123
4.3.	Description of the temporal structure (see ref.2)	124
	Table III	125
PART II. A study of the effects of whole body vibration on manual control capability using the adaptive task technique.		
		132.
2.1.	Introduction	132.
2.2.	A review and a history of the adaptive task technique	136
	2.2.1. Technical development	154
	2.2.2. Strategies of adaptive change	156

2.2.3.	Performance measurement	161
2.2.4.	The nature of learning with adaptive tasks	161
2.2.5.	Motivation	163
2.2.6.	Relative advantages	164
2.3.	A review of the effect of whole body vibration on manual control capability	167
2.3.1.	Introduction	167
2.3.2.	Control skill	169
2.3.3.	Psychomotor skill	170
2.3.4.	Procedural skill	171
2.3.5.	Time sharing skill	171
2.3.6.	Assessment of control skill	172
2.3.7.	The breadth of evidence	173
2.3.8.	Simulation studies	175
	Performance effects	180
2.3.8.1.	Duration	185
2.3.8.2.	Recovery	185
2.3.8.3.	Task difficulty	185
2.3.8.4.	Tracking axes	186
2.3.8.5.	Physiological effects	187
2.3.8.6.	Vibration spectrum	187
2.3.8.7.	Stationary and non-stationary vibration	188
2.3.8.8.	Closed loop vibration	188
2.3.8.9.	Summary	189
2.3.8.10.	Assessment	191
2.3.8.11.	Conclusion	192
2.3.9.	Related simulation and random vibration studies	193
2.3.9.1.	Tasks, experimental conditions and results	197

2.3.9.2. Assessment	
Vertical vibration primary task effects	216
Secondary task performance	218
Tracking axes	219
Duration and non-stationarity	221
Task difficulty	221
Transmissibility	224
Controls	225
Subject experience	225
Arousal	225
Multi axis vibration	227
The significance of vibration effects	229
2.3.10. Random v sinusoidal effects	231
2.3.11. Sinusoidal studies	237
EXPERIMENTAL RESEARCH	
2.4. Development of an adaptive task	242
2.4.1. Task theory	242
2.4.2. Controlled element dynamics	243
2.4.3. Task difficulty	244
2.4.4. Dynamic analysis and the human operator describing function	246
2.4.5. Command input	252
2.4.6. The performance measure	253
2.4.7. The performance standard	253
2.4.8. The adaptive logic	253
2.4.9. Display	256
2.4.10. Control	256
2.4.11. Task development	258



2.4.12.	Adaptive logic	258
2.4.13.	Performance standard parameter	259
2.4.14.	Learning	261
2.4.15.	Briefing	268
2.5.	Experimental facility	272
2.5.1.	Vibration	272
	Vibration waveforms	272
2.5.2.	Adaptive vibration	275
2.5.3.	Seat	275
2.5.4.	Vibration measurement and calibration	275
2.5.5.	Physiological measurement	277
2.5.6.	Recording	277
2.5.7.	Measurement Accuracy	279
2.5.8.	Communication	280
2.5.9.	Experimentors station	280
2.5.10.	Subject safety	281
2.5.11.	Task environment	283
2.6.	Experiment I. On the effect of random vertical vibration on the difficulty of a manual control task	284
2.6.1.	Subjects	284
2.6.2.	Waveform analysis considerations	284
2.6.3.	Experimental design	286
2.6.4.	Vibration	286
2.6.5.	Proceedure	289
2.6.6.	Results	295
2.6.7.	Group average results	297
2.6.8.	Individual results	299

2.6.9.	Data analysis	300
2.6.10.	Analysis of ECG records	300
2.6.11.	Analysis of task and vibration data	300
2.6.12.	The results of analysis	303
2.6.12.1.	Heart rate	303
2.6.12.2.	Task variables	306
Amplitude analysis		306
Zero crossing analysis		309
Correlation-time delay analysis		309
Spectrum analysis		314
Phase plane analysis		355
2.6.12.3.	Vibration	368
Input vibration		375
Head vibration and transmissibility		375
2.6.12.4.	Visual inspection of records	383
2.6.13.	Summary of results and conclusions	385
Describing function analysis		388
Arousal		389
Waveform analysis		390
2.7.	Experiment II. On the relationship between acceleration and frequency of sinusoidal vibration and the manageable difficulty of a manual control task.	393
2.7.1.	Vibration	393
2.7.2.	Subjects	394
2.7.3.	Procedure	394
2.7.4.	Results	397
2.7.5.	Conclusions	399

2.8.	Experiment III. On the development of control strategy during adaptive random vibration	400
2.8.1.	Summary and conclusions	420
2.9.	Appraisal I. On the effect of whole body vibration on manual control performance	422
2.10.	Appraisal II. On the adaptive task technique	428
2.11.	Appraisal III. On waveform analysis	430
Appendix A.	Detection of the point centred angular velocity in the phase plane	433
	Analog technique	433
	Digital technique	436
Appendix B.	Computer programs	444
	Fourier Hanning PSD	447
	Fourier Milner PSD	458
	Isometric projection	468
	Phase plane analysis	473
Appendix C.	Estimate uncertainty in waveform analysis	482
Appendix D.	Derivation of the spectral ratios of the human operator and man/machine describing functions	530
<hr/>		
References.	for Part I	533
	for Adaptive task technique	537
	for Effects of vibration on manual control	546
	for Sections 2.4-2.11 and general introduction	555
	Publications by the Author.	

## GENERAL INTRODUCTION.

We are now in the age of real time computer control. The modern airliner, certain military aircraft and space vehicles such as the lunar landing craft are now capable of automatic landing and take off. In all these vehicles the human operator can override the control computer if he so wishes and take over control himself. He might do this in order to introduce his own preference into its progressive movement or alternatively because he senses that the computer is failing to take account of some variable or phenomenon which is threatening to place it and himself into a potentially dangerous situation. A situation which it was not anticipated would occur and which consequently was not programmed into the computer. At times he may be forced to take over due to some system malfunction and from time to time he may take over in order to practice and maintain his control skill. In the novel situation the human operator uses his superior perception to evaluate what he senses in order to establish meaning and to translate significance into action. At times of malfunction he uses his adaptive control skill to counteract fault conditions and changes in the vehicle characteristics. Recently, for example, an airliner whose engine failed to extinguish when fire broke out caused the aircraft to lose a substantial part of its starboard wing and control surface. Somehow as the crisis built up the pilot managed to develop a control strategy that was effective. The aircraft was brought into land without loss of life and without further damage. By the time the aircraft was successfully landed its dynamic characteristics and therefore control characteristics were radically altered from normal. The pilot had progressively compensated for these changes and adapted rapidly but in so doing he was forced to sacrifice all concern for

passenger comfort in his struggle for survival. At this time much of the research effort devoted to studies of man as a controller is seeking to establish the nature, the basis and the limits to the rate of human adaptation. Young (1969) provided an excellent account of our knowledge on this aspect of manual control, as he saw it in 1969. From the safety angle it is important that one know under what conditions the human operator can and cannot cope in order that the last 'line of defence' be optimally allocated between man and machine. Ultimately and philosophically it is argued, man must be responsible for the machine that he has created so, even although it is now technically possible for a machine to exercise complete control over an aircraft or space vehicle, human judgement, whether it is right or wrong must prevail over that of a machine which has no fear of death. The counter to this argument is that occasionally it is only the speed of response of other machines such as the computer which can cope with the crisis so that the ultimate judgement for the human operator must be when to abandon manual control and commit himself and the destiny of others into the hands of the computer. The program for such a computer, when it is written will be a fast time simulation of human control and pattern recognition skills and will benefit from knowledge of control and survival strategy at the time. The need for such a last line of defence will depend upon our knowledge of how well man is able to cope with likely conditions and upon the likelihood of these conditions. One condition - vibration and the assessment of its effect upon task difficulty is the subject of the second part of this thesis.

The method used to assess vibration was the Adaptive Task Technique claimed to be a more sensitive and reliable than non adaptive alternatives.

In the first of two reviews, in Part II, the historical, technical and intellectual development of the technique has been traced and the evidence of its relative advantages examined. The second review is devoted to an examination of research evidence on the effect of vibration on manual control capability. As part of this review the nature of Control Skill has been described and the positive and negative effects of vibration associated with it identified. The vibration review has concentrated on an examination of what were judged to be the most realistic tasks and studies but the review does not include an examination of the more fundamental effects of vibration on vision, manual dexterity, the component processes of skill or higher mental capacities. Such fundamental effects that occur are however an integral part of the more general findings associated with the overall control task.

As part of the research reported in this submission four experiments were conducted two of which are reported in full detail and a third has been used to exemplify the development of a control strategy. One experiment involving a non-adaptive control task has been omitted. This experiment, it was intended, should represent the "classical" research technique as a basis for appraisal of the adaptive task technique. The experiment was carried out and results obtained but analysis difficulties prevented comparisons from being made.

All three experiments which involved the adaptive technique used a task developed in 1966 by Systems Technology Inc. for N.A.S.A.. The task developed was termed a "Critical Tracking Task" and was used by N.A.S.A. to assess the upper limits to manual control capability imposed by prolonged weightlessness, the wearing of space suits and a galaxy of

other physical and environmental impediments. For the experiments reported in Part II the task was further developed into an adaptive form but the results remain in a form directly comparable with the Systems Technology / N.A.S.A. findings. An account of its development and background theory are given together with the learning and briefing requirements which were found necessary.

Three types of vibration were studied in order to compare their effects on task difficulty. They included non-stationary as well as stationary random vibration and sinusoidal vibration. Subjects for the first experiment were carefully chosen to represent the full range of manual control skill so that at one extreme there was a lady claiming to be devoid of any such skill and at the other Test pilots. This range of individual difference was deliberately introduced in order to test the claim that "the adaptive technique is capable of separating a far greater range of individual difference in skill than non-adaptive fixed task techniques".

Part I has nothing or everything to do with Human Factors depending upon how you look at it. It contains a fundamental re-examination of concepts of waveform analysis - an examination which was motivated by a perceived need for a formal structuring of the waveform description problem, a perception based upon many years of experience of Vibration, Noise and EEG data analysis. Fundamental consideration has been given to the types of waveform, the possible dimensions and types of description, features and events which can occur within and between waveforms, occurrence relationships and descriptions of the patterns of occurrence which occur in the Temporal Structure. These broad categories are the

basis of the formal taxonomy presented.

Waveforms, it is reasoned, contain dimensions along which changes in the parent phenomenon can take place independent of changes along other dimensions. For this reason it is important to be able to detect changes in the occurrence of alternatives along each dimension, otherwise change in the phenomenon may go undetected and the waveforms declared no different. To this end a method of description has been devised which has the merit that it can detect changes along the frequency dimension independent of the amplitude dimension. The description is based upon an analysis of the Waveform Phase Plane Plot and has been implemented as a "black box" analog computer and programmed digitally.

Waveform Analyses carried out on the vibration and control task data resulting from the experiments, form the link between Parts I and II. Each waveform was committed to a battery of analyses including the novel Phase Plane technique by which means it was possible to validate the technique by comparison with features revealed by the other techniques. Analysis of the Human Operator control function was included but dissapointingly computing failures prevented the most appropriate analyses from being carried out.

The submission ends with an appraisal of the major experimental and analytical findings which are contrasted with the survey findings.



PART I

THE DESCRIPTION AND INTERPRETATION OF CONTINUOUS RANDOM VARIABLES  
(WAVEFORMS) IN NEUROPSYCHOLOGY AND ERGONOMICS RESEARCH

## 1.0. INTRODUCTION

### 1.1. Importance of Waveforms

Whatever significance waveforms may have for the man in the street, to the Neuropsychologist (brainwave specialist), the Vibration Engineer, the Communication Engineer, the Radio Astronomer, the Seismologist, the Geophysicist, the Ergonomist studying manual control and Biomechanics and a thousand other specialists their interpretation is their livelihood.

In science and technology where measurement and knowledge of measurement accuracy is the law of Epistemology the waveform provides a convenient means of graphing two measured quantities in two dimensional space. Most often, in this space, Cartesian co-ordinates are used where the state or quantity of the measured variable is the ordinate with time along the abscissa. Not all graphs in two dimensional space are waveforms, for example, the graphs on page (53 ) are not waveforms, even although two measured quantities have been plotted in Cartesian space. To be a waveform a graph must conform to the following rules :-

a) The Singularity rule - that for any value of the abscissa variable or at any point on the abscissa the ordinate variable must have one, and only one state including the zero state.

b) The Construction rule - that the graph be plotted in such a way that points in space which correspond to adjacent ordinate and abscissa pairs must be joined to each other by a curve or a line and to no other pair of co-ordinates not adjacent.

c) The Continuity rule - that to be a single waveform all adjacent co-ordinate pairs must be connected with either lines or curves (where curves are justified) to make up a continuous graph. Any graph plotted with

missing line segments must be regarded as two or more separate waveforms unless the co-ordinate values of the missing line segments are known or can, with justification, be interpolated to enable the missing waveform segment to be inserted.

Clearly, this definition excludes the phase plane plots from the class of graphs which have been defined as waveforms because of the singularity rule. However, the rule places no restriction on the order in which co-ordinate values must be plotted and thus allows it to be plotted starting at any point in the space. For example in Figures 5, 6 & 7 for reasons of economy of computer time, the top waveforms were plotted from left to right, the second row of waveforms from right to left and so on.

When the abscissa is time, the waveform, in the research context, is usually a time history record of a measured variable. Time is not, however, the exclusive variable plotted on the abscissa, others such as distance along a surface are equally valid, indeed the definition above places no restriction at all on the range of variables to be plotted. When the abscissa is time, because of the range of this variable, time history records tend to have a high aspect ratio between the length of ordinate compared to abscissa. If there is a population stereotype of the concept of a waveform it is probably of it as a long thin wavy line usually on a strip of paper.

In statistical terms waveforms are referred to as time series - time series because statistical sampling processes produce a series of values of some measured variate at discrete points in time. In addition and central to

the idea of waveform data reduction and statistical description, there are the processes of averaging which themselves produce a time series when short time averages are applied to long waveforms. A time series so constructed, so long as it conforms to the prescribed rules for a waveform, will be treated as such in this presentation.

There are, of course, other ways in which functions of time may be displayed and to some extent these other ways are the subject of this study. Time cycles are an example where the time function becomes a rotating vector, the length of which is made proportional to the measured quantity with time of day or week or month recorded as the angle. Some barometers and industrial thermometers produce a display of this kind. Such displays have the advantage that they are compact but tend to be confused and obscured if the trace becomes overwritten when the vector angle exceeds one cycle.

Some measure of the importance of waveforms may be derived from the fact that wherever one goes, in Science and Technology, and no matter what the research, people can always be found peering at waveforms on oscilloscopes, or long strips of paper or pointing to time series pinned on the wall. In Science and Technology waveforms are ubiquitous - they are in a sense the lowest common denominator of the raw results of research and final results and conclusions are often based upon comparisons between descriptions of them.

People who study waveforms do so for a variety of reasons and their interpretation depends upon their source as well as their form. When the waveform is the time history of a dependant variable the reasons for its study

may be classified as follows:

- a) Source identification.
- b) Identification of the underlying mechanism, process or system which produced it.
- c) To identify transmission pathways between the source and the point of measurement of the variable.
- d) To explore the characteristics of the waveforms in the search for signifying relationships between the dependant waveform and the independant variables or other measures of state and to do so for reasons of -
  - i classification or diagnosis
  - ii description
  - iii prediction.
- e) To establish similarities or differences between the results of experiments and to conclude on the basis of these comparisons.
- f) To study/describe the dynamic characteristics or changes in state of the variable in terms of dynamic range, frequency of occurrence and rate of change; with perhaps the objective of classifying the variable in order to compare it with others.
- g) To interpret the meanings of the waveform given knowledge of its source and the mechanism or process which produced it, where the measurements were made, how they were made, the conditions under which they were made and most important, the reason why the measurement was made with a statement of the hypothesis, if any, to be tested by the measurements.

If the waveform is an independant variable it is likely to be a candidate in a cause and effect situation. To know the nature of this cause is the reason why it is studied. If the independant variable is controllable it is likely that the experimenter will want to know that it has desirable characteristics.

It was said that waveforms are studied for different reasons and the major reasons have been specified. Radio astronomy and vehicle vibration provide an example where it is the source that is of interest. In manual control research and in communication engineering and the majority of physical sciences the waveforms in electrical form provides the fundamental means by which mechanism and processes are studied. In brain research the mechanism underlying the brainwave remains unsatisfactorily identified. The determination of noise and vibration pathways are an example of the third reason and neuropsychology of the fourth. The study of force and acceleration waveforms applied to the human body in a variety of situations and tolerance to them is an example where it is important to study the dynamic characteristics of the waveform. Studies of metal fatigue are another example and most experimental research and measurements made under operational conditions fall into the last category of reason but as a specific example consider a time series of absenteeism in a personnel system. Here the waveform, if it is recurrent may mean that a variety of actions need to be taken on a systematic basis such as the scheduling of work.

## 1.2 The Value of Waveforms

Whatever reason people may have for studying waveforms it is possible, almost without exception, to increase their value by some form of machine analysis or description. In addition to the information which can be obtained by visual inspection, further information can be obtained through a variety of computational schemes which are capable of revealing characteristics of a waveform which are neither visible, perceptible nor obtainable by any immediate mental processing of the visible waveform. These invisible characteristics concern the frequency on circular dimension of the waveforms

and the internal structure of its alternatives. Consequently how people study waveforms is usually a combination of more or less human visual inspection and pattern recognition with machine analysis of one form or another. In the present state of the art the machine can perform certain descriptions very well and others not at all. Analysis and decisions easy to the brain the machine either cannot perform or can perform with difficulty usually taking a long time to do it. For exactly the same reason that no machine can yet compete with the brain when it comes to the recognition of signatures on cheques (I say this with some reservation because I have the feeling that Matthew Kabrisky may by now have succeeded in doing it) the machine cannot compete with the brain when it comes to the recognition of signatures in waveforms. Consequently in the study of waveforms of biological and human origin, such as the electroencephalogram, which are eventful compared to waveforms of physical origin and where signatures are sought, visual processing is the rule rather than the exception. It is, therefore, part of the purpose of this thesis to examine the capability and relative advantages between man and machine in the processing of waveform data in order to reconcile their combined capability with research needs or stated another way, with the reasons why waveforms are studied.

The value of a waveform in research, as elsewhere, depends upon the extent to which knowledge of it enables the research worker to succeed in whatever it is he is planning to do. At the simplest level this may require specific questions to be answered, for example as to the statistical nature of the measured variable, or it may involve the waveform as part of the planning process itself. Consequently the value of a waveform may be judged by the contribution that it makes to the achievement of goals or by the extent to

which it causes the research worker to succeed by modifying his goals.

In the current state of the art few research workers, if any at all, make the most of the waveforms that they acquire. Important information pertinent to all forms of success in research is often wasted due in part to the state of the art in waveform analysis and the difficulty that this imposes but more commonly because its source is not known to exist.

Another reason is that overpopularisation of certain analysis techniques and the technical 'straight jacket' that this has created has caused those familiar with the more comprehensive methods of description to inhibit their use for fear of having them rejected and misunderstood. Presently, in support of this claim, a concrete example will be given but now it must be said that failure to completely describe a waveform is the cause of a uniqueness problem. This problem exists when the same description can apply to different waveforms and is symptomatic of incomplete descriptions. The problem also exists if identical waveforms have different descriptions. This latter form of the problem sometimes exists in practice due to malfunction or insensitivity in the analysis but cannot occur in theory.

In a decision situation which involves the classification of waveforms it is fundamental that the quality of decision can be no better than the quality of classification and this in turn depends upon the quality and uniqueness of description. In research the advantages and indeed the scientific requirement to be exhaustive in description is well known, well understood and does not need justification here. However, to be exhaustive in practice is extremely difficult and sometimes impossible. Consequently not to be exhaustive is not always a sin but to settle for anything less is and is especially so in the preparatory stages of a system of classification.



In the treatment of brain disorder the importance of waveforms is well known. Here is an example where important decisions are made, not wholly, but in part, on the basis of waveform classification. Here also is an example where research could benefit from more complete description. In this field the task of the research worker is to discover, if he can, how the untidy patterns produced by the brain are related to known specific conditions both clinical and normal and how important independent variables affect them. It is a specialism which has progressed to the point where most, if not all, of the obvious relationships have been discovered and a lot not so obvious, and where further progress now depends upon the discovery of covert relationships which machine analysis alone can uncover.

In this and in other fields of research it is obvious that the research worker is more likely to succeed given a comprehensive system of description that avoids the uniqueness problem than one which admits it. The danger of incomplete description is that changes and differences all important to the research worker will go undetected if they occur along dimensions or within a structure which has no description. Where the waveform is displayed for visual inspection the problem is not so serious because the credence of any analysis can be checked against visible features of the waveform. Credability is, however, more difficult to establish where the measured variable is committed directly to machine analysis without going through the routine of visual inspection. This form of description becomes increasingly popular with the advent and proliferation of special waveform analysis computers and other hardware and serves to fortify the argument for complete description.

Two Waveforms having the same Power Spectrum.

Figure 1

Waveform

Spectrum

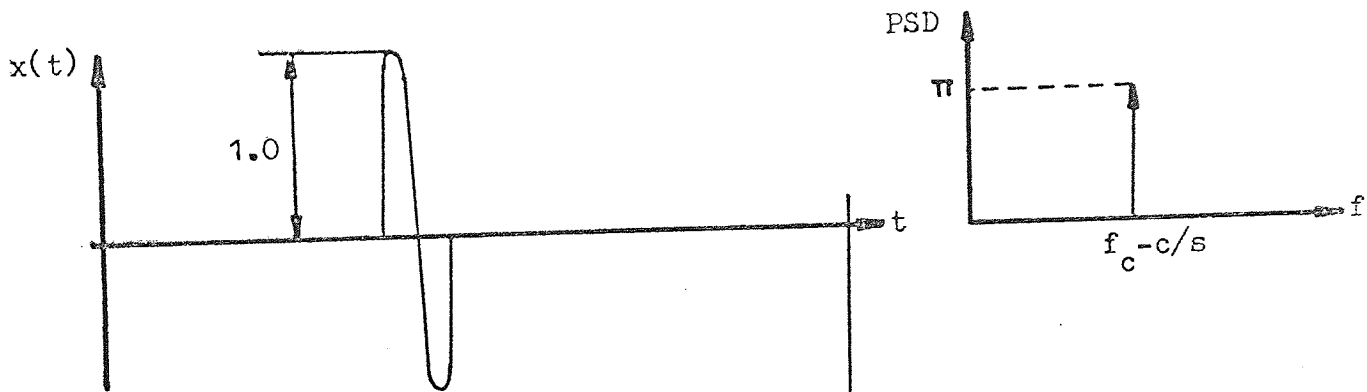

$$\text{PSD} = \frac{1}{BT} \int_0^T x^2(t, B, f_c) dt = \frac{1}{BT} \int_0^T A^2 \sin^2 2\pi f_c t dt$$

$$\int_0^{2\pi} \sin^2 x dx = \frac{x}{2} - \frac{1}{4} \sin 2x$$

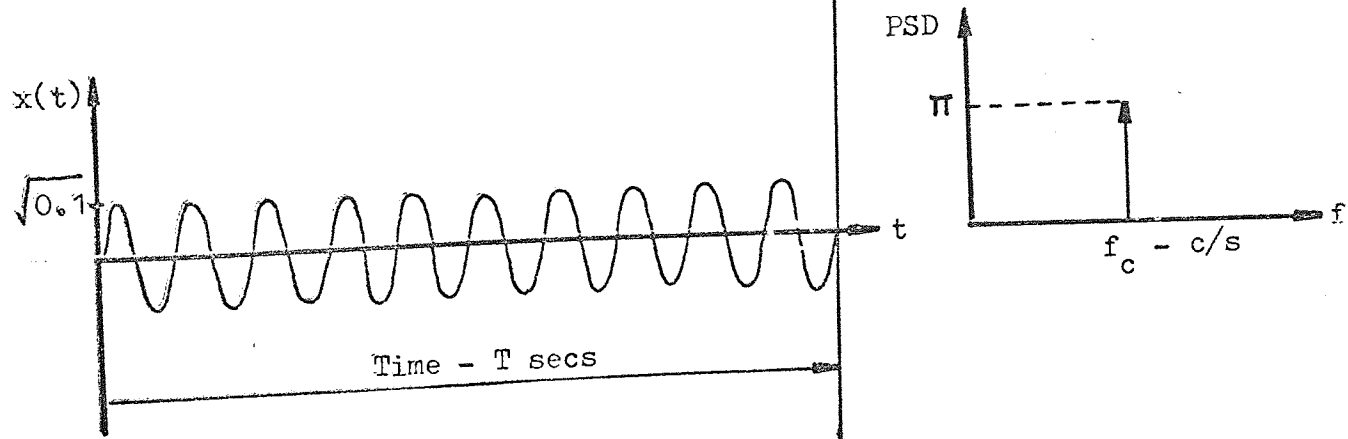

To further reinforce this argument and to return to the concrete example where important information is ignored, consider Power Spectral Density or Frequency Analysis, as it is more widely known. This is a statistical description which is very popular, very revealing and very often the sole description applied to a waveform. It is a description of the frequency make up of the mean square value taken over an interval  $T$  seconds of the waveform. Stated another way it describes, as a proportion of the length  $T$  of the waveform, the amount of time spent by the mean square value at each of its frequency constituents. In Figure 1 this description is shown applied to two entirely different waveforms with the same result. In both cases the mean square value spends all of its time at the same frequency and since each has the same mean square value, each has the same P.S.D. value. The conclusion to draw from this example is that the P.S.D. description does not reveal whether a P.S.D. value is caused by a little ripple along the whole length of the waveform, by a single high amplitude event at that frequency or by what combination between these extremes. The importance of information of this kind cannot be overstressed. Indeed knowledge of this kind may be vital to well being. If in Figure 1 the waveforms were measures of force, to which it was proposed to expose a human subject, the difference could mean a difference between well being and serious injury. In the case of metals the applied force with the high amplitude may exceed the elastic limit. There are numerous more examples where the consequences of such ignorance could be serious and an even larger number such as brainwaves, where the single description has no serious consequence other than ignorance. The important point is that for the reasons given, it is a serious deficiency of description to apply P.S.D. analysis alone to a waveform. Where both amplitude and frequency are important an amplitude description must be given. Where this is the case it

is usual to find the P.S.D. description accompanied by an Amplitude Occurrence description specifying the amount of time spent by the waveform at each point in its range of amplitude expressed as a proportion of the waveform length T seconds. Where it is important to describe both amplitude and frequency, in order to identify change or for reasons of sensitivity to each characteristic, one might suspect that it is equally important, for the same reasons, to describe how they occur jointly. To use the same example, both people and metal can tolerate high physical forces for a short period of time, but the duration of tolerance is dependent upon the frequency at which the force is applied. At their most sensitive frequency, both fatigue very rapidly when the amplitude is high. Waveform descriptions which reveal at what frequencies the amplitudes occur and for how long they are sustained exist in theory but are generally unknown and entirely unused. This last statement is intended to be cogent. It is based upon some 10 years of experience of waveform analysis in the disparate fields of research quoted and it is an invitation to anyone who has knowledge that such descriptions have been used to let the author know.

The description of joint occurrence between amplitude and frequency suffers from the combined problem that it is technically difficult, time consuming and presents some conceptual difficulty to waveform specialists as well as non-specialists. The technical problem derives from the difficulty associated with the separation of amplitude from frequency and the conceptual difficulty from the nature of frequency. In the text to follow some discussion is devoted to the latter and a practical solution is offered to the former in the form of an analysis of the phase plane plot of the waveform. The main aim, is, however, to review existing methods of waveform description to elucidate precisely what features each reveals, to indicate how and by what

means complete description may be achieved for each class of waveform and to progress where possible the knowledge of techniques. These and other specific aims together with a summary of the motivating forces are listed below.

### 1.3 Summary of Aims

As the title to this first part suggests this is a study devoted to the treatment and interpretation of waveforms which result from measurements made in Human Factors Research in particular and Biological Science in general. The study is intended to be comprehensive in its coverage of objectives as they occur in these research areas at least to the extent that the special requirements of each objective in terms of data, techniques and statistics are specified. There is, however, a propensity towards the study of transfer properties, the discovery of relationships and the display requirements of the research worker who has to interpret their meaning. In fact, waveform analysis is seen as a combined man-machine operation and a systems approach is adopted which examines the allocation of function between research worker and machine in terms of relative advantages and other criteria which permit an appraisal to be made of the current and possible future role of the human and non-human means to the ends.

The specific aims are as follows:-

#### Review

1. To review classical methods of waveform description and systems of classification.
2. To elucidate precisely what features each reveals.
3. To examine the relative advantages between alternative descriptions where they exist.

4. To give some impression of the state of the art of waveform analysis in terms of currently available hardware.

#### The Uniqueness Problem

5. To indicate how and by what means complete description may be achieved for each class of waveform.

#### Biological Signals

6. To examine the mathematical philosophy of waveform analysis theory and to comment upon its compatibility with the needs of biological research.

7. To examine the nature of biological signals and to comment upon the compatibility between their nature and classical methods of waveform description.

#### Systems Analysis and Human Performance

8. To examine the range of objectives associated with waveform studies.

9. For each objective to study the role of the human operator with respect to its achievement, the aim being to provide guidelines for more meaningful research in this area.

10. To examine the display requirement of the research worker who has to interpret waveforms and the results of analysis.

#### 1.4 Motivation

This study is not associated with any concrete problem or practical need. Rather it was motivated by the perception that current practice in waveform analysis is both wasteful of information and incomplete in its description and that this, particularly in the discovery of relationships, is tantamount to a uniqueness problem needworthy of some research. The study was also motivated by the perception that existing expositions on the subject ignore human capability and do not cater for biological waveforms,

which tend to be eventful, non-stationary and highly non-linear in relation to each other compared to waveforms of physical origin. The reasons for the study are therefore academic rather than pragmatic but many of the results it is hoped will be of practical value.

## 2. THE TREATMENT OF WAVEFORMS

### 2.1 The Role of Waveforms in Human Factors and Biomedical Research

The role of waveforms in these research areas is really no different from their role elsewhere in research. In whatever form they exist they are a record - an expression of the real world by analogy. They constitute a means of communicating and studying what has happened to measured variables in the course of time covered by the record. As scientific information they are a posteriori or quantitative in concept but they have a structure which may be regarded as a priori since it is known to exist before measurement.

These ideas on prior and posterior information were derived from McKay (1950) whose classic study of the "Quantal Aspects of Scientific Information" will be used to provide some of the terminology and basic formatism in this study.

The structure of a waveform is stated in terms of elementary patterns of occurrence of the waveform alternatives, which make up the overall patterns portrayed in the waveform itself. Knowledge of these elementary patterns of occurrence enable elementary propositions to be made about what has occurred and permit occurrence relationships to be established within the waveform.

These occurrence relationships and, more important, occurrence relationships between the internal structure and other information relevant to the research context permit a wider interpretation. Whether the waveform is a dependant or independent variable it is unlikely to exist in isolation. Waveforms usually exist alongside other information which may or may not be



in waveform and which may conform to any or all of the known measurement scales, i.e. nominal, ordinal, interval and ratio. Occurrence relationships, if and when they can be shown to exist, provide a means by which the research worker is able to differentiate between results, to classify them, to detect change, to quantify these observations and to establish meaning both as structure and signification. (The terms: meaning as structure and signification have been adopted from Garner (1962)).

In another sense, particularly in laboratory experiments, the waveform may be used to generate standard experimental conditions or to simulate real conditions. This role is well known. To do it, however, requires stable and high fidelity reproduction and control apparatus and it is important to know what will occur. At one extreme the requirement may be to reproduce in precise detail the original waveform. At the other extreme it may be necessary to reproduce or simulate a single elementary pattern of occurrence characteristic of some representative population of waveforms.

In all of its roles, except that when it is purely a record, there is a need to know what has occurred in terms of elementary patterns within the waveform and between other relevant information. Indeed the more that is known about the internal structure of the waveform, the more it will help the research worker to differentiate, classify and to assign meaning to his results. It is therefore a major objective of this study to examine what can occur in a waveform, what elementary patterns exist and how they may be described by the use of existing theory and by more novel methods, not forgetting the unique capability of human visual pattern recognition.

As a research technique the study of waveforms must incorporate adequate consideration in the experimental design phase to ensure

- a) that the length of record is compatible with the confidence with which it is desired to make statements of occurrence.
- b) That it is within the equipment capability to describe the patterns of occurrence most appropriate to the research hypotheses.
- c) That the size of the data processing task may be appreciated and this matched to the concomitant time and cost objectives.

In courses which cover research techniques in the human factor field, the explicit study of waveform techniques tends to be a neglected topic. For this reason and because the author attaches much importance to the above considerations a subsequent chapter is devoted to the consideration of waveform planning matters, and how these might occupy a place in the normal procedures of experimental design.

3. WAVEFORM ALTERNATIVES AND QUANTIFICATION (WHAT CAN OCCUR IN A WAVEFORM )

It is fundamental that a single measured variable (which is the source of the waveform) is restricted to translation in magnitude and rates of change thereof, i.e. relative to some origin it can only increase and decrease with varying velocity, acceleration and jerk. Derivatives higher than the third are quite possible but have no analogy in the dynamic world. This translational mode of variation constitutes just one degree of freedom. In dynamic terms there are no other degrees of freedom but it has become proper to a waveform to regard frequency as such because of the importance of Fourier Transformation. Frequency is a pseudo rotational degree of freedom. The sense in which it is pseudo will be elaborated shortly.

In this presentation the magnitude of translation from the waveform origin will be referred to as AMPLITUDE of the waveform. The position of the origin on the waveform ordinate will depend upon the quantity measured, but where possible there will be a translation of origin to the amplitude mean value, viz:

AMPLITUDE MEAN VALUE       $\bar{x} = \frac{1}{T} \int_0^T x(t) dt$  ————— (1)

Where T is the length of the waveform in seconds, x the amplitude and t the time at which amplitude occurs.

Seemingly, a variable whose amplitude changes continuously in some finite range can have an infinite number of alternative states if its scale can be

Principle for the Quantification of Slope.

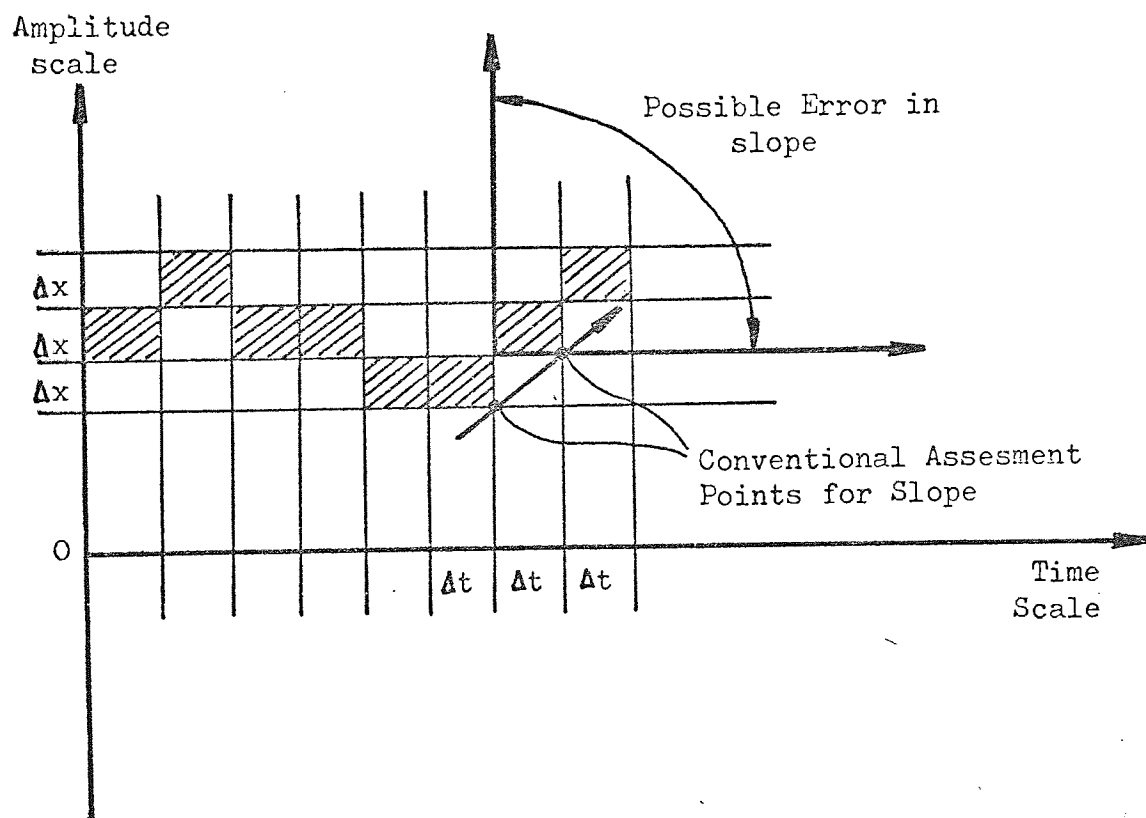

Note: that shaded areas indicate the region of space occupied by the waveform in the course of time

divided into infinitesimally small intervals of amplitude. This of course is not possible because measurement accuracy places a restriction upon the certainty with which we are able to locate a point on a scale. The fineness of graduation, as a result, is restricted to an interval below which we either cannot define or cannot substantiate with probability greater than one half a proposition of the form  $x$  falls into the range  $x - \Delta x$  and not  $x + \Delta x$ . This latter axiom is due to McKay (1950) who also proposed that the smallest meaningful interval,  $\Delta x$ , be referred to as a scale unit.

There is, of course, a scale for amplitude and one each for its derivatives and each has its own scale unit. Immediately it is seen that the number of waveform alternatives in translation is just the ratio of the length of scale to scale unit summed across the number of scales, viz:

$$\begin{array}{l} \text{NUMBER OF} \\ \text{ALTERNATIVES} \\ \text{ASSOCIATED} \\ \text{WITH AMPLITUDE} \end{array} = x_0 / \Delta x + \dot{x}_0 / \Delta \dot{x} + \ddot{x}_0 / \Delta \ddot{x} + \dots + x_0^{(n)} / \Delta x^{(n)} \quad (2)$$

Where  $\Delta x$ ,  $\Delta \dot{x}$ ,  $\Delta \ddot{x}$  -----  $\Delta x^{(n)}$  are respectively the scale units for amplitude, velocity, acceleration and the nth derivative of amplitude and where the  $x_0^{(n)}$ 's are the dynamic range or scale length associated with each mode of translation. Equation 2 makes what is not always a valid assumption, that scale unit is constant for every position on the scale. In practice, where equipment has a limited dynamic range, a rapid change in the size of scale unit can be expected at the extremes of this range. More will be said on this matter in the chapter which deals

with problems of accuracy.

In terms of scale unit the quantity or magnitude of the variable which exists at any instant of time is specified by the number of scale units which it is known to occupy. This knowledge of occupation determines the metron content of the waveform at that instant of time. A metron is the knowledge which makes it possible to represent a scale unit interval of the scale as occupied, McKay (1950).

### 3.1 Time Translation

Implicit in most of what has been said in this chapter is the adoption of time as the variable on the abscissa. Indeed, unless otherwise stated, this will be so for the remainder of the presentation. Since it is an independent variable, time cannot constitute a degree of freedom but all that has been said about minimum meaningful interval - scale units, applies equally to the scale of time. The existence of a time scale unit places a restriction upon the number of independent measures of amplitude which may be made per unit of time. This number is given by the equation:

$$N = 1/\Delta t. \text{ per second } \text{-----} (3)$$

Where  $\Delta t$  is the time scale unit. In practice the time scale unit varies with position on the time scale but generally less so than on other scales.

In the quantification of derivatives the scale units of amplitude and time combine to produce a scale unit for the first and subsequent derivatives. In the Cartesian space of amplitude and time the first derivative is given by the angle which is subtended between the areas occupied by adjacent minimum scale intervals. In Figure 2 it is shown that this scale unit may be as much as  $90^\circ$  if it is not minimised by the adoption of conventional

Waveforms which are the Sum of Sine Waves.

Figure 3

Amplitude &  
Phase Spectrum

Waveform

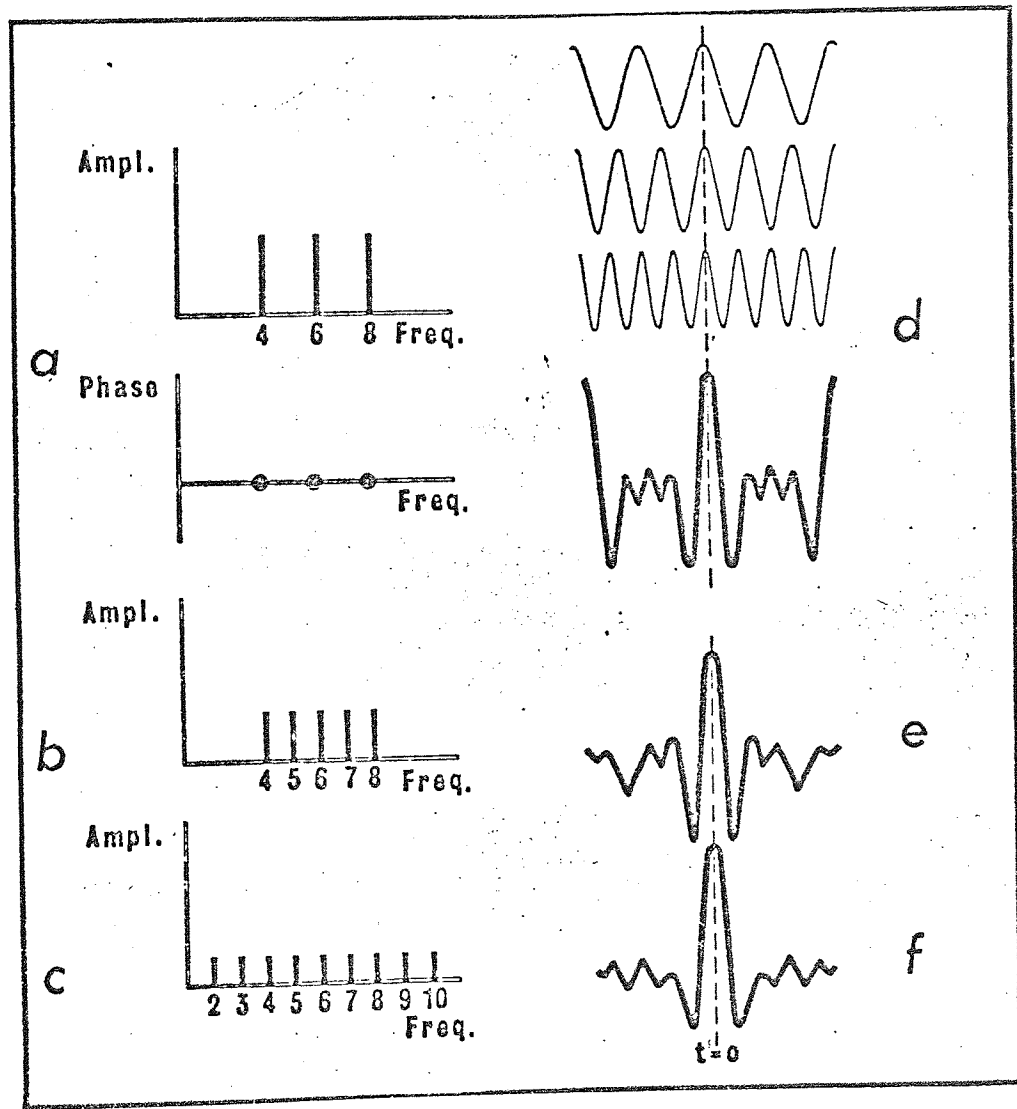

assessment points. The same argument applies to the second and higher derivatives.

### 3.2 The Nature of Frequency

Unlike amplitude and its derivatives, frequency is not a quantity which is explicit in a waveform. It is an angular velocity measured in units of radians or cycles per second (Hertz) but it is not related in any simple way to the curvature of a waveform which is visible in Cartesian space. It is a physical concept which is derived from a vector rotating in Cartesian space. If this vector is of fixed length and rotating with an eternal uniform angular velocity the projection of the tip of the vector on one or other of the orthogonal co-ordinates when converted into a waveform produces a sine wave or waveform of discrete frequency. This well known pattern of occurrence provides the template which is used both by the brain and by the process of Fourier Transformation to determine which frequencies are present in a waveform. The difference between these two is that the brain is very limited in its capability and makes mistakes in its judgement of the frequency content of a waveform whereas the latter does not. Some measure of this limitation can be deduced from Figure 3, which was taken from Anstry (1966). With or without a mental template of sine wave, and even with a considerable knowledge of sine wave combinations it is impossible to say by visual inspection that the waveforms on the right of the figure are the sum of the sine waves whose frequency and amplitude are depicted on the left of the figure.

In physical systems, and indeed in Biomechanics, as we shall see in Part II, frequency is important because of the resonance phenomenon and because of other system sensitivities whose existence may be expressed conveniently and



accurately in terms of frequency. The speed of response of a system is an example of the latter.

At any instant of time (which conforms to the uncertainty principle of the time scale unit) because of the way it is defined, a single value of amplitude may subsume any number of angular velocities (frequencies) in the discrete sense or any range in the continuous sense dependent upon the nature of the waveform. More than this, each rotating vector corresponding to each angular velocity will have its own angle as well as its own modulus (for the case of a range of frequencies present in a waveform the centre frequency of a small frequency interval can approximate to the rotating vector). Frequency is thus an extract or an expansion of a waveform. It is not a visible property of a waveform and it requires a stretch of the imagination to relate it to what is happening to the measured variable in reality. Its concept requires the research worker to imagine that the changes he observes in the magnitude of his variable are the additive result of a continuum of vectors on oscillators rotating with different angles between them. Since this is more than most practical minds can stand it is probably best to think of frequency not in any real terms, but as an abstract transformation which may or may not be relevant to a particular research context. At this juncture it is perhaps timely to remind ourselves that frequency is not alone in having the property to possess multiple values at a single instant of time. Amplitude too, in theory, can have any number of derivatives at any instant, it is perhaps also worthwhile to mention that because of the way it is defined and because of this multi-valued property, it is not sensible to think about derivatives of frequency. Probably the most important property of frequency (outside of its physical importance) is that it is orthogonal with respect to

amplitude, a property which it shares with the derivatives of amplitude. As such it is an independent dimension of description or an internal degree of freedom of a waveform, but not a degree of freedom in the sense which requires separate measurement of a variable.

These are two methods which may be used to detect frequency as it has been defined. They are Fourier Transformation and Frequency Filtration. Fourier Transformation uses the sine wave as a template to calculate a product movement correlation coefficient as a measure of the relatedness to a waveform. Frequency Filtration exposes the waveform to a frequency sensitive device. The response of the device to the waveform is taken as evidence that a range of angular velocities exist in the waveform the range defined by the spectrum of sensitivity of the device. This operation may be symbolised as follows:

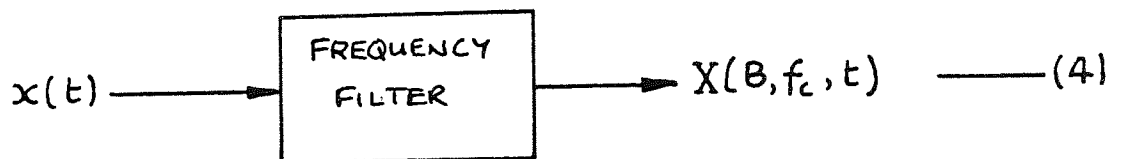

where  $x$  is the amplitude of the waveform at time  $t$  and  $X(B, f_c, t)$  the response of the Frequency Filter to the applied amplitude  $x$  at time  $t$ .  $B$  is the spectrum of sensitivity or frequency bandwidth of the filter and  $f_c$  the centre frequency of this bandwidth. In the limit as  $B$  approaches zero it is easy to imagine that the response of the device is an amplitude modulated sine, i.e.

$$\text{IN LIM.} \quad X(B, f_c, t) = X \sin(2\pi f_c t) \quad \text{--- (5)}$$

$B \longrightarrow 0$

The Vector Principle in Fouier Frequency Detection.

Figure 4

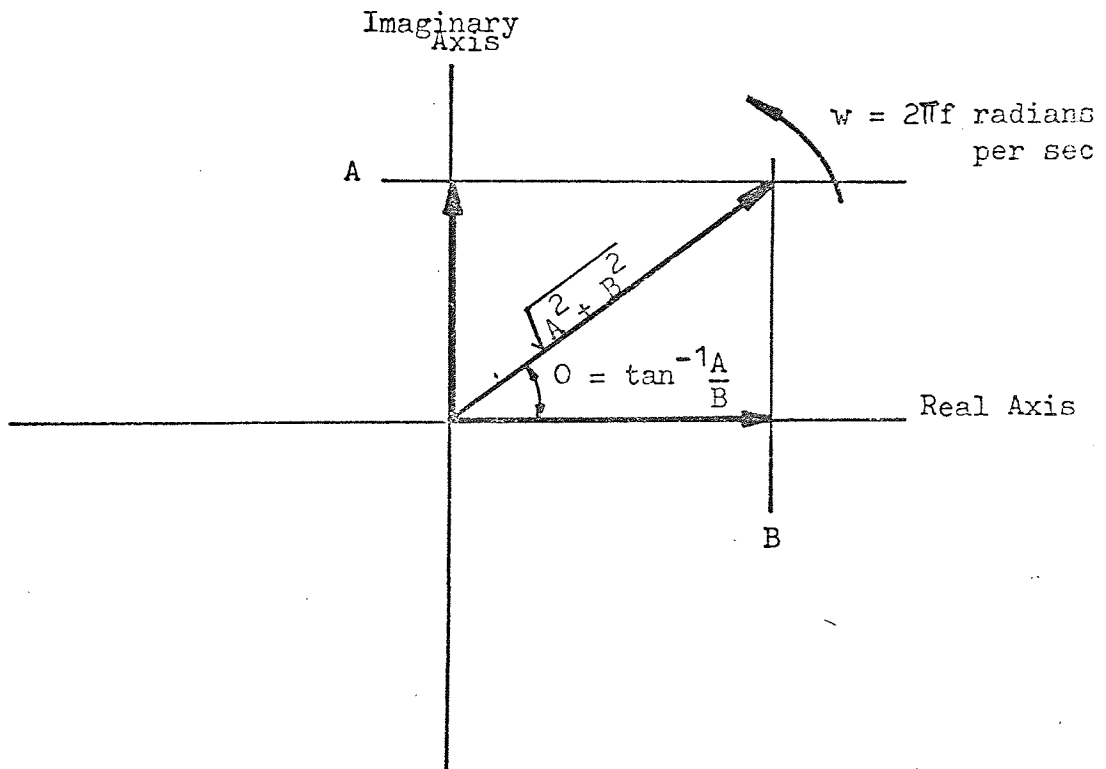

The Fourier coefficient is defined for the waveform as a whole and not for the waveform at any instant of time. Symbolically:

$$\text{FOURIER COEFFICIENT } F(f_c) = \left\{ \underbrace{\left[ \frac{1}{T} \int_0^T x(t) \sin(2\pi f_c t) dt \right]^2}_A + \underbrace{\left[ \frac{1}{T} \int_0^T x(t) \cos(2\pi f_c t) dt \right]^2}_B \right\}^{1/2} \quad (6)$$

This coefficient defines the average length of the vector which exists in the waveform at frequency  $f_c$  ds. The terms A and B compare the same sine wave with the waveform  $x(t)$ , except that in A the sine wave has been displaced relative to B by one quarter cycle or  $\frac{1}{4}f_c$  seconds. This displacement of  $90^\circ$  makes it possible to draw the vector graphically. Term B is called the real part of the coefficient and is plotted on the abscissa. Term A is the imaginary part plotted on the ordinate and the vector is simply their resultant of length  $(A^2 + B^2)^{1/2}$  and angle  $\text{TAN}^{-1} A/B$ . This is shown sketched in Figure 4. The Fourier method of frequency detection as it has been described, is most applicable to waveforms which are known to be the sum or superposition of sine waves or where it can be assumed, with justification, that this is so. Waveforms which do not conform to the superposition specification, and they are the majority, are not banned from the Fourier methods of detection. What the Fourier method fails to detect are any changes in the length of the vector in Figure 4 and any changes in its angle. If the waveform is a random waveform both length of vector and its angle are liable to change in a random manner. The former over a wide dynamic range. In this respect it is relevant that most waveforms of biological origin conform to this random class (a more rigorous definition of randomness is given in Chapter 4). It is important to note that when the vector exists, its mere existence is sufficient condition to freeze its angle. Only when the vector disappears and reappears can its angle change

to a new value. The failure of the Fourier technique to detect these changes is due to the averaging process in the calculation of its real and imaginary coefficients. The use of short time averages partly overcomes this insensitivity but the lowest frequency of interest, in the waveform, does not, in general allow this to be less than its reciprocal. If the averaging time defined in this way continues to eclipse vectorial variations a further modification to the Fourier technique is to compute the Fourier coefficient as a series of short time averages with averaging time related to frequency, i.e.

SHORT TIME  
AVERAGED  
FOURIER  
COEFFICIENT

$$F_S(f_c) = \left\{ \left[ f_c \int_0^{1/f_c} x(t) \sin(2\pi f_c t) dt \right]^2 + \left[ f_c \int_0^{1/f_c} x(t) \cos(2\pi f_c t) dt \right]^2 \right\}^{1/2} \quad (7)$$

In this technique the averaging time is made equal to the cycle time for each rotating vector, i.e.  $1/f_c$  where  $f_c$  is the frequency of the sinusoidal template.

### 3.2.1 Instantaneous Frequency Spectrum

In general, the instantaneous frequency spectrum (IFS) can be detected only by frequency filtration. For the class of waveforms which are the sum of sine waves the Fourier Transform method may be used to define the IFS but it is a mistake to think that this method can do so for any other class of waveform. To repeat what has already been stated - the Fourier coefficient (equa 6), when it exists, defines a sine wave which is assumed to exist for the length of the waveform and to have constant peak amplitude. For anything other than a summed sine waveform the amplitude of this constant sine wave is unlikely to represent the amplitude which actually exists at that frequency at an instant of time in the waveform. That this is especially so

Fourier Analysis & Reconstruction of a Square Waveform showing the Fourier SINE, COSINE, & POWER SPECTRUM Coefficients

Figure 5

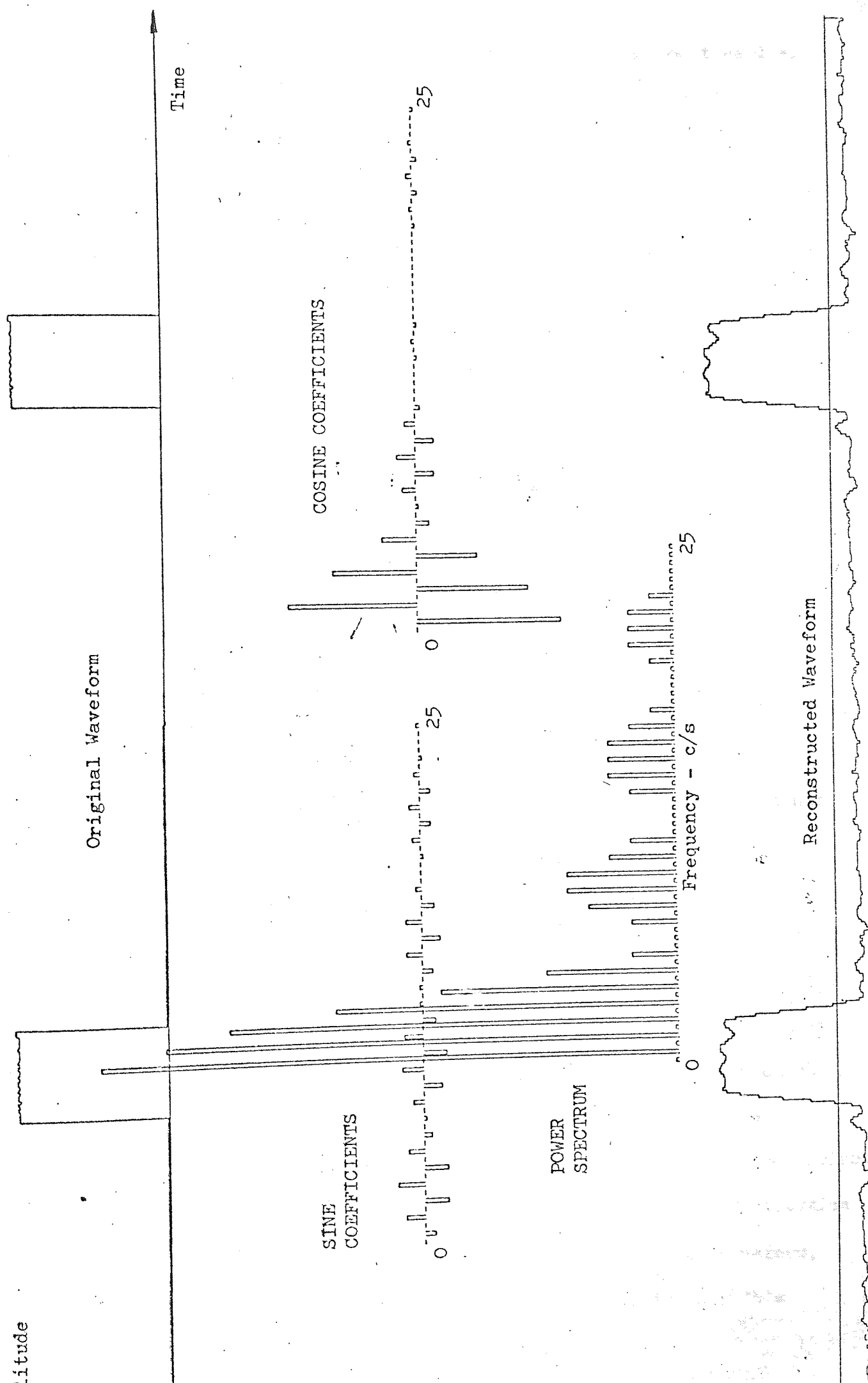

for the class of random waveforms is supported by the argument earlier concerning the random nature of the rotating vector and its angle.

Fourier coefficients obtained for random waveforms define the existence of a sine wave which is average both in terms of its amplitude and its phase angle. Some indication of the accuracy with which the Fourier coefficients describe the IFS of a waveform can be derived from an examination of its inverse transform. To do this the amplitude of the waveform is reconstructed at each instant of time by summing the amplitudes of the IFS which are calculated from the expression:

$$x(t) = \bar{x} + \sum_{n=1}^N (A_n \sin(2\pi f_n t) + B_n \cos(2\pi f_n t)) \quad \text{--- (8)}$$

$A_n$  and  $B_n$  in this expression are the real and imaginary parts of the vector in 6,  $\bar{x}$  the waveform mean value,  $n$  the harmonic number related to some fundamental frequency  $f$ , and  $N$  the extent of the frequency spectrum. An example where this has been done is shown in Figures 5, 6 and 7. In each case the waveform at the top is the original and the one at the bottom its reconstruction. The Fourier coefficients are in the centre with the real part on the right and the imaginary part on the left. The graph below the Fourier coefficients in Figures 5, 6 and 7 is the Power Spectrum of the waveform. The coefficients and the reconstruction were computed by the Fourier/Milner programme in Appendix which was slightly modified to perform this function. In each waveform there are 512 numbers to represent the original analog waveform. The reconstruction, which has the same number, is the sum of just 64 sine waves whose amplitude and initial phase angle are given by the real and imaginary amplitude coefficients shown in each of the figures and defined in equation 6. The reconstruction was according to equation 8 except that the mean value of each waveform, i.e.  $\bar{x}$  in (8) was subtracted out before Fourier transformation and this

Fourier Analysis & Reconstruction of a Frequency Modulated Sine Wave

Figure 6

Original Waveform

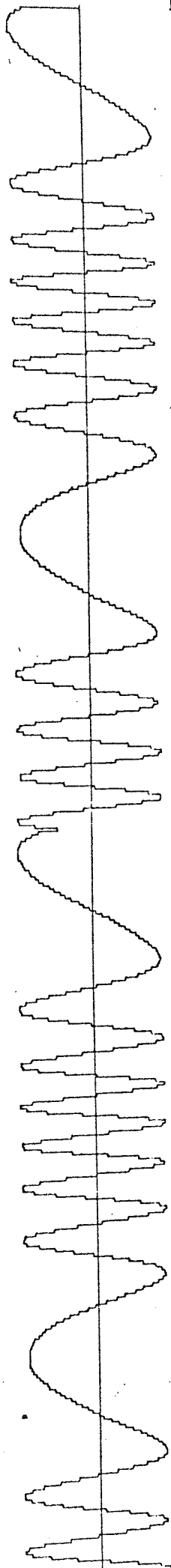

Fourier COSINE Coefficients

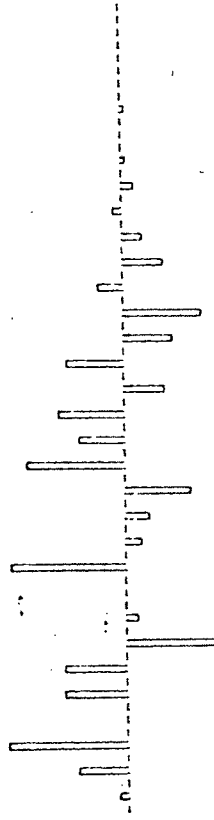

Fourier SINE Coefficients

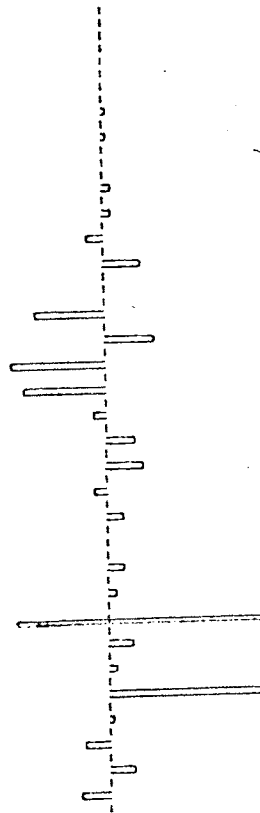

Reconstructed Waveform

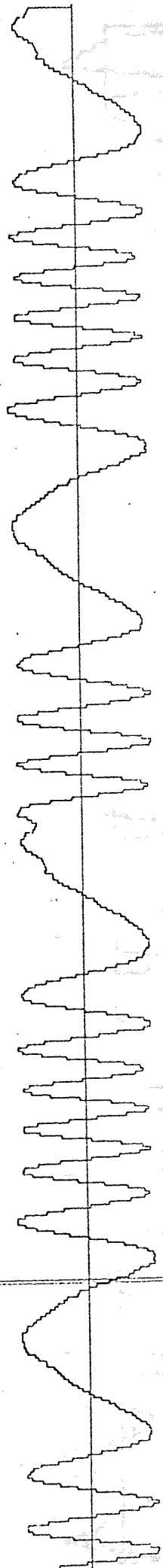



Fourier Analysis & Reconstruction of a 2.5 Second Sample of EEG Waveform.

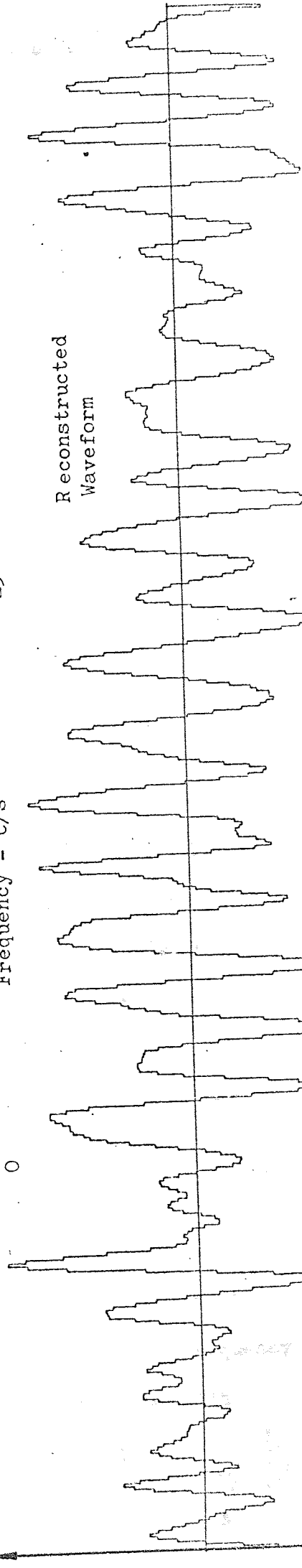
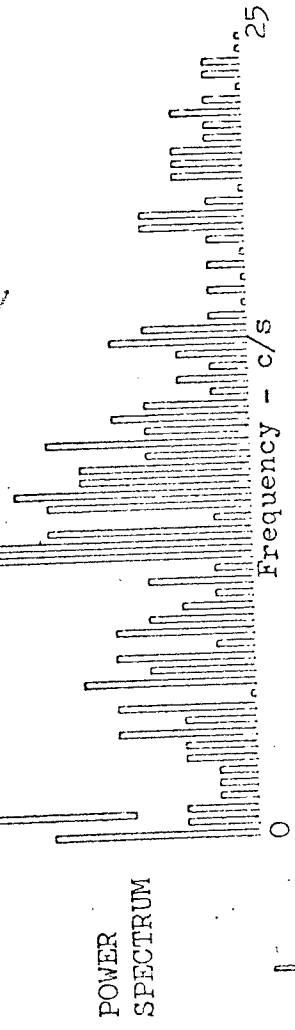
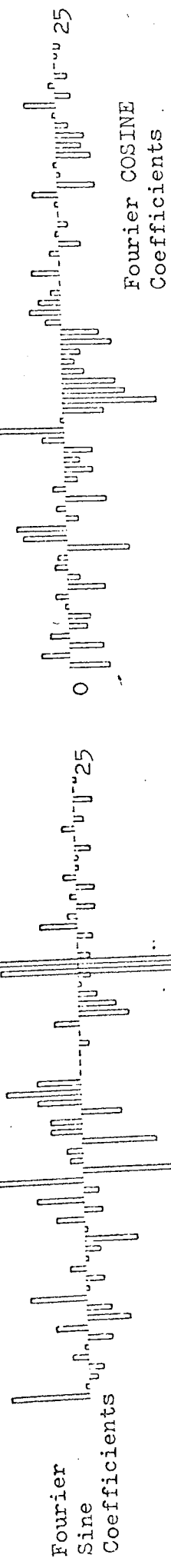
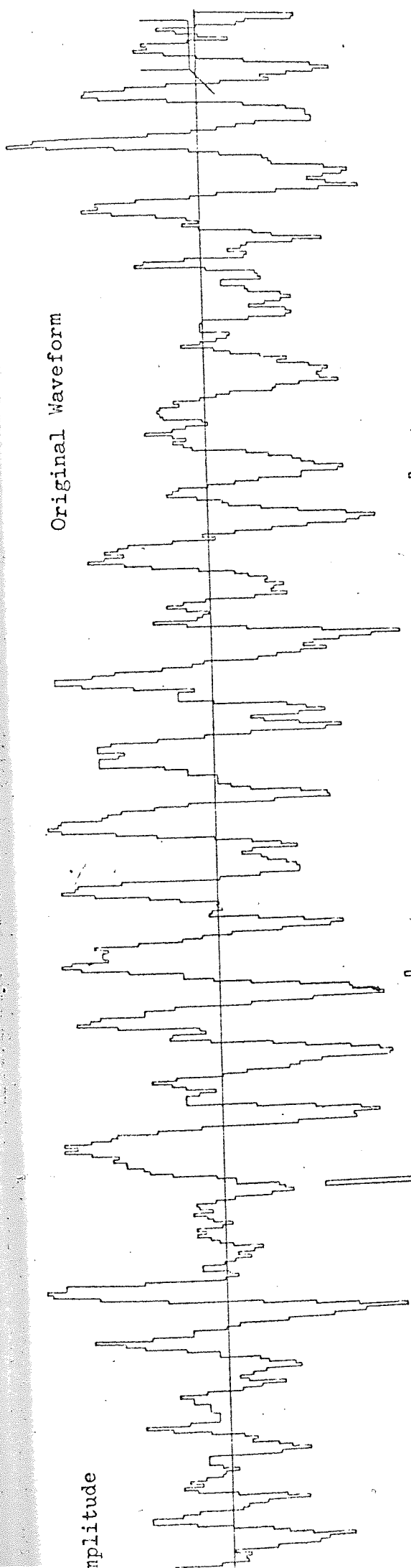

accounts for the shift in the reconstruction of the square wave in Figure 5, i.e. the mean value was not replaced during reconstruction.

The three waveforms were chosen to be as distinct as possible to demonstrate the comparative accuracy and versatility of Fourier frequency detection. In Figure 7 the random looking waveform is part of an electroencephalogram. The length of the waveform in real time is 2.5 seconds and the frequency analysis 0-25 c/s. From this it will be deduced that the major pattern of occurrence in the waveform conforms to that of the Alpha Rythm, which is confirmed by the power spectrum. The waveform in Figure 6 was contrived to show frequency modulation of a sine wave. The important thing to note is that in reconstructing the waveforms there is a loss of detail in each figure.

In each case it is certain that the major part of this loss is due to the approximation. It is, however, clear that the 64 sine waves are a better approximation to the random and modulated sine wave and the range of frequencies which they are likely to contain, than the square wave. The square wave, because of its vertical sides and sharp corners has an infinite range of frequencies (or none at all, dependent upon how you look at it). This is well known. Notice though that we not only have a loss of detail in the square wave reconstruction but an addition also which we do not have in the case of the random wave. In a sense it is hard to imagine that an arrangement of 64 sine waves can be made to approximate the square wave so well and the more so when one examines the mechanics of the transformation. To detect the occurrence of a frequency component in a waveform the Fourier technique compares a sine wave having the frequency of interest with the waveform. Two comparisons are made, the first with

An Illustration of the Joint Occurrence Relationship between High & Low Frequency Sine Waves & a Square Wave & between a Sine & a Random Wave Figure 8

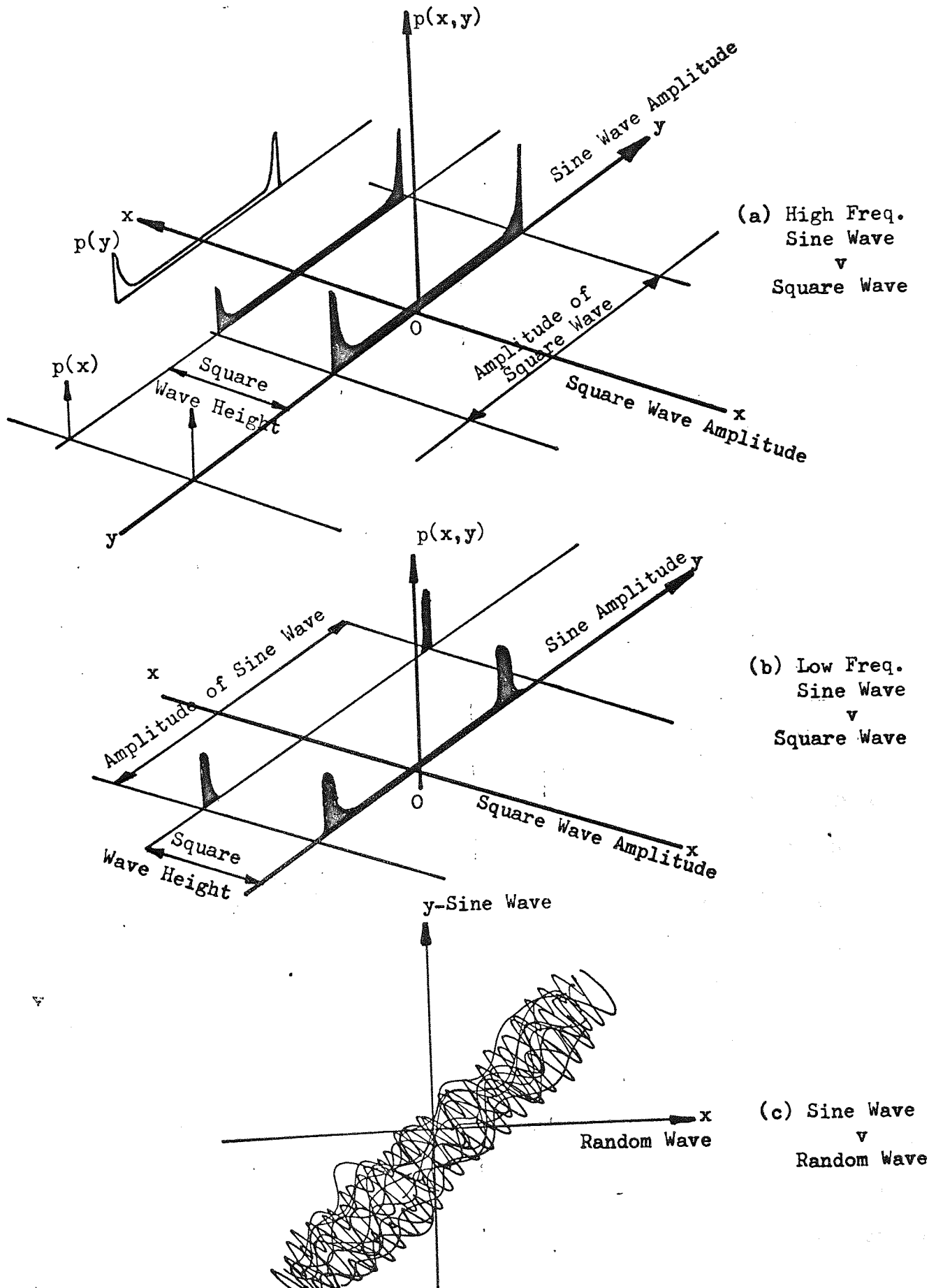

the waveform aligned so that its peak coincides with the beginning of the waveform and the second with the sine wave starting at zero. The agreement between template and waveform is determined by calculating a correlation index which is equivalent to the cross-correlation-numerator part of the product moment correlation coefficient. It is therefore a linear cross-correlation index and it assumes that both waveform and template have zero mean value (hence the need to translate the origin according to 1). To understand this measure of agreement it is better to think in terms of a scattergram where lines of regression and correlation have visible significance. To transfer thought to the scattergram we can translate the Fourier transform into the 1st product moment expression of a joint amplitude occurrence relationship between template and waveform, i.e.

$$\frac{1}{T} \int_0^T x(t)y(t) dt = \iint_{-\infty}^{+\infty} x.y.p(x,y) dx dy \text{ --- (9)}$$

where  $y = \text{Sin}(2\pi ft)$  and  $\text{Cos}(2\pi ft)$

An example where this has been done is given in Reference 2. page 67. In Figure 8 the joint occurrence relationship  $p(x,y)$  is shown plotted for the square and a sine wave of arbitrary frequency and below it the scattergram for the random waveform and the same sine wave. From an inspection of this diagram it is clear that the adoption of a linear regression line to describe the highly non-linear relationship which is apparent is a nonsense but the reconstruction in Figure 5 proves it to be a valid nonsense. In fact, if each sine wave does have zero mean value over the length of the waveform the regression line will be the x axis in Figure 8. Thus, since it is the 1st order product moment which is

taken to be the measure of goodness of fit of this straight line to the distribution only the marginal distributions for  $y$  at  $x = A$  enters into the calculation. (This is plainly obvious since no relationships exist outside  $x = A$ ). In terms of the amplitude occurrence relationship the Fourier coefficients are therefore:

$$\int_{-\infty}^{+\infty} Ay P(y/x=A) dy = A \int_{-\infty}^{+\infty} y \cdot P(y/x=A) dy \quad (10)$$

where  $P(y/x = A)$  is the amplitude occurrence distribution for a unit sine and cosine wave at  $x = A$ . This consideration of a "scattergram" has been a rather elaborate and perhaps cumbersome way to say that it is difficult to relate a sine wave to a square wave and that the method adopted in Fourier Transformation is thought to be responsible for the "noisy" reconstruction in Figure 5 .

To return now to the idea of an instantaneous frequency spectrum (IFS) it has been shown in Figures 5 , 6 and 7 that the amplitude of an arrangement of sine waves at any instant of time can be used to represent the amplitude of the waveform at that instant. This suggests that the amplitude of each of a set of sine waves may be thought of as an IFS. However, when this Fourier IFS is compared to one obtained at the same instant of time by frequency filtration the results are not equivalent. That this is so is to be expected because the methods of frequency detection are themselves in no way equivalent. The former is based upon cross correlation and the latter upon the response of a device which is sensitive to selected frequencies. The only sense in which they

are equivalent is that they each add up to the amplitude of the waveform at an instant. Unfortunately the author cannot comment upon the nature of this difference because no experiments equivalent to those in Figures 5 - 7 were performed to enable a comparison and there appears to be no mention of it in the available literature. It is clear, however, that whereas the normal Fourier Transform cannot detect precise changes over time in the frequency content of a waveform - because, it is an averaging process, the instantaneous response of a frequency filter can. For this reason alone the IFS detected by filtration seems intellectually to be a more realistic representation of the IFS than its Fourier counterpart. Yet another intellectual puzzle (to the author that is) is a third IFS which can be obtained from the instantaneous product inside the integrals of the Fourier transforms in equation 6. Where this stands in relation to the other two the author cannot imagine but intuitively it has no appeal as a candidate for the true IFS because it is impossible to establish a degree of relatedness based upon knowledge of a single occurrence.

In electing to adopt the IFS obtainable by frequency filtration as the true IFS it was not revealed that it too may be subject to an averaging process. As Bendat and Piersol (1966), page 358, have noted, if the bandwidth of the frequency sensitive device is very narrow, the device will not properly respond to the time trends in the frequency content of the waveform, since the narrow bandpass filtering operation is equivalent to taking a weighted average. To ensure that this does not happen it is sufficient to check that the filter rise time is less than the time period of the frequency whose time trend is highest.

To obtain an IFS of a waveform at an instant of time, the waveform must

Instantaneous Frequency Spectrum Analysis  
by Filtration

Figure 9

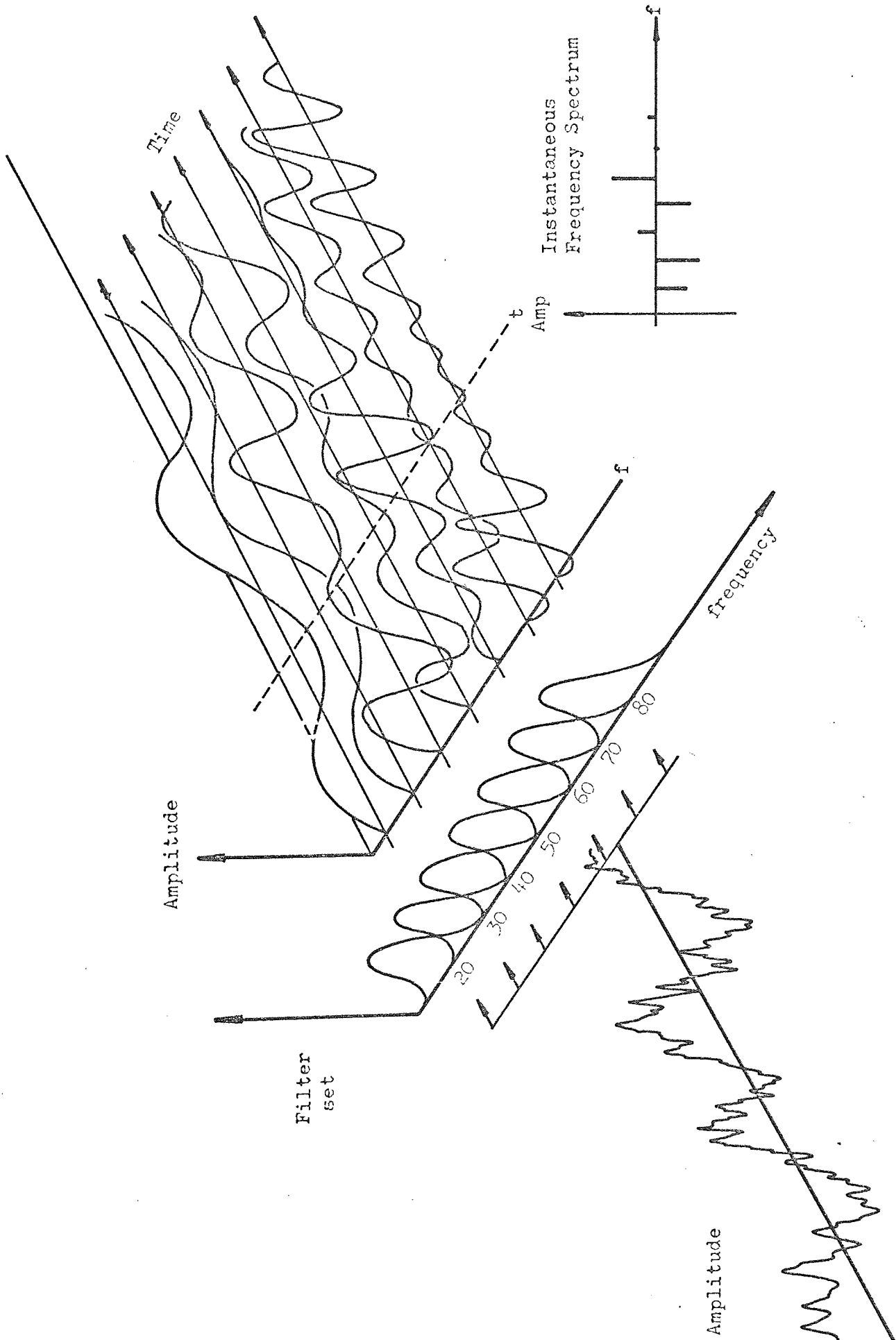

A Set of Contiguous Frequency Filters.

Figure 10

Note: The figure shows the Frequency Response of each of a pair of Filters having an Equivalent Noise Bandwidth of 10 Hz.

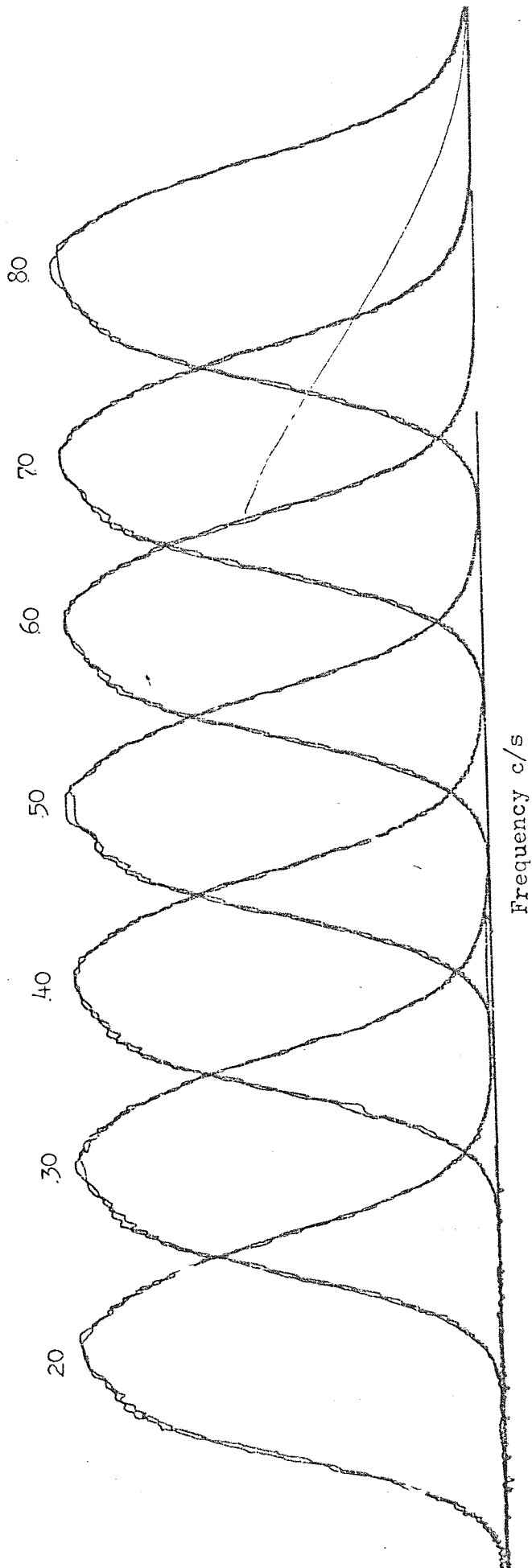



be applied simultaneously to a set of contiguous filters. After an interval has elapsed equal to the response time of the filter with the slowest response time, the IFS is the response amplitude of the filter set at each instant of time. To obtain an IFS with a single filter, a recording must be made for each pass of the waveform. The response of the filter for each setting of its centre frequency must be recorded so that subsequent reproduction or displays can be registered with the start of the waveform. An example showing the response of a contiguous filter set and an IFS is shown in Figure 9. The filter set used is shown in Figure 10.

### 3.2.2 The Separation of Frequency from Amplitude

Because of the way that frequency is detected in a waveform, both by filtration and by Fourier Transformation it is tacit that the occurrence specified is a joint one between translation and rotation, i.e. between the length and angular velocity of the rotating vector. It has been shown that filtration can specify the length of vector at any instant of time whereas Fourier/<sup>Transform</sup>really cannot. What is specified about angular velocity will be considered shortly under the heading Frequency Scale Unit. For the waveform as a whole, filtration answers the questions: At what amplitudes does the frequency occur? The Fourier Transform answers the question: What is the linear product moment coefficient between the waveform and a sine wave template? From this latter statement it is clear that the length of vector so defined by the Fourier Transform is not straight amplitude but a property of it.

It is equally clear that we can specify a purely translational occurrence because we can specify amplitude and any of its derivatives but can we specify a purely rotational occurrence? Does it make sense, for example,

A Joint Amplitude -Frequency Occurance  
Distribution.

Figure 11

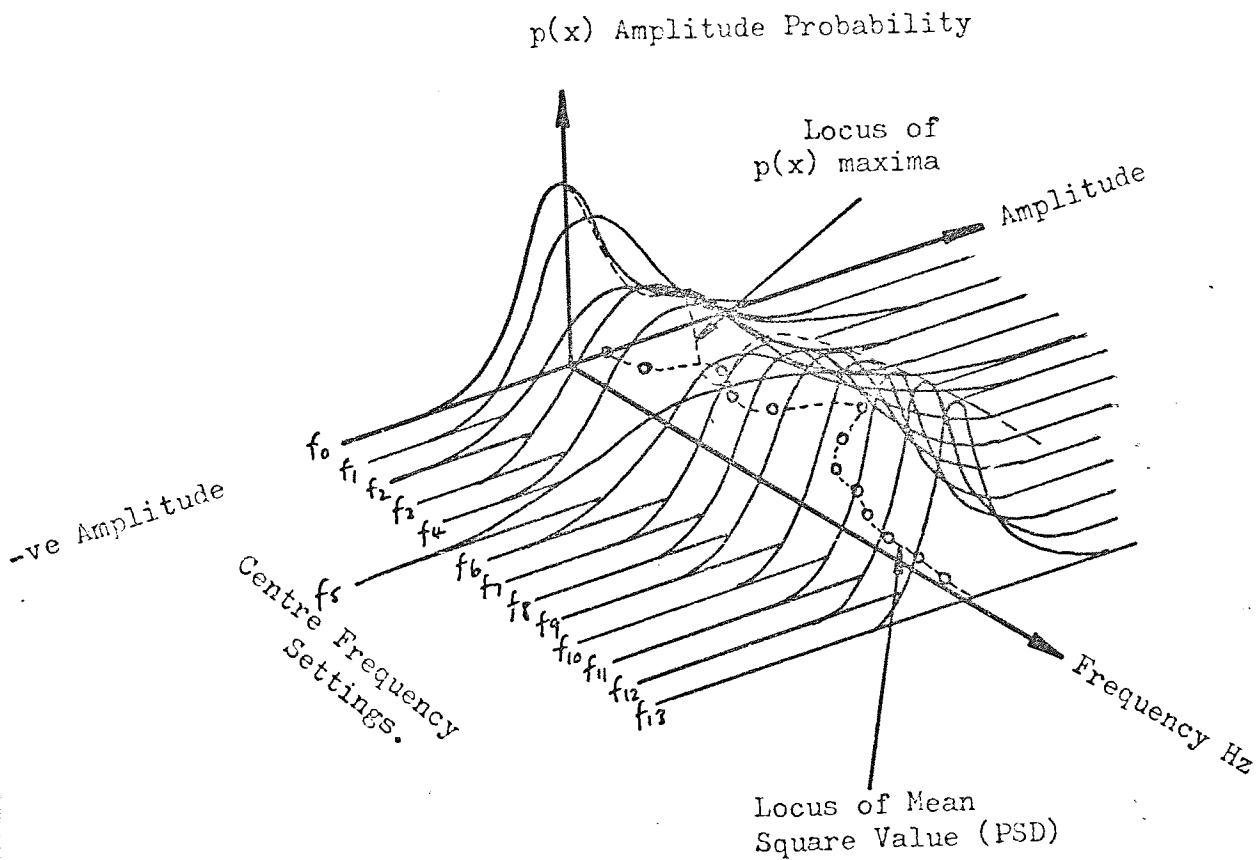

to ask: How much time does the waveform spend at, say, 25 c/s? In a sense the question is specious because by its very nature, frequency is not a distributed variable, it is multi-valued - the waveform can spend all of its time at 25 c/s and at other frequencies as well, in a continuum. Nevertheless, in theory it is possible to answer the above question, not by Fourier Transformation but by a further process of detection after filtration. This is done by measuring the time as a proportion of the full length of the waveform for which there is a filter response to the applied waveform. Another method is to determine the marginal distribution for frequency from a joint amplitude-frequency distribution. Such a distribution is shown in Figure 11. In practice, however, on all occasions when the author has attempted to answer the above question for random waveforms the answer was the same. For the length of the applied waveform and regardless of its centre frequency within its frequency spectrum there was always a response from the filter. In terms of the marginal distribution for frequency in Figure 11 each frequency measured occurred 100% of the time. Consequently for this reason and others an alternative definition of frequency was sought, which would facilitate separation and make some sense of the question posed earlier. This alternative definition is given after the next section.

### 3.2.3 Frequency Scale Unit

The idea of a scale unit as the smallest meaningful interval of a scale is somewhat difficult to apply to the scale of frequency when it is detected by filtration. The operation of a filter is such that any response made by it to an applied random waveform is evidence not of the existence of a single point somewhere on the scale but evidence that an interval or range of frequencies exist in the waveform. To specify

this range for a single filter its frequency response characteristic may be interpreted directly as the probability density of the range along the scale of frequency. Another technique, and it is now the convention, is to specify the interval evidenced by the filter by calculating its EQUIVALENT NOISE BANDWIDTH, BE

$$BE = \frac{\int_0^{\infty} |H(f)|^2 df}{|H(f)_{MAX}|^2} \quad (11)$$

In this equation  $H(f)_{MAX}$  is the maximum response of the filter. For the purpose of partitioning the frequency scale BE may be regarded as the scale unit.

In practice, when it is required to detect the frequency spectrum of a waveform, the aim should be to move the single filter one noise bandwidth along the frequency scale for each pass of the waveform. When this is done and because all practical filters are bell shaped to some extent, some overlap of the catchment area of adjacent filters is inevitable. This means that the response of adjacent filters (or adjacent settings of a single filter) will be related to some extent but the fact does not negate the idea of BE as a minimum meaningful interval because it retains its full functional capability, namely that it allows us, from knowledge only that the filter has responded to define or substantiate with probability greater than one-half a proposition of the form that the frequencies detected fall into the interval :

$$\left\{ \left( f_c + \frac{BE}{2} \right) - \left( f_c - \frac{BE}{2} \right) \right\}$$

and not into  $\left\{ \left( f_c + \frac{3}{2} B\epsilon \right) - \left( f_c + \frac{B\epsilon}{2} \right) \right\}$ .

When frequency is detected by the Fourier method the scale unit is determined by the accuracy with which it is possible to construct a sine wave template. Since in practice it is usual to implement the Fourier method on a digital computer the basic machine accuracy, that is, its number of bits per word, the number of numbers which specify the sine wave and the accuracy of its sine function routine alone limit its accuracy.

#### 3.2.4 An Alternative Definition of Frequency

In this section the aim is to look back at the nature of frequency as it has been described and to consider how it may be re-conceptualised and re-defined in order to overcome some of its conceptual and detection difficulties whilst retaining its fundamental property as an angular velocity or rotational dimension of a waveform.

To do this it is necessary first to take the philosophical position that it does not matter what properties are detected in a waveform or what descriptions are applied to them so long as it can be shown that they are revealing and valid in terms of the objectives of the waveform study. Second it is recognised that in studies where a new definition has no face validity, it will be necessary to conduct a validation study before basing any conclusion on a new definition.

Example of a Waveform Plotted in the  
Phase Plane

Figure 12

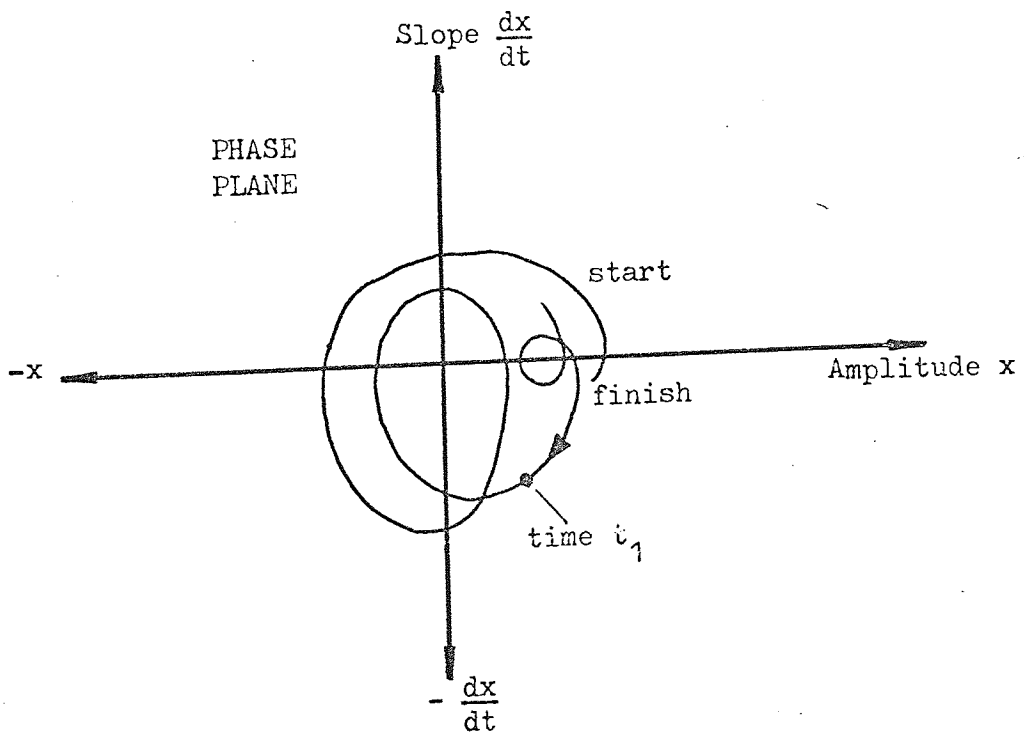
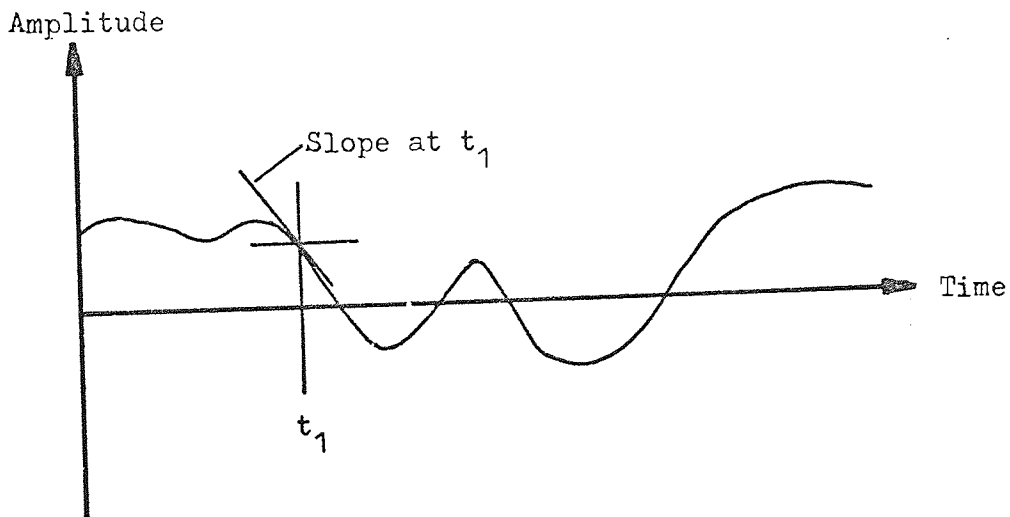

When considering where to look for a new definition of frequency an obvious place seemed to be in the phase plane. Obvious because a waveform re-plotted in this way appears to go round in circles. Not regular circles but irregular ones, the degree of irregularity depending upon the randomness of the waveform. The phase plane as it has come to be known is a graph of amplitude plotted against velocity. It is termed a phase plane because the phase angle between amplitude and velocity for a sine wave is  $90^\circ$  which justifies the use of orthogonal axes. Amplitude  $x$  of the waveform is plotted on the abscissa and velocity  $dx/dt$  on the ordinate. It should be stressed that amplitude and velocity of the waveform are not the only properties which may be plotted in this way. Any motion and its derivatives qualify. Instead of amplitude and velocity it could be velocity and acceleration or acceleration and jerk. All obey the  $90^\circ$  rule which justifies the use of orthogonal axes and the label phase plane.

To convert a waveform into a phase plane plot it is necessary to measure the slope of the waveform at each instant and to plot this together with its associated value of amplitude, in the phase plane. For a small segment of waveform this can be done by hand, quite accurately and an example is shown in Figure 12. Note the circular nature of the plot and the point in the phase plane which corresponds to the instant of time  $t_1$ . In the phase plane plot, time is no longer explicit, it is implicit. It is therefore impossible to reconstruct a waveform from its phase plane plot unless steps are taken to add time marks to the trajectory of the phase point as the plot is generated. In practice the slope of the waveform is measured by differentiation usually by electronic means and the phase plane plot displayed on an XY plotter



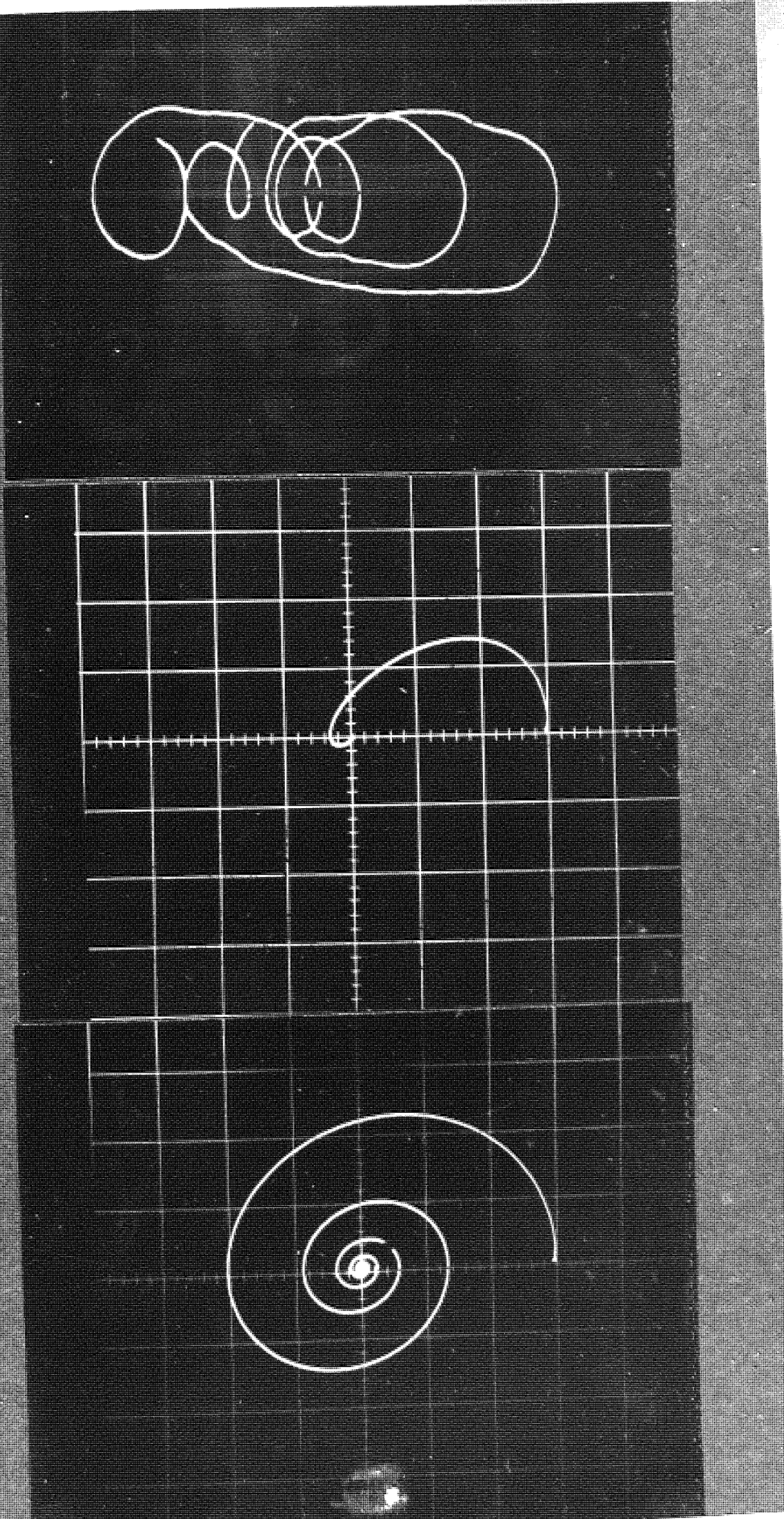

(a) Phaseplane Response of an Underdamped 2nd Order Dynamic System

(b) Phaseplane Response of a 2nd Order System near Critical Damping

(c) Phaseplane Plot of a segment of a Random Waveform



or a storage oscilloscope. An example of the latter is shown in Figure 13 and the former in Figure 14 .

Waveforms plotted in this way have already received a lot of attention both from theoreticians, particularly those dealing with Statistical Mechanics, e.g. Andronov, Pontryagin and Vitt (1933), and by more practical engineers e.g. Crandall, Caughey and Lyon (1963). To the engineer the phase plane plot provides a convenient means of studying the response of non-linear dynamic systems. In statistical mechanics the phase plane plot is used to describe the probability of the mechanism having particular dynamic states. The dynamic states being described by specific regions in the phase plane and their probability by their relative occupation. More consideration will be given to this use of the phase plane plot in a later chapter but it is well to note here that previous users do not appear to have put it to the use which is currently envisaged for it.

If we retain the classical concept of frequency as the angular velocity of a rotating vector and apply this to the motion of the waveform in the phase plane we have the possibility of a new definition. Taking the origin of the plane as the centre of rotation of the vector its length at any instant of time is:

$$\text{LENGTH OF VECTOR} = \left\{ x^2 + \dot{x}^2 \right\}^{1/2} \quad \text{————— (12)}$$

where  $\dot{x} = dx/dt$  is the velocity of the amplitude at time  $t$ . Its other relationships are:

$$\text{ANGLE OF VECTOR } \theta = \text{Tan}^{-1} \dot{x}/x \quad \text{————— (13)}$$

$$\text{ANGULAR VELOCITY } \dot{\theta} = d\theta/dt \quad \text{————— (14)}$$

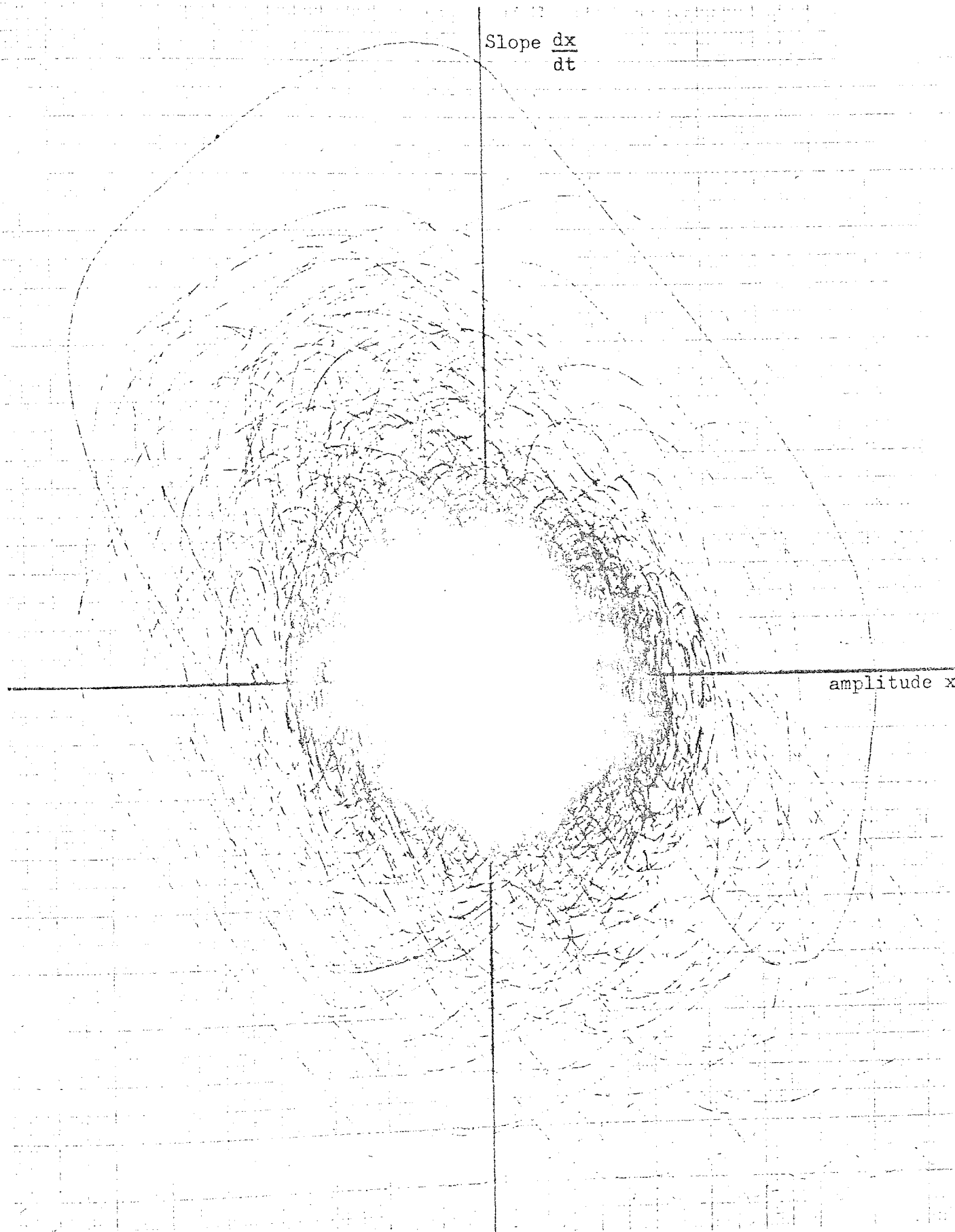

Unfortunately the origin of this vector does not stand still, it can move about along the x axis and this is clearly visible both in Figure 12 and 13a. It occurs whenever the waveform changes the sign of its slope away from the origin of the waveform. It is possible to define an instantaneous centre of rotation of the vector by projecting a perpendicular from the tangent to the trajectory on to the x axis but it requires a quite complex set of rules to locate the instantaneous centre when the tangent is parallel or near parallel to the velocity axis.

An alternative definition which has certain advantages is the point centred angular velocity. This is the instantaneous angular velocity not of a vector but of a point as it travels along the waveform trajectory in the phase plane. To understand this, imagine if you can, that a little car is driving along the path of the trajectory in Figures 12 or 13a. Its forward velocity along these paths will not be constant. It will speed up and slow down in accordance with time as it is related to distance along the trajectory. You will notice that as it moves forward from the starting point it is turning and continues to turn in a clockwise direction from start to finish of the trajectory. It is the speed of turn or yaw velocity of the little car at each instant which is the point centred angular velocity of a point in the phase plane. Another way is to think of it as the angular velocity of the tangent to a point in the phase plane whilst remembering that the point moves along its trajectory with variable speed.

Mathematically:

$$\text{POINT CENTRED ANGULAR VELOCITY} \quad \phi^{\circ} = \frac{d\phi}{dt} \quad \text{radians per second} \quad \text{--- (15)}$$

where  $\phi = \frac{\overset{\circ}{dx}}{dx}$  radians \_\_\_\_\_ (16)

i.e.  $\overset{\circ}{\phi} = \frac{d\left(\frac{dx}{dt}\right)}{d\left(\frac{dx}{dt}\right) dt}$  radians per second \_\_\_\_\_ (17)

or  $\overset{\circ}{\phi} = \frac{d^3x}{dt^2 dx}$  radians per second \_\_\_\_\_ (18)

This definition of angular velocity avoids the vector problem. It gives a more imaginable and better description of the circular information in the phase plane plot and it is a description which is independent of position in the phase plane and therefore orthogonal to its axis.

Clearly this phase plane angular velocity is not at all related to the classical definition of frequency. Nevertheless it is a rotary property and is therefore the same kind of dimension. It does not have the obvious physical importance attached to the classical definition. Neither is it possible to reconstruct a waveform from its phase plane angular velocities. On the other hand the definition does overcome many of the difficulties associated with classical frequency. Although not a visible property of a waveform it is a visible property of its phase plane plot. It therefore avoids the conceptual difficulty of the classical definition which remains largely invisible no matter how the waveform is displayed with the exception perhaps of the toposcope display, Walter (19 ). It is single valued and therefore differentiable but its most outstanding virtue is that it is easily detected and intrinsically separate from amplitude.

Phaseplane Plots of Four Sine Waves  
having the same Amplitude with  
Frequencies - 0.5, 0.159, 0.1 & 0.05 Hz

Figure 15a

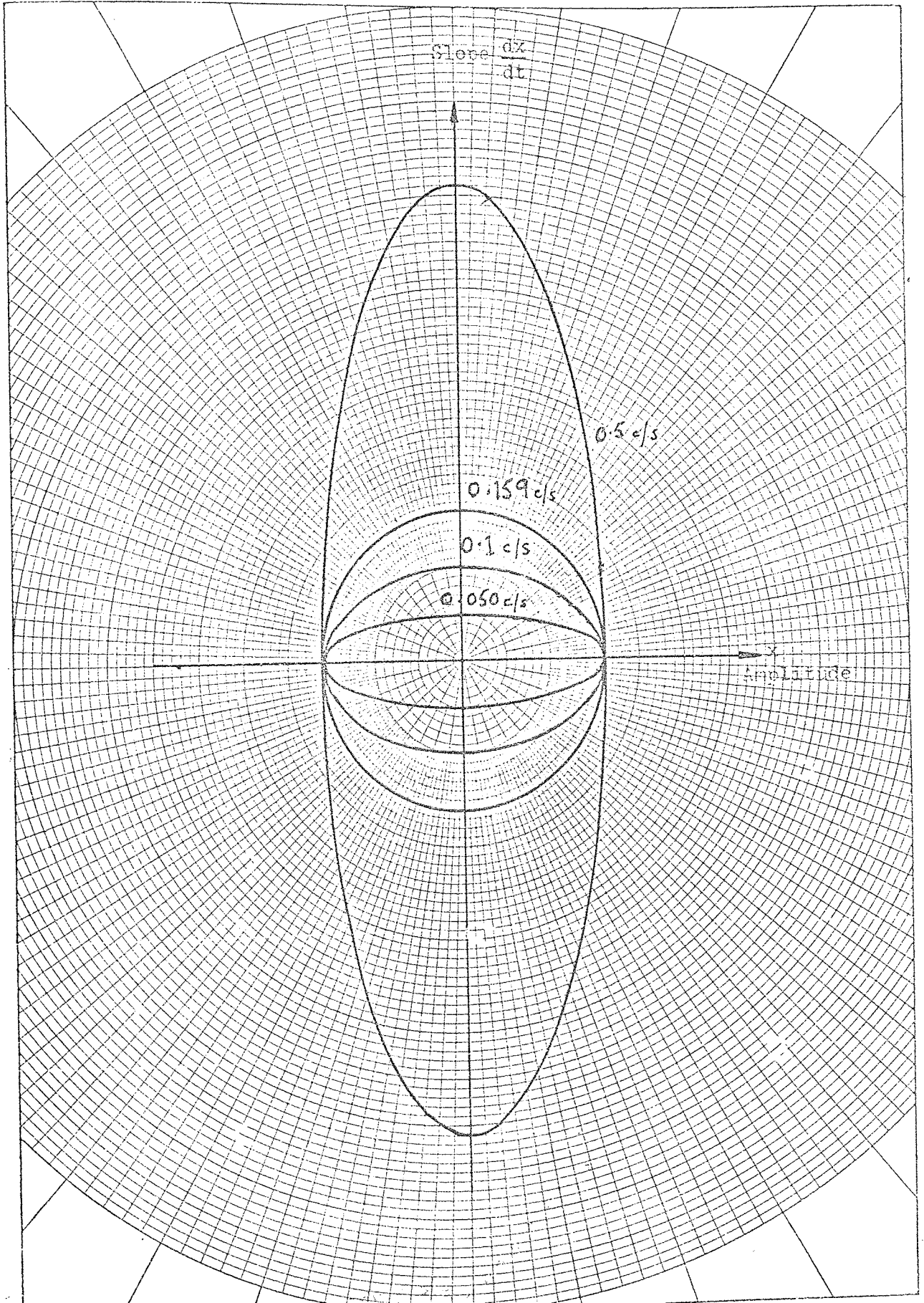

N= 250  
J= 10  
U= 10000.000

AMPLITUDE DISTRIBUTION

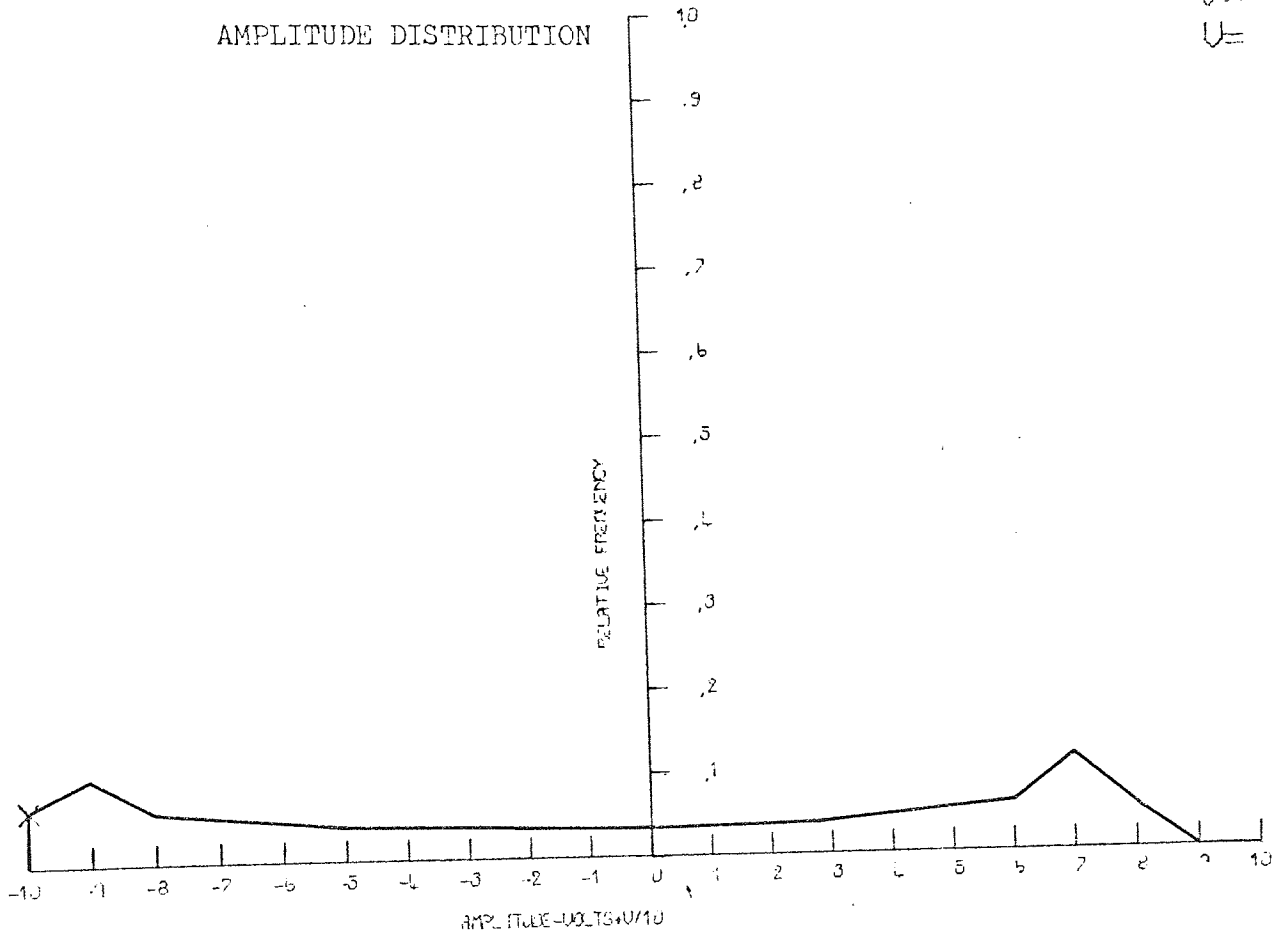
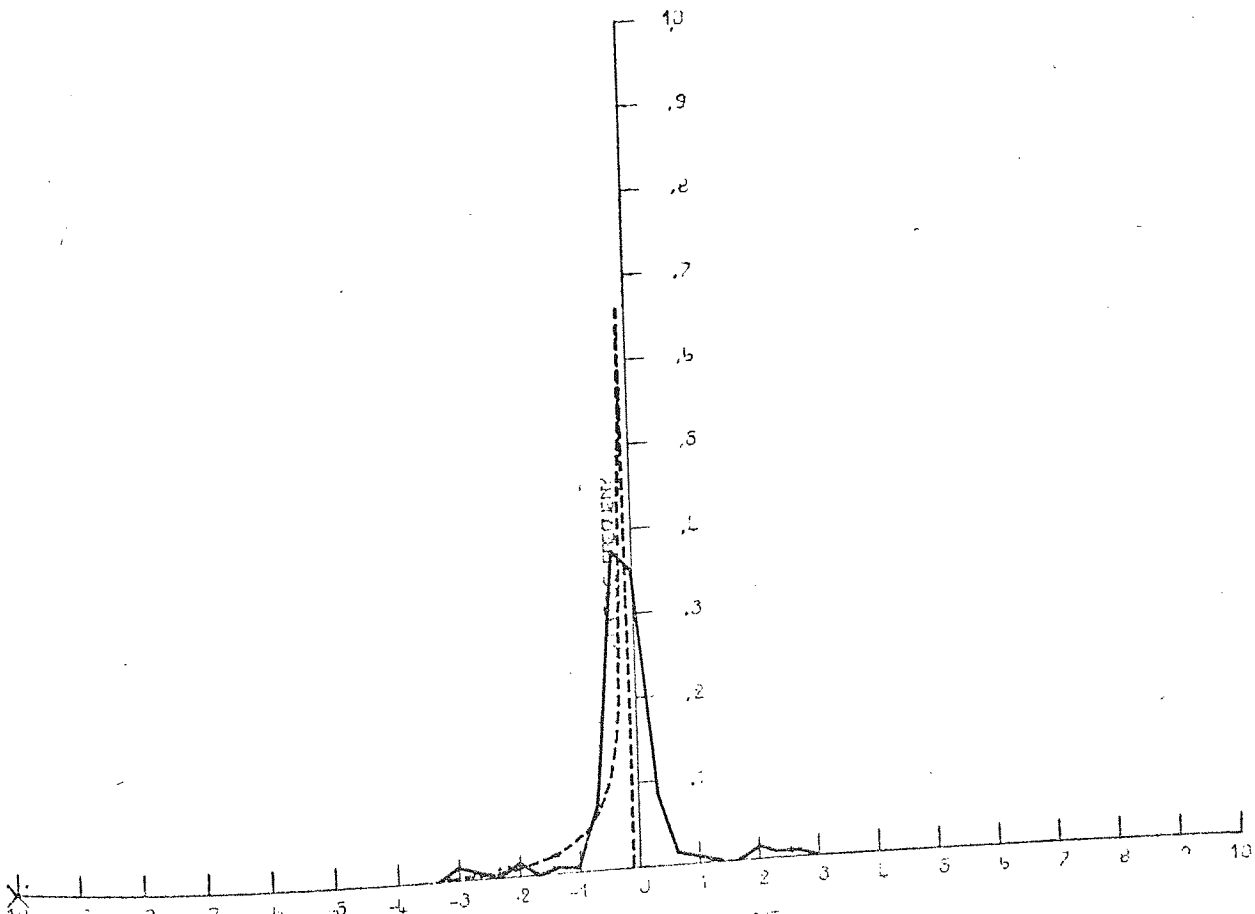

Figure 15c

ANGULAR VELOCITY DISTRIBUTION

T= 0.2 Secs  
L= 30



ANGAMP DISTRIBUTION - 0.1 c/s Sine Wave

N= 250  
T= 0.2 Secs  
U= 10000.000

ANGULAR VELOCITY  
RADS PER SEC  $\approx 0.3142 \cdot T$

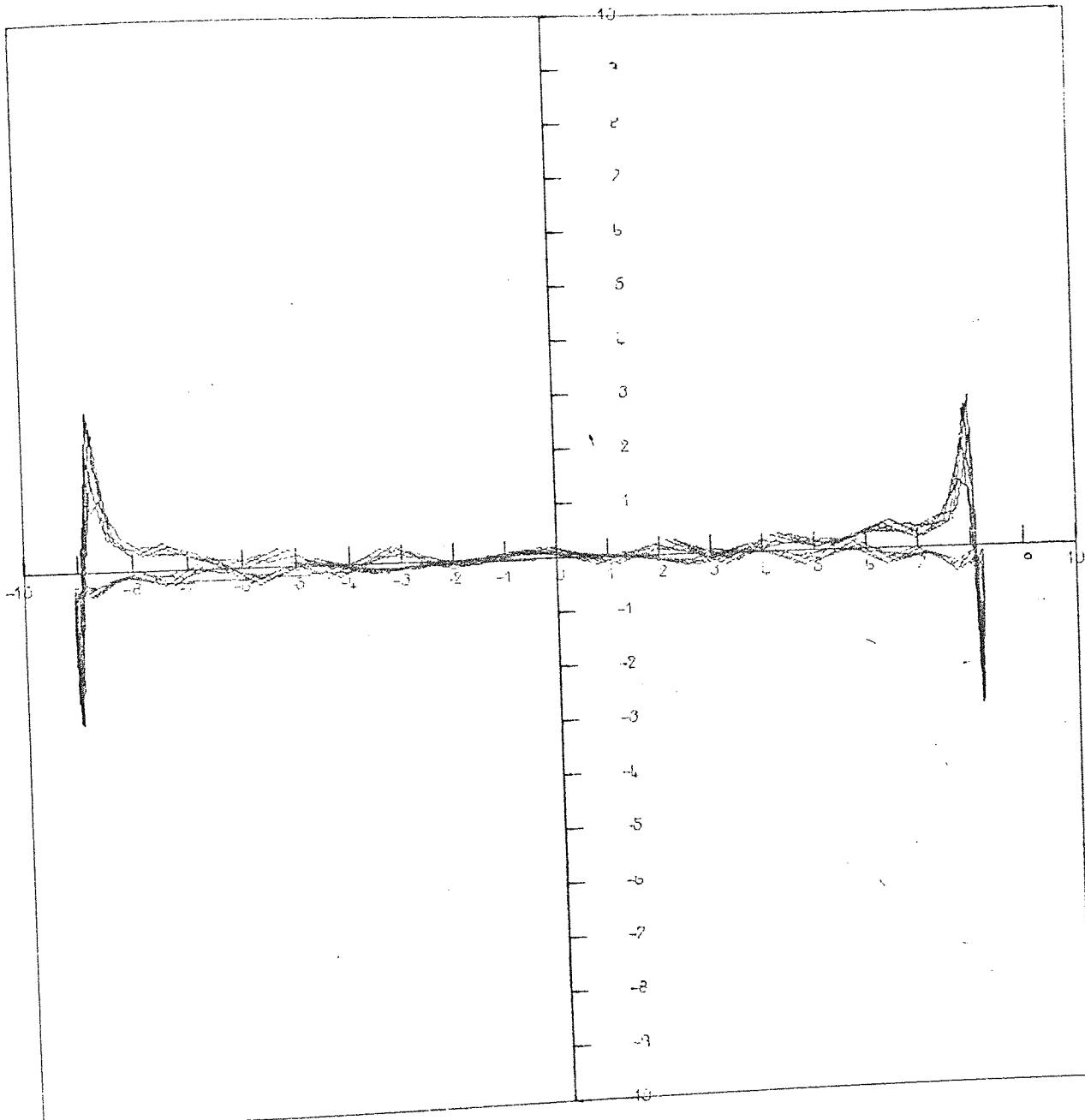

AMPLITUDE  
VOLTS  $\approx U/10$

As a property of a waveform its description is likely to appeal to those who have no need to reconstruct a waveform and for whom the physical importance of classical frequency has no import. It is therefore likely to appeal more to the biological and human scientists than to physical scientists although there are known to be exceptions to both.

Unlike classical frequency, the Phase Plane Angular Velocity (PPAV) can take negative as well as positive values. However, the occurrence of negative values is likely to be rare and restricted to very random waveforms. The convention adopted is the logical one, that positive angular velocity refer to clockwise motion in the phase plane. In the digital computation of this quantity however, the angular velocity of a clockwise motion comes out negative. This is due to the way the angle is defined in the phase plane and is a consequence of finite differences. This should be borne in mind when examining the graphical results.

Detection of the PPAV has been implemented on both the Hybrid Parallel and a pure digital computer. The programmes for both are included in Appendix A, together with programming details. The results presented here to illustrate the technique were obtained from the digital computer. No results were obtained from the Hybrid Computer although the programme presented was proven to the satisfaction of the author.

Figure 15a is the phase plane plot of a series of sine waves. Figures 15 b, c and d show respectively the amplitude distribution, angular velocity distribution and joint occurrence graph between angular velocity and amplitude for the 0.1 c/s sine wave. This latter graph is labelled ANGAMP



# ANGAMP DISTRIBUTION

N= 250  
T= 0.04  
V= 10

ANGULAR VELOCITY  
DEG/SEC \*36/T

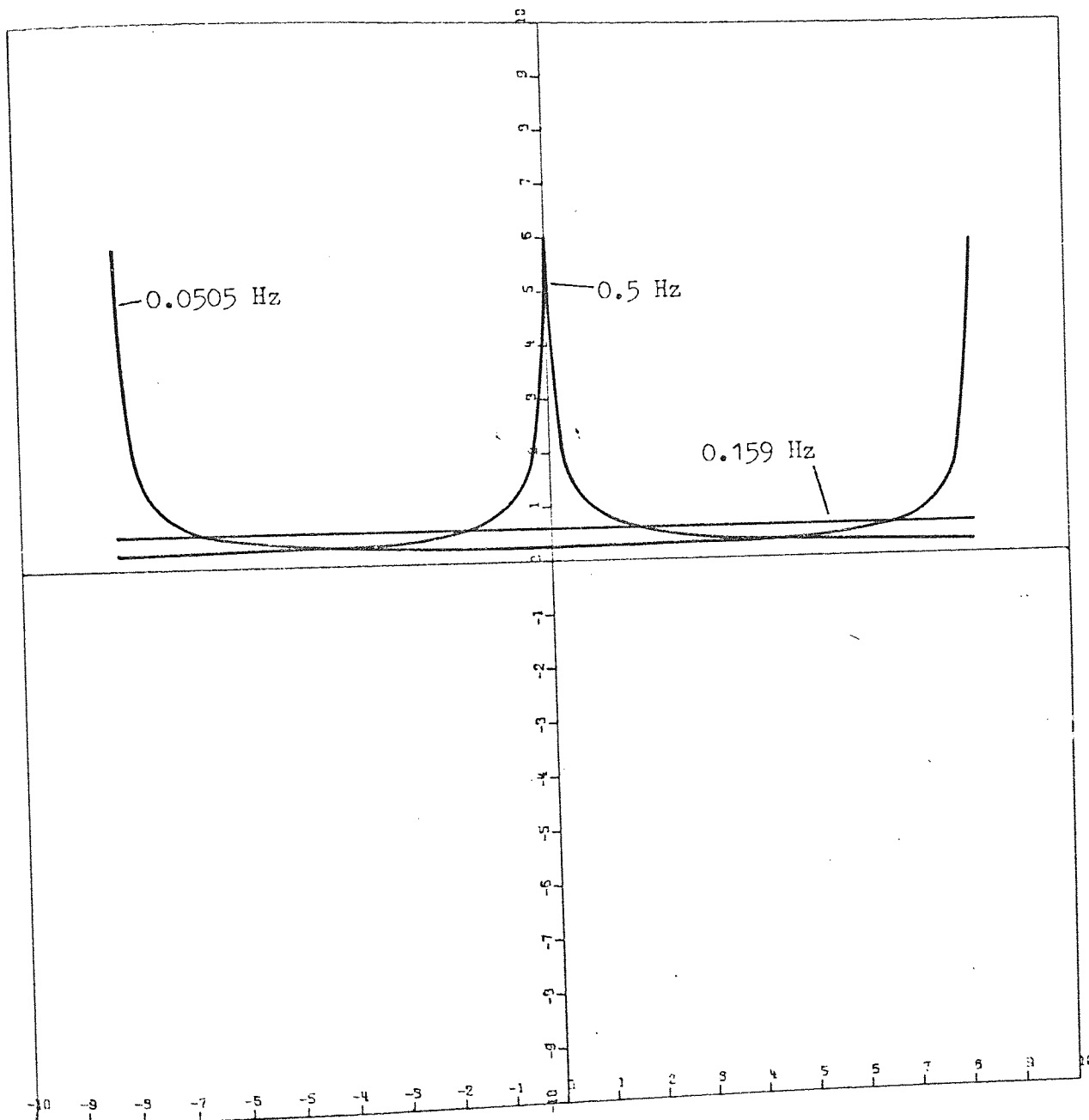

AMPLITUDE  
VOLTS \* V/10

distribution. The descriptions presented are based upon an analysis of just 5 cycles of the waveform made up of 250 digital samples equi-spaced at 0.2 second intervals. The units given for angular velocity are RADIANS PER SECOND normalised to the circular constant  $\pi$  and the sampling interval T. In a later version of the programme (see Figure 16 ) the units were changed to DEGREES PER SECOND to facilitate a more rapid interpretation of angular velocity. By inspecting the elliptical phase plane plot it is easy to imagine qualitatively, how much time is spent by the ellipse at each of its angular velocities. It is clear that there are no negative angular velocities and when it is realised that the vector which traces the elliptical path is rotating with constant angular velocity it is clear that the point centred angular velocity spends more time at low values of angular velocity than at high values. This is a quality which appears in both the joint and marginal distribution for angular velocity (Figures 15c and 15d ) but the non-negative quality does not. Examination of the original programme revealed that the major cause of this error was a fault in the evaluation of angles in excess of  $180^\circ$ . In Figure 15d the effect of this is seen as a jump from positive to negative values of angular velocity at maximum and minimum amplitude and it was a fault easily corrected. A second cause which gave rise to the saw tooth effect in Figure 15d is due to the combined effects of quantisation error in digitisation and finite difference errors. The initial reaction to this problem was to smooth the digital phase plane plot as shown in Figure 17 . Using angles calculated from the interpolated centre points of the line segments most of the sign changes in the angular velocity were eliminated, at least for sine waves but less so for random waves. Later when it was realised that the incidence of negative angular velocities was very small (at least in the waveforms studied in Part II, see Figure 2.112 etc.) at the

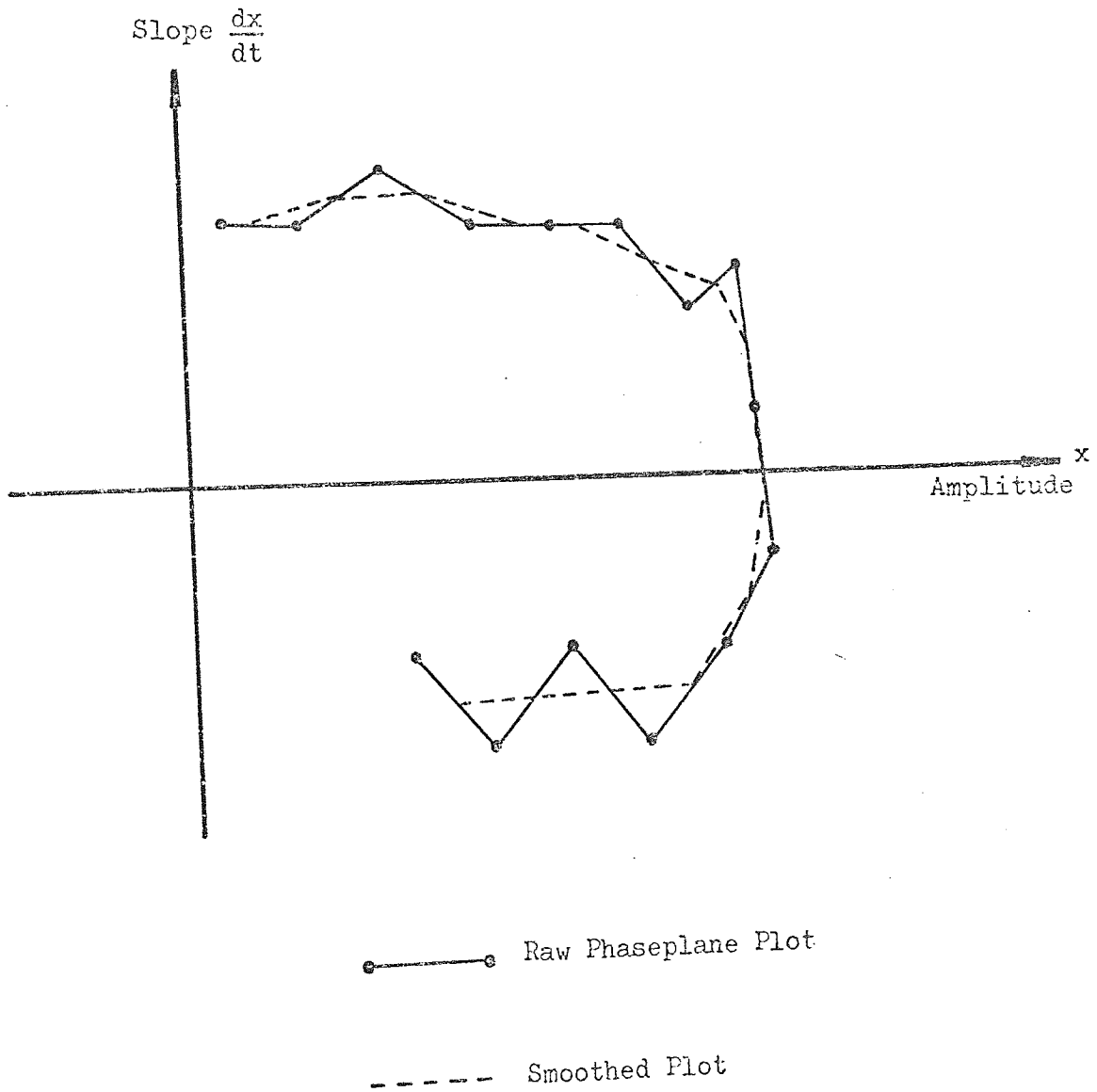

N= 4.00

T= 0.2 Secs

U= 2000.0000

ANGULAR VELOCITY  
RADS PER SEC  $\#0.3142 \times T$

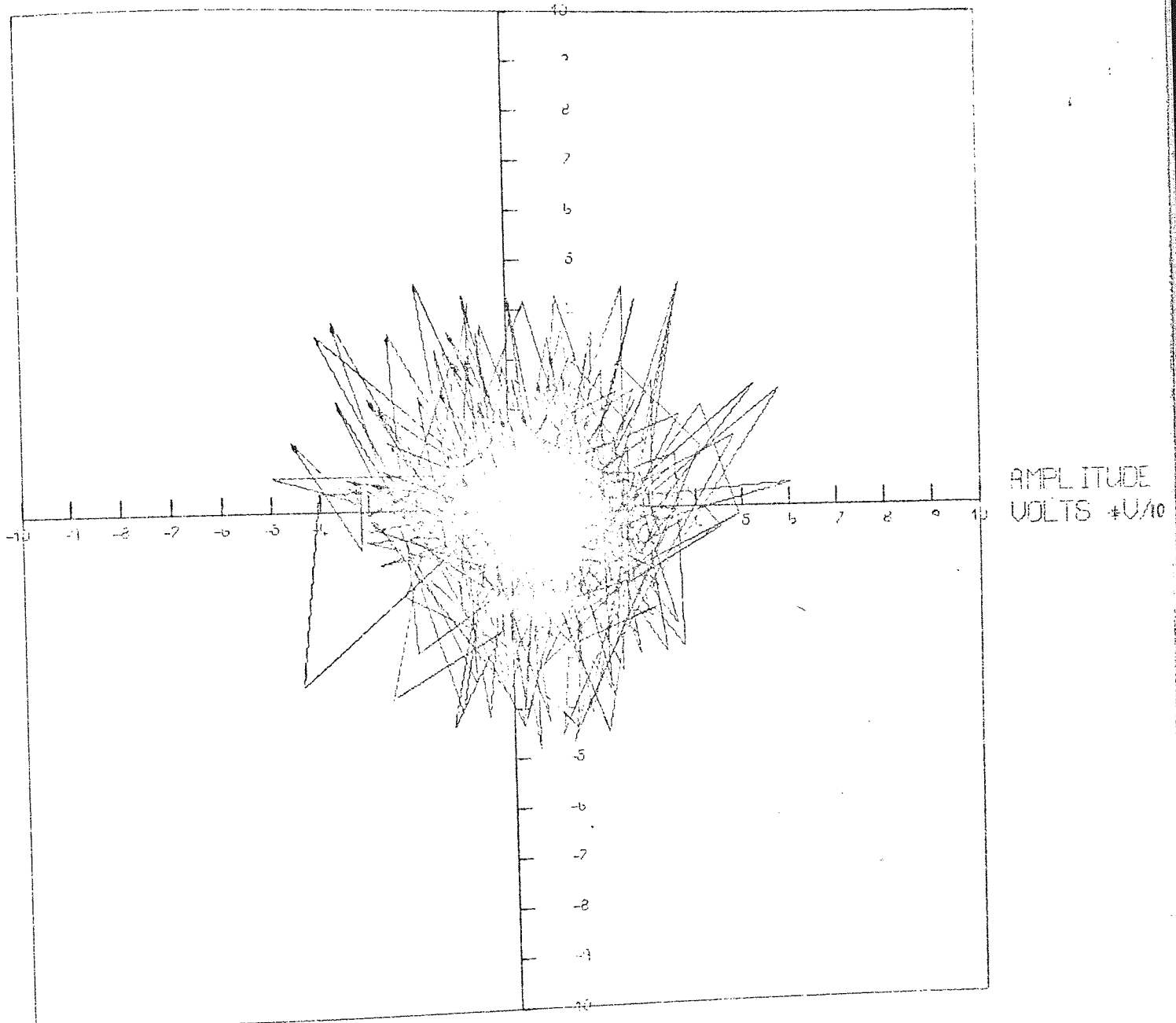

N= 100  
J= 20  
U= 2000,0000

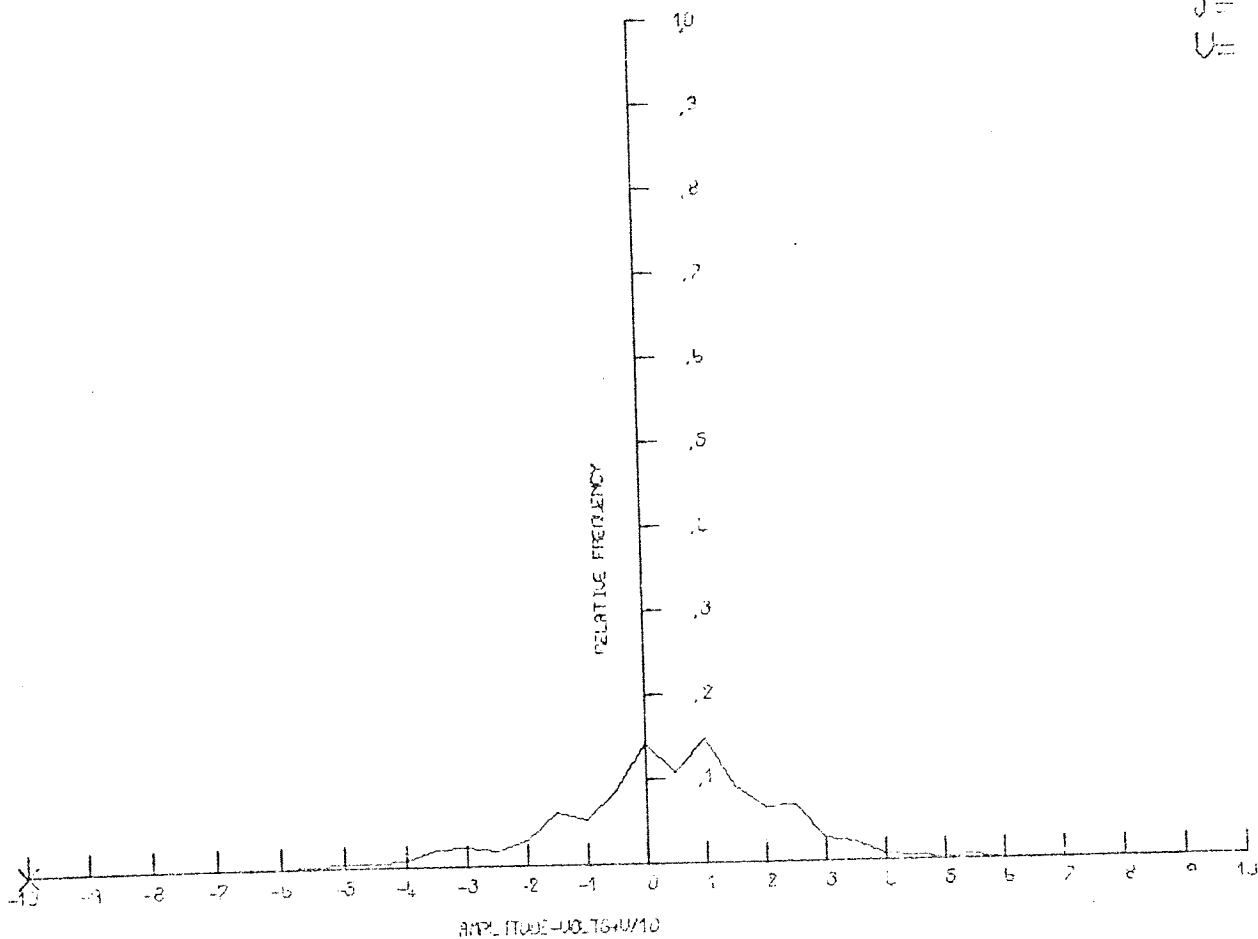

ANGULAR VELOCITY DISTRIBUTION

T= 0.2 Secs  
L= 30

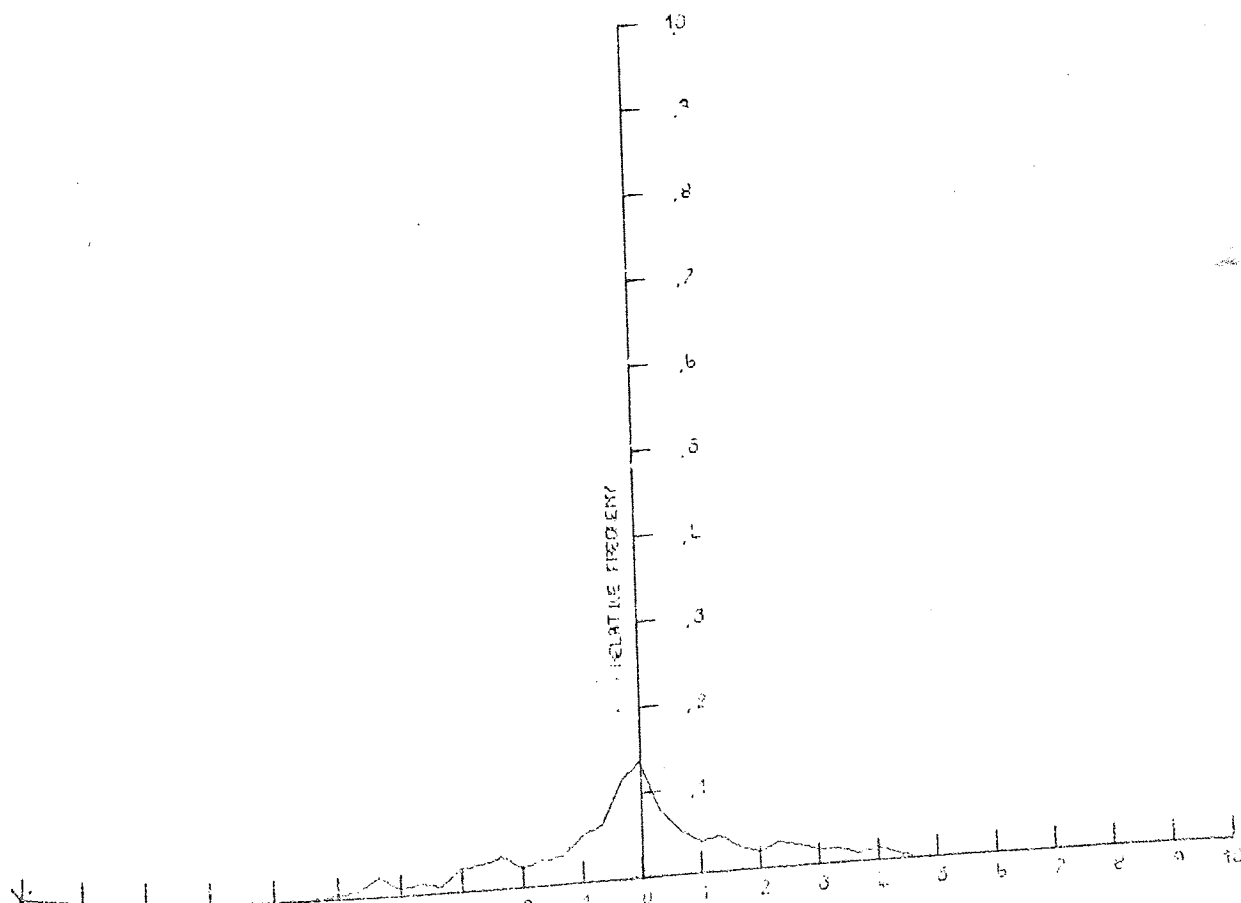

A Series of Event Waveforms whose  
Phaseplane Plots and Angular  
Velocity Distribution are shown in  
Figs. 19b & 19c.

Figure 19a

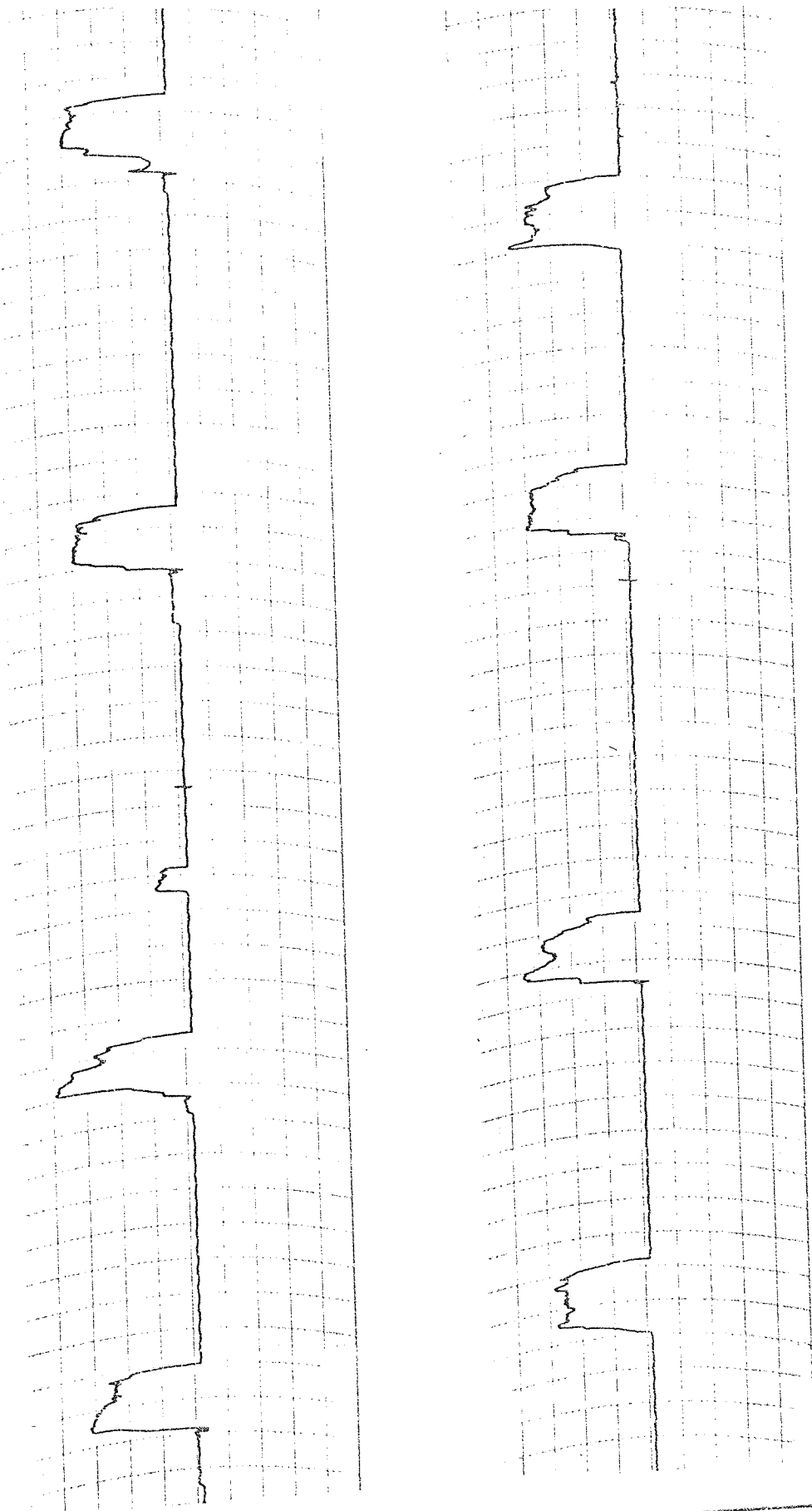

of Event Waveforms  
shown in Fig 19a

Figure 19b

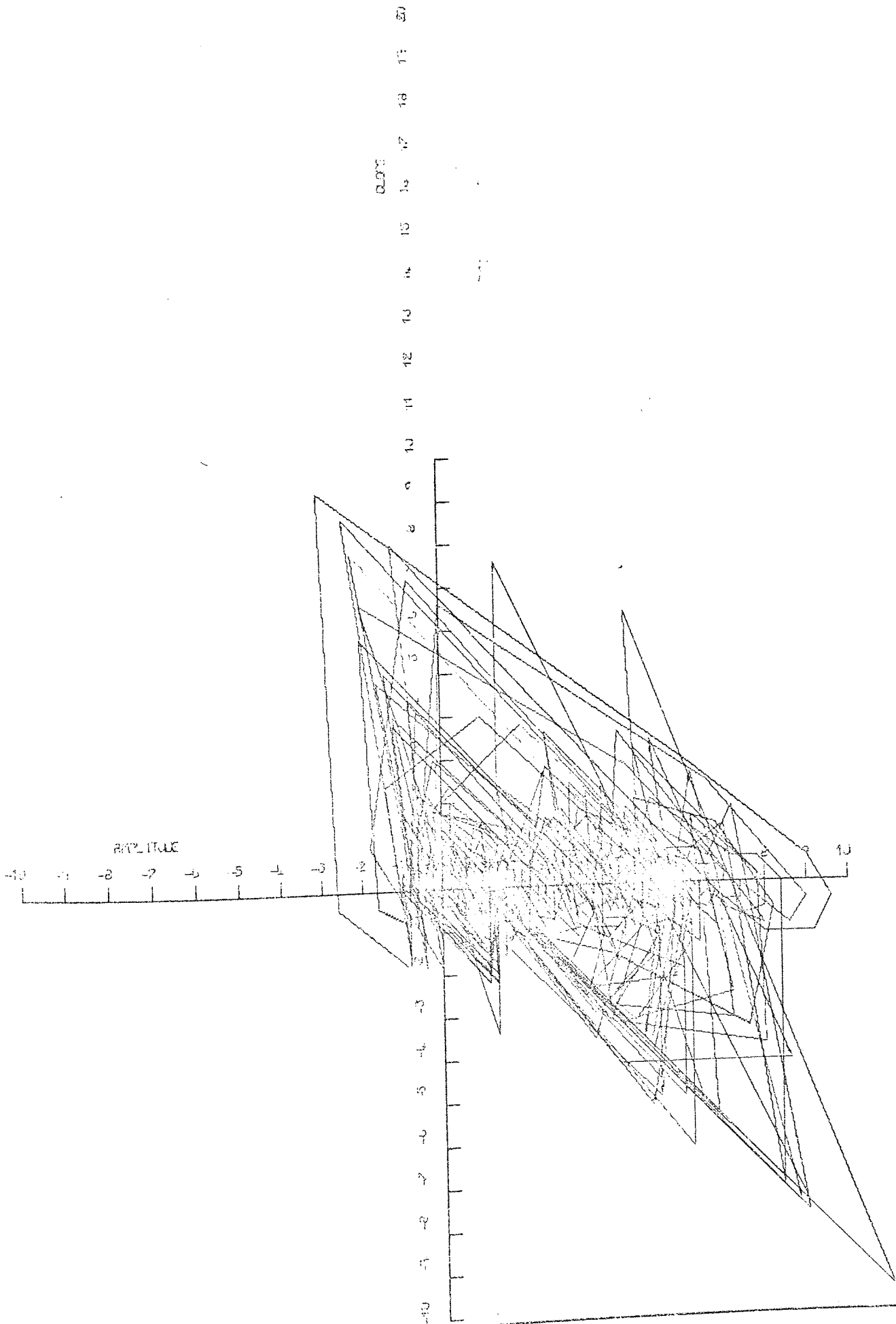

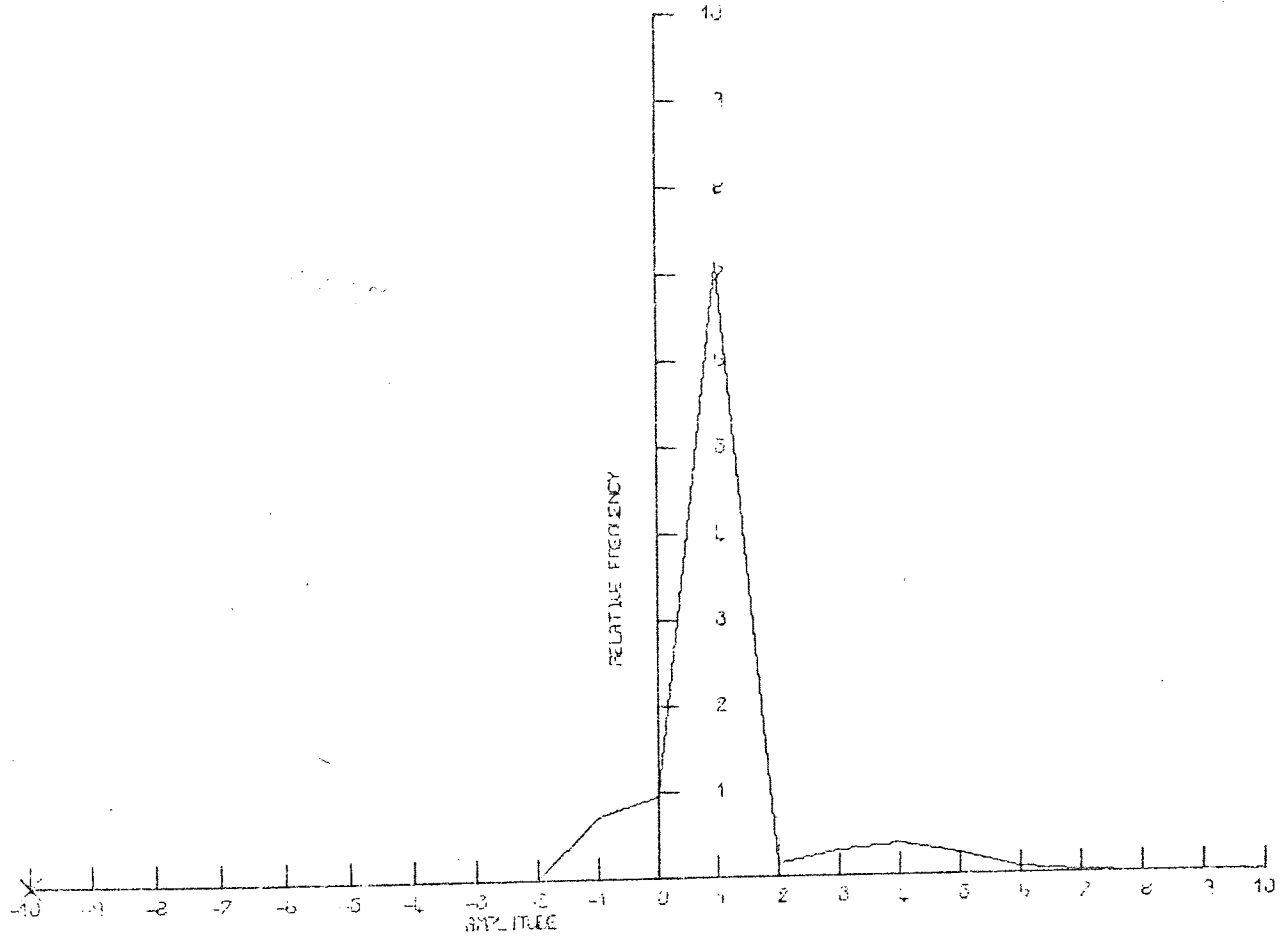

ANGULAR VELOCITY DISTRIBUTION - For the Event Waveform shown in Fig 19a

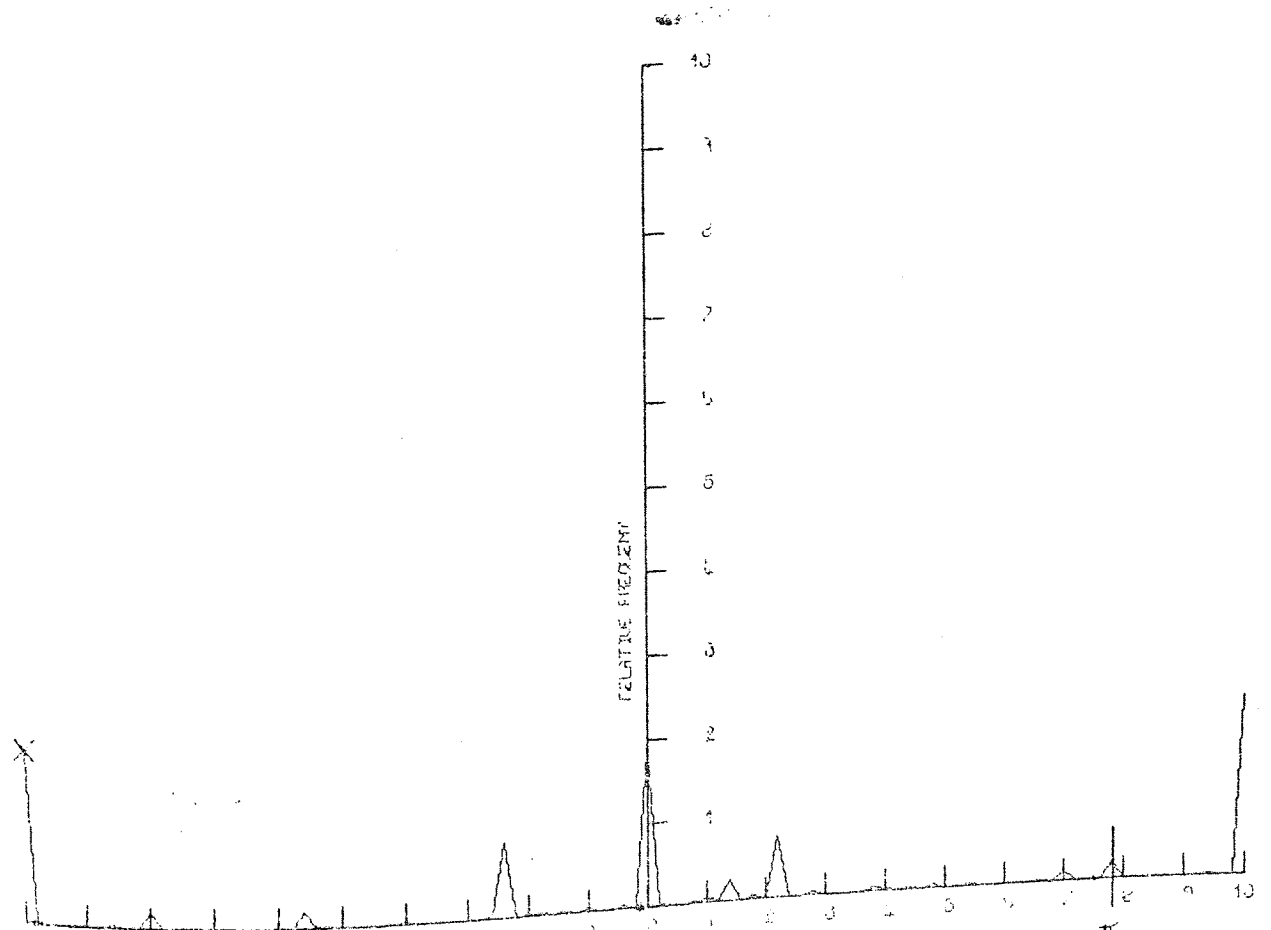



expense of a small loss of definition it was decided to provide an option both to smooth the phase plane in accordance with Figure 17 and to fold velocities on to the positive half of the scale - thereby making the scale one sided like classical frequency. This was the final version of the programme and was the form in which it<sup>was</sup> applied to waveforms in Part II of the study. To prove the programme it was applied to the special sine waves with frequencies 0.5, 0.159 and 0.0505 c/s whose phase plane plots are shown in Figure 15a. The sine waves are special in the sense that 0.5 and 0.0505 c/s have similar ellipses in the phase plane and therefore the range of angular velocities<sup>is the same</sup> and a sine wave at 0.159 c/s has a circular phase plot and therefore also a constant point centred angular velocity. The joint occurrence, ANGAMP distribution for each sine wave is shown in Figure 16. In contrast to the sine waves Figures 18 and 19 present the results of an analysis of a random waveform and a waveform in the nature of a series of events. In each case both smoothing and folding were excluded. The joint occurrence result for the random waveform is a nice demonstration of the general independence between the amplitude and PPAV. In Part II of the thesis and briefly in the next chapter descriptions based upon Phase Plane Angular Velocity are compared to descriptions of the same waveform based upon classical frequency and zero crossing analysis.

### 3.3 THE WIENER/KHINCHINE METHOD OF FREQUENCY DETECTION

Whilst considering alternative methods of frequency detection it is appropriate to mention a variation of the basic Fourier method. This method uses what has come to be known as the Wiener/Khinchine relationship - sometimes referred to, with some ambiguity, as the Fourier Integral. As the word integral suggests it gives an average description of the frequency

content of a waveform and can in no way detect an IFS. It is an indirect method which detects frequency by comparing COSINE templates with an AUTOCORRELATION description of the waveform. The method is applicable to waveforms which are known to have a continuous frequency spectrum, which are not a superposition of sine waves and where it is expected that the rotating vector in the classical concept of frequency will change both in its existence and in its length. By definition therefore it is a method applicable to RANDOM waveforms. The method does not permit the waveform to be re-constructed from the frequency spectrum detected by the method, but it can re-construct the waveform of the autocorrelation description because they are transform pairs.

i.e.

$$\text{FREQUENCY COEFFICIENT} = G_x(f) = \frac{1}{T_\tau} \int_0^{T_\tau} R_x(\tau) \cdot \text{Cos}(2\pi f \tau) d\tau \quad \text{--- (19)}$$

$$\text{AUTOCORRELATION COEFFICIENT} = \begin{cases} R_x(\tau) = \int_0^{f_\infty} G_x(f) \text{Cos}(2\pi f \tau) df & \text{--- (20)} \\ R_x(\tau) = \frac{1}{T-\tau} \int_0^{T-\tau} x(t) \cdot x(t+\tau) dt & \text{--- (21)} \end{cases}$$

for  $0 \leq \tau \leq T/10$ .

Where  $\tau$  is a time delay (secs) and  $T_\tau$  is the length of the Autocorrelation waveform. Note that the reconstruction of the Autocorrelation waveform is a sum of COSINE waves where the peak amplitude of each wave is specified

by the frequency coefficient.

The Autocorrelation Coefficient  $R(\tau)$  is the 1st product moment correlation coefficient between the waveform and a template which is a copy of itself. The measure of agreement given by the product moment coefficient is calculated between the waveform and its copy for a series or a continuum of alignments, specified by the time delay  $\tau$ .

$$R(\tau) = \frac{1}{T-\tau} \int_0^{T-\tau} x(t) \cdot x(t+\tau) dt \quad \text{--- (22)}$$

Frequencies which are contained in the waveform are preserved in the Autocorrelation waveform, because the rate of change of agreement between the waveform and its copy, with respect to the misalignment variable  $\tau$ , are equivalent to the rates of change of state present in the original waveform. Waveforms which change state rapidly with time, rapidly disagree with their copy when they are misaligned and vice versa for waveforms which change state slowly. Consequently, since the rates of change in the original waveform are represented in the Autocorrelation waveform and since they have the same definition of frequency, it is reasonable to argue that their frequency content is the same. When the original waveform is a sine wave, or square wave for example, it is easy to imagine how the process of preservation works. For random waveforms it is more difficult, but for many people it is probably a lot easier to do this than to understand the mathematical proof of this preservation process given by Wiener (1933).

The Autocorrelation function has many more interesting properties some of

which together with details of its Fourier Transformation are given in the next chapter.

### 3.4 THE TRANSITION OF STATE IN A WAVEFORM

For all practical purposes it is sensible to regard a waveform as specifying the outcome of a series of discrete events. Each event being the freedom to make just one transition to an alternative state. The state being specified by the occupation of some interval along the scale of position, velocity, acceleration and angular velocity (as defined in the phase plane).

Clearly, although a waveform may appear to change continuously there is an interval of time during which the state of the waveform may be regarded as fixed. The lower limit to this interval is specified by the minimum time that it takes to travel between minimum meaningful intervals along the scale with the largest scale unit.

i.e.

$$\Delta t = \frac{1}{x_{MAX}^0} \cdot \Delta x \quad \text{--- Secs.} \quad \text{--- (23)}$$

where  $x^0_{max}$  is the maximum velocity which occurs in the waveform and  $\Delta x$  the scale unit of amplitude. It has become customary, however, to specify the equivalent number of events in a waveform in terms of the highest frequency present in the waveform.

i.e.

$$\text{EQUIVALENT NUMBER OF EVENTS} = n = 2BT \quad \text{--- (24)}$$

where B c/s is the highest frequency component in the waveform and T the length of the waveform. This relationship is derived from cardinal

reconstruction theory so that any waveform which is sampled at intervals  $\frac{1}{2}B$  secs apart can be completely reconstructed at every instant by using the relationship

$$x(t) = \sum_{n=-\infty}^{n=+\infty} x(n/2B) \cdot \left\{ \frac{\sin \pi(2Bt-n)}{\pi(2Bt-n)} \right\} \quad \text{--- (25)}$$

an example of such a reconstruction is shown on page 57 Reference 2.

The sampling interval  $\frac{1}{2}B$  is an important entity in analog to digital conversion but it is not rigidly adhered to in practice. Intervals smaller than  $\frac{1}{2}B$  are often used where it is required to display a waveform in digital form without using the above reconstruction relationship.

The random waveform in Figure 7 is an example where a sampling interval  $\frac{1}{8}B$  secs was used.

In terms of the title to this chapter the equivalent number of events specifies the number of independent states which can occur in a waveform and when they occur. It does not specify what can occur or what is expected to occur next in a waveform. This latter aspect of transition is covered in the next chapter under the heading Order Structure.

#### SUMMARY

A waveform is the time history record of the state of a measured variable. It is a complete picture showing each and every state and the order in which

they occurred. At each instant of time the state of the variable is specified by the position of the waveform from its origin, by its slope, by the rate at which the slope appears to be changing at that instant and by higher rates of rate of change which are not easy to visualise. The distance of the waveform from its origin at each instant is its static state at that time and the other qualities velocity, acceleration and jerk specify its dynamic state in translation. Frequency is an abstract expression of the rotary dynamic state of a waveform. It is not a direct visible property of the waveform but a mental template of a sine wave does permit some degree of visual recognition. The nature of frequency is such that at any instant of time it is multivalued. It has an Instantaneous Frequency Spectrum because the detection of frequency is an expansion process. In the form in which it is detected it specifies a joint occurrence between frequency and an "expanded value of amplitude".

Three methods of frequency detection were described and distinguished both conceptually and quantitatively. Only one method - Filtration - is capable of giving an Instantaneous Frequency Spectrum. The two other methods define an average spectrum. Although an abstract rotational property of a waveform, frequency has important physical significance when the waveform is of physical origin. When the origin of the waveform is such that frequency has no physical significance or no importance it may be worthwhile to consider an alternative definition of frequency. By visualising the waveform as a phase plane plot a definition of frequency is facilitated which overcomes many of the conceptual and detection difficulties associated with classical frequency. By calculation<sup>of</sup> the point centred angular velocity of the trajectory of the waveform in the phase plane a visible rotary state may be specified alongside the translational states which is both separate

from and orthogonal to the translational states. It is single valued and therefore differentiable and it has the advantage that it is easily detected. Theoretical details of the technique together with the computer programmes used to detect it are given in the chapter and in Appendix A.

A limit to the accuracy with which waveform states may be quantised, including the time state may be specified by a SCALE UNIT which is the minimum (meaningful) interval of scale below which we either cannot define or substantiate with probability greater than one half a proposition that the state falls into a specified interval and not into the interval adjacent to it. For the scales of translation and the scale of angular velocity defined in the phase plane the size of the scale unit is determined by the basic measurement accuracy and overall signal to noise ratio of the equipment involved in the waveform study. In the case of frequency, when it is detected by filtration, the scale unit is the Equivalent Noise Bandwidth of the filter.

The scale unit also places a restriction on the maximum number of independent states which are contained in a fixed length of waveform. The minimum state transition interval is specified by the scale unit of the state divided by the maximum velocity in the waveform and the maximum number of independent states by the product of this ratio with the length of the waveform. The sampling theorem based upon cardinal reconstruction theory uses the highest frequency present in a waveform  $B$  c/s to specify the Equivalent number of events,  $n = 2BT$ .

To specify the result of an elementary transition in the state of a waveform it is sufficient in most cases to specify the end point co-ordinates of an

elementary trajectory in the phase plane, that is in the two dimensional space of amplitude and velocity. Further dimensions may be added to the state space in the form of higher derivatives such as acceleration and jerk but only when the objectives of the waveform study demand an explicit specification of their state, otherwise they remain implicit in the phase plane. The same argument applies to the visible qualities of rotation as in the phase plane. They too may be added as orthogonal axes to the state space to increase the specificity of waveform state.

Frequency on the other hand is something quite separate because it is an abstract transformation of the waveform. Nevertheless it is quite legitimate to include dimensions of frequency in the state space description or alternatively an instantaneous frequency spectrum may be used to specify an entirely separate but conceptually related state space. In terms of state space description changes in state, of course, are conceived as changes in the position of occupation of the space.

Together, the dimensions used to specify the instantaneous state of a waveform define its instantaneous structure. It is important not to confuse this structure with the Temporal Structure considered in the next chapter. In terms of the formalism of McKay (1950) the structure of a waveform is a prior property of the measured variable. Measurement being the posterior act whereby the state of the variable is categorised within its structure at each transition time. The number of independent categories within the structure into which the state may fall specifies the amount of structure in the waveform. Each category is termed a LOGON and the total number of categories the LOGON CONTENT. For a waveform of length  $T$  secs with frequency bandwidth  $B$  c/s, which it is proposed to describe along



dimensions of amplitude, velocity and frequency, the logon content is given by:

$$L = \left\{ x_D / \Delta x + \dot{x}_D / \Delta \dot{x} + (x_D / \Delta x \cdot B / B_E) \right\} \cdot 2BT \quad (26)$$

where  $B_E$  is the equivalent noise bandwidth of the frequency filter  $\Delta x$  and  $\Delta \dot{x}$  the amplitude and velocity scale units and  $x_D$  and  $\dot{x}_D$  the amplitude and velocity dynamic range.

Many features of interest which occur in a waveform have no explicit mention in this chapter because the interest is more in how they occur collectively than individually. For this reason it was thought more proper to deal with them in the next chapter. The features in mind include the specific states of peaks, valleys, zero crossings and events which are an outstanding pattern of these states.

4. THE DESCRIPTION OF FEATURES AND PATTERNS OF OCCURANCE IN A WAVEFORM

The complete pattern of occurrence which is captured in a waveform may be broken down, for the purpose of description and data reduction, into an analytical structure where time is the reference co-ordinate. Because of the reference to TIME we shall label this the TEMPORAL STRUCTURE of a waveform. In the terminology of Garner (1962) this would be referred to as the INTERNAL STRUCTURE of the waveform. The structure is specified as:

1. The relative frequency with which the possible states occur or stated another way; the relative occupation time of each logon. In both cases the occurrence/occupation is relative to some time interval T seconds which may be less than or equal to the total length of waveform.
2. The order with which the states or logons occur in the relative time interval T seconds.
3. Changes over time which occur in the relative frequency and order as specified in 1. and 2. above.

The first specification will be labelled the SPATIAL structure to conform with the idea of state space, the second the ORDER OR SYNTACTIC structure and the last the NON-STATIONARY structure. We may regard each as a component specification of the STATISTICAL STATE of the waveform, where it is understood that each component specifies a separate collective quality of the instantaneous state but does not add any new dimensions to the waveform. Any analytical structure or description thereof, including permutations, which does add a new dimension we shall term a TRANSFORMATION of the waveform.

In addition to its application to the pattern of instantaneous states, each component of the Temporal Structure may be applied equally to a sequence of

features or events which occur in the waveform. To distinguish between a feature and an event the former will be used to describe specific states which occur in the waveform, such as a peak or a zero or a time and the latter to describe an outstanding pattern of occurrence of short duration.

#### 4.1 Occurrence Relationships

In order to breakdown a waveform into each of its Temporal Structures, it is necessary to relate in some way each state to all others which occur in a manner relevant to the respective structure. There are a variety of methods applicable to each structure. The result in each case is an occurrence relationship, knowledge of which makes it possible to proceed to a statement of collective occurrence. The various methods may be classified according to the type of occurrence relationship specified, they are:

1. Elementary Occurance
2. Statistical
3. Transformational
4. Functional
5. Joint/multiple
6. Combined.

#### Definition:

1. Elementary Occurance relationship is the specification of:
  - a) an interval of scale  $(D + W) - D$ , where  $D$  is the scale magnitude and  $W$  the scale interval.
  - b) a scale interval occupation time  $t_w$  relative to the time interval of the Temporal structure  $T$  seconds.

c) the dimension of state, feature or event whose interval occupation time is the subject of measurement.

An Elementary Occupance Relationship is therefore a measure of the time spent by some attribute of the waveform in just one interval of some scale over the interval of time T seconds. There is no restriction on either the choice of scale, scale interval, state feature or event. When the time spent is measured for a set of contiguous intervals which span the dynamic range of the scale (the set of scale intervals may or may not be equal) the result is a histogram.

2. Statistical Relationships - specify quantitatively some pervasive quality of the pattern of occurrence in the waveform over the interval of time, T seconds, of the Temporal Structure. To fulfil the conditions of a Statistical Relationship the full pattern of occurrence, without exception, must participate in computation of the average. Such relationships may be derived from the previous method of categorisation if and when the histogram can fulfil the above condition.

Again there is no restriction on the scale to which the Statistic may be applied but by definition this occurrence relationship is not applicable to features and events since in general neither is a pervasive quality. If, however, the features and events are extracted from the waveform for examination as a separate class of occurrence (as a group they have a pervasive quality) it is then legitimate to obtain a Statistical Relationship for them.

Correlation and Regression coefficients, the mean value, variance, the moment of histograms, are all examples of the statistical class of

relationship.

3. Transformation Relationship - any relationship which is based upon either a rearrangement of the pattern of occurrence or which introduces a new dimension or scale of description will define a transformation relationship. Frequency analysis is an example of this class of relation because it introduces a new dimension of description.

4. A Functional Relationship is functional in the mathematical sense of an equation. The function is the link between the magnitude of occurrence along two or more scales. The function may be deterministic or probabilistic. If it is probabilistic, the function specifies for a given magnitude along one or more scales the probability of magnitude along another. When applied direct to a waveform the function is a TIME FUNCTION. Unlike the other methods the functional method is not always applicable and does not always yield an occurrence relationship. The reason for this is that the pattern may be so complex that no one 'link' is a satisfactory specification for every joint occurrence. Most random waveforms conform to this specification which means that there are no TIME FUNCTIONALS for random waveforms. For random waveforms the Fokker/Plank equation, which is of the probabilistic type, can sometimes yield a relationship for the occupation of state space.

When combined with other methods of classification, particularly the Elementary Occurance method the possibility of deriving a Functional relationship arises. Its greatest asset, perhaps, is the ability of the method to generate patterns of occurrence for use as templates. Well known examples are the Sine, Gaussian and White Noise Functions.

T A B L E I

CHECKLIST FOR WAVEFORM DESCRIPTION

Type of Description

within waveform  
between waveforms  
within random process  
between random processes

Dimension of Descriptions (Instantaneous Structure)

amplitude	]	translation
velocity		
acceleration		
higher derivatives of amplitude		
frequency	]	rotation
angular velocity		
derivatives of angular velocity		
time (Random process)		

Features and Events

peaks  
zero's  
positives and negatives  
begin and end  
maximum and minimum

Temporal Structure

spatial structure  
order-syntactic structure  
non-stationary structure

Occurrence Relationships

elementary occupance  
statistical  
transformational  
functional  
joint  
combined  
(Inter waveform)

5. Joint or Multiple Relationship is the application of any previously mentioned classification scheme to the joint occurrence along two or more of the fundamental dimensions of state.

6. A Combined Relationship is a combination of classification schemes. Within the relative time interval of the Temporal Structure, the Elementary Occurance and Statistical Schemes are mutually incompatible, although the latter may be derived from the former. With this exception the remaining combinations are applicable to each component of the Temporal Structure. At this juncture, before proceeding to a more detailed review of occurrence relationships and for completeness, it is well to mention the need to relate patterns of state which occur:

- a) between waveforms;
- b) within random processes;
- c) between random processes.

The effect of this enlargement to the field of study is to add an INTER class to the list of occurrence relationships and one new dimension - the PROCESS dimension to the instantaneous structure. The dimension labelled process applies only to the description of random processes.

With this addition, the ambit to waveform description is complete.

Table I is a checklist which summarises the full set of considerations relevant to the description of patterns of occurrence. It is apparent from this list that the number of combinations of Dimension, Feature, Temporal Structure and Occurrence Relationship is very large. If the set of relationships in each category of occurrence relationship is added to this list the number of combinations of different description become almost endless. For this reason it is clear that complete description of a

random waveform is a concrete unreality. In any waveform study the extent to which one need go can only be established with reference to the objectives of the study. It is likely that the objectives, including the time and cost objectives, as well as the task objective, will provide some practical and intellectually satisfactory criteria which may be used both to select the most appropriate descriptions and to limit their number. When the task objective is to discover a relationship between the pattern of occurrence in the waveform and some external state or condition, as it is in Neuropsychology Research and to some extent in Ergonomics Research there is an essential lack of such criteria and one is left to search and peck amongst the alternatives for a revealing description. It is, therefore, essential in this study to at least indicate what the alternatives are and the Checklist in Table I goes a long way in this direction. To add to this, details are given of the basic occurrence relationships applicable to all dimensions (but not all features). To add further to the list but also to limit, by experience, the zone of search and peck, a selection of occurrence relationships specific to each component of the Temporal Structure is detailed both in method and implementation with examples.

#### 4.2 Basic Occurrence Relationships

##### 1. Elementary occurrence

This measures the occupation time  $t_w$  of the waveform in some window or interval of scale  $(D + W/2) - (D - W/2)$  relative to the time interval  $T$  seconds.  $D$  being the magnitude of scale which locates the interval on the scale



where  $0 \leq t_w \leq 1.0$  and  $\Delta t_w$  are the intervals of time spent by the waveform in occupation of the scale interval  $(D + W/2) - (D - W/2)$ .

The method requires a means of generating and locating a sensitive window and a means of counting the time when it is occupied during the interval T seconds. If the waveforms are available in electrical form, as most are, the elementary occupancy method may be accomplished electronically. Whatever the means, whether analog or digital, once it is available it is applicable to all categories in Table I except descriptions between waveforms and random process. For these and for the classification of Joint occurrence between dimensions the method requires further complication in the form of additional windows - one for every additional scale and a system of logic to detect when all windows are simultaneously occupied. The general Joint Occupance Relationship is:

$$t_{w_n} = \frac{1}{T} \int_0^T \Delta t(w_1, w_2, \dots, w_n) dt \quad (27)$$

where  $0 \leq t_{w_n} \leq 1.0$

and  $\Delta t(w_1, w_2, \dots, w_n)$  are the intervals of time spent by the waveform in simultaneous occupation of the set of windows  $(w_1, w_2, \dots, w_n)$ .

An alternative to the window method is to measure the time spent by the waveform in excess of some threshold value D. The threshold really has no advantage over the window method since each may be derived from the other, i.e.

$$t_D = \int_0^D t_w dD \quad (28)$$

and

$$t_w = \int_{D - \frac{W}{2}}^{D + \frac{W}{2}} t_D dD \quad (29)$$

where  $D$  is the threshold value of some dimension  $D$  and  $t_D$  is the relative time spent in excess of the threshold  $D$ . The choice of method, therefore, is usually left to technical expedience.

When a contiguous set of windows span the range of magnitude of a dimension, the time spent in each window should sum to 1.0 indicating full knowledge of occupation and occurrence. When this happens the histogram which may be drawn is a TOTAL OCCUPANCE HISTOGRAM and the interval of this histogram within which the waveform spends most time is the MODE INTERVAL. The MEDIAN value of the MODE INTERVAL being the MODE VALUE of the pattern of occurrence. The smoothed version of a Total Occupance Histogram is referred to as a DISTRIBUTION.

## 2. Statistical Relationships

The statistical relations are all well known and were covered in some detail in Reference 2. They are mentioned here for the sake of completeness. Any relationship is a candidate for this category if it is a single number which expresses quantitatively some pervasive quality of the pattern of occurrence. Relationships which fulfil this criterion are averages with respect to time relative to some dimension of the pattern in Table I but not Features or Events.

The first relationship in this category is the INTEGRAL of a dimension with respect to time, DEFINITE to the relative time interval  $T$  seconds,

i.e. 
$$\text{INTEGRAL} = \int_0^T D(t) dt \quad (30)$$

where D is the magnitude of any dimension at the instant of time t seconds. The number resulting from this relationship is not a pervasive quality in the sense in which it has been defined. It is nevertheless included as a Statistical Relationship because it is directly related to the mean and is often used as a substitute for it. The other common Statistical Relationships are:

MEAN VALUE 
$$\bar{D} = \frac{1}{T} \int_0^T D(t) dt \quad (31)$$

MEAN SQUARE  
VALUE 
$$\bar{D}^2 = \frac{1}{T} \int_0^T D^2(t) dt \quad (32)$$

ROOT MEAN SQUARE  
VALUE 
$$[\bar{D}^2]^{\frac{1}{2}} = \left\{ \frac{1}{T} \int_0^T D^2(t) dt \right\}^{\frac{1}{2}} \quad (33)$$

VARIANCE 
$$\sigma_D^2 = \frac{1}{T} \int_0^T (D(t) - \text{MEAN VALUE})^2 dt \quad (34)$$

STANDARD DEVIATION 
$$\sigma_D = [\sigma_D^2]^{\frac{1}{2}} \quad (35)$$

Three of the relationships are linked by the equation

$$\text{MEAN SQUARE VALUE} = \text{VARIANCE} + \left[ \frac{\text{MEAN}}{\text{VALUE}} \right]^2 \quad (36)$$

The variance value is the second moment about the mean. Higher moments of general order  $n$  may be calculated according to the expression

$$\text{MOMENT} \quad M^n = \frac{1}{T} \int_0^T (D(t) - \bar{D})^n dt \quad (37)$$

Digressing for a moment (with apologies for the humour), it is worthwhile to remember when using any moment of second order and higher, that the pattern of occurrence has been subject to a process of weighting. The result is that the higher the order of moment the more attention is being paid in the STATISTIC to large excursions in the pattern relative to the mean value. There is also a difference in the quality of description between odd and even moments. All the odd moments are 'mean like' because the pattern of occurrence is not rectified (rectification is equivalent to the mathematical modulus  $|D(t)|$  or absolute value). Even moments rectify the waveform and have the added effect of doubling its frequency. For the non-stationary structure the behaviour of the odd and even moments provide a revealing description of change in the pattern of occurrence. When combined with the Elementary Occurance class, moments may be used to describe the qualities of SKEWNESS and KURTOSIS in the Total Occurance Histogram (Distribution). There are several definitions of the former quality and both qualities become rather meaningless if the shape of the Histogram is multi-modal. The most frequently used definition of Skewness is that due to Pearson. It is

$$\text{SKEWNESS} = \frac{\text{MEAN} - \text{MODE}}{\text{STANDARD DEVIATION}} \quad (38)$$

Kurtosis is the quality of peakedness or flatness of a histogram. It is the ratio of the fourth moment about the mean to the square of the second moment - the variance. Thus:

$$\text{KURTOSIS} = \frac{\frac{1}{T} \int_0^T (D(t) - \bar{D})^4 dt}{(\sigma_D^2)^2} = \frac{M^4}{(\sigma_D^2)^2} \quad (39)$$

All Statistical Relationships in this list may be calculated indirectly and approximately by taking moments of the Elementary Occurance Histogram, e.g.

$$\text{VARIANCE} = \frac{1}{N} \sum_{i=1}^n t w_i (D_i - \bar{D})^2 \quad (40)$$

where  $D_i$  is the magnitude of the dimension from the origin to the median of the window.  $\bar{D}$  is the mean value and N the number of windows.

This completes the list of SINGULAR Statistical Relationships. For more than one dimension WITHIN a waveform and for Statistical Occurance Relationships BETWEEN waveforms it is necessary to use Statistical relationships which describe pervasive qualities which occur jointly. For a pair of dimensions on a pair of waveforms the simplest joint statistic is COVARIANCE. Thus

$$\sigma_{12}^2 = \frac{1}{T} \int_0^T [D_1(t) - \bar{D}_1][D_2(t) - \bar{D}_2] dt \quad (41)$$

where  $\bar{D}_1$  and  $\bar{D}_2$  are the mean values of the two dimensions on waveforms under examination. The Covariance Statistic is a crude measure of relatedness and should not be used BETWEEN waveforms where it is known that time or frequency delays exist between the pattern of occurrence. If the two patterns of occurrence have nothing in common with one another, the Covariance value should be zero. The Covariance value is the first product moment about the mean of the two patterns. As with the singular case higher order moments may be computed to which the earlier remarks about weighting have equal application. The higher order product moment relationships are:

$$M_{12}^n = \frac{1}{T} \int_0^T [D_1(t) - \bar{D}_1]^n [D_2(t) - \bar{D}_2]^n dt. \quad (42)$$

The first product moment Correlation Coefficient is the Covariance value divided by (i.e. normalised) the product of standard deviation in each pattern, i.e.

$$r_{12} = \frac{\sigma_{12}^2}{\sigma_1 \sigma_2}. \quad (43)$$

where  $-1 \leq r_{12} \leq +1$ .

Introduction of the Correlation Coefficient is now beginning to overlap with the FUNCTIONAL class of relationship because its interpretation requires the assumption to be made that a LINEAR REGRESSION relationship, i.e.

$$D_2 = a D_1 + b. \quad (44)$$

exists between the pattern of occurrence,  $r_{12}$  is thus a measure of the degree to which the patterns are linearly related. Thus a zero product moment correlation coefficient does not mean that there is no correlation between the patterns. It is possible for there to be a high degree of non-linear correlation.

The subject of non-linear correlation which is a major concern with Biological waveforms is dealt with more appropriately in the section on Functional Relationships.

In a manner similar to the singular case, the JOINT STATISTICS may be calculated by taking product moments of the Joint Elementary Occupation Histogram, e.g.

$$r_{12} = \frac{\sum_{i=1}^N \sum_{j=1}^K t_{(W_1, W_2) i, j} (D_1 i - \bar{D}_1)(D_2 j - \bar{D}_2)}{\left[ \left( \sum_{i=1}^N D_1^2 i \cdot t_{(W_1) i} \right) \left( \sum_{j=1}^K D_2^2 j \cdot t_{(W_2) j} \right) \right]^{1/2}} \quad (45)$$

where  $t_{(W_1, W_2) i, j}$ , is the relative time spent by the dimensions on waveforms  $D_1$  and  $D_2$  in simultaneous occupation of the windows  $W_1$  and  $W_2$  located at the median distance  $i$  and  $j$  respectively from the origin of each dimension.

At this point it is proposed to go no further with the list of Statistical Relationships. As always, for multiple relationships, the expression becomes very complicated and matrix methods need to be introduced. Since, however, only paired comparisons are exemplified in the second part of this study and no formal matrix methods were used, it seems fair to stop at this point.

#### Moving Average

It is expedient for description of the Non-Stationary Structure to use a moving rather than a fixed averaging scheme. In the moving method the same relative time interval is used but a new average is calculated continuously as the TIME WINDOW is moved along the waveform. For a waveform of total length  $L$  seconds where  $L \gg T$  the result is a new waveform

an average waveform relative to the window T which starts at  $t = T$  seconds and which ends at L seconds. For  $t < T$  seconds the non-stationary statistic is not defined. For  $t > T$  seconds it is:

$$\text{MOVING MEAN} = \overline{D(T, \tau)} = \frac{1}{T} \int_0^{T+\tau} D(t) dt. \quad (46)$$

for  $0 \leq \tau \leq (L-T)$  secs.

where  $\tau = (t - T)$  for  $t \geq T$ .

and  $D(t)$  is the magnitude of any dimension in Table I at the instant t seconds.

Although it is applied here to measurement of movement of the mean value, the method is applicable to all Statistical Relationships listed in this section and any others not defined in this section. In this study the method has been applied to the Root Mean Square Value, but the approximation of a time weighted average was used. In this approximation as the front of the TIME WINDOW is moved along the waveform it trails behind it an exponential function which is multiplied by the waveform over which the moving window has already past. The product at all times from the front of the window backward to the start of the waveform is integrated and the result therefore places more emphasis on the pattern at the front of the window and exponentially less away from it. In effect the mechanism is a leaking integrator and this is exactly how it is implemented in practice by applying the analog waveform to a leaking capacitor or so called R.C. Low Pass Filter, i.e.

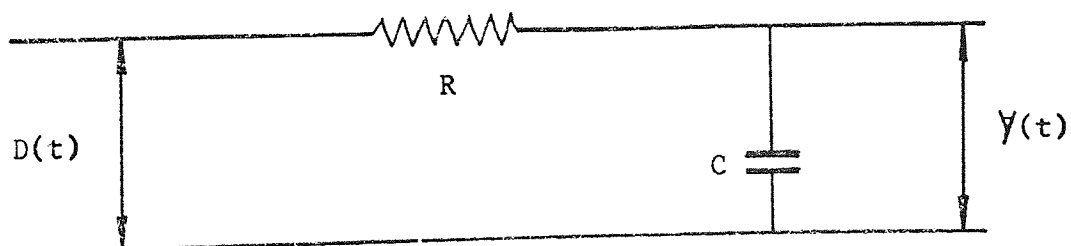



$$Y(t) = \frac{1}{RC} \int_0^{\tau} D(t) e^{-(\tau-t)/RC} dt \quad (47)$$

where  $\tau$  is the position of the front of the window in the waveform at any instant of time and  $0 \leq \tau \leq L$ .

In this analog technique the relative time interval of the window may be specified with reference to the time constant  $RC$  of the low pass filter. In reference 4 page 281, and in Bendat and Piersol (1966), page 243 details are given which relate the  $RC$  time constant to the true relative time interval  $T$ . It is shown that there is a good correspondence when:

$$T = 2 RC \text{ secs.} \quad 0 \quad (48)$$

### 3. TRANSFORMATION RELATIONSHIP

A Transformation Relationship, as it has been defined, is the result of an operation on the pattern of occurrence which is specified on a SCALE EXTRINSIC to the translational and time scales of the waveform. To commute the waveform in this way the pattern of occurrence must be related to some external phenomenon whose quality is conceptually different to any contained in the measured waveform. Any operation on a waveform, with the exception of PERMUTATION, whose result is specified on the INTRINSIC scales of the waveform we shall include in the class of Functional Relationships as an Analytical or Transfer Function Relationship. Such an operation was that exemplified in the last section by the  $RC$  low pass filter which strictly speaking results in a Transfer Function Relationship with a waveform.

## ORTHOGONAL RELATIONSHIPS

Few mathematical relationships appear to conform to this definition. Those that do relate a waveform to a set of ORTHOGONAL WAVEFORMS (templates) resulting in a scale of frequency, with real and imaginary components calculated to give a best fit. In theory there is no limit to the shape of waveforms that may form the basis of an orthogonal transformation. It must be deterministic and periodic but not necessarily simple harmonic. As well as the SINE wave, the SQUARE, TRIANGULAR, SAWTOOTH, CIRCULAR, PULSE and any other wave may be used as the ORTHOGONAL template so long as it is cyclic and the cycle time variable over a wide range. It is conventional in orthogonal transformation to relate the waveform and template by the 1st product moment statistic but there is no reason, in theory, which prevents any of the other joint statistics from being used including correlation based upon non-linear regression. However, for the purpose of decomposition and reconstruction and for reasons of speed and simplicity the product moment relationship is probably optimum.

The waveform commonly used in orthogonal transformation is the sine wave, which is the basis of the Fourier and Laplace transform. The square and a step wave are used in the HADAMARD or WALSH Transform, WALSH (1923) and HAAR transform, HAAR (1944). The HADAMARD and HAAR transforms in fact are just two out of a family of orthogonal transformations which result from vector matrix multiplication and factorisation of the decomposition matrix into a set of kronecker product matrices. A description of this family and the properties of each orthogonal transformation is given by Andrews (1969) who has also developed an algorithm for their computation. A fast version of the Hadamard transform is given by Whechel and Guinn (1968). Those who have used these more unusual transforms, it seems, have done

so more for computational efficiency and because they appear to offer a more compact but equally revealing description compared to the Fourier transform. For this reason they appeal to the pattern recognition specialist bent on optimum data reduction (or as they call it, feature extraction) of a waveform, an application which both Andrews and Whechel and Guinn describe in their papers.

Whilst on the subject of matrix methods it is as well to mention PRINCIPAL COMPONENT analysis which can provide a very compact description of a multi-dimensional pattern of occurrence Rao (1964). Principal Component analysis also uses a set of Orthogonal Functions to represent a pattern of occurrence. The result of the representation is a set of characteristic vectors and characteristic values known as Eigenvectors and Eigenvalues which correspond in Stochastic theory to the Karhunen - Loeve expansion of a random process. In the expansion the vectors and their values (which correspond to the frequency and amplitude of the Fourier coefficient) are chosen so that added together they give the best estimate of the Mean Square Statistic of the multidimensional pattern rather than the co-ordinates of an instantaneous occurrence.

#### PERMUTATION RELATIONSHIPS

A permutation relationship is determined by the number of even or odd transposition permutations required to re-arrange the pattern in one waveform so that it achieves a maximum of some measure of relatedness, with another waveform. The relationship is then specified by the maximising number of permutations  $J$  and by the degree of relatedness  $R_{xy}(J)$  which is maximum at that number of permutations. If the measure of relatedness is the product moment statistic then:

$$R_{xy}(J) = \left( \frac{1}{N} \sum_{i=1}^N x_i(P_j).y_i \right)_{\text{MAX}} \quad (49)$$

where  $P_j$  is the  $j^{\text{th}}$   $N \times N$  transposition permutation which maximises the product moment  $R_{xy}(j)$ .

As with matrices the method is implementable only on a digital computer. The possible number of re-arrangements of  $N$  numbers is  $N$  factorial, consequently for large  $N$  the iteration can become prohibitively time consuming and it is necessary to use a short relative time interval. As with Statistical Relationships the method may be implemented as a contiguous or moving window scheme and consideration should be given to the removal of gross time delays between waveforms before commencement of the permutation process. Either alone, or in series with crosscorrelation analysis, the Permutation Relationship is probably the most extreme form of non-linear relationship. The Permutation Relationship, as it has been defined, appears to be novel, consequently there are no examples of such a relationship having been used.

#### 4. FUNCTIONAL RELATIONSHIPS

The number of existing relationships, which fall into this category is very large. Consequently it has been necessary to select just a few which are known to have been used and which seem particularly relevant to the range of objectives associated with waveforms studies. For the purpose of exposition the 'Functionals' will be separated into two categories, a

DESCRIPTIVE and a TRANSFER FUNCTION class. The distinction between these categories is quite clear. A Descriptive Functional is the mathematical or probabilistic LINK between the magnitude of occurrence along two or more scales based upon either the ACTUAL occurrence or a description of that occurrence, e.g. an Elementary Occupance Description. A Transfer Function refers to an OPERATION which one waveform has undergone to produce another waveform. A Transfer Function may be INDUCED as in the case of the RC low pass filter in Section 2 or it may be DEDUCED from the pattern of occurrence between waveforms. In this section we shall deal only with relationships for the deduction of Transfer Functions. Relationships in both categories are for random waveforms.

#### DESCRIPTIVE FUNCTIONALS

It was stated that there are no TIME FUNCTIONALS for a random waveform. All the functions in this category are therefore based upon aggregate properties of the waveform, the simplest of which is given by the Elementary Occupance Histogram. To fit a smooth curve to an Occupance Histogram a variety of methods may be used, the most general of which was that proposed by Pearson (1894, 1901). An Elementary Occupance Histogram is a graph with the scale of the dimension on the abscissa and the relative time spent by the waveform in the occupance interval, plotted on the ordinate. To apply the Pearson technique it is necessary to imagine that the relative time spent in the occupance interval is a probability density measure. The Pearson family of curves which may be fitted to a histogram are based upon the limiting case of the hypergeometric series given by the differential equation.

$$\frac{d p(x)}{dx} = \frac{x - C_1}{C_0 + C_1 x + C_2 x^2} \cdot p(x) \quad (50)$$

where  $x$  is the scale magnitude and  $p(x)$  its probability density value. The Constants  $C_0, C_1, C_2$  are based upon moments of  $x$  about the mean of the histogram  $\bar{x}$ . For a detailed discussion of this technique and a worked example please refer to Reference 2 page 99. In addition to its use as a curve fitting routine the Pearson Generalised Probability Density Function is a useful tool for specifying the confidence limits of a pattern of occurrence with a skew-uni-modal distribution. A comprehensive list of Hypergeometric functions is given by Deutsch (1962). Derivations in terms of the Generalised Hypergeometric Function are given for some 43 functions including the Exponential, Binomial, Bessel, Incomplete Gamma, Error, Laguerre polynomial, Hermite and some of the more familiar functions such as the Arcsin, Arctan and Elliptic integrals.

#### NON-LINEAR REGRESSION

If it is apparent from a scattergram that a curved relationship exists between two dimensions or waveforms, the simplest way to obtain a functional relationship for this curve is to express one of the variables as a POLYNOMIAL in the other  
i.e.

$$D_2 = b_0 + b_1 D_1 + b_2 D_1^2 + \dots + b_k D_1^k \quad (51)$$

in which the coefficients  $b_i$  are constants and  $k$  is the degree of the Polynomial. If there are  $n$  distinct points on the curve then the curve may be made to pass through all of them by choosing  $k = (n - 1)$  but to minimise the calculation  $k$  should be small, say less than 5. The coefficients  $b_i$  are calculated by the method of least squares. The goodness of fit or correlation coefficient of such a curve to the Joint Occurrence Histogram is calculated as the ratio of occurrence explained by the polynomial to the

total occupance so that:

INDEX OF  
CORRELATION

$$r_I = \sum_{i=1}^n \left[ \frac{t_{(w_1, w_2) i, j \text{ EQUA}} \cdot (D_{2 \text{ EQUA}} - \bar{D}_2)^2}{\sum_{j=1}^n t_{(w_1, w_2) i, j} \cdot (D_{2j} - \bar{D}_2)^2} \right] \quad (52)$$

where  $t_{(w_1, w_2) i, j \text{ EQUA}}$  is the amount of time spent by the waveform in the intervals  $w_1$  and  $w_2$  located at the  $i$ th contiguity on scale  $D$ , and the location  $j \text{ EQUA}$  on scale  $D_2$ . The location  $j \text{ EQUA}$  is the interval which contains the distance  $D_2 \text{ EQUA}$  from the origin which is calculated from the polynomial equations.

Polynomial regression has been implemented in this study as part of a non-linear cross spectrum analysis programme, details of which are given in the next section of this chapter. There are other non-linear regressions to choose from such as the log function, and they are well documented in most statistical texts. Sometimes it happens that the patterns of occurrence in a scattergram appear to cluster, if they do, it may be appropriate to consider some of the discriminant or potential functions used in pattern recognition, Batchelor (1968).

#### TRANSFER FUNCTIONALS

A Transfer Function is the specification of an intervening process or operation between waveforms. It is most easily conceived in the context of an INPUT/OUTPUT SYSTEM where one waveform is an INPUT to the system, the other an OUTPUT and the TRANSFER FUNCTION the system characteristic.

Within this framework the objective of any waveform study may be specified according to whether it is the Input, System or Output which it is proposed to deduce from knowledge of the other two. Even without full knowledge it is possible to proceed with both theoretical and practical studies on the basis of knowledge of just one member of the tripartite with assumptions made about another. Rarely, however, are assumptions made about the output, it is usually the input which is assumed and in practice, almost always assumptions have to be made about the system e.g. about its linearity and time invariance. When it is the Transfer Function which is deduced from the other two, the deduction may be interpreted as an explanation of the joint occurrence relationship between the input and output waveforms. The general relationship for an Input/Output system is simply:

$$(\text{INPUT WAVEFORM}) \times (\text{SYSTEM TRANSFER FUNCTION}) = \text{OUTPUT WAVEFORM} \quad (53)$$

If a system is linear the behaviour of the system may be specified uniquely in the time domain by its IMPULSE RESPONSE FUNCTION or by its FREQUENCY RESPONSE FUNCTION in the frequency domain. The former specification is given by the response of the system to an impulse that in theory has infinite amplitude and infinitesimal duration, the latter by the response to a discrete frequency or sine wave. In the time domain the Output waveform is the CONVOLUTION of the INPUT waveform with the IMPULSE RESPONSE function. In the frequency domain, the Output Spectrum is the product of the Amplitude frequency response with the Amplitude Spectrum of the Input waveform and the sum of the Phase frequency response with the Phase Spectrum of the Input waveform.



Mathematically:

IN THE TIME  
DOMAIN

$$y(t) = \int_0^t h(\tau) x(t-\tau) d\tau. \quad (54)$$

IN THE FREQUENCY  
DOMAIN

$$Y(f) = H(f) X(f). \quad (55)$$

where  $h(\tau)$  is the impulse response function of the system and  $y(t)$  is the response amplitude of the system at time  $t$  to an input amplitude  $\tau$  seconds in the past. The integral is called the Convolution Integral, note that it is a backward looking integral because time  $\tau$  is measured from the present backwards to the start of the waveform. If you do not understand this integral, imagine that you have just hit your thumb with a hammer. Initially there is a slight delay and then a rapid build up in pain which has a lasting effect. After the worst has passed the pain slowly decreases, but the persistence of the pain will depend upon the severity of the blow. Eventually, however, there will come a time when the pain has completely disappeared but imagine that you again hit your thumb before the effects of the first blow have disappeared. You will add to your misery and the cycle of rising pain and gradual decay will start all over again. A few seconds later we can say that the degree of pain is due to the remnant of the first blow plus the remnant of the second blow. This sum is the Convolution Integral and the profile of pain which you experience from the instant the hammer contacts your thumb to a time in the future, when the pain has disappeared, is the Impulse Response

function of your thumb-sensory-perceptual system. If your thumb and associated transmission and perceptual system is a linear system then no matter what the severity of blow ( $x$  in the equation) the pain profile will always have the same shape but enlarged or contracted accordingly.

The Convolution Integral asks you to imagine that a waveform is a sequence of such hammer blows - one for each elementary transition of state, further complicated by the possibility of a negative blow to cater for negative values of the waveform (equivalent to a shot of cocaine in the thumb). At an instant of time during application of the waveform the state of the system is the sum of the remnant effects of all the blows that have been struck right back to the point in the waveform when it was initially applied to the system plus the response due to the present blow where it is understood that a blow in the analogy is the instantaneous amplitude in the actual waveform.

Notice however that the Convolution Integral is more than just the sum of the remnants at an instant of time. It is the sum or SUPERPOSITION of the Impulse Response generated by each Elementary Transition in the state of the waveform from time "t" right back to the point in the Input waveform when it was initially applied to the system. This adding together of Elementary Impulse Responses to determine an instantaneous Output amplitude is referred to as the SUPERPOSITION PRINCIPLE of Linear Systems. It is not a valid operation for time varying or non-linear systems.

In the other equation,  $X(f)$  and  $Y(f)$  are the Fourier transforms of the

Input and Output waveform and  $H(f)$  is the complex Frequency Response Function.

i.e.

$$H(f) = |H(f)| e^{-j\phi(f)} \quad (56)$$

where  $|H(f)|$  is the system GAIN factor and  $\phi(f)$  its PHASE factor.

Perhaps not surprisingly  $H(f)$  and  $h(\tau)$  are Fourier Transform pairs,

i.e.

$$H(f) = \int_0^{T_\tau} h(\tau) e^{-2\pi f\tau} d\tau \quad (57)$$

where  $T_\tau$  is the length of the Impulse Response Function.

Before going deeper into the ways and means for specifying Transfer Functions and the pro's and con's of Impulse Response versus Frequency Response it is well to consider how the pattern of occurrence between the Input and Output waveforms will differ as a result of the Linear System Operation and how this difference is revealed by the Transfer Function.

Given an Input and an Output waveform to observe side by side, the detailed identity of the system which connects them is not patent from the observed difference between their patterns of occurrence, although most linear systems do have a recognisable smoothing effect on the input waveform. The reason why the identity is not clear is that the input waveform, even for the simplest of systems, has undergone a quite complex, but selective, process of distortion. The distortion is due to the combined effects on the input of time delays and amplification and/or attenuations which are

Phase Response & Time Delay Profile  
for a Critically Damped Second  
Order System

Figure 20

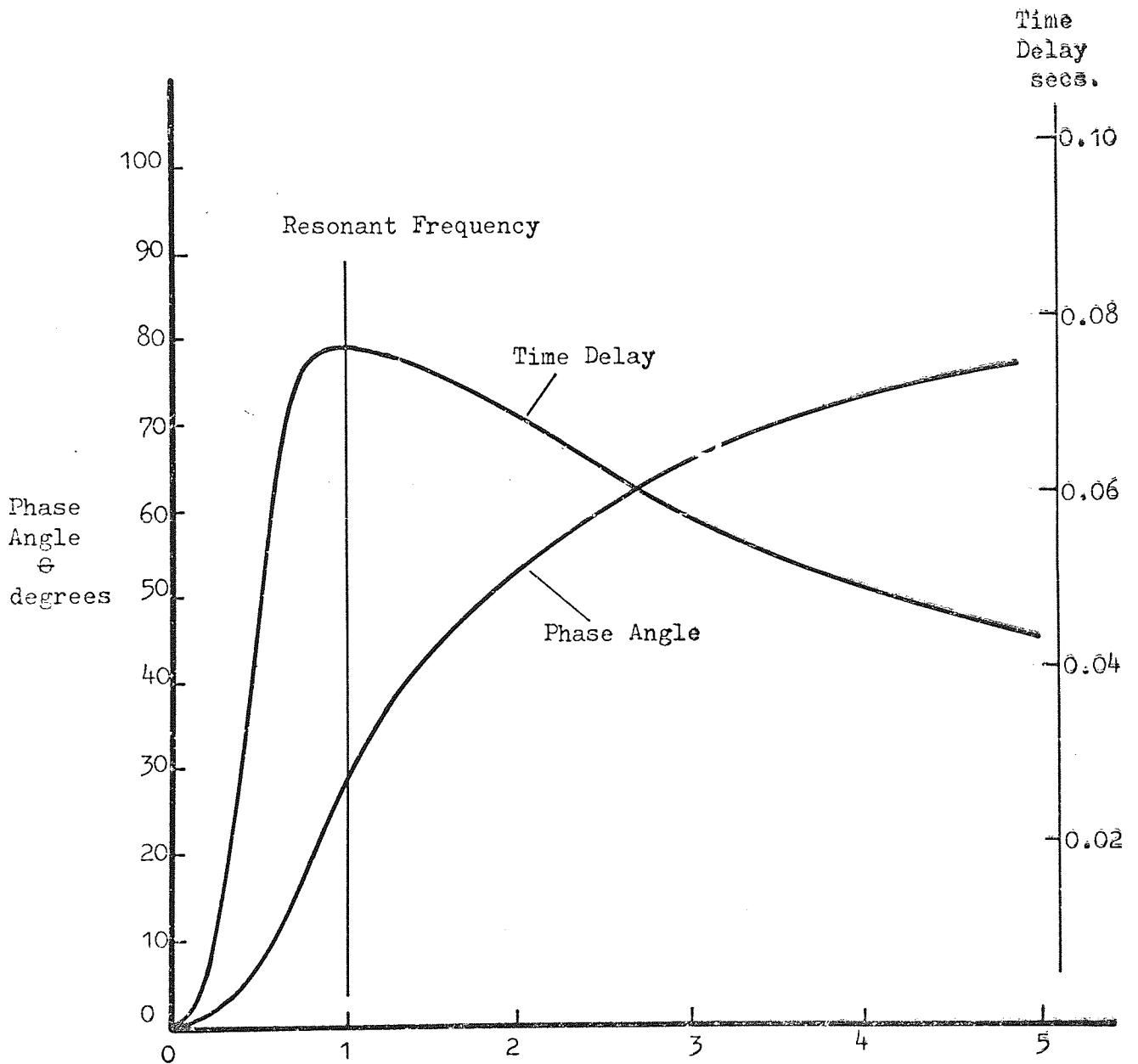

$$\frac{f}{f_0} - \text{ratio} = \frac{\text{Frequency } f \text{ in the Input Waveform}}{\text{Resonant Frequency of System}}$$

$$\text{Time Delay} = \frac{1}{360} \cdot \frac{d\theta}{df}$$

frequency selective in their effect. It is here that frequency takes on the physical importance which was mentioned in Chapter 3, because a system is linear in the sense of equation (55) and in no other sense. If a system is linear, a scattergram plotted between the filtered input and output waveforms should have perfect straight line regression if and when the concomitant time delay between them has been removed. In the Frequency domain, the process of selective distortion is clearly visible. The distortion due to time delays is revealed by the PHASE FACTOR <sup>part</sup> point of the Frequency Response Transfer Function,  $H(f)$  in equation (55), and the amplification/attenuation part by the GAIN FACTOR. For a linear system the pattern of distortion which these descriptions reveal is a highly non-linear, though systematic function of frequency. This is clear in Figure 20 which shows the PHASE part of the Frequency Response function for a second order linear system with critical damping. The profile is well known to most Engineers. The Phase Response profile has also been converted to a Time delay profile to show that maximum time delay for this type of linear system occurs at its resonant frequency i.e. 1.0 on the abscissa. The time delay at each frequency is just  $1/360$  th of the slope of the Phase response at that frequency, i.e.

$$\text{TIME DELAY } \tau(f) = \frac{1}{360} \cdot \frac{d\theta}{df} \quad (58)$$

where  $\theta$  is the phase angle and  $f$  a discrete frequency component in the input waveform. The Frequency Response description of a system is thus an explanation of the difference observed between the pattern of occurrence of an Input and Output waveform as well as being a description of the difference.

The Impulse Response Function.

Figure 21

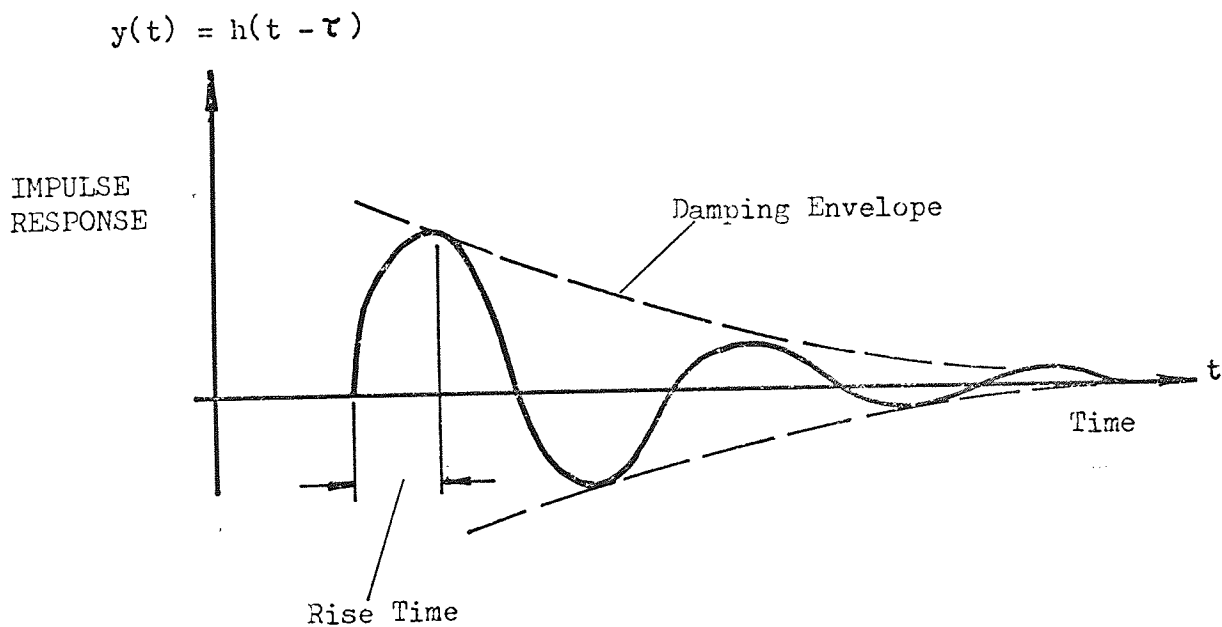
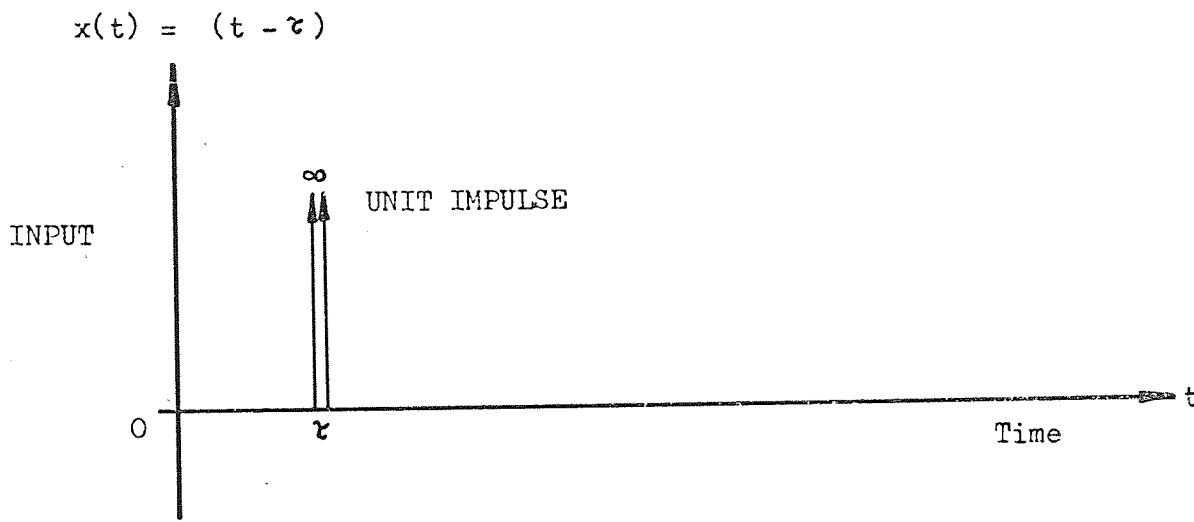

In the Impulse Response Function, the Frequency Sensitivity characteristic of the System, which is responsible for the observed difference, is not clearly visible, it is implied. It is therefore less of a visible explanation of the observed difference between Input/Output waveforms than the Frequency Response, but no less an objective explanation. Unlike Frequency Response, the system rise time is explicit in its display and the visible decay in the Impulse Response is a better qualitative indication of damping in the system than anything comparable in the Frequency Response. A typical Impulse Response of an underdamped second order linear system is shown in Figure 21. There are then, pro's and con's as far as the display is concerned and even more when one considers the experimental and analytical techniques required to specify the two Transfer Functions.

In the analytical technique the Transfer Function for a linear system is obtained from the solution to the equation of motion of the system, e.g. if the equation of motion is given by:

$$M \frac{d^2 y}{dt^2} + C \frac{dy}{dt} + ky = C \frac{dx}{dt} + kx \quad (59)$$

the system is a base excited second order linear system and its frequency response is the solution to this equation.

i.e.

$$|H(f)| = \frac{|y(f)|}{|x(f)|} = \left\{ \frac{1 + 2\zeta \cdot f/f_n}{(1 - [f/f_n]^2)^2 + 2\zeta \cdot f/f_n} \right\}^{1/2} \quad (60)$$

$$\phi(f) = \tan^{-1} y(f)/x(f). \quad (61)$$

$$\text{where } \zeta = C/2\sqrt{kM}. \quad (62)$$

$$\text{and } f_n = \frac{1}{2\pi} \sqrt{k/M}. \quad (63)$$

The Complete Scheme of Fourier Transformation for Input - Output Systems. ( After Anstey 1966) Figure 22

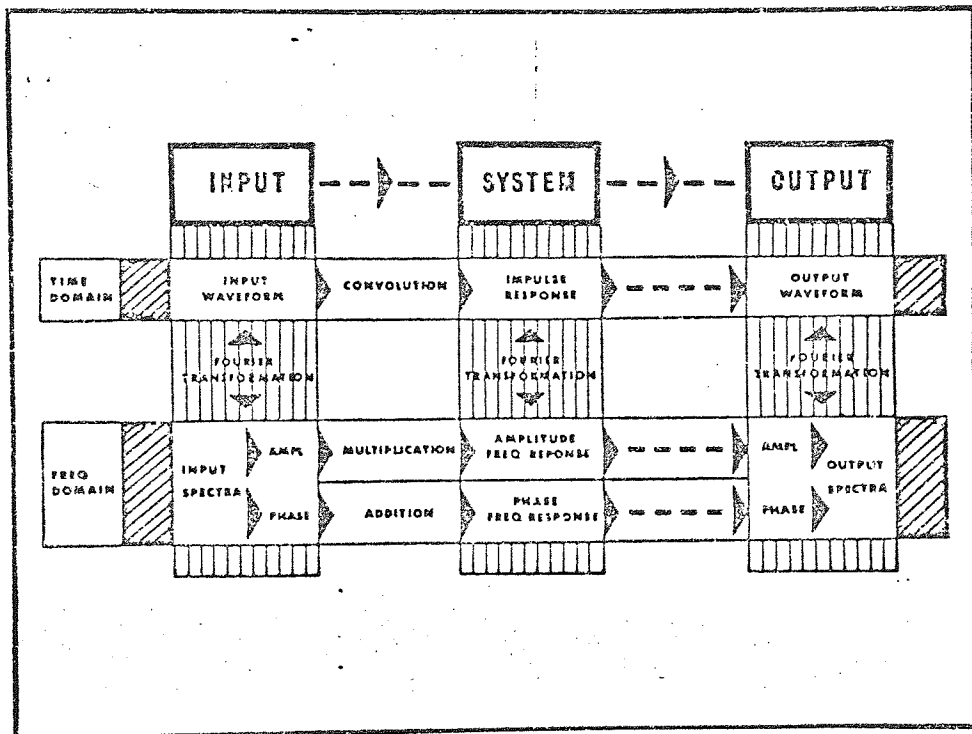



In these equations,  $x$  is the input and  $y$  the output waveform which is assumed to be sinusoidal and of frequency  $f$  c/s. In Reference 2, page 115 the derivation and solution to this equation of motion are given together with the resultant Frequency Response characteristic for various values of  $\xi$  and  $f_n$ . The Impulse Response Function is the solution to the same equation of motion where the input waveform  $x$  is an Impulse rather than a sine wave. The complete scheme for studying Input/Output systems is shown in Figure 22 which was taken from Anstey (1966) whose booklet entitled "Wiggles" is an excellent exposition, in words, of each element in Figure 22.

It is clear from Figure 22 why treatment of Input/Output systems in the time domain is unpopular amongst both practitioners and theorists. Compared to the straight product relationship in the Frequency domain the convolution relationship in the time domain is so much more difficult to manipulate. In addition in the experimental study of system transfer functions it is much more difficult to apply an impulse than a sine wave. For this set of reasons; namely the fact that the Impulse Response Function does not display the system Frequency Sensitivity characteristic which is perhaps the best visible explanation of the observable difference between Input/Output waveforms, the difficulty of implementing the Convolution Integral and Inverse Convolution compared to multiplication and division and the problem of applying a true impulse consistently to a system compared to the ease and precision with which it is possible to apply a sine wave make the Frequency Response Function the favourite Transfer Function.

In the study of Input/Output waveforms associated with Biological or

Behavioural processes, it is more appropriate to regard the Linear Transfer Function as a MODEL offering a simplified LINEARITY explanation (in the sense of equation (55)) for the difference between waveforms because Biological/Behavioural processes are all non-linear, Milsum (1966). There are perhaps no processes which are more non-linear, e.g. human behaviour is such that it is possible for the same input waveform applied at different times to engender a response ranging from nothing at all to a violent reaction. For such a process not one but a galaxy of models are required, plus a decision system for switching between them. Although it is clear that such animate processes violate the Superposition principle the Linear System Model is nevertheless a useful template for non-linear systems because we can use it to measure the degree of non-linearity. Such a measure is useful because it provides a criterion for choosing between other models to account for the difference between waveforms. In Part II in the section on manual control a variety of non-linear transfer function models are studied and in Deutsch (1966) there is a review of analytical non-linear Transfer Functions.

For random waveforms the Linear System model requires slight modification. In place of the Input and Output waveforms in (54) and the Amplitude Spectrums in the Fourier Transform (55), Correlation and Power Spectrum descriptions are used respectively. The definition of these descriptions conform to the Wiener/Khinchine relationship (20) but a more detailed definition is given in the section dealing with the Temporal Structure. For random waveforms (54) and (55) become:

$$R_{xy}(\tau) = \int_0^{\infty} h(v) R_x(\tau-v) dv. \quad (64)$$

and

$$G_{xy}(f) = H(f) G_x(f). \quad (65)$$

where  $V$  is the time axis of the Autocorrelation Function and  $\tau$  a specific time delay along that axis.  $R_x(\tau)$  and  $G_x(f)$  are the Autocorrelation and Power Spectral Density descriptions of the Input waveforms and  $R_{xy}(\tau)$  and  $G_{xy}(f)$  are the Cross-correlation and Cross Spectral Density descriptions between the Input and Output waveforms. As before, the Frequency Response Function for random waveforms can be broken down into a Gain and Phase Factor.

$$G_y(f) = |H(f)|^2 G_x(f) \quad (66)$$

$$\phi(f) = \tan^{-1} \frac{Q_{xy}(f)}{C_{xy}(f)} \quad (67)$$

here the phase factor  $\phi(f)$  has been expressed in terms of the Quadrature and Coherent Spectrum parts of the Cross Spectrum. For the moment these expressions will remain undefined and unexplained because they are dealt with in detail and implemented in the next section.

In passing it is worthwhile to mention a scheme which has been implemented by Fenwick and Fenton (1971) for identification of the Random Impulse Response Function in (64). Their scheme uses Autoregression analysis applied to a single output waveform where it is assumed that the Input waveform is a Gaussian Random variable. The method is like convolution in reverse. The present input magnitude  $Y(t)$  is specified in terms of the present output magnitude  $X(t)$  minus the weighted sum of all the outputs in the past.

$$\text{i.e. } Y(t) = X(t) - (a_1 X(t-1) + a_2 X(t-2) + \dots + a_p X(t-p)) \quad (68)$$

In the study of system dynamics, the Fokker-Plank equation offers a powerful alternative to the Transfer Function or method of Rice (1944), covered in Chapter 4. The Fokker-Plank equation, which belongs to Statistical Mechanics, Fokker (1913), Plank (1927), may be used to predict what will occur when a non-linear system is subject to a random disturbance. The predicted occurrence or response of the system is the solution to the Fokker-Plank equation which unlike the Frequency Response Equation cannot be transposed. From the solution one obtains for the dynamic system the transition probability density of the system state trajectory in phase space. For an 'n' degree of freedom system the state space is 2n dimensional and the probability density is  $P_{C2}(Y_1|Y_2,t)$  where  $Y_1$  is the position vector of a point in 'n' dimensional phase space at time zero and  $Y_2$  is the position vector of the point t seconds later. For a single degree of freedom system the phase space reduces to the phase plane and the probability density is  $P_{C2}(y, \dot{y}_1 | y_2, \dot{y}_2, t)$  where  $y$  and  $\dot{y}$  are respectively the amplitude and velocity of the system. First suggested by Andronov, Pontryagin and Vitt (1933), the approach has been used widely by physicists for the study of Brownian motion, Wang and Uhlenbeck (1945), for the study of random vibration of non-linear suspensions, Ariaratham (1960), electrical control systems Barrett (1958) and Chuang and Kazda (1959), vibration of non-linear structures, Crandall, Caughey and Lyon (1963) and there is reason to suspect that the method may be applicable to transmission of vibration through the human body. This latter possibility is studied in Part II and only the derivation of the equation is dealt with here, together with its solution for some continued systems.

To derive the Fokker-Plank equation it is necessary first to assume that each consecutive elementary transition of state in the random disturbance waveform is statistically independent. This is tantamount to the assumption of a Gaussian distribution for the random disturbance and it follows from this that the random displacements of the system will follow a Brownian or Markov stochastic process in phase space. A Markov process is one in which the present state of the process is dependent only upon the state of the process in the immediate past and upon no other state. A more precise definition is given by the conditional or transition probability of the process. If we define  $P_{c2}(Y_1 | Y_2, t)$  as the probability that for a given position  $Y_1$  of the state vector  $Y$  at time  $t=0$  we find in the range from  $Y_2$  to  $Y_2+dY_2$  at a time  $t$  seconds later, then we define the Markov process to mean that the conditional probability that  $y$  lies in the interval from  $Y_1$  to  $Y_1+dY_1$  at time  $t_1$ , from  $Y_2$  to  $Y_2+dY_2$  at time  $t_2$  - - - - from  $Y_{n-1}$  to  $Y_{n-1}+dY_{n-1}$  at  $t_{n-1}$  depends only upon the values of  $Y$  at  $t_n$  and  $t_{n-1}$ , i.e.

$$P_{cn}(Y_1, t_1, Y_2, t_2, \dots, Y_{n-1}, t_{n-1} | Y_n, t_n) = P_{c2}(Y_{n-1}, t_{n-1} | Y_n, t_n)$$

The conditional probability  $P_{c2}$  may be found from the relationship:

$$P_{c2}(Y_1 | Y_2, t) = \frac{P_2(Y_1, t_1, Y_2, t_2)}{P_1(Y_1, t_1)}$$

where  $t = t_2 - t_1$ .

must satisfy the conditions:

a)  $P_{c2}(Y_1 | Y_2, t) \geq 0$ .

b)  $\int_{-\infty}^{+\infty} P_{c2}(Y_1 | Y_2, t) dY_2 = 1$ .

c)  $P_1(Y_2, t_2) = \int_{-\infty}^{+\infty} P_1(Y_1, t_1) P_{c2}(Y_1 | Y_2, t_2 - t_1) dY_1$ .

$$d) P_{c2}(Y_1 | Y_2, t) = \int P_{c2}(Y_1 | Y\tau) P_{c2}(Y | Y_2, t - \tau) dY.$$

$$\text{for } 0 \leq \tau \leq t.$$

This last equation is referred to as the Smoluchowski (1916) equation. It implies that the transition probability in moving from  $Y_1$  at  $t_1$  to  $Y_2$  at  $t_2$  is independent of the particular path taken when moving between these terminal states. The Smoluchowski equation is the starting point for the derivation of the differential equation for the probability density  $P_{c2}(Y_1 | Y_2, t)$ .

Let  $Z$  correspond to the particular position  $Y$  of the space co-ordinate at any time in the intervening interval between  $Y_1$  and  $Y_2$ . Then the statistical moments of the change in the space co-ordinate in a small time increment  $\Delta t$  between  $t_1$  and  $t_2$  are the moments of the transition probability density at time  $t_1 + \Delta t$  about each co-ordinate value of the state vector at  $t_1$ . The total moment of change in the space co-ordinate is then

$$a_n(Y_1, \Delta t) = \int_{-\infty}^{+\infty} \int_{-\infty}^{+\infty} \dots \int_{-\infty}^{+\infty} (z_i - y_i)^n P_{c2}(Y_1 | Z, \Delta t) \prod_{i=1}^{2n} dz_i$$

2N FOLD

The derivation continues with the assumption that as  $\Delta t \rightarrow 0$  only the first and second moments become proportional to  $\Delta t$  so that in the limit the following moments exist.

$$a_i(Y_1, \Delta t) = \lim_{\Delta t \rightarrow 0} \frac{a_{1i}(Y_1, \Delta t)}{\Delta t}$$

$$\text{and } b_{ij}(Y_1, \Delta t) = \lim_{\Delta t \rightarrow 0} \frac{a_{2ij}(Y_1, \Delta t)}{\Delta t}.$$

In the Fokker-Plank method these two equations contain all the information about the system and its disturbance because they are calculated from the laws of motion of the system and the power spectrum of the disturbance.

To obtain a differential equation for the probability  $P_{c2}$  an arbitrary function  $R(Y)$  is introduced into the Smoluchowski equation as a scalar function of the space co-ordinates  $y_i$  such that  $R(Y) \rightarrow 0$  as all  $y_i \rightarrow \pm \infty$ . Writing  $X$  for  $Y_1$ ,  $Y$  for  $Y_2$  and retaining  $Z$  as any intervening state between  $X$  and  $Y$  at time  $t + \Delta t$ , introducing  $R(Y)$  and integrating over the whole of phase space, the Smoluchowski equation becomes

$$\int_{-\infty}^{+\infty} \int_{-\infty}^{+\infty} R(Y) P_{c2}(X|Y, t + \Delta t) \prod_{i=1}^{2n} dy_i$$

$$= \int_{-\infty}^{+\infty} \int_{-\infty}^{+\infty} \prod_{i=1}^{2n} dz_i \int_{-\infty}^{+\infty} \int_{-\infty}^{+\infty} R(Y) P_{c2}(X|Z, t) \cdot P_{c2}(Z|Y, \Delta t) \prod_{i=1}^{2n} dy_i$$

Developing  $R(Y)$  in a Taylor series in  $(y_i - z_i)$  as far as the second order to conform with the assumed limit on the statistical moment

$$R(Y) = R(Z) + \sum_{i=1}^{2n} (y_i - z_i) \frac{\partial R(Z)}{\partial z_i}$$

$$+ \frac{1}{2} \sum_{i=1}^{2n} \sum_{j=1}^{2n} (y_i - z_i)(y_j - z_j)$$

$$\times \frac{\partial^2 R(Z)}{\partial z_i \partial z_j} + o|Y - Z|^2$$

substituting for  $R(Y)$  and making use of the expression for the moments, the double integral on the R.H.S of equa ( ) becomes:

$$\int_{-\infty}^{+\infty} \int_{-\infty}^{+\infty} R(Z) P_{c2}(Z|Y, \Delta t) \prod_{i=1}^{2n} dz_i$$

$$\begin{aligned}
 & + \Delta t \int_{2^N \text{ FOLD}} \int \left[ \sum_i a_i(Y, \Delta t) \frac{\partial R(Z)}{\partial y_i \partial y_j} \right] P_{c_2}(Z|Y, \Delta t) \prod_{j=1}^{2N} dz_j \\
 & + \Delta t \int_{2^N \text{ FOLD}} \int \left[ \sum_i \sum_j \frac{1}{2} b_{ij}(Y, \Delta t) \frac{\partial^2 R(Z)}{\partial y_i \partial y_j} \right] P_{c_2}(Z|Y, \Delta t) \prod_{j=1}^{2N} dz_j \\
 & + o(|\Delta t|).
 \end{aligned}$$

Integrating by parts and writing  $Y$  for  $Z$ , equa ( ) becomes:

$$\begin{aligned}
 & \frac{1}{\Delta t} \int_{2^N \text{ FOLD}} \int R(Y) [P_{c_2}(X|Y, t + \Delta t) - P_{c_2}(X|Y, t)] \prod_{i=1}^{2N} dy_i \\
 & = \int_{2^N \text{ FOLD}} \int R(Y) \left[ - \sum_{i=1}^{2N} \frac{\partial}{\partial y_i} \left\{ a_i P_{c_2}(X|Y, t) \right\} \right. \\
 & \left. + \frac{1}{2} \sum_{i=1}^{2N} \sum_{j=1}^{2N} \frac{\partial^2}{\partial y_i \partial y_j} \left\{ b_{ij} P_{c_2}(X|Y, t) \right\} \right] \prod_{i=1}^{2N} dy_i + o(|\Delta t|).
 \end{aligned}$$

In the limit as  $\Delta t \rightarrow 0$ , gives

$$\begin{aligned}
 & \int_{2^N \text{ FOLD}} \int R(Y) \left[ \frac{\partial P_{c_2}(X|Y, t)}{\partial t} + \sum_{i=1}^{2N} \frac{\partial}{\partial y_i} \left[ a_i P_{c_2}(X|Y, t) \right] \right. \\
 & \left. - \frac{1}{2} \sum_{i=1}^{2N} \sum_{j=1}^{2N} \frac{\partial^2}{\partial y_i \partial y_j} \left[ b_{ij} P_{c_2}(X|Y, t) \right] \right] \prod_{i=1}^{2N} dy_i = 0.
 \end{aligned}$$

since this equation must hold for any function  $R(Y)$ , the contents of the bracket must be zero. This is the Fokker-Plank equation for an  $N$  degree of freedom system subject to a non-stationary Gaussian disturbance.



$$\frac{\partial P_{c_2}(X|Y, t)}{\partial t} = - \sum_{i=1}^{2N} \frac{\partial}{\partial y_i} [a_i P_{c_2}(X|Y, t)]$$

$$+ \frac{1}{2} \sum_{i=1}^{2N} \sum_{j=1}^{2N} \frac{\partial^2}{\partial y_i \partial y_j} [b_{ij} P_{c_2}(X|Y, t)]$$

If the random disturbance is Stationary to at least second order it is likely with the passage of time that the probability distribution  $P_{c_2}(X|Y, t)$  will tend towards an equally stationary distribution  $P(X)$  which is independent of the initial conditions of the system and unaffected by translation in time.

For a single degree of freedom system  $P(X) = P(x, \dot{x})$ . To obtain the Stationary form of the Fokker-Plank equation let  $\partial P_{c_2}(X|Y, t) / \partial t = 0$  and  $t \rightarrow 0$ , then:

$$\frac{1}{2} \sum_{i=1}^{2N} \sum_{j=1}^{2N} \frac{\partial^2}{\partial y_i \partial y_j} [b_{ij}(x) P(x)] - \sum_{i=1}^{2N} \frac{\partial}{\partial y_i} [a_i(x) P(x)] = 0.$$

#### EXAMPLE

The simplest specific example which may be used to illustrate the specific derivation and solution of the Fokker-Plank equation is that of a single degree of freedom - second order system having a linear damping characteristic but a non-linear stiffness. The law of motion of such a system is of the form

$$\ddot{x} + \beta \dot{x} + F(x) = F(t)$$

where  $F(x)$  is the non-linear restoring force per unit mass,  $\beta$  the damping force per unit mass and  $F(t)$  is the random disturbance per unit mass.

In order to obtain an exact solution to the subsequent Fokker-Plank equation for this system it is necessary to assume that the waveform of the random disturbance is a Stationary, Gaussian, White, random process, having a constant power spectral density value which we shall assume for the sake of convenience to be  $2G g^2/c/s$ /unit mass. For a random process constructed from such a variable the ensemble mean value is zero and the ensemble autocorrelation function closely approximated a Dirac delta function, i.e.

$$E_{\alpha} \{ [F(t)] \} = 0$$

$$E_{\alpha} \{ [f(t_1) \cdot f(t_2)] \} = 2G \delta(t_1 - t_2)$$

In order to obtain an expression for the displacement of the phase point along each co-ordinate in its phase space, the equation of motion in each co-ordinate is integrated over a short time interval  $\Delta t$ . For the single degree of freedom system the phase space is 2 dimensional. To obtain a law of motion for each dimension the second order equation of motion is reduced to two first order equations by letting  $x = x_1$  and  $\dot{x} = x_2$ .

Therefore,

$$\dot{x}_1 = x_2$$

$$\dot{x}_2 = -\beta x_2 - F(x_1) + F(t).$$

The displacements along each co-ordinate are then:

$$\frac{dx_1}{dt} \cdot \Delta t = \Delta x_1 = x_2 \Delta t.$$

$$\frac{dx_2}{dt} \cdot \Delta t = \Delta x_2 = -\beta x_2 \Delta t - F(x_1) \Delta t + \int_t^{t+\Delta t} f(t) dt.$$

To obtain the coefficient  $a_i$  and  $b_{ij}$  which appear in the Fokker-Plank equation an Ensemble average is obtained for the first and second moments of the displacements  $\Delta x_1$  and  $\Delta x_2$ , i.e.

$$a_1 = \lim_{\Delta t \rightarrow 0} \frac{E_{\alpha} \{(\Delta x_1)\}}{\Delta t} = \frac{E_{\alpha} \{(x_2 \Delta t)\}}{\Delta t} = x_2 = \bar{x}$$

$$a_2 = \lim_{\Delta t \rightarrow 0} \frac{1}{\Delta t} E_{\alpha} \left\{ (-\beta x_2 - F(x_1)) \Delta t + \int_t^{t+\Delta t} f(t) dt \right\}$$

By definition from equa ( )  $\int_t^{t+\Delta t} f(t) dt = 0$  for even

a small section of disturbance waveform

$$\therefore a_2 = -\beta x_2 - F(x_1) = -\beta \bar{x} - F(x).$$

$$b_{11} = \lim_{\Delta t \rightarrow 0} \frac{E_{\alpha} \{(\Delta x_1)^2\}}{\Delta t} = 0.$$

$$b_{12} = b_{21} = \lim_{\Delta t \rightarrow 0} \frac{E_{\alpha} \{(\Delta x_1 \cdot \Delta x_2)\}}{\Delta t} = 0.$$

because after amplification and division by the denominator  $\Delta t$ ,  $\Delta t$  remains in each term of the numerator. Hence in limit as  $\Delta t \rightarrow 0$  the numerator = 0.

$$\begin{aligned}
 b_{22} &= \lim_{\Delta t \rightarrow 0} \frac{E \{ (\Delta x_2)^2 \}}{\Delta t} \\
 &= \lim_{\Delta t \rightarrow 0} E \left\{ \left[ \left[ -\beta x_2 - F(x_1) \right]^2 \Delta t + 2 \left[ -\beta x^2 - F(x_1) \right] \right. \right. \\
 &\quad \left. \left. \times \int_t^{t+\Delta t} f(t) dt + \frac{1}{\Delta t} \int_t^{t+\Delta t} \int_t^{t+\Delta t} \left\{ f(t_1) f(t_2) dt_1 dt_2 \right\} \right] \right\}
 \end{aligned}$$

Clearly in the limit as  $\Delta t \rightarrow 0$  the first two terms go to zero, so that

$$b_{22} = \lim_{\Delta t \rightarrow 0} \frac{1}{\Delta t} \int_t^{t+\Delta t} \int_t^{t+\Delta t} E \{ f(t_1) f(t_2) \} dt_1 dt_2$$

$$b_{22} = \lim_{\Delta t \rightarrow 0} \frac{1}{\Delta t} \int_t^{t+\Delta t} \int_t^{t+\Delta t} 2G \delta(t_1 - t_2) dt_1 dt_2.$$

$$b_{22} = 2G.$$

substituting the coefficients  $a_i$  and  $b_{ij}$  into the stationary form of the Fokker-Plank equation gives the differential equation for the stationary probability density function  $P(x_1, x_2) = P(x, \tilde{x})$

$$G \frac{\partial^2 P(x, \tilde{x})}{\partial \tilde{x}^2} = \frac{\partial (\tilde{x} \cdot P(x, \tilde{x}))}{\partial x} + \frac{\partial ([+\beta \tilde{x} + F(x)] P(x, \tilde{x}))}{\partial \tilde{x}}$$

The solution to this equation has been obtained independently by Wang and Uhlenbeck (1945), Chuang and Kazda (1959) and Oliver and Win (1958).

It is

$$P(x, \dot{x}) = C \text{EXP} \left[ -\frac{\beta}{2G} \left( 2 \int_0^x F(x) dx + \dot{x}^2 \right) \right]$$

where C is a normalising constant.

G in this equation is the power spectral density of the disturbance, or stated another way, the variance of the disturbance per cycle per second. Using this interpretation of G, note that velocity is distributed Normally but that the displacement of the system is generally non-Gaussian due to the non-linearity. If  $P(x, \dot{x})$  is a single sharp peak in the neighbourhood of the origin  $x = \dot{x} = 0$  the system will spend most of its time in a state of equilibrium. It is clear from the solution that an increase in this probability may be accomplished by an increase in the damping factor or by the introduction of positive non-linearity, i.e. a hardening spring. This concludes the example.

In general, the analytical solution of the Fokker-Plank equation presents a very difficult problem as Ariaratnam (1960) has noted. For a two degree of freedom system it has been solved analytically by Ariaratnam (1960) but it is clear that for more complex systems having unusual non-linearities one must seek a numerical method of solution. In Part II an attempt has been made to do this for the transmission of vibration through the human body.

T A B L E I I

SHORT CHECKLIST OF BASIC OCCURRENCE RELATIONSHIPS

ELEMENTARY OCCUPANCE      Time spent by waveform in some interval of scale  
Distributions

STATISTICAL      Integral  
Mean  
Mean square  
Variance  
Runs/Standard deviation  
Moments  
Skewness/Kurtosis  
Co-variance  
Product moments  
Linear regression and correlation  
Moving averages

TRANSFORMATIONAL

Orthogonal Transforms

Fourier/Laplace  
Hadamard/Walsh  
Haar  
Principle components

Permutation Transforms

Product Moment Transposition Permutation

FUNCTIONAL

Descriptive Functionals

Pearson generalised probability density  
Polynomial, etc., Regression  
Discriminant/Potential functions

Transfer

Impulse response  
Frequency response  
Fokker-Plank equation (predictive only)

#### 4.3 Description of the Temporal Structure

In the preceding section a set of Occurrence Relationships have been specified which form the basis of the more specific relationships covered in this section. The set of basic relationships covered are listed in Table II and the set of more specific Temporal Relationships to be covered in this section are listed in Table III.

In the opening paragraph to this chapter it was postulated that the Temporal Structure of a waveform has a Spatial, an Order and a Non-stationary component. The list of relationships in Table III are the set of CLASSICAL descriptions which define these structural components. The list is not exhaustive because it does not cover all combinations of the entries in Table I and Table II. Nevertheless, the list is thought to be sufficiently comprehensive to cover the range of objectives which are met in waveform studies. The main aims of the section are:

- a) To review and to specify descriptions appropriate to each component of the Temporal Structure.
- b) To explain, where appropriate, what quality of the pattern of occurrence the descriptions reveal and to highlight any qualities which are not covered by the classical methods of waveform analysis.
- c) To comment upon the uniqueness problem in relation to the range of objectives associated with waveform studies.
- v d) To give details of the techniques used to implement the various descriptive schemes together with the set of considerations attached to each description and to compare the relative advantages of alternative techniques which provide similar descriptions for particular qualities of the pattern of occurrence.
- e) To comment upon the compatibility between the nature of Biological wave-

T A B L E . I I I

CHECKLIST OF OCCURRENCE RELATIONSHIPS FOR THE TEMPORAL STRUCTURE

SPATIAL STRUCTURE

WITHIN WAVEFORM

Singular Total occurrence histogram (probability density)  
of: Translatory Dimensions )  
Rotary Dimensions ) See Table I  
Features )  
Random Process Ensemble)

Plural Joint occurrence histogram between dimensions  
Power spectral density  
Auto correlation

BETWEEN WAVEFORMS

Joint occurrence histograms within/between  
dimensions between waveforms  
Cross spectral density  
Cross correlation  
Linear and non-linear system models  
Non linear Crosscorrelation

ORDER STRUCTURE

WITHIN WAVEFORM

Transition occurrence (probability density)  
histogram

BETWEEN WAVEFORM

Multiple transition occurrence histograms  
Permutation Relationships  
Fokker - Plank Equation

NON-STATIONARY STRUCTURE

Short time averages combined with moving averages  
Short time interval occurrence relationships  
Gabor transform  
Random process ensemble averages



forms and the quality of description provided by the set of classical descriptions.

f) To give some indication of the technical status of waveform analysis in terms of task and time capability and the cost of analysis.

The set of descriptive schemes which form the backbone of modern Random Waveform Theory will be referred to as the "Classical Descriptions" to distinguish them from some of the more novel, expedient and short-cut descriptions which are peculiar to particular fields of application. The 'classical' descriptions have their origin in a variety of theoretical and practical research areas. No one knows who, when or where waveforms were first used. They are probably as old as the process of formal thought and the Scientific method. Historically, the discovery of Fourier Series mark the starting point of theory germane to the description of waveforms. Fourier series date back to the first half of the 18th Century. They originated in problems of Mathematical Physics in connection with the problem of vibrating cords (Daniel, Bernoulli, Leonhard, Euler) but they take their name from the french mathematician and physicist Jean Baptiste Joseph Fourier (1768 - 1830) who based on them his mathematical theory of heat conduction "Theorie analytique de la chaleur" which was published in 1822. The sense in which they are used to describe a waveform is different to the sense in which they were used by Fourier and his predecessors. Their use for them was in the solution of boundary value problems in partial differential equations whereas in Waveform Analysis their use is related more to the importance of frequency as a descriptive quality of its transformation property than to any analytical solution which it may offer. Because of its importance to Theoretical Physics and Pure Mathematics the Fourier Series continued to receive a lot of attention after the work of Fourier but the next most important step from the point

of view of waveform description was made by N. Wiener who re-stated and generalised the Fourier series for Harmonic Analysis, Wiener (1930), and who later extended the theory to cover the analysis of non-Harmonic Random Waveforms. This extension involved the introduction of a relationship between the Spectral functions of the Fourier Integral and the Auto and Cross Correlation functions of a waveform. The relationship has come to be known as the Wiener-Khinchine relationship since it has been jointly attributed to Wiener (1933) and the German mathematician Khinchine (1934). Apart from his purely mathematical studies, Wiener was perhaps amongst the first to consider some of the special problems associated with the description of 'Biological' waveforms, as part of his general interest in "Cybernetics or control and communication in animal and machine", Wiener (1948).

At about the same time that Wiener was working on extensions to the Fourier Series, physicists were proceeding in parallel to extend work done in another branch of Mathematical Physics by Fokker (1913) and Plank (1927) concerning the theory of Brownian Motion in Statistical Mechanics. As a result a method with which to predict the response of a complex non-linear system to random disturbance was formulated by Andronov, Pontryagin and Vitt (1933) which was later found to give an exact solution to the Fokker-Plank equation for certain non-linear systems Wang and Uhlenbeck (1945), Chuang and Kazda (1959), Aniaratram (1960), Crandall, Caughey and Lyon (1963). The Statistical Mechanics approach is distinguished from Fourier Series by its use of State Space description techniques rather than Orthogonal Functions.

In the more recent past the majority of further advances in the general theory and practice of waveform description stem from research in the field of

Communication Engineering, Rice (1944), Shannon (1948), Blackman and Tukey (1958) and Blackman (1965), Lee (1960), Bendat (1958). The 'Communication Research' was concerned with the specification of Random Noise (noise in the communication sense of the word) and its effects upon Information Transmission. As a result many of the technical difficulties associated with computation of the random descriptive functions were overcome and a formal set of practical and statistical considerations were added to the basic theory. In addition the Information Theory which sprang from the studies of Information Transmission provided an alternative means of describing and quantifying either individually or collectively, the states which occur in a random waveform in terms of a logarithmic measure of their probability (or occurrence relationship) analogous to the number of binary decisions required to locate a point on a scale of unit length. The measure expressed in BITS or BITS/sec. is related to the METRON CONTENT idea expressed by McKay in his paper on the Quantal Aspects of Scientific Information.

In addition to contributions from Communication Engineering the subject also has the benefit of advances made in the Theory of Stochastic Processes and Statistics, Bartlett (1950, 1955), Doob (1953), Bendat et al. (1962) and from individual fields of application too numerous to mention.

Stochastic Theory and Statistics of course provide far more for the subject than the mere benefit of their advances; they provide an essential foundation without which the subject could not hope to be viable. The subject of Random Waveform Description is by nature a Statistical one. Statistics provide the means by which we are able to establish the degree of confidence associated with any statement of occurrence or non occurrence that we may wish to make, but more fundamentally it is statistical in nature because it is impossible to regard a random variable as a determined function

of time. Consequently, knowledge of a single occurrence at an arbitrary instant of time has no descriptive value either for the pattern of past or possible future occurrences. This leads to the conclusion that to characterise a random waveform it is necessary to work with a finite length of waveform in order that aggregate properties such as those listed in Tables I, II and III may be calculated from the pattern of occurrence hence the need for Statistics. In Reference 2, which accompanies this dissertation the relevant parts of Statistical Description, Prediction and Decision Theory are covered in some depth with examples. The occurrence Relationships which follow represent the outcome of these historical endeavours which are likely to continue unchanged for a very long time.

For space reasons these  
Waveform Descriptions  
have been omitted but  
they are to be found in  
the report submission  
Reference 2.

NO PAGE NUMBER

130

A STUDY OF THE EFFECT OF WHOLE BODY VIBRATION ON MANUAL CONTROL

CAPABILITY USING THE ADAPTIVE TASK TECHNIQUE.

PART II

A STUDY OF THE EFFECT OF WHOLE BODY VIBRATION ON MANUAL CONTROL  
CAPABILITY USING THE ADAPTIVE TASK TECHNIQUE.

PART II      A STUDY OF THE EFFECT OF WHOLE BODY VIBRATION ON MANUAL  
CONTROL CAPABILITY USING THE ADAPTIVE TASK TECHNIQUE.

Introduction

In succeeding chapters a series of experiments are reported which feature an adaptive control task. The experiments concern the effect of whole body vibration upon a persons ability to control a simple unstable dynamic system. They were conceived as being a natural extension of previous work done by the author and they provided an opportunity to try out an adaptive task and demonstrate certain waveform techniques with the aid of a single experimental facility.

The decision to 'try out' the Adaptive Task Technique was motivated by the words of C.R.Kelley at the 3rd. International Congress on Ergonomics held in 1967 at the University of Birmingham. During discussion of his paper entitled 'Research Applications of Adaptive Tasks' Kelley pointed out a number of advantages of the adaptive technique which at the time seemed relevant to the measurement and assessment of vibration effects. Referring especially to the assessment of manual control capability Kelley stated that :

- (a) The adaptive technique was capable of separating a wider range of individual difference in skill level than non-adaptive tasks. having a fixed level of difficulty.
- (b) The adaptive technique was a more sensitive, reliable and economical method of assessing skill (or the effects of environmental factors on skilled performance) than non-adaptive alternatives.
- (c) Adaptive tasks were inherently more motivating than non-adaptive tasks.

(d) Persons with some practical experience in the design and development of automatic control systems would have no difficulty implementing an adaptive task system.

Together these advantages, if they were true, seemed sufficient reason to experiment with the adaptive technique because at the time those interested in human reaction to vibration were seeking measurement and assessment methods more sensitive and reliable than those available at the time (Whitehead 1965, 1967). Kelley's cautionary note concerning knowledge of control engineering procedures presented no problem and so began a more detailed review of the Adaptive Task Technique.

The review revealed the claim to be true for the specific situations for which there was evidence of the technique. Overall the amount of evidence available was relatively small and those interested in the technique had tended to concentrate on a breadth of application rather than depth. So in 1967 when this study began the position was more one of intellectual satisfaction with Adaptive Tasks than of empirical advantage. Today the position has changed somewhat, there is now more hard evidence available and this as far as possible has been embodied in the chapter tracing the history and status of the technique.

In 1968 the Human Engineering Division of the Royal Aircraft Establishment, Farnborough, were amongst the few in this country to have experimented with an Adaptive Task with Vibration in mind. Encouraged by their tentative results with a frequency adaptive tracking task, Coburn (1968) and by their belief in the theoretical advantages, steps were taken to implement the same system. For this purpose RAE kindly made available,



on loan, the equipment that they had used to generate the Track in their adaptive tracking task. An account of the development work involved in this phase of the study is given in the fourth of the chapters in this second part. The third chapter is devoted to a review of the effects of Vibration on Manual Control Capability and the remaining chapters to a description of the experiments performed and to an appraisal of the results.

Consideration in this study has been given to four main topics : Manual Control Skill, Whole Body Mechanical Vibration, Adaptive Tasks and Waveform Analysis. The aims of the study are defined within this ambit

For Manual Control skill the principal experimental aim was to measure the effect of random vibration on the difficulty of a manual control task - the premise being that the difficulty of a control task, involving accurate target sightings coupled with delicate control movement, must rise when hand and eye are caused to vibrate. Measurement of task difficulty increment associated with vibration increment was the idea and reason behind the use of an Adaptive task.

A second aim associated with manual control was to further investigate the effect of vibration on performance; to investigate specifically the skill, if any, that is developed to combat vibration effects and to do so for a wide range of operator experience and capability.

The specific aims associated with the adaptive task technique were to gain experience in its use, to provide an assessment of its ease of use and to establish the considerations that seem necessary in order to implement a simple adaptive task. Another aim was to discover the nature

of vibration as an adaptive variable and information feedback channel.

Vibration and manual control studies are typical of the kind that result in raw data which is waveform in nature. For this reason and because of the background interest of the author, these topics were chosen to comply with waveform analysis requirements.

The aim of waveform analysis was to integrate their consideration into the experimental design phase and to demonstrate and evaluate certain analytical techniques covered in Part I. The specific aim being to establish the relative advantages between the alternative descriptions that may be applied to the experimental data.

In transportation there are many problems of a man/machine and passenger/environment nature which are caused by vibration but it would not be realistic to justify this research on any of these practical grounds. It must be emphasised that it is a study in the abstract. It is an exploratory study of a technique which promises improvements in our methods of environmental evaluation and skill assessment. In studying the technique no attempt has been made to simulate in the laboratory the real problem situation. Neither the tasks, the vibration or the experimental environment correspond closely to that found on board vehicles.

## 2.2 A REVIEW AND A HISTORY OF THE ADAPTIVE TASK TECHNIQUE.

According to Kelley (1967) " the first machine controlled adaptive device in the continuous control field (to my knowledge) was developed in 1959 by Henry Birmingham and his colleagues at the United States Naval Research Laboratory (Birmingham 1959)". The device was developed to measure the 'bandwidth' or the frequency handling capability of the human operator performing a tracking task. The device was an analogue computer which adjusted automatically the speed of oscillation of a moving target in accordance with operator error in tracking the target. When the subject tracked poorly the system would oscillate slowly; when he tracked well the frequency of oscillation automatically went up. The operating principle of this device was subsequently used by Birmingham and his colleagues (Birmingham, Chernikoff and Zeigler (1962)) to develop a simulator for the purpose of selecting and training operators to control submarines. At the same time the U.S. Naval Training Device Centre sponsored several other studies, all concerned with the development of automatic or adaptive training devices. In addition to Birmingham and his colleagues, who appear to have been the focus of this endeavour, Hudson of the OTIS Elevator Company reported on 'An adaptive tracking simulator; Hudson (1962), Briggs of Michigan University described experiments on the scheduling of augmented feedback according to operator performance; Briggs (1962) and Kelley of Dunlap and Associates Inc. carried out the first full analysis and a laboratory investigation of the general nature of simulators that adjust their own difficulty as a function of subject performance; Kelley (1962). In keeping with its sponsorship the laboratory investigation reported by Kelley was concerned with submarines, but it was not a training study; it was an example of

Kelley's (1962) results obtained from a Self Adjusting Submarine Simulator.

Figure 2.1

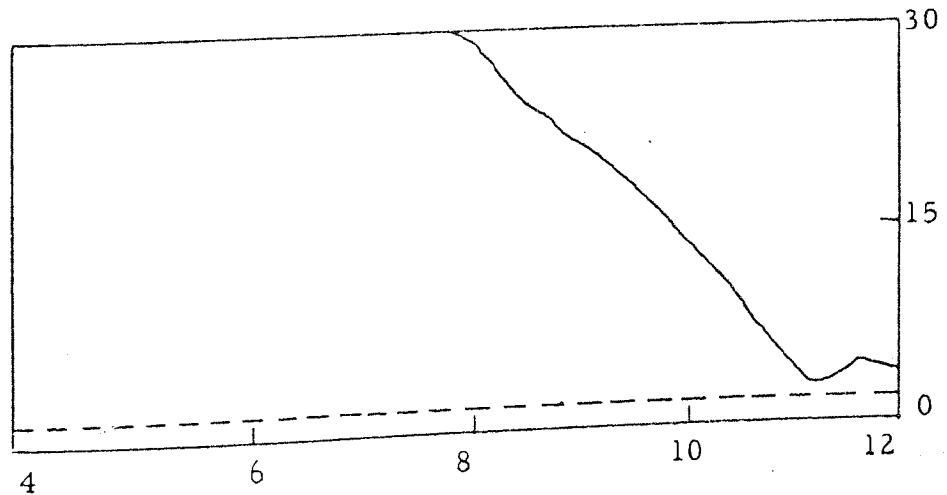
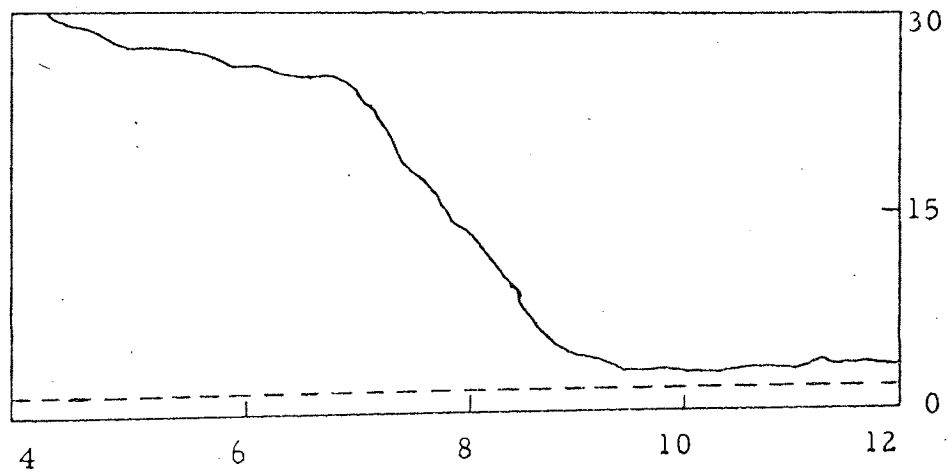
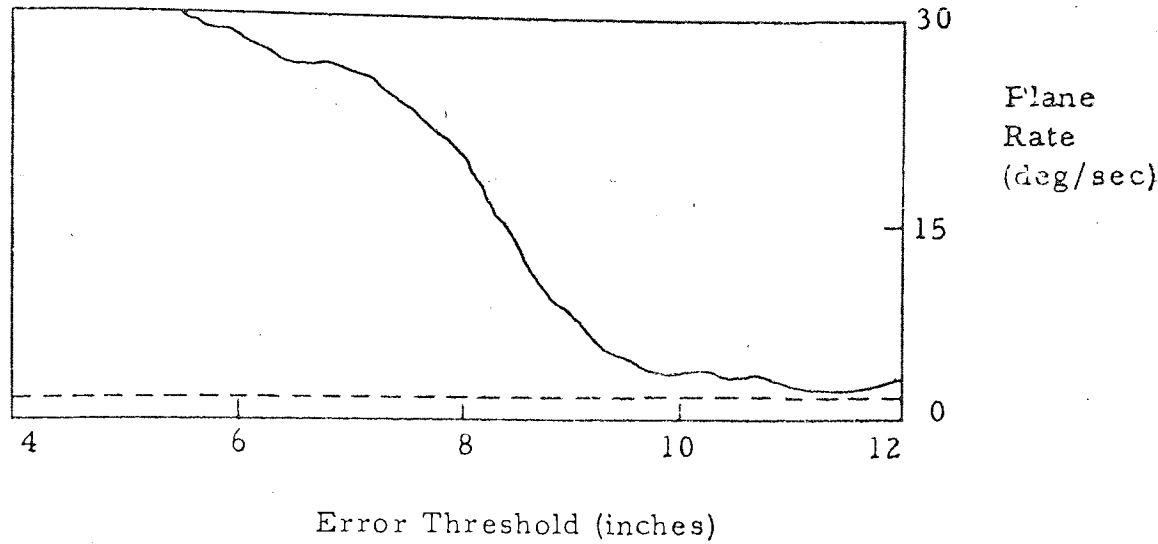

Note: that the first two records are for a Highly Skilled subject; the last was a novice.

the adaptive task technique applied to the development of man-machine compatibility. To determine the relationship between the rate of motion of a submarine's horizontal plane and the ability of the man-machine system to maintain an ordered depth in the presence of a defined disturbance, Kelley used an adaptive tracking task. In the implementation of this task the performance criterion was made to vary at a slow constant rate beginning at 4" and progressing to 12" of mean error in 30mins.. The results are shown in Fig.2.1 for 2 skilled subjects and 1 naive subject. For the skilled subjects the relationship shows a marked change in the overall sensitivity of the analysis to error above a mean value of 9" and below a mean value of 7". In his concluding remarks on this experiment Kelley comments that "the value of a curve such as this to a designer working to build a system to operate within defined tolerances is evident. The usefulness of this type of information and the relative ease with which it is obtained indicate the potentiality of the self adjusting simulator technique!"

In their contribution, Birmingham, Chernikoff and Zeigler (1962) describe "a teaching machine for the selection and training of operators of high order vehicles!" In a simulated submarine control task they adjusted the degree of augmented feedback displayed to operators according to their mean error modulus score. In this device as the operator tracked poorly he received a great deal of help from the display augmentor, then as his performance improved the assistance was gradually removed. When used as a training device the subject was supposed to practice until his performance reached a level at which there would be no display augmentation at all. When used for selection purposes subjects were tested over a fixed trial period and their

performance was judged by the amount of display augmentation that they were receiving at the end of the trial. Hudson developed a similar training device which in addition to display augmentation was able to adjust the gain of his simulated system and the amplitude of the systems disturbance using the same closed loop feedback circuit as that used for display augmentation.

In a separate paper Chernikoff (1962) described in more detail the device with which he was associated and his discussion of the adaptive task technique and its theoretical advantages over fixed non-adaptive training devices, together with that provided by Kelley and Hudson did much to establish the modern concept of the technique. Implementation, it was realised depended upon :

1. The choice of a suitable adaptive variable.
2. Measurement of human performance.
3. Development of a system of logic to relate changes in performance to increments or decrements of task difficulty (The adaptive variable).
4. The choice of a suitable performance standard or criterion with which to judge the measured performance.
5. Knowledge of results i.e. feedback to the operator on the status of his performance.

The last element was particularly important in the technique expounded by Kelley because in his adaptive method the adaptive variable was used to regulate human performance so that on the average it remained constant. Thus in Kelley's method there was no feedback inherent in the task unless the operator was able to perceive its changing level of difficulty. Since there were good theoretical and practical grounds

for thinking that he could not make this perception the provision of 'artificial' feedback i.e. a display of the adaptive variable was considered an essential element of the technique. More is said on this matter later in the section which deals with the question of motivation.

Despite their technical and intellectual content the reports on these Naval Training Devices and associated research offer little evidence of their validity and no real evidence of the effectiveness of the adaptive task technique compared with non-adaptive techniques.

Since 1962 and to date the technique has been applied to the assessment and development of a variety of skills, parameter optimisation in man-machine systems and many more applications have been suggested for it.

In more recent times, with the advent of the small on-line digital computer the use of adaptive task techniques have spread and are now used in psycho-physical (Kappauf 1969, Levitt 1970) and experimental psychological research studies (Taylor M. 1970). As a result the technique is now facing new, interesting and challenging applications and motivated by ease of programming, a new brand of conditional adaptive logic is emerging. The modern concept of the adaptive task technique is therefore being increasingly linked to the specific application area and specific use that is made of it. For example, those using it for Adaptive Training purposes are tending to think of it as 'Instructor Simulation', Caro (1971), whilst interface designers Kelley (1966) and human performance specialists, Wargo (1971) think of it as an experimental method of parameter and task optimisation respectively. Whatever the use to which it is put, the technique

**TABLE 2.1 An Historical Review of Developments in the use of the Adaptive Task Technique.**

Date & Author	Task Description	Purpose of Study	Adaptive Variable(s)	Performance Measure	Adaptive Logic	Performance Criterion	Feedback	Results
59 Birmingham	Compensatory tracking task	To study the effect of display gain on operator performance in a tracking task.	Display gain	Absolute error (averaged by filter)	$S = \int_0^T (e_t - \bar{e}_t) dt$ A. Augmentation signal	Nominal value of tracking error	None	None
60 Hudson	Compensatory tracking task	To study the effect of display gain on operator performance in a tracking task.	Display gain	Mean square error	$S = A \int_0^T (e_t - \bar{e}_t) dt$ A. Augmentation signal	Nominal error	None	None
62 Kelly	Depth control of submarine	To determine relationship between phone rate & flight control accuracy or error threshold.	Phone rate	Mean height of simulated submarine	$S = K \int_0^T (e_t - \bar{e}_t) dt + S_{in}$	Nominal value of height in range 4-12 in.	3 subjects - 2 skilled & novice	Phone rate v error threshold. Phone rate / error v dist.
64 Hudson	Two axis acceleration tracking task	To study effect of display gain on operator performance in a tracking task.	Display gain	Tracking error (vector error for multi axis tracking)	$S = K \int_0^T (e_t - \bar{e}_t) dt + S_{in}$	Nominal value of desired vector error (no specified qualitative)	2 subjects (former)	Can operate directly, effects of position, set point, gain, etc. v display gain
67 Gibson	Compensatory tracking task	To measure the efficiency of an operator in a tracking task.	Display gain	Mean error modulus	Determined by parameter D (which also determined the task difficulty)	Nominal value of tracking error	None	Difficultly v time v gain. Operator who trained on feedback device better than those who trained on high & low difficulty device. Communication effect.
67 Kelly & Wargo	Two axis acceleration tracking task	To demonstrate that a cross adaptive task performance on a primary task can carry all op. variance into task-two even both to be extended. task performance. Display gain was the input variable.	Display gain	Modulus of tracking error	$S = K \int_0^T (e_t - \bar{e}_t) dt + S_{in}$	Nominal value of desired vector error	No explicit feedback. Two subjects	Primary and secondary task scores v display gain.
67 Kelly & Proda	Single axis comp. tracking. 1. 0.1 Hz 2. 0.177 Hz 3. 0.522 Hz 4. 0.987 Hz	To study the effect of display gain on operator performance in a tracking task.	Display gain	Modulus of tracking error	$S = K \int_0^T (e_t - \bar{e}_t) dt + S_{in}$	Modulus of tracking error	One subject	Position better for high frequency and low amplitude. Rate superior to acceleration.
67 Kelly	Two axis acceleration tracking task	To study the effect of display gain on operator performance in a tracking task.	Display gain	Modulus of tracking error	$S = K \int_0^T (e_t - \bar{e}_t) dt + S_{in}$	90% threshold. I.e. subject must discriminate correctly 90% of time.	Not specified. No. of subjects not specified.	For relative gain. Mean 90% threshold was 2.0, 1.6 or 3.12% constant.
67 Kelly	Two axis acceleration tracking task	To study the effect of display gain on operator performance in a tracking task.	Display gain	Modulus of tracking error	$S = K \int_0^T (e_t - \bar{e}_t) dt + S_{in}$	90% threshold. A time interval error band.	Not specified.	Remains above effects of arithmetic and alcohol.
68 Gibson	Single axis compensatory tracking task, CRO display, control level.	To study the effect of display gain on operator performance in a tracking task.	Display gain	Mean modulus of tracking error	$S = K \int_0^T (e_t - \bar{e}_t) dt + S_{in}$	This was varied over the range 0.5 - 1.0 cm.	None	Small amount of error in display v error in performance v error in control.
68 Kelly & Proda	Two axis acceleration tracking task	To demonstrate that a cross adaptive task performance on a primary task can carry all op. variance into task-two even both to be extended. task performance. Display gain was the input variable.	Display gain	Modulus of tracking error	$S = K \int_0^T (e_t - \bar{e}_t) dt + S_{in}$	Probability of correct response	Not specified. One subject.	Target size as a function of distance. Deteriorates rate of response to reach threshold & fluency of discrimination.
68 Kelly & Proda	Two axis acceleration tracking task	To demonstrate that a cross adaptive task performance on a primary task can carry all op. variance into task-two even both to be extended. task performance. Display gain was the input variable.	Display gain	Modulus of tracking error	$S = K \int_0^T (e_t - \bar{e}_t) dt + S_{in}$	P = 0.917	One subject	Time v ellipse ratio.
68 Kelly & Proda	Two axis acceleration tracking task	To demonstrate that a cross adaptive task performance on a primary task can carry all op. variance into task-two even both to be extended. task performance. Display gain was the input variable.	Display gain	Modulus of tracking error	$S = K \int_0^T (e_t - \bar{e}_t) dt + S_{in}$	P = 0.831	Four subjects	Mean intensity difference, subject: A: 3.2 db, B: 4.7 db, C: 1.0 db, D: 4.9 db.
69 Gibson	Two axis acceleration tracking task	To study the effect of display gain on operator performance in a tracking task.	Display gain	Modulus of tracking error	$S = K \int_0^T (e_t - \bar{e}_t) dt + S_{in}$	Target size as a function of distance. Deteriorates rate of response to reach threshold & fluency of discrimination.	None	5RTs per year operational.
71 Condon et al.	Two dim. second order tracking task. Display-attitude direction. Control-on-off: side arm. Environment-realistic cockpit.	To study the effect of display gain on operator performance in a tracking task.	Display gain	Modulus of tracking error	$S = K \int_0^T (e_t - \bar{e}_t) dt + S_{in}$	Target size as a function of distance. Deteriorates rate of response to reach threshold & fluency of discrimination.	None	Two dim. display. 3) problem number. 4) level of difficulty. (in the display) problems are ordered according to difficulty.
71 Wood	Two dim. second order tracking task. Display-attitude direction. Control-on-off: side arm. Environment-realistic cockpit.	To study the effect of display gain on operator performance in a tracking task.	Display gain	Modulus of tracking error	$S = K \int_0^T (e_t - \bar{e}_t) dt + S_{in}$	Target size as a function of distance. Deteriorates rate of response to reach threshold & fluency of discrimination.	None	Method 1 - No feedback. Method 2 - Feedback tracking task.
71 Wargo	Elapsed time estimation.	To study the effect of display gain on operator performance in a tracking task.	Display gain	Modulus of tracking error	$S = K \int_0^T (e_t - \bar{e}_t) dt + S_{in}$	Target size as a function of distance. Deteriorates rate of response to reach threshold & fluency of discrimination.	None	Effect of error band on 80% threshold. Effect of error band on 50% threshold. Effect of error band on 65% threshold.



remains fundamentally an application of automatic control in which a closed feedback loop is maintained between some objective measure of human performance or behaviour and the difficulty of the task or problem to which it is referred. Thus in general terms an adaptive task is one having the facility of variable difficulty which is used to control performance or behaviour so that it meets some pre-specified standard or requirement. The general idea is that difficulty should increase when a person exceeds the performance requirement and decrease when he falls below so that at all times (or on the average) his performance is up to standard. The premise of the technique is that feedback control, when used in this way, produces a changing level of task difficulty which is related to a persons performance in a manner which is then optimal for the assessment and development of skill and working conditions.

After its initial investigations, which were reported in 1962, the U.S. Office of Naval Research (ONR) continued to support studies involving use of the adaptive task technique. This support resulted in a further report by Hudson (1964) and a series by C.R. Kelley of Dunlap and Associates Inc. which were co-authored from time to time by his colleagues Prosin and Wargo. Kelley (1966), Kelley and Wargo (1967), Kelley (1967), Kelley and Prosin (1968). Details of the experiments performed by Hudson and Kelley are given in Table 2.1, in historical order, together with the other significant developemnts that are referred to in this review. Hudson's work, which continued the early Naval Training studies, was a major experiment on adaptive training techniques. Seventy subjects trained for ten hours each on a third order, two dimensional tracking task. The results of this study together with the earlier work by Kelley (1962) persuaded Caro of the U.S. Human

Resources Research Organisation, in 1965, to specify a requirement for adaptive training techniques to be employed in the Synthetic Flight Training Systems (SFTS) planned to replace existing training simulators for U.S. Army helicopter pilots. This application reported by Caro (1969) because of its ambition and the scale of its investment provided the adaptive task technique with an impetus which at this time remains unique in the history of its development. In 1971 Caro reported on progress with the SFTS but before that time Gaines (1967), sponsored by the Ministry of Defence in this country reported on his research concerning the use of automated feedback trainers for the development of perceptual-motor skills. Gaines, like Hudson, used over 70 subjects and concluded similarly that the adaptive task technique resulted in a greater acquisition of skill than either a high or low difficulty non-adaptive task technique. Gaines demonstrated also that acquisition of skill is influenced in a positive sense by the strength of instructions given to a trainee.

Two events which mark a growing interest in the adaptive training technique and a will that it should gain greater understanding were the publication of a special issue of the journal Human Factors in 1969 on Adaptive Training and in 1971 publication of the proceedings of a symposium workshop meeting on Adaptive Training held at the University of Illinois. During this meeting all aspects of the training application of the adaptive task technique were challenged, many for the first time. There also emerged several new interested organisations such as the U.S.A.F., the consultants Life Sciences and Anacapa Sciences, the RAND corporation, Domestic airlines and several hardware and simulator manufacturers. The result was a significant rise in the intellectual level of the subject, a consolidation of latent fears and prospects

for its future and a very clear indication of the extent and limitations of existing knowledge on the subject.

Application to the assessment of human performance and to the development of man-machine compatibility is mainly the credit of Charles Kelley and his colleagues of Dunlap and Associates Inc.. In his ONR sponsored work, mentioned earlier, Kelley has developed techniques for and/or experimented with : the assessment of display gain and continuous v on-off controls in acceleration tracking tasks involving one, two and three axes; a cross adaptive task technique; a frequency adaptive tracking task; the assessment of time estimation skill; the assessment of visual acuity; shape judgement and relative sound intensity. Two practical applications having important practical consequences were Kelley's development of an adaptive tracking task to test the effect of extended weightlessness on astronaut piloting skill in connection with the Manned Orbiting Laboratory Program and second the determination of the brightness or contrast required in the head-up display of the U.S.Navy's F111B-TFX aircraft to give 90% confidence of the display symbols being intelligible against a background of sunlit clouds. The latter application resulted in a figure of 202 ft. L or 3.12% contrast for the display symbols. Commenting latter on this experiment in McGrath and Harris (1971,p.85) Kelley said "----- this experiment --- showed that the adaptive technique was an efficient way to gather data and it provided data we could have confidence in ----- I felt that the data did indeed reflect the difference among the combining glasses and we were able to supply the Navy with information that was of real value within the context of a very limited experimental budget ". It was perhaps remarks like these which caused the Royal Aircraft Establishment,

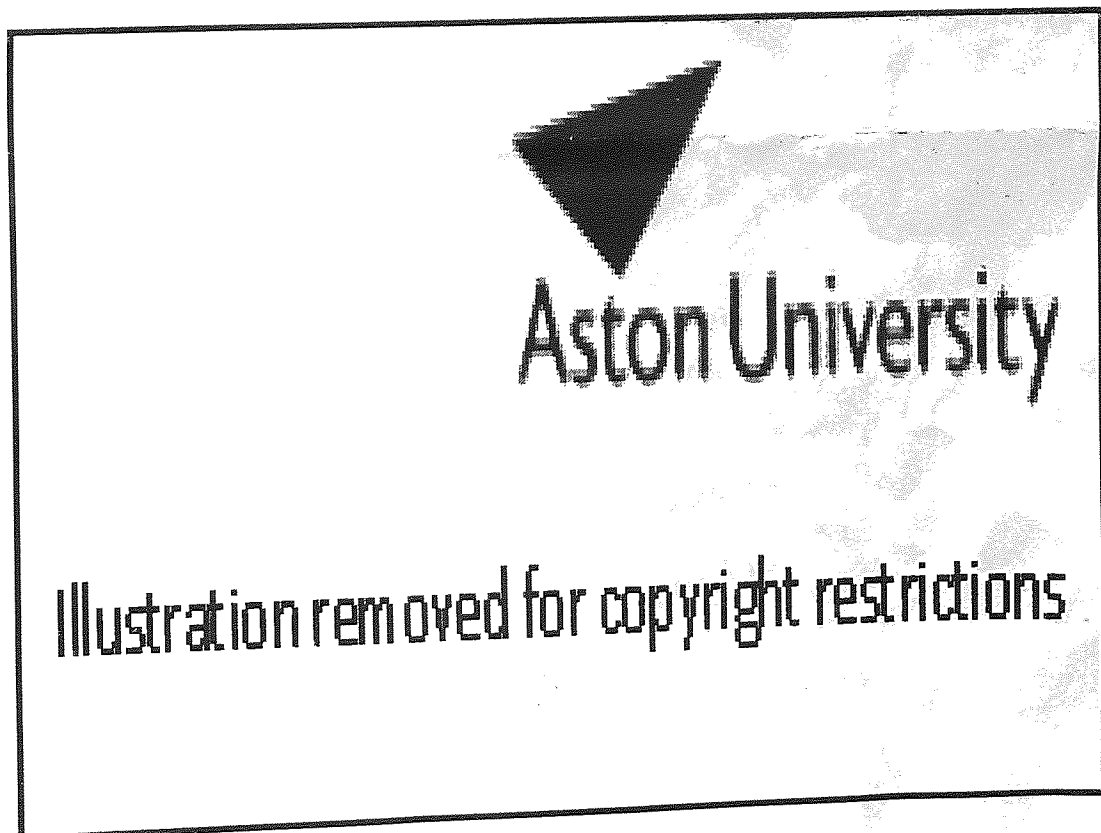

Farnborough, to look further into the adaptive technique for use in performance measurement. The Farnborough study was reported by Coburn in 1968. Basing his judgement on an analysis of the change likely to occur in tracking error as a result of changes in task difficulty, Coburn, basing his ideas on the work of Poulton (1965), postulated a set of curves relating error to difficulty for a range of individual difference in tracking capability or alternatively, levels of imposed stress. From these curves shown in Fig.2.2 Coburn then proceeded to show in concept the relationship between error and individual difference and task difficulty and individual difference for respectively, a non-adaptive task of fixed difficulty and an adaptive task performed with constant error. The result shown in Fig.2.3 and 2.4 was an ill-conditioned ogive curve for the non-adaptive task and an almost straight line for the adaptive task. In an experiment with two pilots which involved the development of a frequency adaptive tracking task, Coburn proceeded to test the relationship between error score and task difficulty. The result was a rather distorted S-shaped relationship. The significance of this result although not made explicit by Coburn is related to a statement made earlier in his report concerning the advantage of the adaptive technique. If the relationship shown in Fig. 2.2 is in general true (Coburn has tentatively shown that it is ) and if the relationship holds for a range of skill then one must obtain the relationships shown in Figs. 2.3 and 2.4. If this is so then the interpretation is that the adaptive task score discriminates equally between performance at each of the skill levels whereas the non-adaptive error score does not easily permit one to discriminate between the first three and between the last two skill levels. Coburn's relevant statement was that "Potentially the most important advantage offered by the adaptive technique is that it may effectively separate a far greater

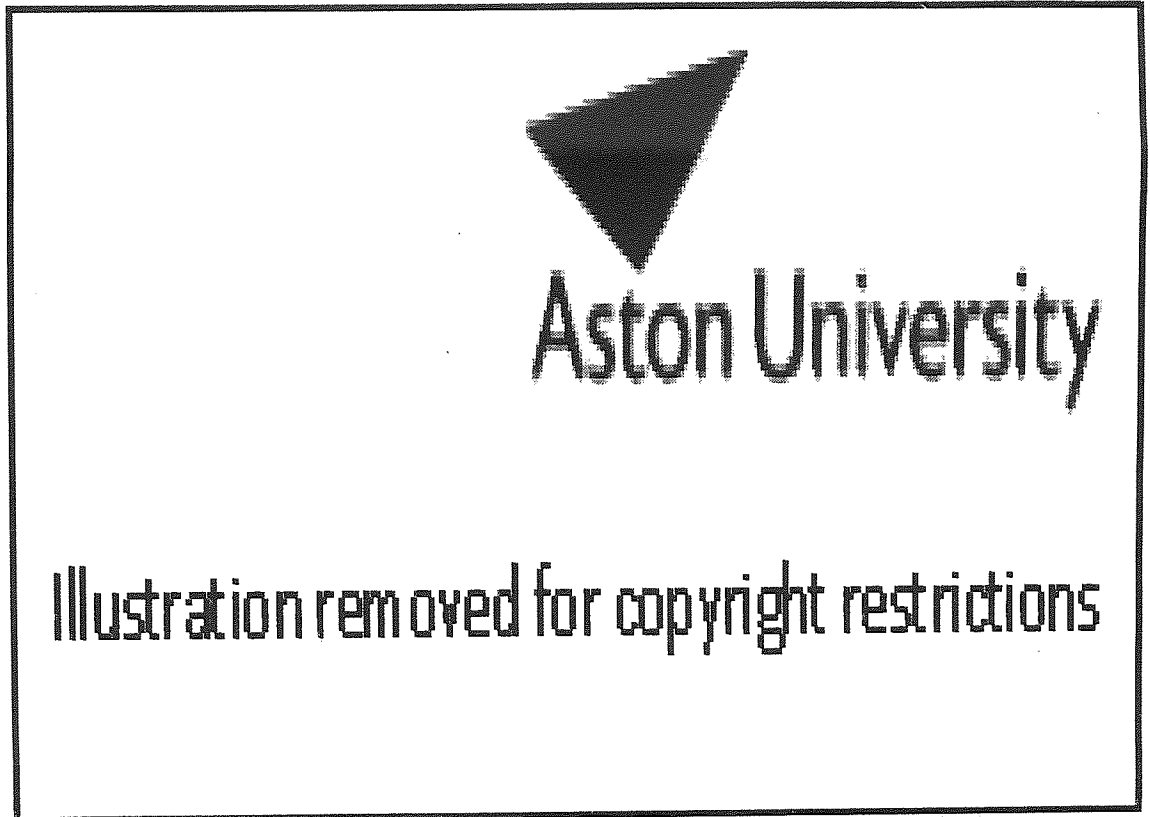

Fixed versus Adaptive Learning Curves (Kelley)

Figure 2.6

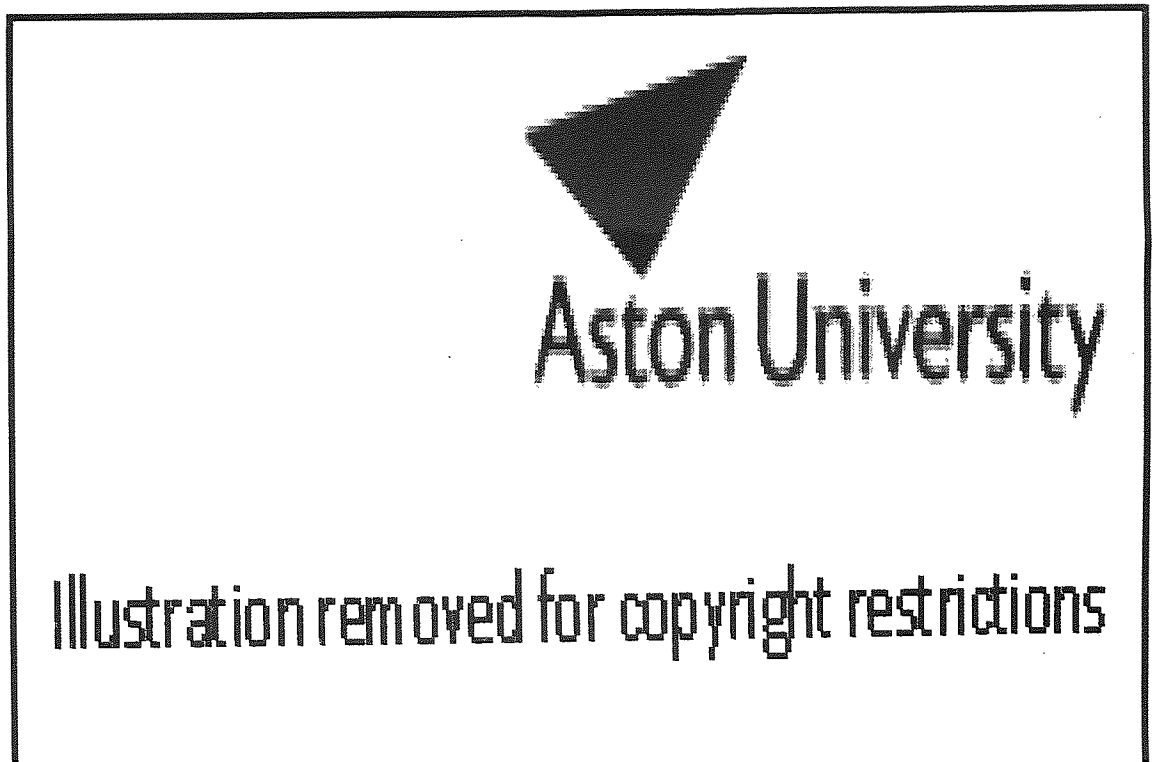

range of experimental conditions than conventional methods ----- The most carefully chosen tracking task will almost certainly prove too easy for the most skilled and too hard for those of lowest aptitude. Thus the former group will track at near zero error and will be difficult to separate. Conversely grading of the latter, less skilled group may be impossible because their attempts at control will be near ineffectual"

Evidence of a linear relationship between the degree of tracking skill and performance as scored by an adaptive variable was provided by Kelley prior to the work of Cohurn. In an experiment in which two subjects performed 20 ten minute trials a day for nine days on a two axis acceleration tracking task Kelley contrasted the adaptive task with a fixed task method of scoring the acquired skill. His method was to give subjects alternate trials on the same task first in adaptive form, then with fixed difficulty so that they performed on an adaptive trial, a fixed trial, an adaptive trial and so on for the 20 trials. In both cases subjects were given information about their performance which corresponded to the amplitude of forcing function on adaptive trials and integrated tracking error on fixed trials. The result by Kelley (1966, p.20) is shown in Fig. 2.5. This figure has two ordinate scales, one for the adaptive score and one for the fixed task score. The starting point and the end point have been made to coincide and the dotted lines show one standard deviation of the ten scores that make up each data point. Adjusting the scales in this way is valid because as Kelley points out (p.10 of M<sup>C</sup>Grath and Harris) "since subjects were trained alternatively on the fixed and adaptive trials ----- subjects were just as skilled when performing fixed tasks as when performing the adaptive task". In this respect all the points on the



graph are equal and in joining the ends by adjusting the scales one is simply showing the difference in score between two alternative ways of measuring the same thing. From the point of view of training, as will be expounded later in the section on the nature of learning with adaptive tasks, it may not matter whether the learning curve is an ogive or a straight line so long as the terminal skill can be acquired in the available time. On the other hand it does matter and it is important in measurement to choose a technique that gives the least possible measurement uncertainty (least variance). In this important respect the adaptive measurement method is shown to be much superior. From day 4 on the coefficient of variation (i.e. the ratio of the standard deviation to the mean value of the data points) for the adaptive task was in the range 0.24 to 0.07. For the fixed task method it was 0.54 to 0.31. Prior to the 4th. day of practice on the fixed task subjects error was such that it exceeded what the equipment could measure. Therefore during early trials the variance in the score is artificially small. Not until the 4th. day of practice were the subjects able to keep the pointers on scale for a proportion of the time for an accurate measure of error to be obtained. As Kelley points out (p.10 M<sup>C</sup>Grath and Harris 1971) taking the results from day 4 on "it would be necessary to take from 5 to 20 times as many trials with a fixed task as it would with the adaptive task to reach the same reliability of measurement".

This evidence on the nature of fixed task scores compared to adaptive task scores tends to confirm and to corroborate Coburn's results and analysis. Using data from a number of sources Kelley has extended the learning curves shown in Fig.2.5 to that shown in Fig.2.6. For the non-adaptive fixed task the curve is S-shaped and is shown to level off



at the end, indicating that one can go on learning much longer when problems are made more difficult than when they remain fixed.

Wargo, in the most recent paper to be published on the adaptive task technique describes what is believed to be a repeat study on the assessment of time estimation skill. As previously reported by Kelley (1967) operator performance was measured in terms of estimation error in seconds. The performance criterion was a preset tolerance error band in seconds and the adaptive variable was duration of time to be estimated. This work has resulted in a figure of mean elapsed time that the subject is capable of estimating correctly 50%, 65%, and 80% of the time when he is allowed an error margin of  $\pm 1, 1$  and  $1\frac{1}{2}$  secs.. In this paper Wargo presents a most convincing demonstration of the measurement accuracy or sensitivity of the adaptive task technique. Using analysis of variance Wargo demonstrates that 99.1% of an operators performance variability was accounted for by the adaptive equation parameters of threshold error band and their interaction and that only 0.9% of the operators performance variability was accounted for and can be attributed to error effects. In terms of conventional psychometric terminology, says Wargo, this is equivalent to saying that there is a multiple predictive correlation between threshold, error band and their interaction and time estimation skill of approximately 0.996. This is an unusually high figure considering the fact that most predictive validity coefficients reported in the literature range from 0-0.8 (Guilford 1965). "In short" concludes Wargo, "results of this study indicate that the adaptive time estimation assessment technique employed was unusually sensitive to operator skill level!" Wargo then goes on to demonstrate that adaptive assessment

systems are also more economical in test administration time and test administrator skill level, than conventional assessment systems. Using the non-adaptive method of constant stimuli to determine a subjects specific threshold would require a minimum of 140-180 trials to get enough data from which interpolation of the subjects threshold would be possible. With the adaptive system used in his study the subjects exact threshold could be determined in approximately 50 trials. Less need for test administrator skill derives from the fact that adaptive systems are automated test systems. Stimulus presentation, response recording, scoring and adaptation are automatically controlled by the system. "Consequently," states Wargo, "the test administrator need not be highly skilled and often need not be present during assessment"

Of all developments so far mentioned the most significant in terms of investment in the adaptive task technique was the U.S.Army's Synthetic Flight Training System announced in 1965 and described by Caro (1969). Concerned with the mass production of helicopter pilots the SFTS is distinguished from its predecessors by its automation of certain instructor functions. With the decision to incorporate adaptive tasks into their new system for helicopter training, those responsible for the SFTS have provided an altogether new level of application and with it new implementation problems for the adaptive task technique. It is therefore not surprising that the SFTS has become a focus of challenge and attention amongst technicians and theorists. It has raised new questions and has created a new brand of thinking about adaptive training. It has shifted the concept away from the old idea of it being a substitute or alternative to the method of fixed training to instructor simulation. After a series of concept formulation studies Flexman,

Jamesson, Walsh and Cohen (1968); Clausen, Curtin, Egler, Johnson, Nelson, Szcauka and Voss (1968); Young and Hall (1968) and Kelley and Wargo (1968) in which automation of instructor functions was examined it was decided that the adaptive concept provided a potentially useful approach to automation of one of these functions; that of problem selection. The SFTS is also unique in being both an application and a research tool combined.

In this training application four adaptive variables are used. Firstly the overall task is broken down into fractions and each fraction of skill into elements consisting of well defined phases of learning. In this adaptive variable, incremental additions or deletions can be made to the dimensions of control, to the communications or procedural loading and to the requirements for time sharing behaviour. In essence the student faces a task battery which starts simple increasing in difficulty as skill is acquired and ending in a task that provides an environment which is sufficiently realistic for the trainee to be able to perform almost all of the tasks in an aircraft during an operational flight. Details of the overall training strategy used and how the adaptive technique fitted into the scheme of things were given by Gandelman in his contribution to the forum edited by M<sup>C</sup>Grath and Harris (1971, p.51-79). Briefly, each major sub task was split into elements, for example, the ILS (instrument landing system) period was split into orientation, interception of the ILS beam, localiser tracking and glide slope tracking. Each element has a briefing, demonstration, guided practice and adaptive practice period. During briefing the computer tells the student what is expected of him and what the standards are. The computer then demonstrates the manoeuvre and the student sees the

instruments change and feels the motions of the helicopter. In the guided practice period the student performs the task but is talked through the manoeuvre. If he exceeds the error tolerance he hears an audio alarm over the headphones such as 'altitude' indicating that he is out of tolerance on altitude. In the adaptive phase his performance is scored every 10 seconds for an epoch of the manoeuvre lasting 30-40 seconds. At the end of each 10 second epoch the level of task difficulty is raised or lowered one level according to the percentage time out of tolerance on the criterion variable. The error criterion is 10% and each task element has levels 1-9 of task difficulty. The exit criterion is level 9 and the student continues to practice the same kind of task in intervals of 30-40 secs. entering each practice period at the same level of difficulty at which he left the preceding attempt. In theory the student can practice indefinitely but in practice alarm is raised by the computer and the Training manager is asked to intervene if it appears that the student is failing to make progress.

During adaptive practice feedback is given to the trainee in the form of a two digit display which is continuously updated. The first digit represents the task number and the second the level of task difficulty at which practice is taking place. In the SFTS the sub-tasks which are indicated by a task number are ranked subjectively in order of difficulty. Between tasks the difficulty is adapted by manipulating air turbulence, control damping, headwind or tailwind and crosswind, whichever is appropriate to the task and to the trainee's performance at the time. When a headwind is used it has the effect of presenting the task in slow time which gives the student time to think. A tailwind having the reverse effect. Control damping effects the moment of inertia of the

airframe and has the effect of stabilising or destabilising the helicopter.

In 1971, when progress was last reported, two complete training periods had been structured in this manner. The first period comprising basic aircraft control and instrument interpretation. The second, ILS training.

At the outset of this project it was realised that applying the adaptive concept to a complex multi-dimensional control task such as flying a helicopter involves many unknowns. Consequently in designing and in writing the computer programs a degree of flexibility was incorporated so that parameter values such as the performance measurement epoch could be modified in the light of experience during the commissioning and subsequent operational phases of the system. In this respect, as Caro (1969) has pointed out, "computer programming techniques make it possible to reverse horse and cart so that the system becomes a research tool for developing the needed parameter values whilst providing training which at the outset should be no worse than would be provided by guesses that other training techniques would require".

#### 2.2.1. Technical development.

Implementation of the adaptive task technique requires that a means be devised for altering task difficulty, that an appropriate measure of human performance be provided, that a system of logic be set up to relate changes in human performance to changes in task difficulty and that some form of feedback be given to the subject to inform him of his progress. The adaptive task technique revolves around these four elements.

Once these problems have been addressed and solutions found the next step is to build these elements into an automatic or optimal control system, so that the task can be adapted automatically, i.e. without human intervention. Development of automatic control systems always involve a compromise between speed of response or rate of adaptation of the system and its stability. The adaptive task technique is no exception. Too high a rate of adaptation will result in a hunting effect with momentary changes in performance being forever chased by alterations in task difficulty. At very high adaptive rates there is always the danger that the automatic control system will 'take over' the task duties of the subject by changing the task so rapidly that the human performance criterion is met regardless of the human operator. When this happens the resulting levels of task difficulty convey little or no information about the capability of the subject. At the other extreme too slow an adaptive rate would fail to provide the intrinsic benefit of the technique because in effect the task would no longer be adaptive. An important part of the technique is therefore the phase during which the rate parameter is chosen. In most cases adaptive rate is related to the epoch of time over which the performance of the subject is averaged. A theoretical treatment of this problem was presented by Gaines (1966) and Wargo (1971) has demonstrated the merit of choosing a high initial rate to bring the level of task difficulty quickly in line with the capability of the individual. The modern technique is therefore to choose a high initial adaptive rate to home in rapidly on the individual and then switch to a lower rate which results in more stable operation which is less likely to betray the use of feedback control.

Table 2.1 summarises the adaptive variables, adaptive logic, performance measures, performance criteria and feedback that have been used in the various applications reviewed. Amongst the applications are tasks in which the measured response is discrete in time and dichotomous or dichotomised in extent, continuous in time and extent and responses which are discrete in time and continuous in extent. The discrimination and elapsed time estimation experiments by Kelley (1969) and Wargo (1971) are examples of the first type of task. Applications involving tracking or manual control such as Coburn (1968) and Wood (1971) are examples of the second type of task and the discrimination and judgement experiments by Kelley and Prosin (1968) are an example of the third type of task. The adaptive logic equations for these three general types of adaptive task have been summarised by Kelley and Wargo (1968) and are shown in Table 2.2. The equations relate both instantaneous and average levels of the adaptive variable to a general performance variable.

### 2.2.2. Strategies of Adaptive Change.

Primarily an adaptive task system is one in which changes are made to the task along an easy-difficult dimension according to some strategy related to its application. If the application is training then the strategy will no doubt be related in some way to the goals of training which presumably are specified by the requirements of the operational task for which the skills are being developed. If the application is man-machine parameter optimisation the change strategy will relate to the performance measure of the combined man-machine system. If the application is concerned with the assessment of capability, changes will be made in such a way as to reveal either the potential or

Table 2.2

Equations for Adaptive Tasks

Equations for Instantaneous Level of Adaptive Variable

Application

$$D = K[(1-A) R - AW] + D_{\text{initial}}, \quad (1)$$

D = the adaptive variable, a higher score representing a more difficult condition

K = the sensitivity coefficient determining the size of increments and decrements in D

R = number of previous right responses

W = number of previous wrong responses

A = the desired proportion of right responses at threshold

Tasks in which measured responses are discrete in time and dichotomous or dichotomized in extent. "D" is incremented each trial by one amount or decremented by another. The relative size of an increment vs a decrement determines the level adapted to. A decrement equal to 9 times the increment will cause adaptation to a level where 1 response in 10 is decremented, i. e., the 90 per cent level.

The desired threshold in per cent is equal to 100A.

$$C = K \int_0^T (e_L - e) dt + C_{\text{initial}}, \quad (2)$$

C = the instantaneous adaptive score adjusting task difficulty, a higher score corresponding to better performance and a more difficult task

K = the sensitivity coefficient governing the rate of increase or decrease of C

e = tracking error, however that may be defined. It may refer to mean absolute error in a single axis, or to multi axis vector error, to proportion of time on target, etc.

$e_L$  = preset error threshold; when  $e = e_L$ , C does not change and the task remains fixed

Tasks in which measured response is continuous in time and in extent, as in tracking and manual control. Adaptation rate is proportional to the difference between desired and actual level of response.



Equations for Instantaneous Level of Adaptive Variable (cont'd)

Application

$$D = D_{\text{initial}} + K \sum_{i=1}^n (X_i - X_L), \quad (3)$$

Tasks in which measured responses are discrete in time and continuous in extent, the equivalent of (2) for discrete responses. Adaptive level is incremented or decremented each measured response in proportion to the difference between desired and actual level of response.

$D$  = the adaptive score at the  $n$ th measurement

$K$  = the sensitivity coefficient determining the amount of change in  $D$  per unit difference between  $X$  and  $X_L$

$X_i$  = each of the  $n$  measurements, whether they be individual scores or a running average

$X_L$  = a constant, the preset error threshold or desired value of  $X$

Equations for Average Level of Adaptive Variable

Application

$$\bar{D} = \frac{1}{n-r} \sum_{i=r+1}^n D_i, \quad (1a) \text{ and } (3a)$$

Average of the adaptive variable  $D$  for discrete responses (Equations (1) and (3)), over an averaging series of  $n-r$  responses; taken after a series of  $r$  settling responses are made to bring  $D$  to approximately the appropriate level.

$D_i$  = the  $i$ th adaptive score,  $D$ , figured as of Equation (1) or (3), and

$r$  = the number of settling trials, after which averaging of the adaptive score begins, and

$n$  = the total number of trials or scores, including the settling series,  $D_1 - D_r$

$$\bar{C} = \frac{1}{T_2 - T_1} \int_{T_1}^{T_2} C \, dt, \quad (2a)$$

Average of the adaptive variable  $C$  for continuous response (Equation (2)) over an averaging trial of  $T_2 - T_1$  seconds duration; taken after a settling period of  $T_1$  seconds is made to bring  $C$  to approximately the appropriate level.

$\bar{C}$  = the time averaged value of  $C$  in Equation 2

$T_1$  = start of averaging period (end-of-settling time), and

$T_2$  = total length of the trial including the settling period of length  $T_1$

existing capability of some subject. Those concerned with training applications sometimes argue that the change dimension easy-difficult should more properly be referred to as unrealistic-realistic to conform to the idea that the training objective should be to change the skill from some point where it is unrealistic to the point where it is realistic in operational terms.

The equations in Table 2.2 are specific examples of strategies that may be used for adaptive change. The simplest strategy of all, in cases where it can be applied, is to change the performance standard, the strategy being to raise the standard as skill and thus performance rises and to lower it in the event of a fall off. However as Kelley has been at pains to point out (in M<sup>c</sup>Grath and Harris, 1971, p.7) two things are then changing at the same time. They are the performance standard and the adaptive variable. Thus although it is a simple technique its simplicity is offset by the difficulty one finds in having to interpret the results. Other strategies have been developed for specific usage and some of these have been described by Kelley in the same publication. One strategy worth mentioning uses a deadband so that whenever the subject is performing within specified limits the adaptive task remains fixed. Only when performance exceeds the limits of the deadband is the task made easier or more difficult. This strategy has the advantage that it prevents the system continually changing and it adds to its stability by stepping from an adaptive task to a fixed task at intervals determined by the time it takes the subject to exceed the performance deadbands. Other simple strategies which change task difficulty include the adjustment of error tolerance and the addition and subtraction of secondary tasks. Secondary adaptive

tasks have been studied by Kelley and Wargo (1968) as a possible alternative to adaptation of the primary task. These authors have shown that the Cross Adaptive technique is very effective as a means of controlling performance on a primary task, and that all changes in performance are reflected as variation in secondary task difficulty.

The argument against the use of secondary tasks is that they add a new dimension to the primary task. Some argue that the use of a secondary task for training purposes is tantamount to teaching time sharing behaviour; which may not be the behaviour that is required in the operational situation.

A far cry from the simple analogue circuits which were used in the early applications involving compensatory tracking tasks was the demonstration in 1969 by Connelly and Schuler of the use of optimal control theory. For their demonstration Connelly and Schuler chose the task of a pilot attempting to land an aircraft along a preferred trajectory or glide slope. In this development the performance of the human operator is measured by comparing his performance and control policy to that of an optimal controller. When used for training purposes the strategy of the optimal control technique is to take over control when the performance of the subject becomes non optimal. When this happens the optimal controller cuts in, calculates the best control policy required to retrieve the situation, implements the policy thereby demonstrating what best to do in the error situation. The optimal control strategy thus closely resembles that of a skilled human instructor who varies task difficulty by lending a hand at times of need in the hope that eventually the trainee will go solo.

Amongst the many considerations concerning strategies of change it has now become clear that they should include the rate of adaptation, task sequencing, the initial adjustment problem, the phases of learning, the treatment of recognition milestones and the relevance of related fields of study such as Computer Aided Instruction. Both empirical evidence and theory now suggest that changes should be made slowly rather than rapidly. This was confirmed by Wood whose findings are summarised in Table 2.1.

### 2.2.3 Performance Measurement,

Whatever its application the adaptive technique is crucially dependent upon the veracity of the human performance measure. Development of the adaptive task technique therefore can go no faster than the rate at which human performance measures are being developed. For this reason a number of protagonists of the technique, such as Knoop (1966, 1968) have focussed their attention and efforts on this important aspect.

### 2.2.4. The nature of learning with adaptive tasks.

In the adaptive training as in any other training situation the aim of the student is to learn. To learn he must practice the task making errors on the way, correcting those errors as he goes along until eventually he reaches a level of competence which marks the fulfilment of the learning aim. When this happens the training situation has achieved its objective and is then ready to start all over again with a fresh trainee. Questions like does the trainee reach this terminal state faster, does the trainee retain what he has learnt better, does

adaptive training cost less, is it better for overlearning rather than threshold learning requirements - are questions for which tentative answers are presently available. The work of Kelley, Hudson and Gaines has proven the adaptive technique to a limited degree but many questions remain unanswered. In nature it differs fundamentally from non-adaptive training methods. It is<sup>a</sup> totally different learning situation which offers a student less breadth of experience than a fixed task. For example in a task of fixed difficulty where control is exercised the trainee can make large errors and get himself into a hopeless situation. In an adaptive task large error and hopeless situations are usually avoided by the control that is exercised over the performance of the trainee. Students trained with the adaptive technique are therefore deprived the experience of large error and prevented from making a mess of things. In a task of fixed difficulty there is feedback inherent in the task itself. In an adaptive task this is not so because the average performance of the trainee remains constant. Adaptive tasks are not completely devoid of inherent feedback however because it is only on the average that performance is constant. From moment to moment sizeable variations from the standard occur. The extent to which this can happen is dependent upon the response rate of the adaptive variable. The higher the rate theless there is inherent feedback, the slower the rate the more. To combat this deficiency in the adaptive training system it is usually recommended that knowledge of results be given by displaying in some way the state of the adaptive variable that is equivalent to the level of task difficulty that the subject has managed to attain as a result of his endeavours. The fear is that artificial feedback in this form might constrain the subject to learning along the dimension of the adaptive variable. In most cases the protagonists of the

technique appear to accept this viewpoint but usually point out that it does not matter so long as the trainee manages to reach the terminal task and reach it quicker and with a greater retention. This is an issue which appears to be unresolved at present.

#### 2.2.5 Motivation.

Another issue at present unresolved concerns the motivational characteristics of an adaptive task. There seems no logical reason why a person should want to continue to try and master a task or problem that is forever beyond his gift. On the other hand those who have used adaptive tasks claim that motivation is not only maintained but is better than that exhibited in non-adaptive fixed difficulty tasks. What is more a trainee expects good performance to improve the situation. An adaptive task does the opposite. The reward for good performance being a worse situation. This obviously represents a continuous challenge which appears to be the only logical reason why anyone would want to maintain an interest in something that he must realise he could never conquer, Kelley argues that so long as the subject can be made aware of the state of the adaptive variable and can therefore see his progress in terms of task difficulty no motivation problem should arise.

It has been pointed out many times that a student who knows that he is in an adaptive learning situation might choose to behave in a manner which causes him to exert least effort. To do this he merely has to perform poorly to obtain an easy task. By this means the learning situation can be changed from a stimulus/response to a response/stimulus situation in which the subject tends to respond in ways which provide

the stimulus that he is after, Daunting though this prospect might appear those who have used adaptive training techniques have found that in fact the reverse effect takes place, namely that students are much more motivated and tend to exert a greater effort and to sustain their effort longer when practicing an adaptive task. The complete answer to the response-stimulus problem seems to be an adaptive training system where the adaptive changes take place at a rate at which they are imperceptible. The student then has no reason to suspect that he is in an adaptive learning situation and therefore has no reason to expect a reward for poor performance. In most non-adaptive learning situations the student will eventually achieve mastery and will experience closure on the task. Also students traditionally expect to do better with practice. In the adaptive situation he does not have this experience his performance does not get better because his improvement is continuously or discretely being translated into increments of task difficulty. To avoid confounding this expectation is another reason why the state of the adaptive variable should be displayed to the subject (it is in the case of the SFTS).

#### 2.2.6 Relative Advantages.

The original argument in favour of using an adaptive task was that it effectively eliminated mismatch between the skill level of an individual and the difficulty of the task. By avoiding tasks that are too easy and too difficult trainees are prevented from developing bad habits and skills are developed efficiently. They are always practicing on a task which is within their capability to perform and learning time is not wasted by their attempting to perform a task that is hopelessly out of

his reach. Learning time is saved also by giving trainees who have already acquired a proportion of skill, a task that is representative of their past experience and worthy of their existing skill level.

This argument was, and still is, the main impetus behind the use of the technique for training purposes. It was the principle reason given by the U.S. Army for including adaptive training concepts in their SFTS. There are, however, many other advantages of the technique, some are side effects, some main effects.

Implementation of the technique causes attention to be focused on to the measurement of performance, task difficulty and adaptive logic. The technique thus imposes a discipline which results in a more formal structuring of the learning situation, an effect which must be regarded as a positive step forward.

The human instructor is, of course, the archetype of adaptive training. Adaptive training is therefore no more at present than Instructor Automation or Simulation. It is likely therefore that it will be useful whenever there is a need to avoid using an instructor or whenever instructor variance is thought to be a serious deficiency of a training scheme. In this respect the development and use of a rigid adaptive logic whilst central to the adaptive technique appears incidental to the instructor method. So far the technique has not been used sufficiently for anyone to be able to judge whether the strategic flexibility of the instructor, which seems vital to the treatment of individual difference, represents an overwhelming or somewhat lower degree of advantage over the virtues of a consistent logic which on the face of



it offers trainees no more than an equal opportunity. Indeed as Kelley has admitted (M<sup>C</sup>Grath and Harris, 1971, p.110) the advantages of the adaptive training technique at the moment are more theoretical than empirical. For example it offers the benefit of providing a detailed record of skill development - knowledge which could well be of use in formulating new learning theories. In summary the main advantages of adaptive training appear to be :

1. Better control over the learning situation.
2. Use of a rational decision function to relate changes in the task to changes in performance.
3. A reduction in the variance normally associated with the guidance and adaptive functions performed by an instructor.
4. The provision of equal training opportunity.
5. The focusing of attention on to the measurement of performance.
6. Standardisation and reliability, i.e. a reduction in the variance between instructors.
7. Provides a means of unburdening the instructor thereby liberating him from those burdensome duties which restrict his capacity to perform the more intelligent functions required of training management.
8. There is some evidence that in some respects the adaptive training technique is more effective than non-adaptive training. Norman (1971) in M<sup>C</sup>Grath and Harris, p.30, has shown that for psychomotor skills both transfer and retention are better, particularly in tasks for which there is an overlearning requirement.

2.3. A review of the effect of whole body vibration on manual control capability.

2.3.1. Introduction

Whole body vibration is a pattern of movement which implies the application of a varying pattern of force sufficient to move the whole or a major part of the body mass. For manual control capability the meaning and consequence of such force depends upon its magnitude, direction, duration, frequency, where it is applied and many other factors.

Such force patterns as exist at the interface between man and machine may be conceived as possessing a number of properties. Relative to the human body and most fundamentally, such forces are a source of energy, a prime mover and a stimulus. They are an environmental stress and a source of information about the interaction between man, machine and environment. They inform on the dynamic and mechanical state of the machine and indirectly convey information about the excitation characteristics of the environment external to the machine. In the communication sense, if they are noise, they are likely to mask motion cues which are an important item of information in manual vehicle control.

These properties are the nature of vibration as a cause. Their effect on human control capability is at times both a help and a hindrance. It is helpful in the sense that it is arousing and informative and a hindrance because it interferes with visual performance, manual dexterity and because it places an intensity restriction on the dynamic environment

that can be occupied by man as a controller. A restriction which may to some extent be overcome by the use of a teleoperator control but not if the presence of man on board is a primary requirement. To some system designers this is a matter of some importance. To others to endure it and perform well, in spite of it, is the challenge and the thrill associated with many sporting activities. In view of these properties it is conceivable that changes in manual control capability may result from changes in the information quality of the force pattern as well as from the environmental stress and mechanical effects which result from their prime mover qualities. Such changes occur both as a direct and indirect result of vibration, indirect consequences being often at the end of a complex causal chain.

To man as a controller vibration is a natural concomitant of most vehicles. It is either ignored or dealt with in the normal exercise of control skill. Only in vehicles which operate off highway or which encounter rough weather does it ever reach problem proportions. In some special vehicles, mainly military ones, such as low altitude high speed aircraft, severe vibration is a feature of the normal operating condition. For such vehicles vibration was thought to represent a real problem from the point of view of manning and control capability. As a result, considerable research effort was expended by those nations developing such weapons to evaluate its human welfare and performance consequences. The result is that more is now known of its effects on control skill.

At Low Altitude High Speed Flight levels vibration was found to effect

only certain components of the overall LAHSF task. Vigilance aspects of the task were effected but not performance of the primary terrain following component. This would suggest that time sharing skill was impaired but not psychomotor skill as a result of attention being focused, perhaps dedicated, to the primary collision avoidance task. This in turn suggests that the consequences were dictated by the perceived priorities of the situation with the result possibly that more effort was devoted to important aspects of the task and less to those perceived as being of lower importance rather than any fundamental contraction in channel capacity or depreciation of signal detection performance. Thus on the grounds of LAHSF research alone there would appear to be conjecture as to whether the effect of vibration is merely to make the task more difficult or whether it causes some fundamental change in capability. The signs are that it is the former rather than the latter and that in most cases the limit to control is set by willingness to tolerate rather than impairment of skill. To clarify the position, evidence of vibration effects on performance has been examined and conclusions are drawn concerning factors which appear to influence the effects and the reasons why performance changes occur.

### 2.3.2. Control Skill

Exercising control skill in an operational situation may be conceived as consisting of the exercise of three types of skill. The first type is psychomotor skill involving the coordinated performance of a highly complex multidimensional task. The second is procedural skill which involves communication, compliance with formal and social procedures and the like which demand execution of fairly complex patterns of

behaviour. The third skill is time sharing between the execution of psychomotor and procedural skill.

### 2.3.3. Psychomotor Skill

Included in psychomotor skill is the ability to exercise speed, position and attitude control over the vehicle according to the demands and risks of the developing situation. It involves development and periodic refreshment of a conceptual model of the vehicle dynamics, the development and execution of action, search and scanning routines, pattern perception, risk perception and problem solving. The latter skills are intellectual rather than psychomotor and should be categorised as such but it is always difficult in control skills analysis to decide where psychomotor skills end and intellectual or cognitive skills begin. In car driving 'automatic' or sub-conscious control is a common experience amongst people who have habituated to a particular journey. So long as nothing unusual happens well developed sensory-perceptual and response routines will control the vehicle whilst a person's spare mental capacity is occupied or pre-occupied with an independent consideration of matters unrelated to the driving task. When this happens control is being accomplished through the exercise of psychomotor skill alone. There is no requirement for problem solving or intellectual skill to be brought to bear. Only when it is perceived (seemingly at the precognitive level) that the general action routines cannot cope with the specific situation, does the task call for problem solving skills. This rather simple example does emphasise and exemplify psychomotor skills and at the same time it helps to identify when and why the higher level skills are called for. In adapting the state of

the vehicle to the prevailing internal and external environment the human operator is probably using mostly psychomotor skill with perhaps a little problem solving going on in the background. Rapid changes in vehicle characteristics, on the other hand often call for the rapid development of new control policies and sometimes man as a controller may be forced to revise his concept of success in the operational situation or to modify objectives, in which case predominantly intellectual skills will be called for; in some cases to the total exclusion of psychomotor skills.

#### 2.3.4. Procedural Skill.

Involves actions and reactions which are required in order to comply with, for example, air traffic and road traffic rulings. The skill involves being in the right place at the right time, communicating similarly in the appropriate language and co-existing according to prescribed rules and regulations.

#### 2.3.5. Timesharing Skill.

Involves judging when and when not to switch between psychomotor and procedural executions. When it is required it means keeping track of the relative consequences of neglecting one or the other and taking appropriate action before the consequences develop into either an infringement of regulations or a potentially dangerous situation. During flight under instrument flight rulings (IFR) a similar skill is involved which requires the development of a strategy for sampling instrument readings to which must be added procedural requirements of air traffic control

### 2.3.6. Assessment of Control Skill.

Assessment of the effect of vibration on control skill may be carried out in terms of its effects upon :

1. The component processes of performance such as sensation, perception, decision, memory, response.
2. The performance of less isolated control tasks contrived for the purpose of experimentation eg. tracking tasks, vigilance tasks.
3. The performance of isolated tasks that are a component part of some operational task eg. dial reading, speech communication, minor control setting, control of fuel consumption.
4. The full operational requirements of man as a controller.

Most scientific assessments to date fall into the first and second categories. As a result there is in existence a pool of information on such fundamental skills as the ability to maintain constant foot and hand pressures on a control, reactions and choice reaction time, short term memory, compensatory tracking as a function of controlled element dynamics, whole body orientation. Such assessments of this type provide fundamental insight into the nature of vibration effects. They aid understanding and explanation of effects observed or likely to occur in practice but do not themselves predict what will happen when vibration is encountered in the operational control situation, unless of course as a predictor such assessments have been validated against operational criteria. The incidence of vibration effects that have been judged against operational criteria is far less, as one might expect, but of course our experience of it is ordinate. Experience of agricultural tractor driving is that performance of the control task is often compromised

for the sake of ride comfort. We know that people slow down when going gets rough in order to protect themselves, their vehicles and its cargo. They adapt to the vibration and as a result their performance of the control task does not suffer because task difficulty is kept within manageable proportions at the expense of speed or position. The operational requirements of a task may or may not permit such behaviour. In the tractor case they do but there are examples of tasks, particularly sporting and military ones which do not. For such tasks assessments of the third and fourth type are important but are seldom carried out.

Realistic assessment should consider all three types of skill associated with manual control and the method of assessment should be appropriate for each type. Capability may be measured according to speed and accuracy or alternatively in terms of the difficulty of task that a person can sustain whilst having to maintain some predescribed standard of performance. In no instances have there been reports of the latter adaptive assessment scheme having been used. In all cases the method has been to measure performance.

### 2.3.7. The breadth of Evidence.

The effect of vibration on Human Control Ability has been studied in connection with Helicopters (Billings C.E. et al.(1968), Brown W.K. et al.); Space Flight (Young J.W and Barker L.E. (1963)), Kaehler R.L. (1959) ; Low Altitude High Speed Flight (Hornick and Lefritz (1966), Hurt G.J. (1963), Fraser T.M. (1964), Soliday and Schohan (1963, 1965), Schohan, Rawson and Soliday (1965); General Flying Ability



(Bartlett, Sir Fredrick (1951), Clark C.C. (1962), Ema T. and Tsukahava T. (1968), Drinkwater B. (1967), Lewis R.E.F. (1961), M<sup>c</sup>Kenzie J.M. and Fiorica V. (1965), Sadoff M. and Dolkas C.B. (1967); Railways (Buck (1968); Pilot Training (Buckhaut R. et al. (1963).

N.A.S.A. Research on control problems encountered in severe turbulence has been summarised by Sadoff M. et al. (1966) and Caiger B. (1966) has provided an account of some problems in control arising from operational experiences with jet transports.

Almost without exception the investigations have been carried out in the laboratory using a variety of shakers and motion simulators facilities. A large number of studies have been conducted similarly to examine the effect of vibration on a variety of contrived tasks and component processes of performance. Experiments using contrived tasks include, for example, tracking, dial reading, minor control operation, and monitoring. Of the component processes the visual sensory and manual and speech response processes have received most attention for the obvious reason that they play a major part in manual control skill and are directly effected by vibration. What is more, the effect of vibration on vision and manual dexterity can be used to explain most of the negative effects that have been observed in the studies conducted so far. Perceptual, memory and decision processes have in general received less attention but their study has recently attracted more research, eg. Harris and Sommer (1971).

Extensive psychophysical measurements have been made of motion sensations in order to assess their acceptability. To man as a controller

such sensations are important because the attitude that they engender largely determine the intensity of vibration that a person will tolerate voluntarily. It is also likely that attitude towards vibration influences both behaviour towards and performance of the control task. For these reasons what we know about vibration psychophysics can be useful when seeking to explain changes in performance that appear to be related in some way to willingness or motivational factors.

In succeeding chapters emphasis has been placed upon an examination of research involving realistic rather than abstract control tasks, but abstract studies have been consulted when seeking to explain the 'realistic' findings. In order that meaningful comparisons be made between studies, results, which have been expressed in a diversity of performance measures, have been converted where possible to percentage units of increment or decrement relative to performance under conditions of no vibration. Further, the review, because of its emphasis on realism, has tended to favour consideration of those studies involving random vibration rather than sinusoidal or other more contrived forms of vibration input. For this reason Rms 'g' was chosen to describe vibration intensity rather than peak 'g' or vibration amplitude. This choice overcomes the problem experienced when trying to convert the measure of random vibration into the sinusoidal units of peak acceleration velocity or displacement amplitude.

#### 2.3.8. Simulation Studies.

Comparable experiments involving simulated aircraft control tasks have been reported by Soliday and Schohan (1964, 1965), Schohan, Rawson and

TABLE 2.3 SIMULATION STUDIES : EXPERIMENTAL DETAILS

Author	Vibration	Duration	Seat	Restraint	Subjects	Primary Task	Secondary Tasks
Soliday S.M Schohan B. (1964)	0.29 RMS 'g' Simulated LAHSF vibration, closed loop with pilot inputs	1.5Hr	Military Aircraft A.5.A. seat	Full Torso Harness	3 Experienced Pilots	2 Dimensional Comp. Tracking in form of Simulated Terrain Following/Avoidance	1. Heading Control (in response to requests from navigator. 2. Emergencies - response to faults.
Soliday S.M Schohan B. (1965)	0.40 RMS 'g' Simulated LAHSF vibration, closed loop with pilot inputs	1.0Hr	Military Aircraft A.5.A. seat	Full Torso Harness	3 Experienced Pilots	2 Dimensional Comp. Tracking in form of Simulated Terrain Following/Avoidance	1. Heading Control Compliance with Navigation Request. 2. Response to Emergency Warning light. Fault detection.
Schohan B. Rawson H.E Soliday S.M (1965)	0.05 - 0.40 RMS 'g' Simulated LAHSF vibration, closed loop with pilot inputs.	3.0Hr	Military Aircraft A.5.A. seat	Full Torso Harness	6 Experienced Pilots	2 Dimensional Comp. Tracking in form of Simulated Terrain Following/Avoidance Task.	1. Visual search - Target Recognition. 2. Response to Electronic target Sensor. 3. Response to Electronic Counter- measures Warning light.
Holland C.L (1966)	0.12 & 0.16 RMS 'g' Triangular PSD 0-6Hz, Peaks at 2Hz, 5Hz. Vibration Independent of Task.	6Hr	Rigid Students desk/chair	Seat belt and shoulder harness	12 volun- teers. Cadets with some flight experience	2 Dimensional Comp. Tracking. Track in each axis. Statistically equiv. but independent. Track sum of 15 sine waves in equal steps between 0.075 & 0.75 rads/sec.	1. Auditory Detection - change in tone from 1200 to 1600 Hz. 2. Monitoring and cancellation of red and green warning lights.
Hornick R.J Lefritz N.M (1967)	0.1, 0.15 & 0.20 RMS 'g' PSD (see Fig. 1) Spectrum 0-12Hz, peak power 0.01g <sup>2</sup> /c/s centred on 1Hz. Vibration Independent of Task.	4Hr	Hardwood seat	Lap Belt Restraint	10 Pilots experienced in simulat- or flying.	2 Dimensional Comp. Tracking. Terrain following at a simulated altitude of 250 ft.	1. Response to Electronic Countermeasures warning light. 2. Response to change in thrust command indicator.

Soliday (1965), Holland (1967) and Hornick and Lefritz (1966). In each a two dimensional terrain following compensatory tracking task was supplemented by one or more secondary tasks; Holland used two secondary tasks. The first, a visual reaction time task, introduced a requirement for time sharing behaviour; it involved three red and three green warning lights. The lights were placed in the central vision area some 5" to the left and 5" below the centre of the 5" CRT tube which was the display for the tracking task. In the normal condition the green lights were on and the red lights were off. Intermittently, individual lights came on and went off. Subjects were expected to restore the lights to their original green-on - red-off condition by pressing an appropriate button. The second task required subjects to respond to a change in the frequency of an auditory tone played through headphones. The normal tone of 1200Hz. was presented to the subject for 0.25 secs. at a rate of 1 signal per second. Intermittently the tone would change to 1600Hz. and subjects were given 1.75secs. to respond to the change. In the account of his experiment Holland is not explicit about the change. He does not say whether subjects were given 1.75secs. to respond to a single 0.25sec. 1600Hz. signal or whether the 1600Hz.0.25sec. signal was sustained for 1.75sec.. From the vigilance point of view the former is the more difficult task. Hornick and Lefritz positioned a single red warning light/switch below the CRT tracking task display. When it illuminated subjects depressed the light/switch as rapidly as possible with their left hand as if to activate an electronic counter-measure (ECM) device. To assess vigilance for subsystem monitoring they added a third thrust management task. Two engine thrust indicators were used; one to display a thrust command signal and the other actual thrust. The command indicator was programmed to deviate and subjects used a left

hand throttle lever to align the indicators. This task, like the visual secondary task used by Holland established a requirement for visual time sharing behaviour. Being a secondary tracking task it probably called for division of attention between left and right hand movement as well as division between information sources. This suggests that it was a more 'attention demanding' secondary task than that used by Holland.

Soliday and Schohan (1964,1965) added an emergency and heading control task to terrain following/avoidance. A master light gave warning that a fault condition had occurred to which the subject responded by cancelling Attention was then transferred to a bank of warning lights where the fault condition was read off. Altitude error, heading accuracy, reaction time to the master warning light and emergency task performance time were the performance scores. Schohan, Rawson and Soliday (1965) in what appears to have been a more realistic simulation of LAHS flight subjected aerial observers to the same vibration that pilots had previously experienced. To their primary task they added target recognition, response to an electronic target sensor and response to an electronic countermeasures warning light. In the target recognition task the subject was required to name all features of military significance shown on a TV display of the terrain. The aerial observation task involved computation of wind direction and velocity, ground speed, fuel consumption, estimated times of arrival, recognising visual checkpoints and making new heading requests.

In the experiments by Hornick et al. and Holland neither type of terrain being followed nor pilot control actions had any influence on



Aston University

Content has been removed for copyright reasons

Schohan  
Rawson  
Soliday (1965)

Holland (1966)



Aston University

Content has been removed for copyright reasons

Hornick & Lefritz(1967)



Aston University

Content has been removed due to copyright restrictions



the intensity of vibration (which was stationary over the task period) but it did in the studies with which Soliday and Schohan were involved. In their studies vibratiob intensity was closed looped with pilot inputs. That is to say intensity was related to aircraft altitude and airspeed. In the Schohan, Rawson, and Soliday (1965) study this resulted in a highly non-stationary vibration environment whose intensity over a 3hr. period varied between 0.05 and 0.40 Rms'g'. When compared to the actions of an autopilot Schohan et al. calculated that pilot control actions added 17% to the 'g' levels to which they were themselves subjected. In all five studies, subjects, in common, were exposed to single axis vertical random vibration. Displays were all mounted on the moving base of the simulators and all subjects wore a harness restraint. Vibration and seat details are given in Table 2.3. Note that the intensity levels and spectral characteristics of vibration used were, with the exception of Holland, chosen to simulate that found in LAHS flight. Holland contrived his vibration so that he could test the effect of a difference in the position of the spectral peak.

Table 2.3a summarises the vibration conditions and results of the simulated control tasks. Vibration effects on primary task performance are shown in Fig.2.7. Secondary task performance and effects on physiological variables are shown in Fig.2.8

#### Performance Effects.

Collectively, with the exception of Holland, the results show that random vibration up to a level of 0.4Rms'g' has little or no effect upon primary terrain following/avoidance performance. Whilst its effects upon

TABLE 2.3 (b) SIMULATION STUDIES - SUMMARY OF VIBRATION EFFECTS

AUTHOR	VIBRATION	PRIMARY TASK	SECONDARY TASK
Soliday S. M. & Schohan B (1964)	0.29 Rms 'g' peak intensity; 1.5hr exposure	No effect	No effect
Soliday S. M. & Schohan B (1965)	0.40 Rm 'g' average intensity; 1hr exposure	No effect	No effect
Schohan B, Rawson H.E. & Soliday S.M. (1965)	0.05-0.40 Rms 'g'; 3hr exposure	Generally no effect but tendency to crash at highest vibration and task difficulty level.	Effect only on ECM warning light reaction time at highest gust levels. Reaction time increase from 0.9 - 4.0 secs
Holland C.J. (1967)	0.12, 0.16 Rms 'g' PSD 1 - 6 Hz peaks at 2Hz and 5Hz; 6 hr exposure.	No effect on performance of aerial observation tasks.	4% Increment in visual monitoring performance with 2Hz spectrum at 0.12 Rms 'g'; Decrement of 4% with 5Hz spectrum. No other effects.
Hornick R.J. and Lefritz N.M. (1966)	0.1, 0.15, 0.20 Rms 'g'; PSD - 0.01 g <sup>2</sup> /Hz peak at 1Hz; 4 hr duration.	No effect	21% decrement (2.5 - 7.9 sec) in reaction time associated with thrust regulation task; decrement not related to intensity.



certain secondary tasks was more marked. Holland, and to some extent Schohan et al. found a decrement in primary task performance. Differences which might explain Hollands result include : subjects, task difficulty, type of control and nature of vibration. Subjects in Hollands experiment were naive. In the other experiments experienced pilots were used. His control was of the rate type and the description of his tracking task suggests that it was more difficult than in the other studies. The most likely explanation is that lack of skill and task difficulty combined to produce the 38% and 43% decrement in performance found by Holland at 0.12 and 0.16 Rms'g' respectively.

Schohan et al. who simulated a three phase mission found that there was a tendency amongst subjects to crash and to become vulnerable to missile attack in the most difficult phase. During this phase the standard deviation of their altitude error rose systematically to equal 152ft. the value of mean error modulus at the highest vibration level. Rms'g' at this level reached 0.4 and subjects reported that control was difficult due to 'jarring' of vision and tenseness of muscles. Relative to the criterion altitude of 500ft. their performance (assuming that altitude error was normally distributed) was such that they spent 16% of time below an altitude of 348ft. No details were given by Schohan et al. concerning the distribution of altitude error and the number of crash events. Consequently it is not possible to evaluate their 'tendency' to an extent greater than their qualitative statement will allow. Performance of aerial observers was found to be slow and inaccurate but the effect was not attributable to vibration parameters.

Altogether 14 secondary tasks were used in the 5 simulation studies. Of

Holland (1966)

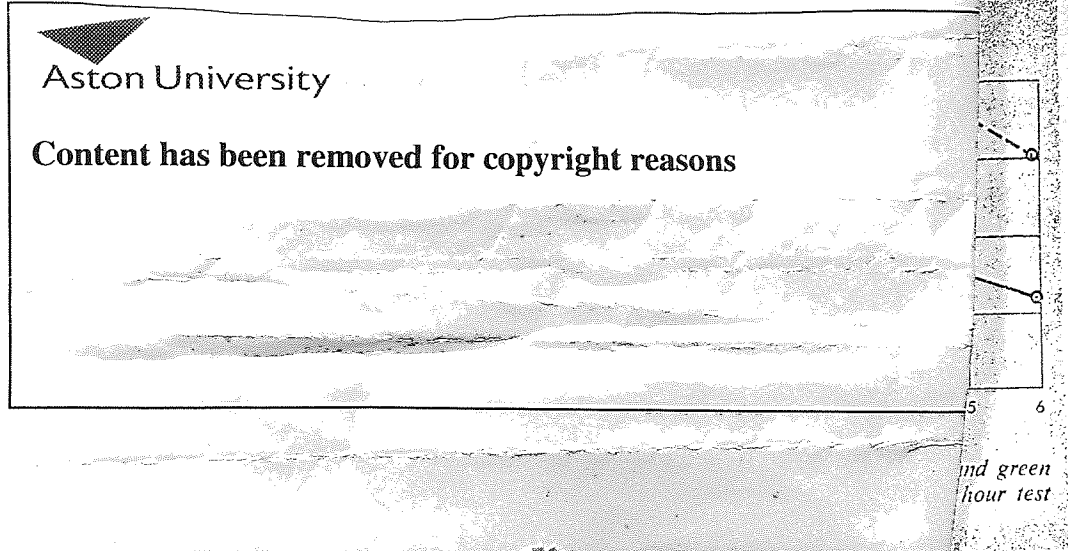

Hornick & Lefritz (1967)

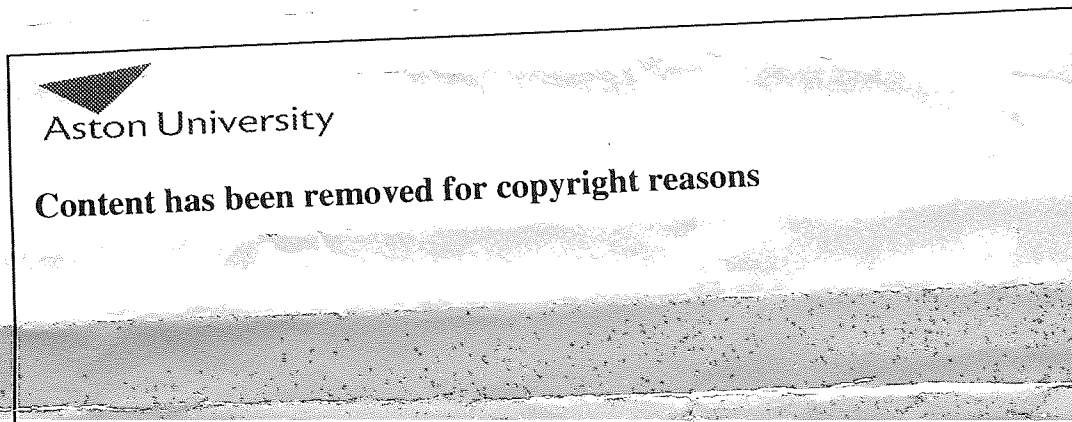
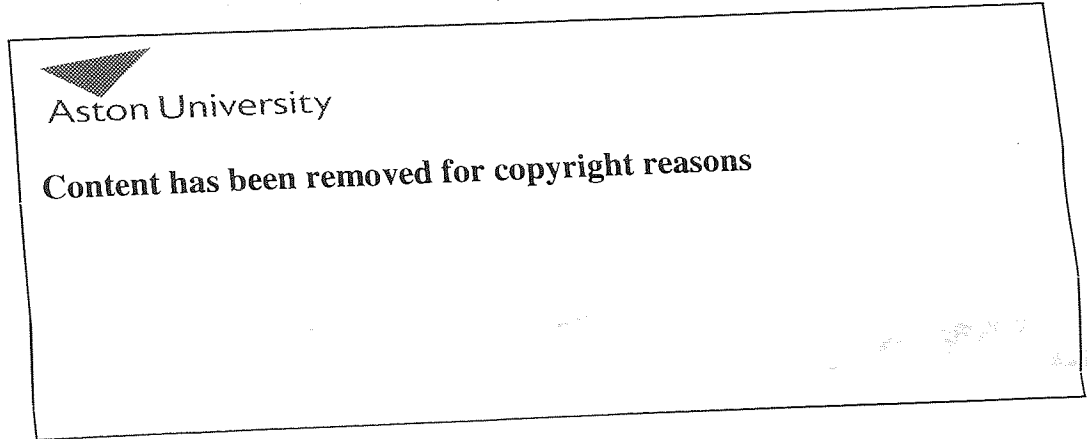

the fourteen only 3 were effected by LAHSF vibration. Performance decrement was recorded by Schohan et al. in response to their ECM warning light and Hornick and Lefritz found that reaction time associated with their thrust management (vigilance) task was similarly effected. This result is shown in Fig.2.7. It is important to note from this figure that decrement in pilot 'vigilance' response time was related to the presence of vibration only. The effect, it is seen, is not related in any systematic manner to vibration intensity. Ignoring the exaggerated effect in the middle of the test at 0.20 Rms 'g' reaction time to a change in thrust command rose from 2.4-7.9 secs., a decrement of 216%. Response times to the red and green warning lights used by Holland exhibit a contrasting effect between the vibration spectral conditions. Vibration contrived so that peak power was centred on 2c/s. gave rise to a small increment in reaction time performance at 0.12 Rms 'g'. The vibration with peak power at 5c/s. showed an almost equal and opposite effect. The result is shown in Fig.2.8.

Reaction time to a single warning light placed in the central vision area was typically unaffected by vibration. The Schohan et al. result is the exception, but they found a decrement only at the peak vibration levels (0.4 Rms 'g'). A result typical of the secondary auditory tone test used by Holland, the master and fault condition lights used by Soliday and Schohan, the electronic target sensor light and for the most part the ECM light used by Schohan et al. is shown in Fig.2.8. The result is that of Hornick and Lefritz who found no decrement in pilot reaction time over a 4 hour exposure period and no difference between any of the vibration conditions.



### 2.3.8.1. Duration

Duration of exposure had mixed effects upon performance. No duration effects were found by Soliday and Schohan in any of the studies with which they were associated. Both Holland and Hornick and Lefritz found signs of a slight duration effect upon primary task performance. In the Hornick and Lefritz study, Fig.2.7 this was found to be accentuated by primary task difficulty. Performance of their secondary tasks, however, was not effected by duration but in contrast, Fig.2.8, Holland found that secondary task performance of his subjects was susceptible to duration effects.

### 2.3.8.2. Recovery

Hornick and Lefritz at the end of a 4 hour period of exposure to vibration tested the performance of their subjects under static conditions. The result shown in Fig.2.7 and Fig.2.8 show that primary task performance continued to decline after vibration exposure. In contrast secondary task performance recovered completely. This finding is consistent with their general result that secondary task performance only was effected by vibration.

### 2.3.8.3. Task difficulty

In four of the studies primary task difficulty was a major experimental factor. Soliday and Schohan (1964, 1965) and Hornick and Lefritz varied the terrain to be followed from flat to hilly to mountainous. Schohan et al. used the same characteristics throughout but varied the speed of

flight. In each case the result was the same. An increase in difficulty caused a related decrement in terrain following ability. Of all contributing factors difficulty was found to have most effect on control capability. This fact is immediately apparent in the results presented by Hornick and Lefritz. Concomitant with an increase in difficulty the results show an increasing fatigue effect. Comments made by subjects confirm that the control task was made more difficult by severe vibration, but their subjective impression was not reflected in their primary task results. Primary task performance was not impaired in a manner such that blame could be pinned on vibration which suggests that subjects were compensating in some way. By responding to the requirements of the secondary task, only when it was convenient from the point of view of the primary task, subjects were perhaps able to maintain their terrain following accuracy. It is also likely that some of the difficulty was offset by a rise in effort or arousal.

#### 2.3.8.4. Tracking Axes

Assuming that display and control movements are compatible we would expect that vertical vibration would have more effect on ability to track a target moving on the same vertical plane than it would a target moving laterally in the horizontal plane. Holland, the only author in the group to express his results separately in terms of horizontal and vertical error comes up to expectation in Fig. 2.7 with a difference of 33% between axes.

### 2.3.8.5. Physiological Effects.

Heart and respiration rate were reported by Soliday and Schohan (1964) and Hornick and Lefritz. In both studies heart rate was found to fall steadily with time. For the latter authors this decline (which may be typical of the other studies) is shown in Fig.2.8. The heart rate descent is approximately 2.5 beats/min./hr. The average for subjects in the other study was approximately 8 beats/min/hr.. In neither study did heart rate appear to be adversely effected or related to intensity of vibration. Indeed, at the lower intensity of vibration, 0.1Rms'g' in Fig.2.8. it appears that the effect of vibration was to cause mild physiological arousal.

Respiration rate as measured by Hornick, Fig.2.8 was responsive to neither vibration nor experimental conditions. In contrast the other authors report a respiration rate which dropped from 24 to 8 breaths/min. over a 1½ hr. period.

### 2.3.8.6. Vibration Spectrum

Holland made a point of testing the effect of two vibration spectra. In both the spectral profile was triangular in the range 0-6Hz.. Analysis of variance of the main study data in which the position of spectral peak was a factor indicated that the position of spectral peak was not significant in its effects. Not content with this result however, Holland conducted a supplemental study with which he was able to show a significantly greater decrement ( $P < .01$ ) when the peak was at 5Hz. than when it was at 2Hz.. 5Hz. is of course the frequency of major body

resonance and consequently the frequency of least tolerance and least comfort. At 2Hz. vibration is well away from the resonant frequency. On these grounds it is to be expected that vibration power centred on 5Hz. would cause more task interference than the same power centred on 2Hz..

#### 2.3.8.7. Stationary v Non-stationary Vibration.

In the three studies with which Soliday and Schohan associated vibration was non-stationary with respect to the duration of exposure which varied between 1-3hrs.. Compared to the stationary vibration studies no effects on manual control performance can be attributed to these different types of random vibration. It would appear from the results that rapid changes in the Rms 'g' characteristic causes no unusual effects and that it is within the capability of experienced pilots to adapt to such changes- indeed such adaptation may be regarded as an essential feature of manual control skill.

#### 2.3.8.8. Closed Loop Vibration

The non-stationarity referred to above was caused by a coupling between A/C altitude and vibration intensity. The former, being under manual control, effected the latter when pilots were unable to maintain the criterion altitude. Analysis by the authors revealed that pilot errors resulted in themselves experiencing, on average, 17% greater vibration intensity than they would have in the case of autopilot control.



### 2.3.8.9. Summary

Five studies have been examined in which, with one exception, tasks and experimental conditions were chosen to simulate those found in Low Altitude High Speed Flight. Collectively the studies provide evidence of the effect of single axis vertical random vibration on the ability of mainly experienced pilots to perform a primary two dimensional tracking task combined with two or more secondary adjustment or monitoring tasks.

Authors used a variety of vibration intensities in the range 0.1 to 0.4 Rms'g' and it is important to note that in three of the studies it was Non-stationary with respect to the duration of exposure. All subjects were vibrated in the sitting position and all were restrained by some form of harness. In most cases a full torso harness was used. All displays and controls were mounted on the moving base of the simulators and all secondary visual displays were placed in the central or near peripheral vision area. Periods of exposure to the vibration varied between authors in the range 1 to 6 hours. The major findings were as follows :

1. Task difficulty was the most effective factor. Authors who varied the difficulty of the primary tracking task found that it had more effect upon performance than either vibration duration or individual difference.
2. Primary task performance was generally resistant to vibration effects. In only one study did vibration effect performance of the primary task. The study concerned was the odd one out in terms of its simulation, subjects, duration and vibration.
3. Three out of fourteen secondary tasks were effected by vibration.



Reaction time to a warning light was impaired at 0.3-0.4 Rms'g'

Response time to one out of three red and three green warning lights increased 4% at 0.16 Rms'g' and decreased by the same amount at 0.12 Rms'g' when, at 2Hz., the frequency of vibration was away from body resonance. Mean response time to a thrust command indicator increased by 216% at 0.1, 0.15 and 0.2 Rms'g'.

4. At levels between 0.05 and 0.4 Rms'g' no effects attributable to vibration were found on an aerial observation task, a pilot visual search and target recognition task, pilot reaction to navigation requests for new headings, response to an emergency warning light and time taken to locate a fault indication.
5. Pilot reaction time to an electronic countermeasures warning light was shown to be insensitive to vibration up to 0.2 Rms'g'. At 0.4 Rms'g' reaction time was found to be increased from approximately 1 sec. at the lower levels to 4 secs. at 0.4 Rms'g'.
6. Detection of change in an auditory tone was unaffected by vibration at levels up to 0.16 Rms'g'.
7. Decrement in response to a Thrust command indicator was independent of vibration intensity.
8. Primary task performance was generally unaffected by duration of performance or exposure to vibration. Fatigue effects appear to be related more to task difficulty than to vibration intensity. In those studies which varied both primary task difficulty and vibration intensity fatigue was shown to be insensitive to the latter.
9. Subjective impressions were that vibration at levels between 0.3 and 0.4 Rms'g' made control difficult due to jarred vision and tenseness of muscle. The latter leading to muscular fatigue.

2.3.8.10. Assessment. Primary task effects.

The evidence is that in one study a 38-43% decrement in primary task performance was observed. In another a tendency to crash was noted at vibration levels between 0.3 and 0.4 Rms'g'. A 216% decrement in performance of a secondary task and a small 4% decrement opposed by a 4% increment at 0.12 Rms'g' were noted. The only other effect found in a secondary task was an increase in reaction time to a warning light at levels between 0.3-0.4 Rms'g'. The evidence is therefore 5-1 in favour of no primary task effect and slightly less than 5-1 in favour of no secondary task effects.

Examination of the primary task result in disagreement with the majority has revealed that differences in subject skill, vibration characteristics and primary task difficulty could account for the disparity. If we dismiss this result on the grounds that it is non-representative we are left with little or no reason to suspect that the effect of random vibration is to cause decrement in the performance of two dimensional tracking tasks of the type found in Low Altitude High Speed aircraft.

Secondary task effects.

Turning now to the effect on secondary tasks it is reasonable to assert that serious decrement was found only in performance of a thrust management task. A rather mystifying feature of the large 216% increase in response time to a change in command indicator position was the fact that it was independent of vibration intensity. The same effect was found at 0.1, 0.15 and 0.2 Rms'g'. The particular task involved first detecting a change in the position of a command indicator and then making adjustments with a left

hand throttle control until 2 pointers were aligned. Reaction time to the change was the only score used to describe what was in fact an adjustment task requiring a good deal of manual dexterity. To satisfy this requirement it is expected that the operator would need to transfer a majority of his visual attention to the thrust indicators and switch to consideration of left hand movements. In this case the decision to respond was probably a combined function of how well he was coping with the primary task and how successful he perceived he would be if he was to take action at the instant of detection. Ignoring any effects due to perceived priorities, the plausible explanations seem to be : That either involuntary hand movements were interfering with manual dexterity, or that the primary task was made more difficult by the vibration, providing less opportunity to switch attention without incurring primary task penalties. On the other hand if priorities were with the primary task then it is hypothesised that increased response time was the reflection of a deliberate 'wait and see' control policy suggesting that subjects 'would not' rather than 'could not' perform.

#### 2.3.8.11. Conclusion.

The assessment overall is that the simulation studies have shown that skilled operators can resist or adapt to severe random vibration (0.3-0.4 Rms 'g') to an extent which enables them to perform terrain following manoeuvres for periods up to 6 hours without performance impairment. Implied in this process of adaptation is the quick learning of new control, visual reading and comfort techniques, the psychological conditioning process whereby a subject learns to become less anxious and physiological conditioning in which muscles used in tensing the body under high 'g' levels become affective in enabling the operator to perform with greater ease.

As a consequence of maintaining primary task performance the studies suggest that time sharing ability was impaired. That operators were less vigilant in attending to some of their secondary task duties (perhaps as a deliberate policy) and that specifically response is significantly delayed when the secondary task involves fine manual adjustment. From the practical point of view the above hypothesis, if it is true, provides grounds sufficient for thinking that the results may not be applicable to the operational situation which was the object of the simulations.

#### 2.3.9. Related simulation and random vibration studies.

In this section further evidence is presented concerning the effect of vibration on man as a controller. Seven studies have been analysed in order to test and to extend as far as possible the conclusive statements concerning the effect of simulated random vibration on human performance. Four of the studies examined were carried out using the British Aircraft Corporation Dynamic Manned Vehicle Simulation facility, formerly the TSR-2 simulator. These studies were all concerned in some way with problems associated with ground effects arising from low altitude, high speed flight and/or the long nosed configuration of supersonic transport aircraft, Such aircraft, it was anticipated, would expose pilots to vibration in a combination of axes of which it was thought that lateral vibration would present more of a problem, from the manual control point of view, than the associated vertical vibration. Consequently these studies all feature the use of lateral and multi-axis vibration as well as the more usual vertical vibration. The vibration was periodic (near sinusoidal) rather than random vibration whose amplitude and frequency were chosen to reflect predicted air frame response to runway and aerodynamic effects rather than their random

TABLE 2.4 RELATED RANDOM VIBRATION STUDIES

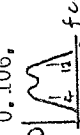
AUTHOR	VIBRATION	EXP. COND.	TASKS	FINDINGS
Lark C C (1962)	Rms 'g' 0.15, 0.35 and 0.50 with peak level resp. 0 to 2.5 g., - 1.2 to 4g. - 2.5 to 5g.	14 highly motivated skilled naval pilots. Aircraft seat; Torso harness. Duration 15 - 30 min.	Two dim. comp. tracking.	Performance decrement 6% at 0.15 14% at 0.35 19% at 0.50
Hurt (1963)	Rms 'g' 0.16, 0.333, 0.329 Gusts 1 per sec at 0.329, 2.5/sec at .385, 1.4/sec. at .948 Rms 'g'.	NASA normal accel. facility. Torso harness 'firm' seat duration 11 - 14 mins.	Aerial observation instrument recording, course plotting, sight testing.	At 0.948 Rms 'g' observer disrupted but not stopped from performing. freehand drawing legible, sight impairment 55% at 0.948 Rms 'g' relative to 0.329 Rms 'g'.
Parks D L and Hickey L F (1965)	Non Stationary Vibration Rms 'g' 0.175 for first hour 0.185 for 2nd " " 0.175 for 3rd " " 0.205 for 4th " "	6 operators; duration 4 hrs or less, dependant upon subject tolerance.	Primary terrain following 2D. comp. tracking. Secondary tasks. 1. compass reading control, 2. warning lights, 3. reading digits (expt. was a tolerance test).	3 out of 6 subjects asked to terminate during vibration, 2 during no vib. tests. Primary decrs. 60% after 1 hr, 87% after 4 hrs. 2nd task decr. 35% after 4 hrs. Warning lights - no effect. digit reading - no effect.
Weisz A Z Goddard C J Allan R W (1965)	Rms 'g' 0, 0.035, 0.106, 0.177, 0.212 PSD  f c/s 0.035 5% 1 min tol. 0.106 15% 1 min tol. 0.177 25% 1 min tol. 0.212 30% 1 min tol.	Hard seat, rigid student desk and shoulder harness, duration 30min.	As for Holland (1966) but with high and low task difficulties and with and without secondary task.	Primary task, 12 - 28% 0.035 Rms 'g', 14 - 28% 0.106 Rms 'g', 16 - 33% 0.177 Rms 'g', 38% 0.212 Rms 'g' Primary easy/diff 4% at 0.177 Rms 'g'; With/without secondary task 6%. No duration effects. No secondary effects.

excitation characteristics per se. At the time when the studies were conducted motion fidelity problems were causing contamination of the sinusoidal motions which in some cases resulted in rather random looking vibration waveforms. The virtue of these studies and the main reason for their inclusion in this review was the realism with which manual control was studied. The simulator was based on the actual aircraft cockpit, which meant that experienced pilots, familiar with such work places, were able to use their normal cockpit routines. The motions were multi-axis approximating closely those found in real aircraft. With one exception tasks were presented on actual aircraft displays and a spherical dome and projection system provided good simulation of the external visual field in terms of horizon and ground features. In respect of their realism these four studies constitute a unique set in the available literature. Together with the other studies in this part of the review experimental details are given in Tables 2.4 and 2.5. The three other studies listed in Table 2.4 were associated with similar aircraft vibration problems but their research objectives were different. The study by Weisz et al. (1965) was research conducted to evaluate the effects of comparable random and sinusoidal vibration. The Parks and Hickey study (1965) was a 4 hour endurance test and the study by Clark (1962), being one of the earlier random vibration studies, may be regarded as a pioneering effort in this type of research. Single axis vertical random vibration was used by the above three authors. Four out of 7 studies involved the use of primary plus secondary tasks, the remainder being single two-dimensional compensatory tracking tasks. There were again differences in the stationarity characteristics between studies but in all seven cases vibration characteristics were independent of the control task unlike the Soliday and Schohan studies examined

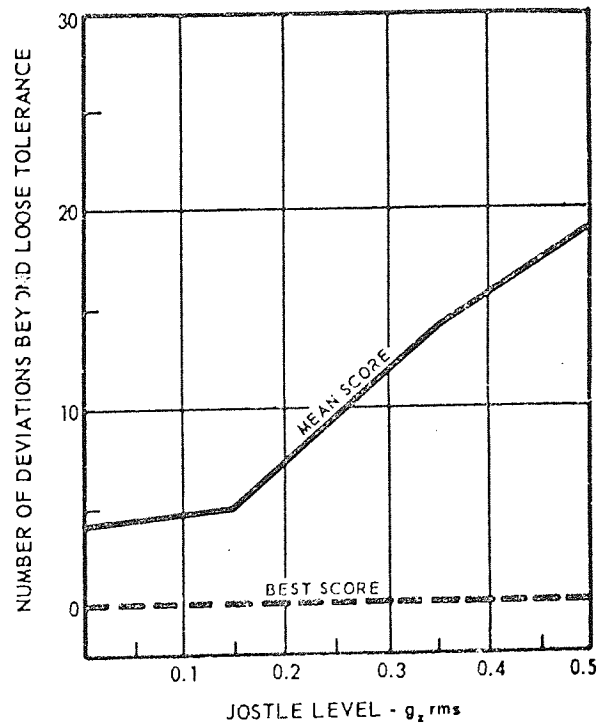
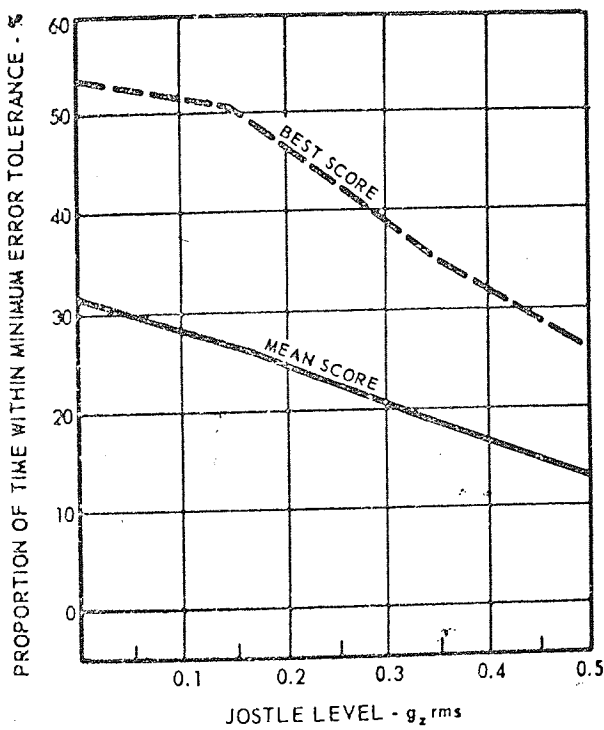



previously, where pilot error influenced vibration intensity.

#### 2.3.9.1. Tasks, experimental conditions and results.

In the earliest study, listed in Table 2.4, Clark (1962) measured 2 dimensional tracking performance at three levels of random vibration; 0.15, 0.35 and 0.50 Rms 'g'. Subjects were highly motivated skilled naval pilots who managed to perform the demanding control task for periods said to be between 15-30 mins.. Subjects were seated and harnessed, the latter being an essential feature for performance in an environment which at its most severe reached peak acceleration levels of -2.5 to +5.0 'g'. The results shown in Fig.2.9 are expressed as a mean and best score. At best it is shown that pilots were able to stay within what were described as loose tolerance margins at all levels of vibration but their average performance was found to decline with increasing vibration intensity. At 0.15 Rms 'g' decrement was 6% compared to the no vibration condition; at 0.50 Rms 'g' it reached 19%.

In a study previously examined, Schohan et al. (1965) simulated aerial observation tasks. Hurt (1963) did likewise but not in association with manual control tasks. Hurt tested observers at four random vibration levels 0.16, 0.335, 0.329 and one unusually high level, 0.948 Rms 'g'. Another unusual feature of this research was the use of the Gust frequency as an independent variable. At 0.329 Rms 'g' gusts were applied at a rate of 1 per second, 2.5 per sec. at 0.335 Rms 'g' and 1.4 per sec. at 0.948 Rms 'g'. Gusts were not defined by the author but it seems reasonable to assume that the maximum acceleration levels associated with the Rms 'g' statistics occurred at intervals equal to the gust



Freehand Drawing Ability During Vertical  
Random Vibration (After Hurt 1963)

Figure 2.10

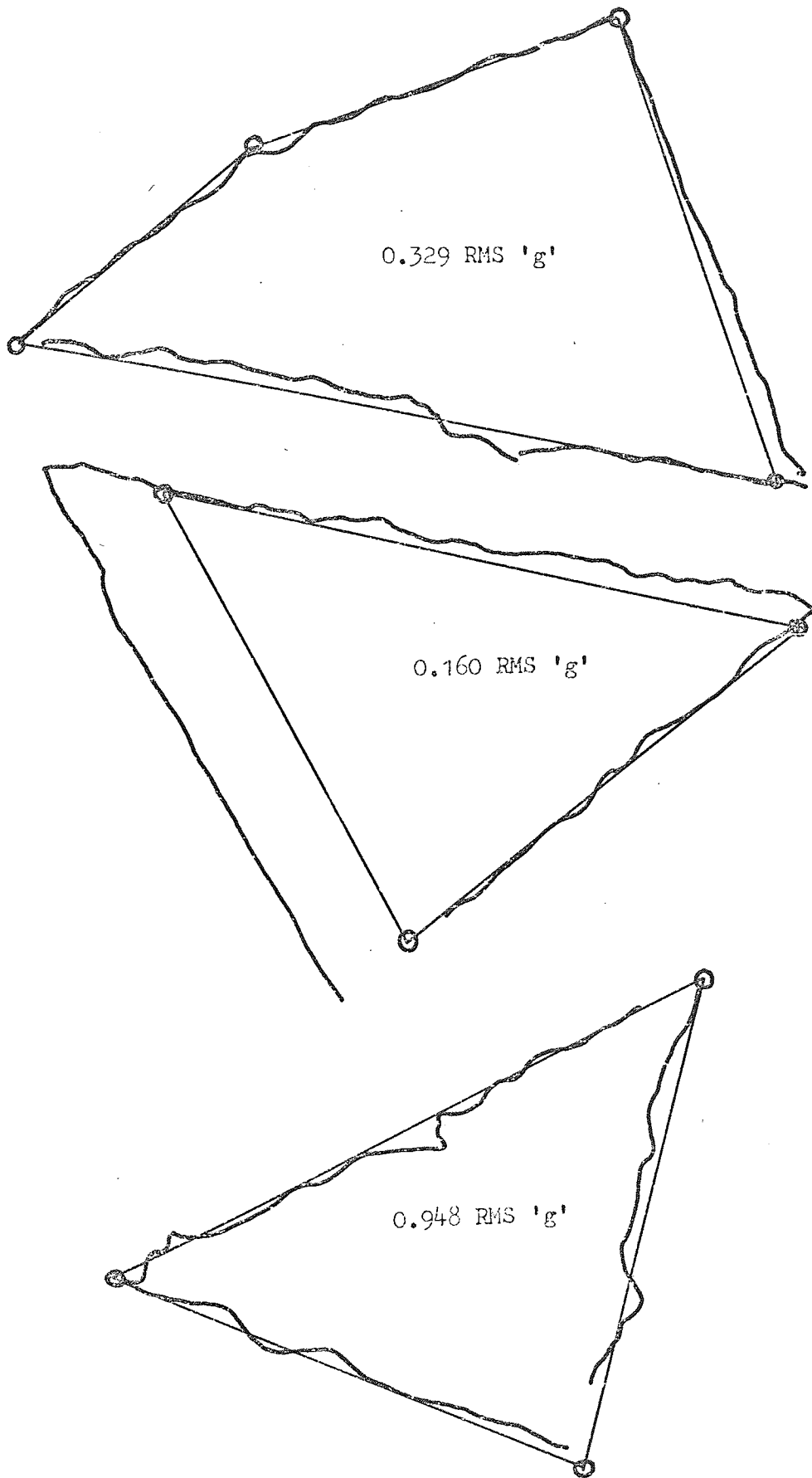

period. The gusts and vibration were generated by the NASA Normal Acceleration facility. Subjects were sat on a firm seat and wore a full torso harness.

During exposure ranging from 11-14 mins. experienced aerial observers (navigators) recorded instrument readings, calculated the r course and arrival times, plotted the course by hand on a navigators pad and carried out sightings as a part of a sight test.

Hurt found that subjects were 'disrupted but not stopped from performing their assigned tasks'. Examples of freehand drawing ability are shown in Fig.2.10. It is extraordinary that such legibility was attainable at the levels involved. The results suggest that freehand drawing was very little affected by the extremely high vibration levels but it may have been that the skilled subjects were using some form of anticipation acumen to mitigate the effects. Sight tests indicated that a 55% increase in visual angle was required to combat the effects of blurr at 0.947 Rms 'g'. No measurements were made without vibration present but absolute performance measures tend to confirm the Schohan findings that severe random vibration has little or no effect on the ability of aerial observers to perform their tasks - albeit slowly.

Ability to perform and willingness to tolerate simulated LAHSF vibration was investigated by Parks and Hickey (1965). "Each of six operators was required to perform continuously at a high level of effort until 1 of 3 conditions was satisfied :

1. He did not want to or could no longer continue.

Primary Terrain Following and Secondary  
Compass Tracking Task Performance during  
a 4Hr Exposure period at 0.17-0.205 RMS'g'. Parks & Hickey(1965)

Figure 2.11

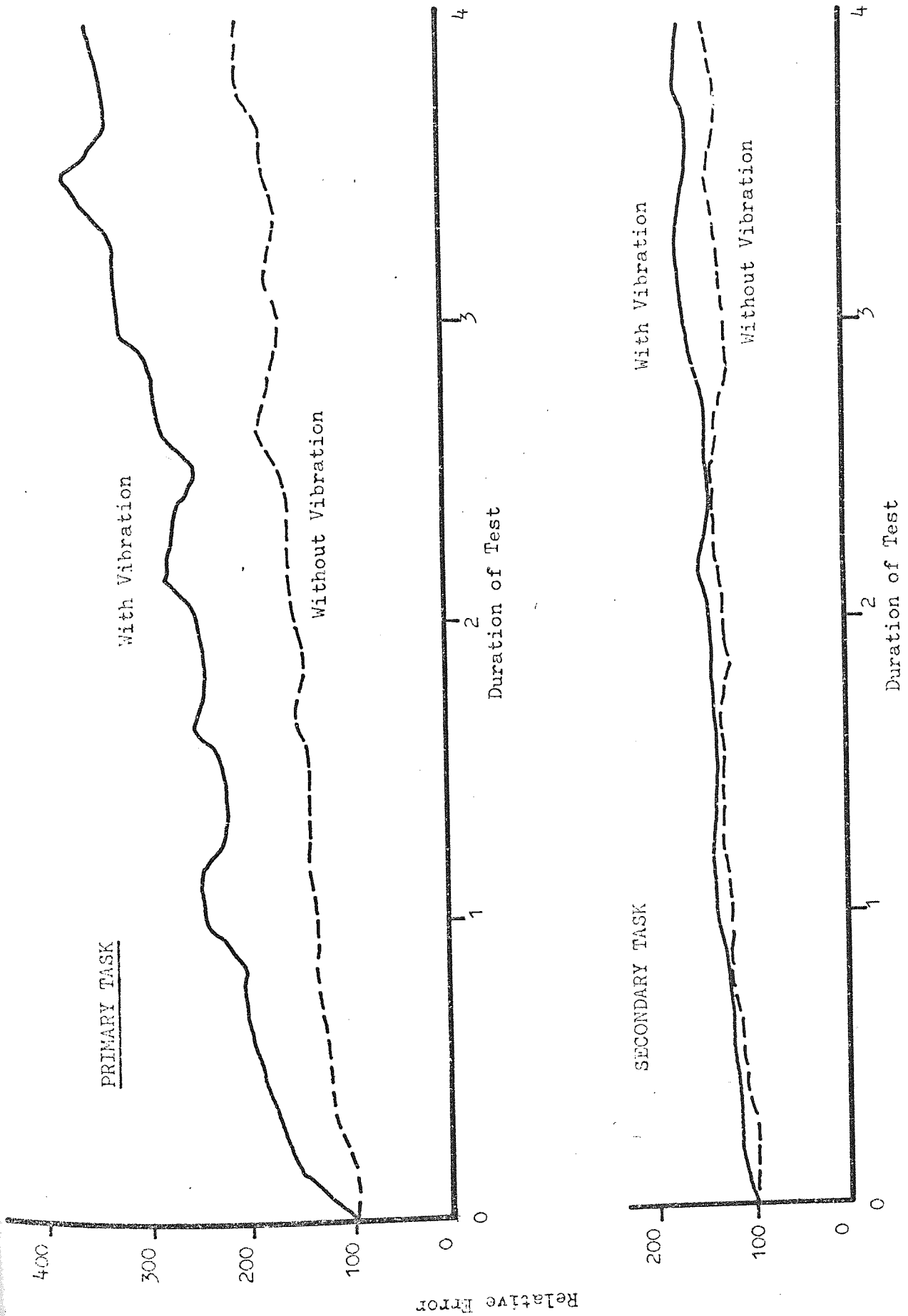

2. Performance was considered ineffective according to a pre-determined criterion.
3. Four hours of testing was completed.  
subjects were not aware of the 4hr. limit.

The primary two dimensional terrain tracking task was purposely made difficult by the authors by the addition of double integration with a 2sec. time constant between control and display movement. Three secondary tasks were added to this very difficult primary task. The first, a compass heading task, required that subjects keep track of heading by making adjustments on command and by holding course in spite of random changes in heading. To make this task more difficult than usual a single intergation with a 0.67 time constant was introduced between the minor control and compass display. The two other secondary tasks involved reacting to warning lights, calling out the presentation appearing on 1 of 5 counters each with 5 digits featuring different digital size. Altogether an onerous task by any standard. Rms'g' levels fluctuated during the 4hr. period. During the first hour they averaged 0.175 Rms'g', 0.185 during the second and 0.175 and 0.205 in the 3rd. and 4th. hours. The tests resulted in 3 out of 6 subjects terminating during vibration with two terminating during the no vibration test. Terminations during vibration occurred after 150, 165 and 175 mins. and similarly without vibrations.

The performance of three subjects who were able to sustain the task for the full 4hrs. is shown in Fig. 2.11. Relative to the no vibration condition their primary task performance shows a gradual decline culminating after 4hrs. in an error of 87%. No decrement was found in performance of the warning light and digit reading task but a decrement

Vertical Tracking Scores during Performance  
with a Secondary Task and Random Vertical  
Vibration ( After Weisz, Goddard, Allen 1965)

Figure 2.12

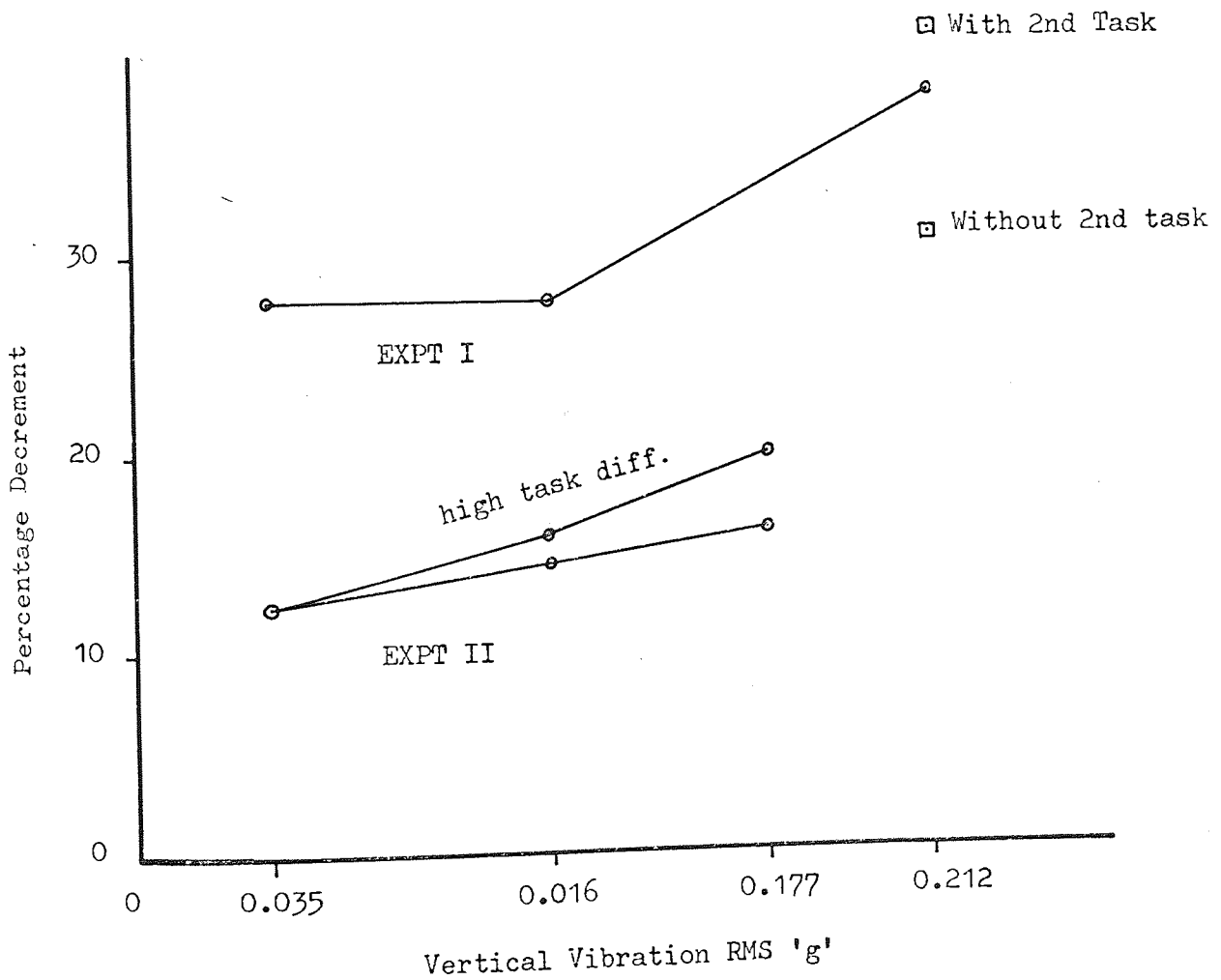

of 35% was recorded after 4hrs. performance of the heading task. Subjects who dropped out did so voluntarily, more because of tiredness associated with the task rather than with vibration.

Research by Weisz, Goddard and Allen (1965) was carried out with the object of comparing performance effects due to 5c/s. sinusoidal, 5c/s. amplitude modulated and 1/2-12c/s. Random vibration was equated on the basis of Rms 'g'. Both research equipment and task were identical with those used by Holland (1967) (see Table 2.3). Vibration levels were 0.035, 0.106, 0.177 and 0.212 Rms 'g'. According to the authors these levels correspond to 5, 15, 25 and 30% of the 1 minute tolerance level found by Nagid and Coermann (1960). For their study Weisz et al. used both difficult and easy versions of the 2-D comp. tracking task described by Holland and subjects were tested with and without secondary tasks in two separate experiments each lasting 30mins. Subjects were said to be familiar with simulator flying and their performance under the influence of random vibration is shown in Fig. 2.12., Fig. 2.12 has been re-drawn from the Weisz data in order to express the average effects in terms of per cent. decrement relative to performance without vibration. In their first experiment the authors found decrements in the range of 12-28% at 0.035 Rms 'g', 14-28% at 0.106 Rms 'g' and 16-33% at 0.177 Rms 'g'. Between high and low task difficulty there was a 4% difference at 0.177 Rms 'g' and in their second experiment decrement at 0.212 Rms 'g' was found to be 38.2%.

By comparison with results obtained by Holland, with the same equipment, the random vibration in the Weisz study was very similar in its effects on primary task performance, Secondary task performance followed a

similar pattern. No changes were found in performance of the Auditory Vigilance task and only slight interference with the red and green warning light task was noted. On the whole the findings of these two authors are in good agreement for the case of random vibration. Statistical significance was found to exist only between no vibration and performance at 0.177 Rms'g' and between 0.035 and 0.177 and the higher level of 0.212 Rms'g'.

Between 1965 and 1968 a series of tests were carried out by the Royal Aircraft Establishment, Farnborough, using as a means the five degree of freedom TSR 2 Simulator situated at the British Aircraft Corporation, Weybridge Centre. Of relevance to this review, for reasons given earlier, are the studies reported by Harwood and Lovesey (1966), Harwood, Lovesey, Rowlands and Allen (1968) and Lovesey (1970). Lateral, combined lateral and vertical as well as vertical vibration was studied. For the sake of convenience a full description of the experiment will be given for each study together with the findings associated with each axis and each combination.

In the first study reported Harwood and Lovesey (1966), five subjects were used in an experiment involving 10 days of testing and 32 conditions per subject. The independent variables included two vibration types - sinusoidal and amplitude modulated sinusoidal vibration ; vertical, lateral and combined vertical and lateral axes ( referred to by the authors as Heave and Sway respectively); frequencies of vibration in the range 1.5-4.0Hz. and vibration intensities in the range 0.15-0.3Rms'g'.

Two tasks were used and these were performed in separately assigned intervals. The first a 2-D comp. tracking task using a head-up display

TABLE 2.5 MULTI AXIS VIBRATION

AUTHOR	VIBRATION	EXP. COND.	TASKS	FINDINGS
Harwood K G Lovesey E J (1966)	Sin. and Mod. sin. Vert. 0.15 - 0.3 Rms 'g' 1.5 - 4 Hz trans 0.15 Rms 'g' 2 - 5 Hz. v & t 0.25, 2 Hz 0.15, 2.5 Hz	5 sub. of various experience. duration 5 mins. each sub. 32 condit. 10 days. 3 1 min tracking 2 1 min. secondary ejection seat - head full harness, soft leather.	Primary 2 - D comp tracking head-up display, stated to be not most diff. a pilot could expect. second task read- ing six instrument settings	Primary task, no impairment. Some incre. av. vert incre 9% one decr. 9%, some no change. max. vert. incre. 17.5% lat. no incre. decr. of 9% secondary task - at 4 c/s. 0.45g. vert. and 0.25g lat. instru- ments difficult to read.
Shurmer C R and Silverton D G (1967)	Near sin. vert., lat roll. 2.4 Hz. vib. axes imposed individ. and in combination. Rms 'g' 0.0425 - 0.35 roll $\pm \frac{1}{4}^0 \pm 3^0$	Two types of control. 1 spring centred joy. 2 pressure (force con) six naive subjects. typical a/c seat T V display duration 1 minute	2 - D comp, tracking (time on target)	In 20 of 22 cases decr. between 20 - 40% least decr. 11% was vert. vib. at 4 c/s. 0.09 Rms 'g'. most decr. 49% in roll at 4 c/s. $\pm \frac{1}{2}^0$ rank decr. for comb. vib. related to total energy input (Shurmer has equation). 3 axes - 3 out of 4 cases of 3 axes motion had less effect than either same roll or trans. comp. acting alone. 2 axis - greater than single axis. 3 cases, equal in one, less in one.
Harwood K G et al (1968)	Sin. and mod. sin. vert. and comb vert/lat. runway phase 0-0.09 Rms 'g' with 0.28 Rms 'g' at end. climb and cruise phase 2 Hz., 0.24 Rms 'g' 3.5 Hz., 0.13 Rms 'g'	6 subjects, equal noise duration 15½ mins. runway 28 secs. climb 5 mins. cruise 1 5 mins. cruise 2 5 mins.	Sim. Concorde take-off, climb, cruise. Primary tasks. 1 directional control along runway. 2 take-off director tracking. 3 head-up comp. tracking task. Secondary task. 1. warning light reaction time test during climb.	Primary tasks. 1. runway roll, average of 35% decrement comb. vert. & trans. no vert effect. 2. rotation & climb. 60% decr. due to comb. vert. and trans. no vert. effects. 3. cruise phase. slight decr. with vert. and trans. vib. no vert effects. Secondary tasks. 1. no effects on reaction time to warning lights. 2. as 1 digits impossible to read with vert. and trans. vib.



Harwood & Lovesay (1966) Tracking Performance  
 During Vertical, Transverse, & Combined V + T.  
 Sinusoidal Vibration

Figure 2.13

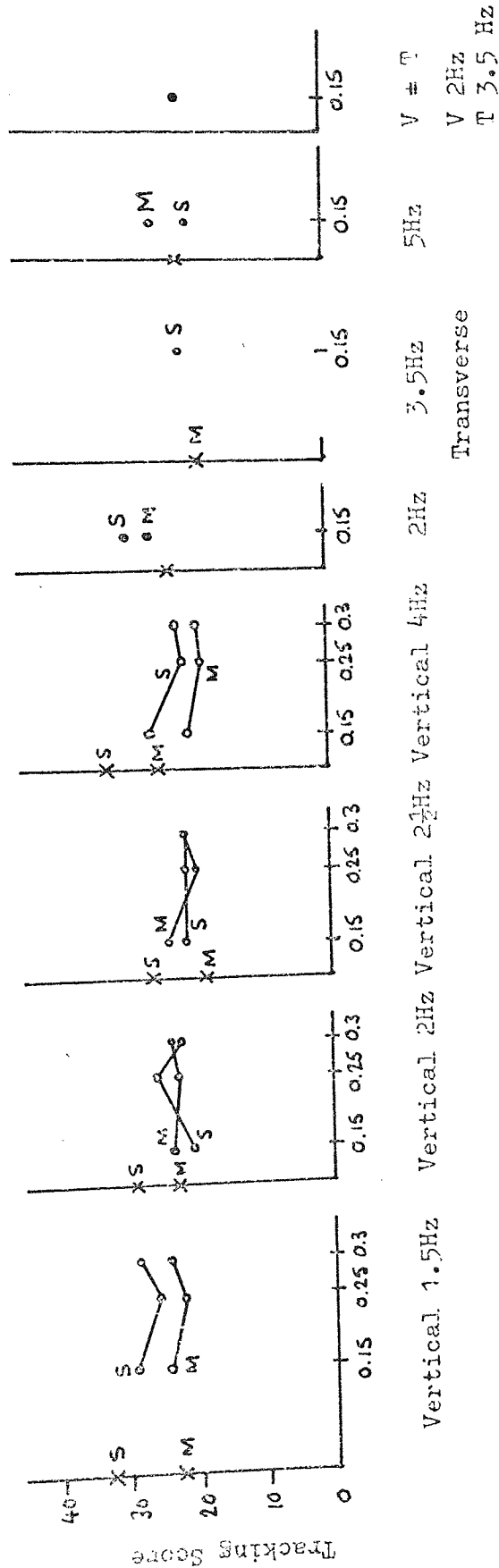

was performed first for three minutes in a 5 minute trial. For the remaining two minutes subjects switched their attention completely to the head down instrument panel where they were required to read off six instrument settings. Unfortunately the authors failed to obtain results from all subjects for all conditions but what was obtained for the principal task is shown graphically in Fig.2.13. For the vertical vibration condition it was found, in 7 out of 9 cases which were cross checkable with the zero vibration condition, that performance improved under vibration. In one case it was the same and in another it was less by 10%. Improvements ranged from 1-17% with an average of 9%. Under vertical vibration the results in Fig.2.13 show a slight tendency for tracking errors to be greater at 4c/s. - a surprising result - with lateral vibration at 2c/s. causing no more decrement in performance than vertical vibration at  $1\frac{1}{2}$ c/s.. For lateral vibration only two results were crosschecked with the 'lateral no vibration condition'. The result was a decrement in performance of 4 and 16%.

Doubling of vibration intensity from 0.15 to 0.30Rms'g' was found to cause no more effect - either positive or negative - than vibration at the lower level. Neither were there any consistent differences between sinusoidal and modulated sinusoidal vibration at the same intensity levels.

In the second task no instrument reading mistakes were recorded but subjects reported reading difficulties above 0.15Rms'g' and especially when reading under the influence of 5c/s. lateral vibration. This finding presumably led the authors to state in their conclusion that "short range visual acuity--- is impaired in that digits of  $\frac{1}{8}$  inch

high can only be read with difficulty, especially in lateral, lateral and vertical combined and the high amplitude displacements at the modulated mode".

The second report by Harwood et al.(1968) is an account of a Concorde simulation which was carried out by the Royal Aircraft Establishment to evaluate pilot performance during runway control, take off, climb and cruise under predicted vibration conditions. Evaluation was carried out by means of the same five degrees of freedom rig which was programmed to provide pilot subjects with instrument settings, 'out of the window' views, noise and vibration conditions appropriate to the phases of flight, including the important rotation event just before take-off. This event was programmed to occur, upon command, 28secs. after commencement of runway roll. It was followed by a 5 minute climb and then the initial and final cruise phase each lasting five minutes.

During runway roll subjects looked out of the window at the runway image projected on to the simulator dome. The runway task involved steering down the middle of the runway with the aircraft under the influence of lateral disturbance. This task was performed for 28sec. after which time rotation was called for and the subject switched to the take-off and climb task which started at 30secs. and lasted 5 min. The climb task, 2-D comp.tracking task was presented on a head down flight direction display. At the end of climb the simulator levelled out and subjects began another 2-D comp. tracking task presented on a head up display. This task was performed throughout cruise.

Performance during the runway phase was scored in terms of maximum

Effect of Vertical & Combined Vertical & Lateral Vibration on Vertical & Horizontal Tracking(After Harwood et.al.1968)

Figure 2.14

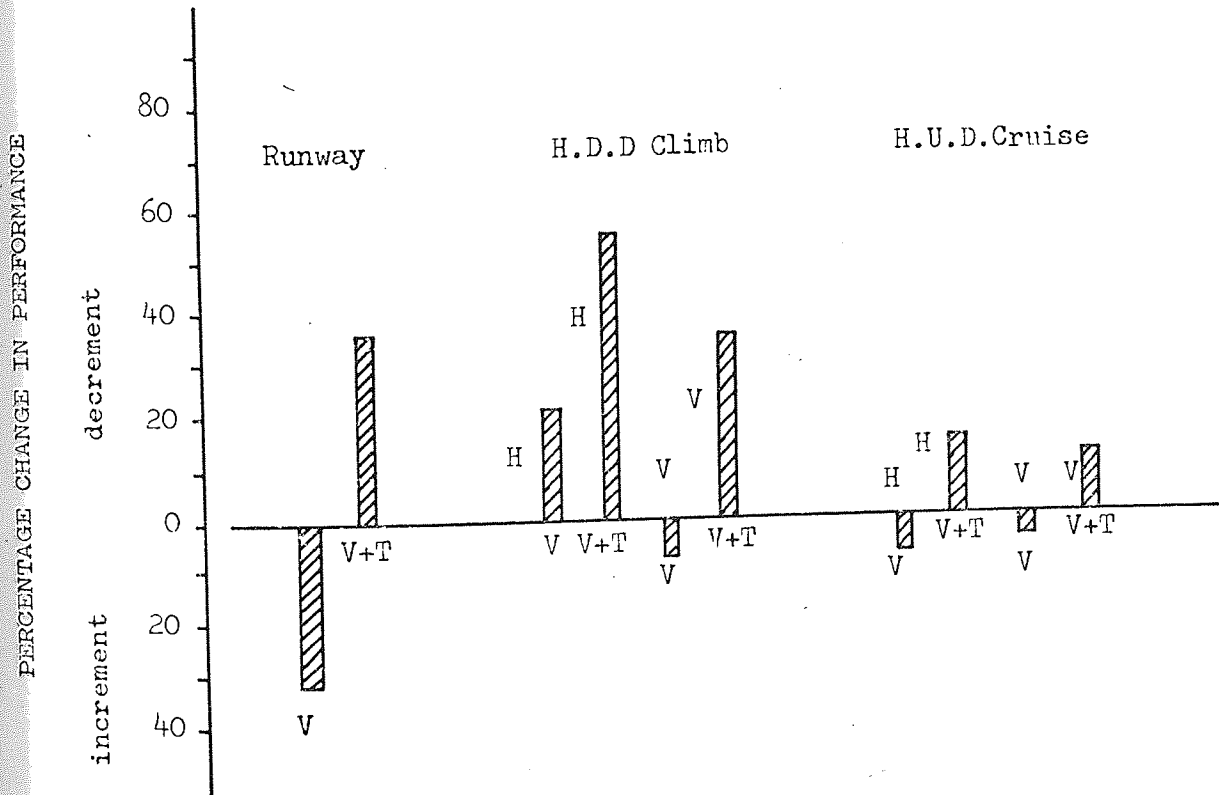

Note 1: Runway result is the sum of percentage decrement for both Max. Excursion and Mean Deviation.

Note 2: Results apply to 2Hz, 0.24 Rms 'g' & 3.5Hz, 0.13 RMS 'g'

Note 3: Symbols above axis denote tracking axes. Symbols below axis denote Vibration axis.

lateral excursions (ft.) mean deviation from centre line (ft.) number of excursions exceeding  $\pm 10$ ft. and number of excursions exceeding  $\pm 20$ ft. Climb performance was scored in terms of the incidence of stall and 2-D tracking error associated with the head down director. During climb a secondary warning light task was performed to give a reaction time score. Performance during cruise was similarly expressed in terms of 2-D tracking errors associated with the head-up display.

From vibration waveforms presented it would appear that vibration during runway roll was programmed to give a non-stationary ride in the range 0-0.09 Rms'g' reaching 0.28 Rms'g' just before take off. During climb and the second cruise phase it was stationary sinusoidal or modulated sinusoidal. Two frequencies were used : 2Hz. and 3.5Hz. with intensities of 0.24 and 0.13 Rms'g' respectively. Vibration having these characteristics was presented along vertical and combined vertical and lateral axes but at no time was it applied during the first cruise phase. When trials were run without vibration, care was taken to equate the noise level with that present during vibration trials.

Results from the three flight phases are shown in Fig.2.14. Expressed as a percentage of performance without vibration they indicate a mixture of increment and decrement in performance under conditions of vertical vibration but decrements only and larger ones under combined vertical and lateral vibration. From the results presented by Harwood et al. it was not possible to differentiate between 2Hz., 0.24Rms'g' and 3.5Hz., 0.13Rms'g' effects and so it has been assumed that the results shown in Fig.2.14 apply to both conditions. Runway task scores present a confused picture. Ability to maintain course during runway

roll, as represented by mean deviation, showed a 37% increment over no vibration performance, whilst ability to stay on the runway fell 20% according to the  $\pm$  20ft. steering tolerance. The scores for combined vibration were a 3% and 140% decrement respectively. Performance of the climb task under vertical vibration rose 7% and fell 21% for the vertical and horizontal components respectively. Under combined vibration it fell 36% and 56% for the same scores. A result in agreement with subject reports that the head down flight director display was difficult to read under combined vibration conditions.

The vertical vibration result for climb surprisingly caused a reverse of what was expected - a greater decrement in horizontal compared to vertical tracking. A nose up attitude was adopted during climb and the odd result may derive from this condition, alternatively it may have been that the horizontal tracking component was more difficult than the vertical.

Performance of the secondary warning light task was not effected by vibration but subjects found it impossible to read ASI digits during combined vertical and lateral vibration. The authors comment that 'performance decrement under combined vertical and lateral vibration was due mainly to reduction in visual acuity associated with the effects of the lateral component of vibration on the eyes and/or instrument! Commenting on the improvement-decrement paradox presented by the vertical vibration condition the authors conclude with considerable justification that 'this underlines the dangers of generalising on the effects of vibration on (tracking) performance and emphasises the importance of the task difficulty in this context'.

Effect of Single & Multi Axis Vibration on 2D Comp Tracking (Shurmer & Silverthorn 1967)

Figure 2.15

V = Vertical Vibration  
 T = Transverse "  
 R = Roll Vibration

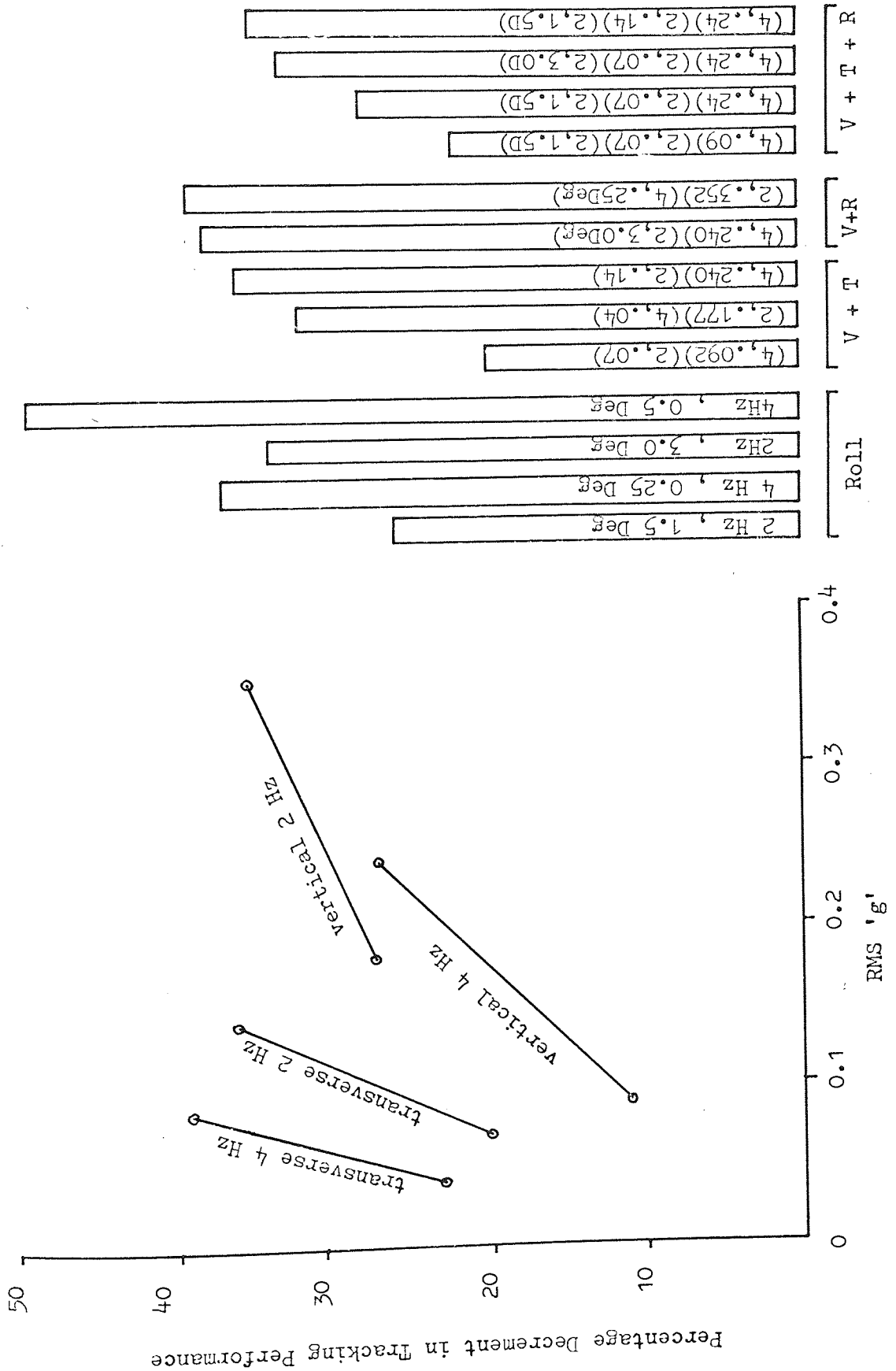

Using the same five degree of freedom simulator Shurmer and Silverthorn (1967) conducted an experiment which involved rotating vibration in the rollaxis as well as translation vibration in the vertical and lateral axes. Selected two way and three way combinations of axes were also studied making in all 22 vibration conditions. Six inexperienced non pilot apprentices were used as subjects for this experiment. The task they performed was a contrived 2-D comp. tracking task developed earlier by Ketteringham and Shurmer (1967) for guided missile studies. The performance score was time on target which was expressed in terms of vertical and lateral tracking axes as a function of performance under no vibration condition.

Vibration was near sinusoidal in all three axes. Vibration at 2Hz. and 4Hz. with intensities between 0.0425 and 0.35 Rms'g' in translation and  $\pm \frac{1}{4}$  degree to  $\pm 3$  degrees in roll were applied individually and in combination. Duration of exposure to each condition was 1 minute and subjects were tested with two types of control - a spring centred joystick and a pressure control.

It was stated by the authors that this experiment was carried out because it had been predicted that lateral vibration would prove to be more of a problem for manual control with slender long nosed aircraft in rough conditions found in take-off, landing, terrain avoidance and weapon delivery than comparable vertical vibration intensities. Their results, Fig.2.15 appear to prove the point. Tracking performance decrement at 4c/s. was about 25% greater at 0.085 Rms'g' under lateral vibration but most decrement at this frequency was caused by roll vibration with an amplitude of  $\pm 0.5$  degree. Unlike Harwood et al.



Shurmer found that all vibration conditions produced performance decrement compared to the no vibration condition. In 20 out of 22 cases decrements were between 20% and 40%. In one case vertical vibration at 4Hz. and 0.08Rms'g' decrement was 11% and the roll condition mentioned above produced 49% decrement. Five two axis combinations were tested. In three out of five decrement was greater than the largest decrement produced by the same single axis vibration acting on its own. This result occurred both times when roll was in combination with vertical vibration. The rank order of effects resulting from the various combination of axes is evident in Fig.2.15. Note that in three out of four cases the triple combination produced less decrement than the same single axis component acting alone. Amongst the combination effects one systematic effect only seems to emerge. This is shown in Fig.2.15 where the combined vibration conditions have been ranked according to the sum of Rms'g' levels and roll amplitude. This finding suggests that performance decrement under combined vibration is related to the total energy of the situation.

On average it was found that the spring loaded joystick control gave 13% better performance than the pressure control under all vibration conditions.

For vertical and lateral vibration the expected result was obtained, that tracking errors were greatest in the tracking axis which corresponded to the vibration axis. Roll vibration caused most errors along the horizontal tracking axis but all combined axis vibration produced errors which were equal in both axes.

A Summary of the Effects of Vertical Vibration on the Performance of Primary Control Tasks.

Figure 2.16

- A Clark (1962)
- B Holland(1967)
- X Hornick (1966)
- D Soliday (1964)
- E Soliday (1965)
- F Schohan (1965)
- G Harwood (1966)
- H Harwood (1968)
- I Shurmer (1967)
- K Weisz (1966)
- M Parks (1965)
- W Whitehead (1972)

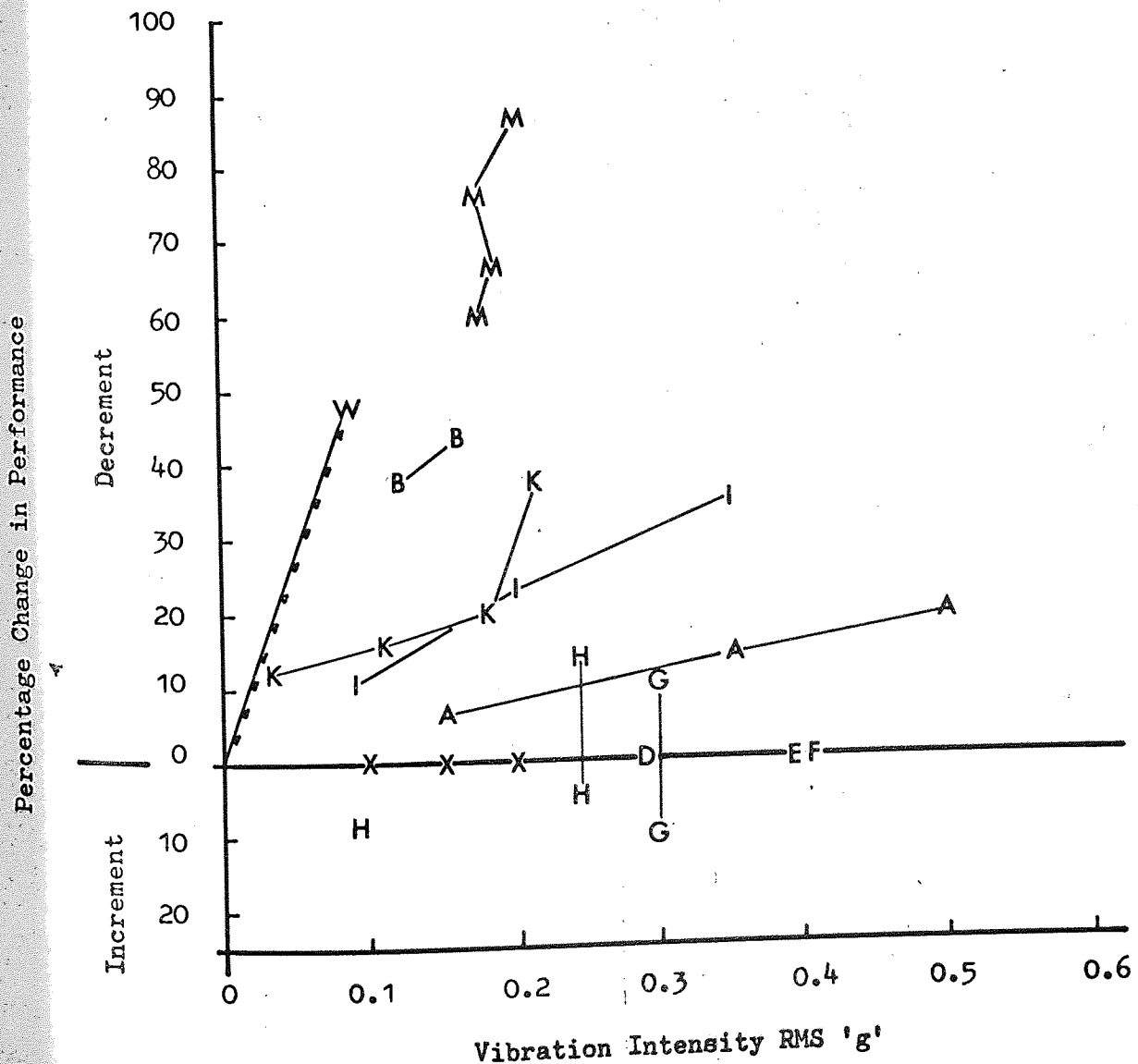

### 2.3.9.2. Assessment

Vertical vibration - primary task effects.

Five experiments in this second group of vibration studies resulted in performance decrement at all levels of vibration. Two studies resulted in better performance and one, an aerial observation study, concluded that navigation type tasks were generally unaffected by severe random vibration. Compared to the previous finding which was 5 to 1 in favour of there being no primary task effects this second group of studies present odds which are 5 to 2 in the opposite direction. Fig.2.16 is a plot of the vertical vibration results including those in the first review. Results above the abscissa in Fig.2.16 represent performance decrement whilst those below show performance improvement.

Collectively the results show no consistent pattern of effect between vertical vibration intensity and manual control performance. In the region around  $0.2R_{ms}'g'$  the effects range from nothing at all in the Hornick-Lefritz study to 85% decrement in the Parks-Hickey study.

Primary tasks were similar but the one contrived by Parks and Hickey was much the more difficult. This difficulty factor plus degree of task realism appear to account for some difference in performance between those studies whose results cluster around the abscissa and those which show decrements greater than 10%. In order to test this hypothesis an attempt was made to construct an index of task difficulty based upon the task descriptions given by experimenters in their reports. The attempt, however, proved to be abortive because vital task details were lacking. Consequently a thorough test of the hypothesis was found

impossible but certain comparisons can be made which fortify the impression that task difficulty was a major contributing factor in performance decrement.

Shurmer, for example, like his RAE counterparts used the 'realistic' 5 degree of freedom TSR 2 simulator but unlike the RAE studies he used a task whose control and display were alien in the context of the particular simulator. The task was contrived for the purpose of training and selecting guided missile operators and to add to this his subjects were naive apprentices rather than skilled pilots. His method of scoring was also unusual.

In contrast RAE in their studies used actual aircraft controls and displays added to which in the Concorde study an out-of-the-window view was provided of the runway and horizon. Tasks were more realistic in the Concorde simulation and subjects were skilled pilots. Together these differences seem sufficient to account for the difference between the Shurmer and RAE results shown in Fig. 2.16. The primary task most difficult from the control display dynamics point of view was that contrived by Parks and Hickey. It was also the task which caused most decrement in performance. Other comparisons are possible but these are sufficient to make the point about task difficulty.

The simple comparisons presented above between the primary task difficulty and other realism factors pay no attention to secondary tasks and other factors, in particular human ones, which influence task difficulty. Nevertheless the impression remains that it is task difficulty coupled with task realism which is responsible for performance decrement

and the results of these studies also give the impression that there is a threshold level of these variables below which there is little or no effect and above which there is an effect in proportion to the difficulty which the vibration adds to the task. It is noteworthy in Fig.2.16 that some studies exhibit a linear decrement relationship with vibration intensity which suggests that vibration adds to the difficulty of the manual control task in linear proportion to Rms'g' intensity.

Conclusions concerning ability to perform a primary two dimensional tracking task during vibration (mainly random) are therefore :

(a) That random and near random vibration up to 0.50 Rms'g' is likely to cause performance decrement in the range 0-40% with possible improvements up to 10% and decrements as large as 60-85% if the control task is extremely difficult eg. contains integration time delays of 2secs. or more between control and display movement.

(b) That performance decrement at intensities differing by 0.35 Rms'g' in the range 0-0.5 Rms'g' should be no greater than 25% between extremes of vibration.

#### Secondary Task Performance.

Four vigilance reaction, three instrument and digit reading tests and one compass/heading task were performed in this second group of 7 studies. Vertical vibration up to 0.4 Rms'g' caused no decrement in vigilance and reading performance but a 55% increment in the visual angle of digits was required in order that subjects could read them at 0.94 Rms'g'. At 0.2Rms'g' a 35% decrement in performance was noted in a compass heading task after 4hrs. of exposure. This latter task was similar in its

attentional requirements to the thrust command task examined previously and it is thought that performance decrement was caused similarly by the requirement to carry out fine manual adjustments. But in this case the very difficult primary task associated with the secondary compass heading task must have had some influence upon its performance.

The previous conclusion is fortified ; that time sharing ability is adversely effected when the secondary task involves fine manual adjustment, but the evidence does not support the conclusion concerning vigilance performance. Above 0.15 Rms 'g' subjects who were asked to read instruments began to report difficulties with instrument reading but again their feelings were not reflected in their measured performance. A result which suggests that although subjects were aware that reading was difficult they were in some way able to compensate for the vibration effects - probably by increased effort.

#### Tracking Axes.

With one exception these studies confirm the previous review finding that tracking errors were greatest in the tracking axis corresponding to the vibration axis. Harwood et al. (1968) found otherwise. Their finding was that horizontal errors were greater than vertical tracking errors under vertical vibration. During the climb phase vertical tracking was 28% better than horizontal tracking, an effect which was linked with the simulator attitude which at times reached a nose-up angle of  $23^{\circ}$ . It may be that manual control under these conditions changes, psychologically, control-display compatibility. Alternatively the effect may have resulted from horizontal tracking difficulties caused

The Effect of Non Stationary Random  
Vibration (After Parks & Hickey 1965)

Figure 2.17

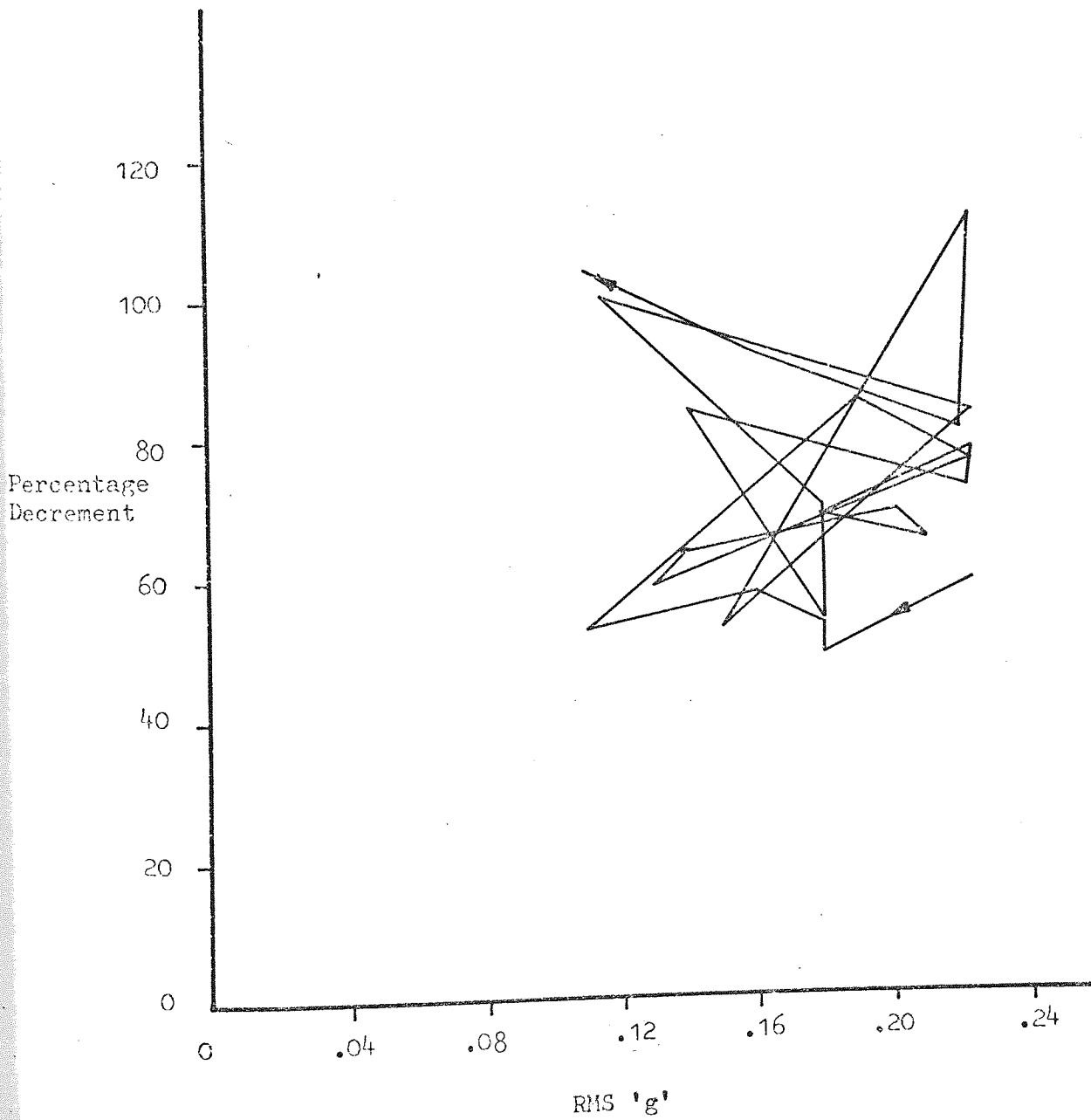

by the simulated vehicle dynamics or by differences in the speed of response caused by differences in simulated pitch and yaw moments of inertia or control characteristics.

#### Duration and Non-Stationarity.

Vibration exposure periods ranged from 1 minute (Shurmer) to 4hrs. (Parks and Hickey). Random vibration in Parks study was non-stationary over the exposure period in the range 0.15-0.275 Rms'g'. Average performance of three subjects at 10 minute intervals is shown in Fig.2.17 Over the 4hr. exposure period no consistent pattern emerges between random vibration intensity and decrement but a clear duration effect is visible both in Fig.2.11 and Fig.2.16. The difference in decrement amounted to no more than 25% between the first and fourth hour of performance. The 25%-4hr. effect found in the Parks and Hickey study probably represents an upperlimit to the duration effect at 0.2Rms'g' due to the high task difficulty involved. The general impression derived from the two reviews is that the fatiguing effect of random vibration over 4-6hr. periods lies in the range 5-15% for primary tasks of 'medium' difficulty. No other duration effects were found amongst the other studies whose exposure periods were 30mins. or less

#### v Task Difficulty.

Conclusions concerning this factor remain unchanged. In those studies where it featured as an independent variable (Weisz et al.(1965), Hornick et al. (1966) increased difficulty was found to cause an increase in primary tracking error. Hornick and Lefritz found a 145% decrement



Vertical Vibration Transmissibility between Seat and Head for Subjects Wearing Lap & Shoulder Harness. The ratios are  $G_{HH} / G_{SS}$ .

Figure 2.18

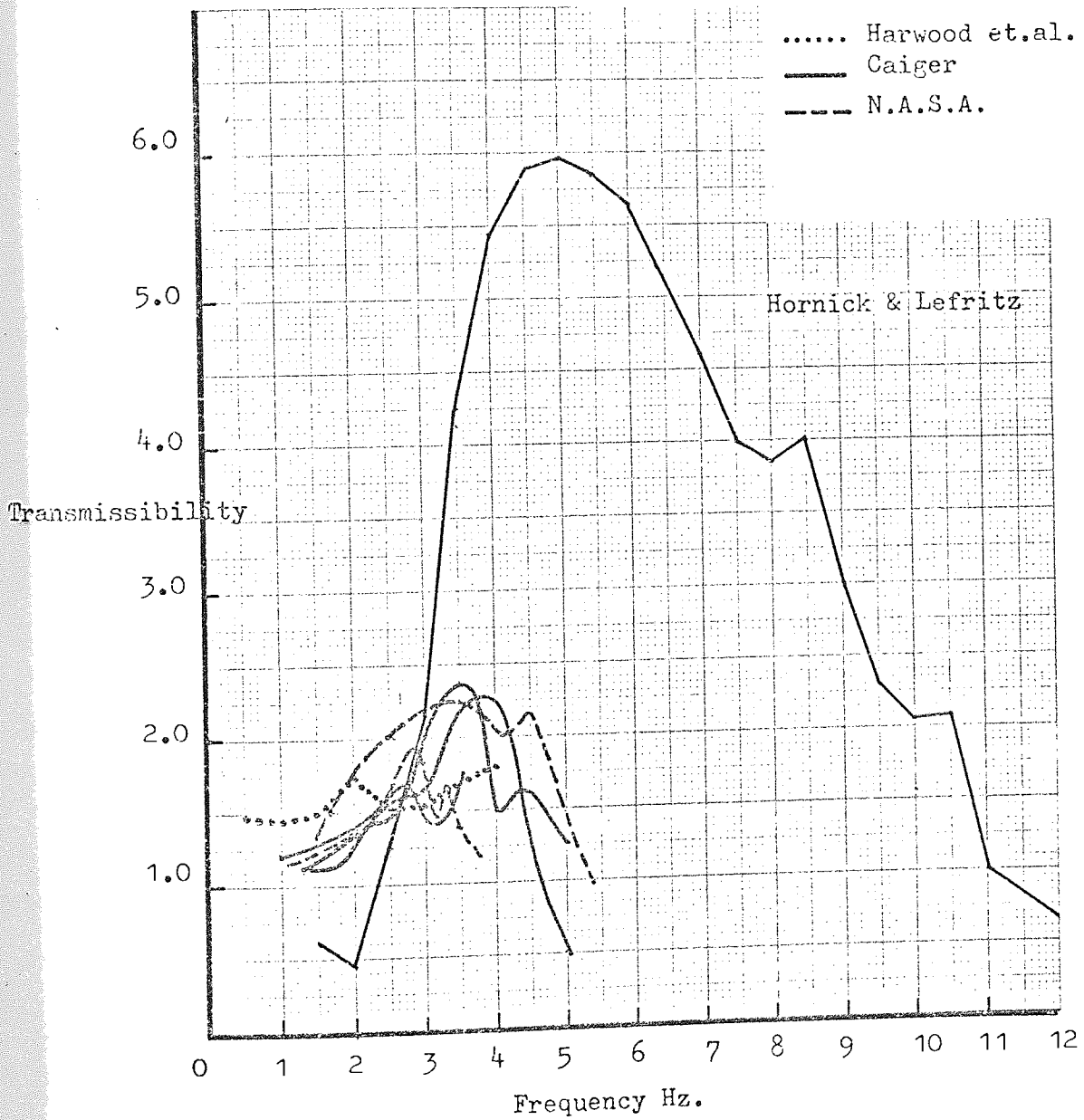

due to differences in task difficulty, an effect which swamps the largest decrement shown in Fig.2.16. Weisz et al. between high and low task difficulty found only a 4% difference at the same vibration level (0.2Rms'g'). Vibration no doubt has an effect upon task work load but no attempts were made to ascertain to what extent. Thus the workload position remains as it was described in the previous review.

#### Transmissibility.

The complex mechanical impedance property of the seated human body means that vibration input at the seat is transmitted through the body to hands and head in a manner which is dependent upon the frequency of input. Seat support and harness restraint also influence the transmission process. Transmissibility is the input/output ratio and this was measured both for vertical and lateral inputs by Harwood et al.. The result is shown in Fig. 2.18. For comparison random vibration transmissibility has been calculated from the input and output spectra given by Hornick and Lefritz, Fig.2.7. The other transmissibility curves in Fig.2.18 were taken from Caiger (1966). They apply to subjects wearing a lap and shoulder harness with random vibration input. By comparison with the rest the transmissibility, as given, by the input and output curves in Fig.2.7 suggest that there may have been calibration errors associated with Hornicks spectrum analysis because of a gain of six at the resonant frequency 5c/s.. The Harwood result is more typical of the random vibration transmissibilities given by Caiger.

### Controls.

At 0.35 Rms'g' Shurmer found that a spring centred sidearm joystick control was 13% better than a force control, Holland found that a centre controller was superior to a similar sidearm controller but Hornick and Lefritz have criticised this result on the grounds that it was a spurious evaluation. Torle (1965), (see Table 2.5) found that performance decrement was reduced 28% by the use of a large sidearm controller and demonstrated the disadvantage of backlash and friction in the control.

### Subject Experience.

Harwood et al. (1968) used a mixture of professional and amateur pilots in their experiment. Their finding was that 'the difference in performance between professional and amateur pilot groups was far less than was originally expected. On this evidence, therefore, it is obviously desirable to use fully representative subjects'. Naive subjects from the point of view of aircraft control tasks were used only by Shurmer. It is thought that his results reflect this fact.

### Arousal.

Often it has been hypothesised that moderate vibration stress has the efficacy to promote 'arousal' in the human organism and inspire it to greater efforts - with improved performance being at the end of the stress - arousal - effort chain. This effect is formulated in the Yerkes-Dodson law and has been written about in general terms by Broadbent (1971)

Vertical Tracking Scores for Vertical,  
Lateral and Combined Vertical & Lateral  
Vibration (After Lovesay 1971)

Figure 2.19

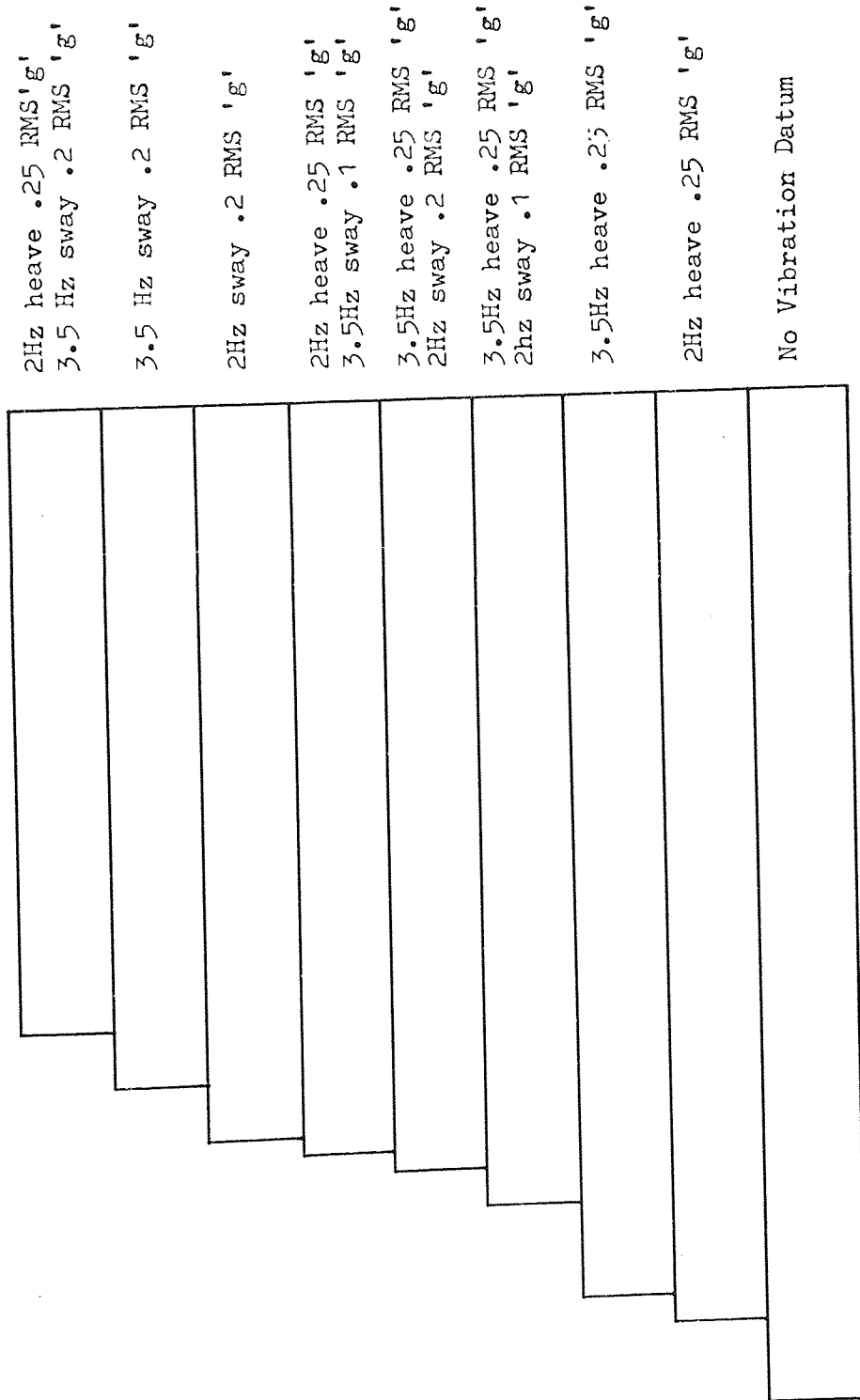

Singleton (1970), Wyon (1970) and Provins (1966). If it is accepted that improvement in performance is evidence of this effect then we have proof of its existence in these studies. In particular Holland found that subjects improved by 4% at 0.12Rms'g' on a secondary task, Harwood and Lovesey in both of their studies found improvement between 9 and 37% and in retrospect what was thought by Whitehead and Fox (1967) to be improvement due to learning was more likely improvement due to 'arousal'. This evidence suggests that under certain conditions effort changes by an amount which is greater in its positive effects on performance than the negative effects of vibration which cause increment in task difficulty. Although the 'arousal' effect itself is probably generalisable the sporadic incidence with which improvements were noted make the terminal improvement effects unpredictable.

#### Multi-Axis Vibration.

Single and combined axis vibration was studied by Harwood and Lovesey (1966), Harwood et al (1968), Shurmer and Silverthorn (1968) and Lovesey (1970). The relevant Figures are 2.13, 2.14, 2.15 and 2.19 respectively Table 2.6 is an extract of all results shown in the figures which are comparable. The performance inequalities shown are between vibration axes and combinations of axes having the same frequency and intensity of vibration. For example in  $V_4 L_2 R_2 < V_4 L_2 < L_2$  the lateral vibration component in the 2 and 3 axis tests was the same as that in the single lateral axis test whose frequency was 2c/s.. The inequality means therefore that lateral vibration on its own caused more performance decrement than when it was in combination with vertical vibration and combined lateral and vertical vibration caused more decrement than

TABLE 2.6 PERFORMANCE INEQUALITIES IN A 2D - COMPENSATORY TRACKING TASK UNDER SINGLE AND MULTI AXIS VIBRATION.

HARWOOD I	HARWOOD II	SHURMER	LOVESEY
SINGLE AXIS $V_2 < L_2$	_____	$R_2 < V_2 < L_2$ $V_4 < L_4 < R_4$	$V_{3.5} < L_{3.5}$ $V_2 < L_2$
TWO AXIS $V_2 L_2 < V_2 < L_2$	$V < VL$ Runway $V < VL$ Climb $V < VL$ Cruise	$V_2 < R_4 < V_2 R_4$ $V_4 < R_2 < V_4 R_2$ $V_4 L_2 < L_2 < V_4$ $L_4 < V_2 < V_2 L_4$ $V_4 < V_4 L_2 = L_2$	$V_2 < L_{3.5} < V_2 L_{3.5}$ $V_{3.5} < L_2 < V_{3.5} L_2$
THREE AXIS _____	_____	$V_4 L_2 R_2 < V_4 L_2 < L_2$ $V_4 L_2 R_2 < R_2 < V_4 E_2$ $V_4 < V_4 L_2 R_2$ $V_4 L_2 < V_4 L_2 R_2 < R_2$	High energy _____ Low energy

Note: V = Vertical vibration

L = Lateral vibration

R = Roll vibration

Suffix numbers represent the frequency of vibration

when the VL combination was triple combined with roll vibration also at the same frequency, 2c/s..

In five out of five such comparable cases lateral vibration caused an average 22% more decrement than vertical vibration; combined vertical and lateral caused an average 21% more decrement than vertical in 7 out of 9 cases; combined vertical and lateral more than lateral in 3 out of six cases with differences not exceeding 10% in all six; and with the triple combination VLR causing decrements not exceeding 5% in 3 out of 4 cases. The largest differences are therefore between vertical and lateral and between vertical and combined vertical/lateral vibration. By ranking the vibration conditions used by Shurmer, Fig.2.15 according to the sum of Rms 'g' level(s) and roll amplitude a correlation was found between the sum and performance decrement suggesting that the latter is dependent upon total energy in the combined vibration situation. Combined vertical/lateral vibration in unquantified expressions by subjects was found to effect visual performance to the point where it was stated to be impossible to read ASI digits and very difficult to read a flight director. By comparison with vertical vibration such combined vibration was regarded by subjects as most uncomfortable, the discomfort resulting mainly from lateral vibration.

#### The Significance of Vibration Effects.

Practical as distinct from statistical significance requires that the evidence on speed and accuracy of man as a controller be translated into and then evaluated in terms of consequences specific to a particular situation. Modern probabilistic system design requires that the occurrence

of critical conditions be kept within acceptable probability margins. To achieve this it may mean that functions which could be performed by a human operator may have to be automated in order to achieve adequate speed, accuracy, consistency and reliability. Alternatively ways and means of reducing human error may have to be considered if it is essential that control functions be performed by a human operator. Much of the evidence presented in this review was obtained by system design teams because problems were anticipated concerning human performance. It is not known whether or what kinds of design decision were based upon the findings but one suspects that, for example, in the case of LAHS aircraft steps will have been taken to automate the terrain following function because vibration at levels between 0.3-0.4 Rms 'g' were found to cause human operators to 'crash the simulator'. The Concorde simulator indicated that vertical and particularly combined vertical and lateral vibration caused experienced pilots to exceed runway margins and stall during climb. The results would suggest that action may have been taken either to automate the control function, to find ways and means of mitigating the vibration or to draw attention to the phenomenon so that a proper assessment may have been planned with the real aircraft.

The importance of the evidence on the effects of vibration on human performance lies not in the percentage decrement figures but in the action which they engender as a result of the uncertainty which they convey to the system designer. It is his job to build the uncertainty into the consideration of system probabilities and to decide upon the design measures required to countermeasure the likely decrements in human performance.



Most research workers whose work is reported in this review went to the trouble to test their results statistically and to design their experiments so that proper account could be taken of independent variables and other influential factors such as learning and asymmetric transfer effects which occur due to the order of testing vibration conditions. Changes in performance between vibration and no vibration conditions which were found to be statistically significant have been indicated as such in Fig. 2.16.

### 2.3.10

#### Random v Sinusoidal Vibration Effects.

It has long been thought that these two distinct patterns of vibration would have distinct effects upon the performance of man as a controller. The reasons for thinking that this may be so stem from the distinct sensations that they produce and from the mechanical resonance property of the human body. The frequency of major body resonance between seat and head lies in the range 3-5c/s. as shown in Fig.2.18. Within this frequency range and dependent upon support and restraint, vertical vibration input at the seat interface is amplified at the head by a factor between 1.5 and 3.5. The amplified motion of the head, however, takes time to build up because of an inherent time delay at this frequency of about 0.05sec.. 0.05seconds after application of vibration at 5c/s. the head will begin to move. 0.1secs. after the start of the sinusoidal vibration cycle it will reach the input peak of the sinusoidal cycle. 3 or 4 cycles later dependent upon the damping of the body motion the head motion will have built up to its full amplification relative to seat movement. The full resonant effect therefore takes between 0.6-0.8 secs. to develop ie. 3-4 full cycles of the sinusoidal motion. When

TABLE 2.7 - SINUSOIDAL V RANDOM STUDIES

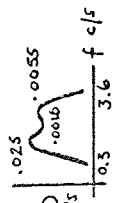
Author	Vibration	Exp. Cond.	Tasks	Findings
Parks D. L. (1961)	Sinusoidal 0.75, 2.5Hz Random amp. 0.75, 2.5Hz Random  Equated for amp. power, subjective quality Rms 'g', mean amplitude, Rms 'g' levels 0.083, 0.13, 0.26, 0.33.	Complex exptl. design 10 subjects.	Primary 2D-comp. tracking separate colour coded vert. & horiz. displays. Secondary 1. anticipation of display position 2. response time to warning light.	Primary tasks, horiz tracking 25% better than vert. No diff. (P < .05) between vib. types Sine better at 3 lower levels, worst at 0.33g., 2.5Hz. secondary tasks no effect. Rms. only parameter related to perf.
Chaney Parks D. L. (1964)	as above	Tracking task with and without time delay between control-display.	2-D Comp. tracking as above. One condition with control-display lagged by 2 secs.	No different (P < .05) between vibration types significant diff. at 0.25Hz. 0.24 Rms 'g' between random and sinusoidal. Sine vibration more.
Weisz A. Z. Goddard C. J. & Allen R. W. (1965)	as above	as above	as above	No difference at equivalent Rms 'g'

vibration is random in amplitude and frequency there is no guarantee that such frequency components will persist for such periods. Consequently with random vibration the resonant amplification factor forms a statistical distribution whose lower limit is 1.0 and whose upper limit is somewhere in the region 3.5-4.0. Between these extremes the amplification will follow the shape of the Rayleigh distribution with peak probabilities equal to the standard deviation. This distribution as far as is known has never been measured but its existence in theory means that random vibration whose frequency spectrum spans body resonance should cause less head and shoulder movement and therefore less interference with manual control than the same energy applied sinusoidally. A number of tests have been made in order to evaluate this possibility;

Parks (1961), to test for distinct performance effects, used 10 subjects in a complex experiment where subjects performed a primary two dimensional tracking task and two secondary tasks. Performance was measured under random sinusoidal and amplitude modulated sinusoidal vibration equated on the basis of amplitude power, subjective quality, Rms 'g' and mean amplitude. Rms 'g' levels used were 0.083, 0.13, 0.26 and 0.33. Sinusoidal frequencies were 0.75 and 2.5Hz. and these were the dominant frequencies in the random vibration spectrum whose profile is shown in Table 2.7. Differences in performance expressed as inequalities were as follows :

2.5 Hz.	0.33 g.	Random < Amp. Mod. < Sine
2.5 Hz.	0.083g.	Sine < Amp. Mod. = Random
0.75Hz.	0.26 g.	Sine < Amp. Mod. < $\frac{1}{2}$ Random
0.75Hz.	0.13 g.	Sine < Amp. Mod. = Random

Horizontal & Vertical Tracking Efficiency  
during 5Hz Sinusoidal, 5Hz Random Amplitude  
& 4 - 12Hz Random Amplitude & Frequency  
( After Weisz, Goddard & Allen 1965)

Figure 2.20

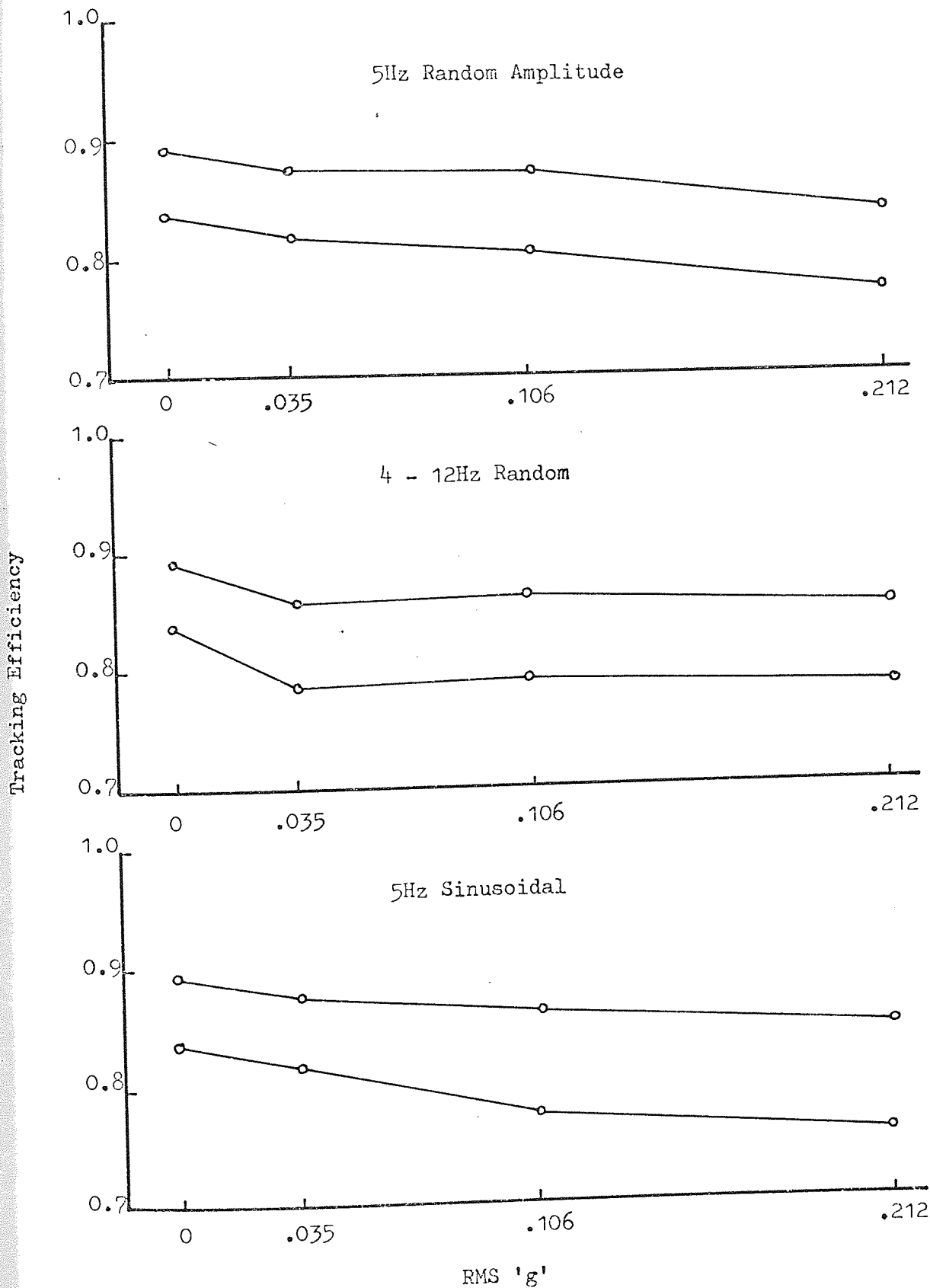

Statistically Parks found no difference between vibration types ( $P < .05$ ) but performance was worst under sinusoidal vibration at 2.5Hz. and 0.33 Rms'g'. Rms'g' was found to be the only vibration parameter related to performance. There were no vibration effects on secondary task performance.

Chaney and Parks (1964) in a repeat study used the same primary and secondary tasks but added a condition where control and display movement in the primary task were lagged by 2secs. On this occasion a significant performance difference ( $P < .05$ ) was found between random vibration and sinusoidal vibration but only at 2.5Hz., 0.24Rms'g'. No other effects were noted.

Weisz, Goddard and Allen (1965) in an experiment already noted compared 5Hz. amplitude modulated and 4-12Hz. random vibration at 0.035, 0.106, 0.177 and 0.212 Rms'g'. Fig. 2.20 shows that primary task performance was effected by all three types of vibration. Although non significant the results show that random vibration was more effective than the other types at the lower vibration level, 0.035Rms'g' but less so at 0.212Rms'g'. This result confirms Parks finding.

Thus it would appear, on the grounds of measured performance, that random, sinusoidal and amplitude modulated vibration equated in terms of Rms'g' are no different in their effect on manual control performance. There is some evidence that random vibration has more effect than sinusoidal at levels below 0.13Rms'g' and vice versa at 0.212Rms'g' and higher levels. At the higher levels the theory expounded above is thought to provide sufficient explanation for the greater sinusoidal effect. The greater random effect at lower levels may result from severe

A Summary of the Effects of Sinusoidal Vibration on the Performance of Primary Control and Tracking Tasks.

Figure 2.21

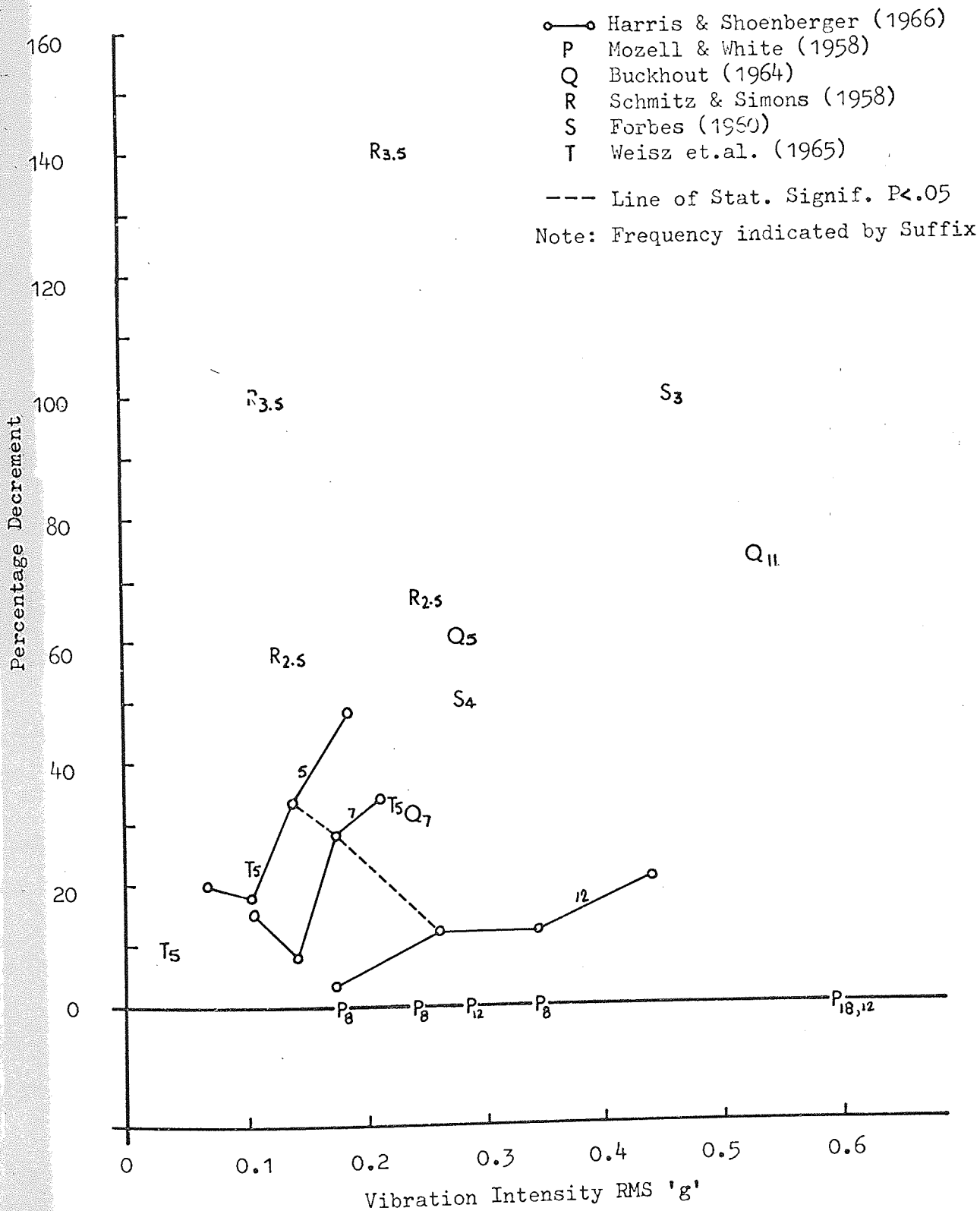

jolts which occur from time to time with this type of vibration.

These studies suggest that it may be valid to pool performance data obtained under sinusoidal vibration conditions with random vibration results - a conclusion which justifies the pooling which has taken place so far in this review. In view of this evidence it has been decided to present a brief summary of the findings which have resulted from the use of sinusoidal vibration.

### 2.3.11. Sinusoidal Studies.

For the purpose of comparison a number of sinusoidal vibration/tracking task studies deserve mention. For the most part studies of this kind have featured abstract tasks, not related to any manual control problem, which were chosen by authors whose purpose was to discover something fundamental about the interaction between vibration and psychomotor performance. For this reason most sinusoidal studies cannot be compared with those previously reviewed and in addition it is sad that most of this 'fundamental' work failed to take advantage of developments in the 1950's and early 1960's in Information Theory, Crossman (1960). Had use been made of Information Theory authors would have been able to describe the difficulty of their tasks and express psychomotor performance in comparable units. As it is, most tasks that have been described fail to convey details which make it possible to judge difficulty and therefore comparability but six out of 32 consulted have been chosen and their results are shown in Fig.2.21.

Harris and Shoenberger (1966) aimed their study at discovering the levels and frequencies of vibration at which significant performance decrements occur. Test frequencies of 5, 7 and 12 Hz. were chosen corresponding to the frequency of major body resonance, heart resonance and secondary body resonance respectively. At these frequencies subjects performed a 2D comp. tracking task, used a sidearm control and were restrained by a full harness. Under these conditions it was found that significant decrement ( $P < 0.01$ ) at 5 Hz. occurred at  $0.14 \text{Rms}'g'$   $0.175 \text{Rms}'g'$  at 7 Hz. and  $0.26 \text{Rms}'g'$  at 12 Hz. The significance boundary is shown in Fig. 2.21. Judging by the care taken in the design of this experiment the results appear to offer a standard with which to judge the statistical significance of other sinusoidal studies. From the task description given by Harris and Shoenberger their task appears to resemble the primary task used by Holland and Weisz et al. with whose results they are in good agreement. The other results in Fig. 2.21 are those of Mozell and White (1958), Buckhout (1964), Schmitz and Simons (1959), Forbes (1960) and Weisz et al. (1965). The task in the Mozell and White study was the easiest in the group and this is reflected in the fact that they found no decrement in performance at any frequency or intensity. Decrements of 100% and 140% were found by Schmitz and Simons but nothing in their report suggests that their task was more difficult than that used by Harwood (1968) who noted improvements at the same frequency and intensity. On the contrary it would appear that the Harwood task was more difficult. The difference between these results emphasise the point made earlier 'that it is not possible to compare what was, in the Schmitz and Simons case, an abstract task with performance of something more realistic. On the positive side the sinusoidal studies which are comparable with those previously examined



support the finding that random and sinusoidal vibration are no different in their effects. As a group the results suggest a frequency sensitivity relationship of the type found by Shurmer (1967) and Allen (1971) in their reviews of sinusoidal vibration effects on tracking task performance, see Fig.2.22 and Fig.2.23.

# Summary of Sinusoidal Vibration effects on Vertical Compensatory Tracking (After Shurmer 1967)

Figure 2.22

PEAK ACCELERATION  
LEVEL x G

4G ←  
1/200

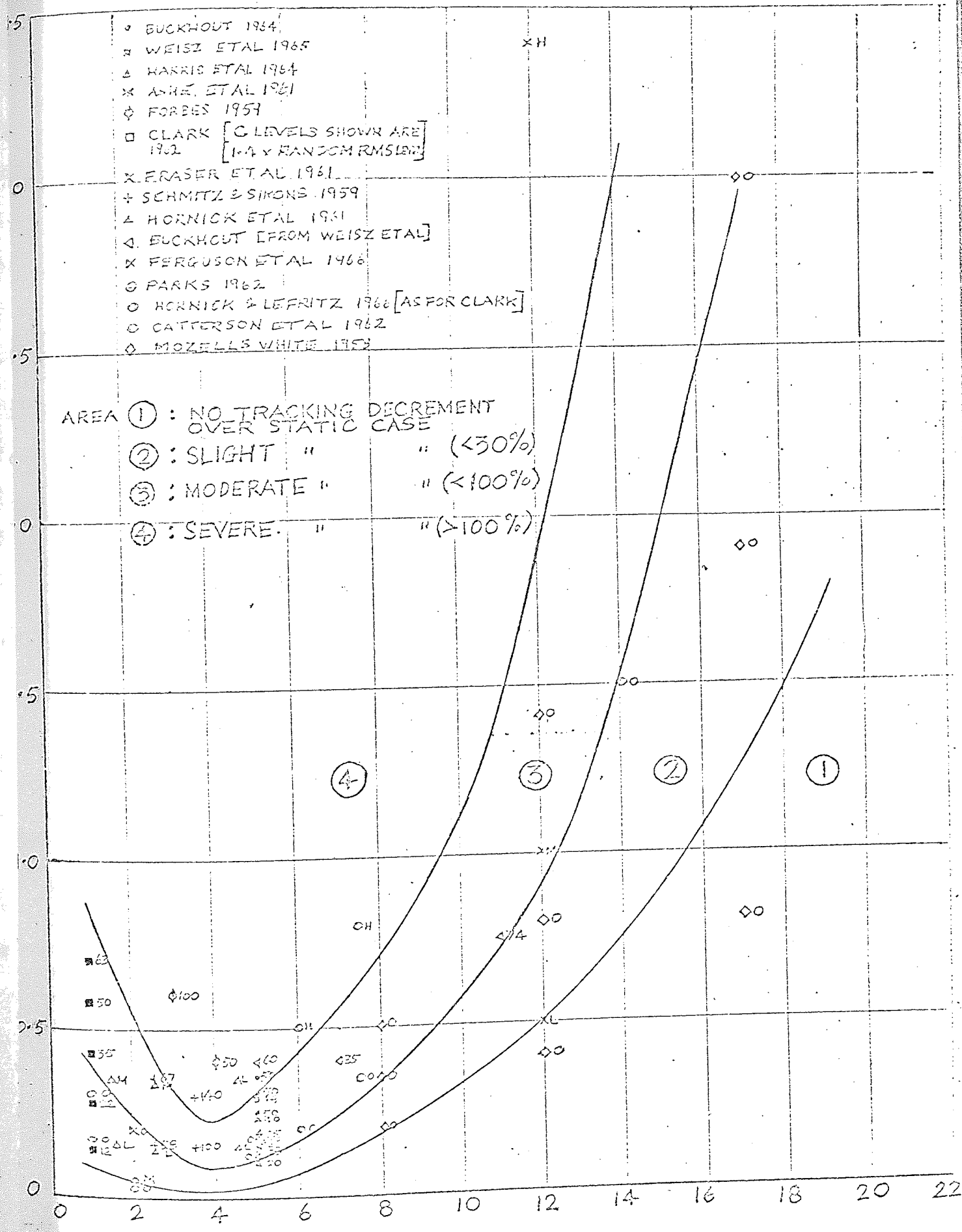

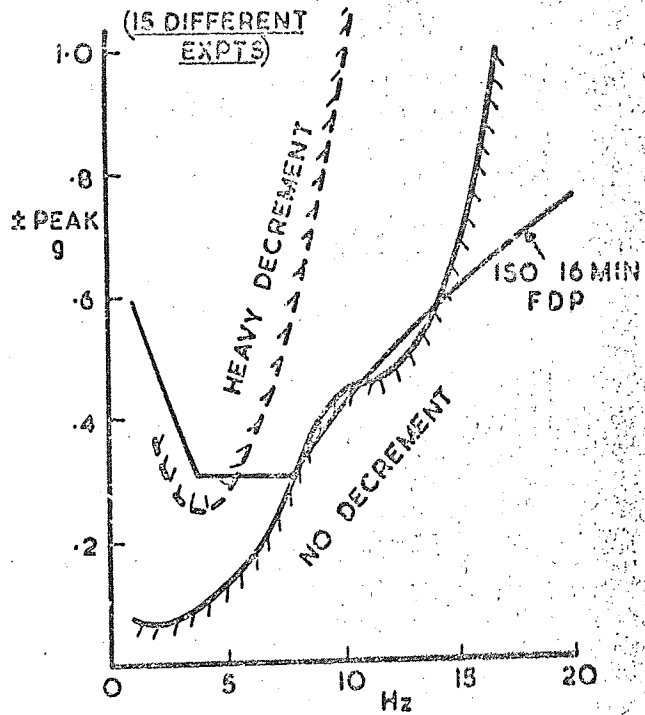

FIG.6 TRACKING PERFORMANCE UNDER  
VERTICAL SINUSOIDAL VIBRATION

#### 2.4.0. DEVELOPMENT OF AN ADAPTIVE TASK.

The experimental studies reported in this thesis began with the development of an adaptive manual control task. The manual control task was chosen to satisfy a number of requirements. It had to have a good theoretical basis and be amenable to control system and operator dynamic analysis.

It had to be a task of known or measurable difficulty and mechanisable as an adaptive task with difficulty variable from easy to impossible. The final requirement was that it fit into a small twenty amplifier analog computer. To satisfy these requirements the task chosen was the "critical" tracking task developed by Jex, M<sup>C</sup>Donnell and Phatak (1966) for manual control research. It was implemented as an adaptive one dimensional compensatory tracking task and mechanised on a PACE TR10 Analog Computer.

##### 2.4.1. Task Theory.

Jex et al. have likened their "critical" task to the control of a forward facing caster of zero mass. Balancing an inverted pendulum is a better analogy because everyone knows what happens to the difficulty of the balancing task when the length of the pendulum rod is reduced or extended. Jex et al. in their implementation arranged it so that the task began with a very long pendulum which reduced rapidly at first and then at a slow constant rate until the length of the pendulum was so short that control was no longer possible and the pendulum fell over; thus terminating the trial. In fact trials were terminated at the instant

in time when the state of the controlled element, displayed on an oscilloscope, exceeded the margins of the scope face. At this instant the degree of instability (length of pendulum) was calculated and this was used as the measure of manual control capability. For the purpose of this study the task was modified. The ramp instability feature was replaced with a facility whereby it was possible to vary instability up and down continuously according to a system of logic which connected instability to a tracking performance measure. Instability (task difficulty) was thus increased when performance rose and was decreased when it fell. The rates of increase and decrease were optimised during preliminary trials. To retain a certain degree of realism care was taken when choosing the rate of decrease to leave it so that it was possible for the 'pendulum' to fall over.

#### 2.4.2. Controlled Element Dynamics.

Subjects used a displacement type joystick to control the position of a line on an oscilloscope. The position of the line relative to centre zero on the scope represented the positional state of the controlled element. The displacement of the control D and position of the line X were equated as follows :

$$X = \frac{\overset{\circ}{X}}{\lambda} - DK_c$$

where  $\overset{\circ}{X}$  is the velocity of the line,  $K_c$  the gain of the control and  $\lambda$  the element loop gain factor or instability - (task difficulty) variable.

The control - display relationship was therefore :

$$\frac{X}{D} = \frac{K_c \lambda}{s - \lambda} \quad \text{where} \quad S_x = \frac{dx}{dt} = \overset{\circ}{X}$$

The figure below shows the controlled element in the functional form of an analog computer program

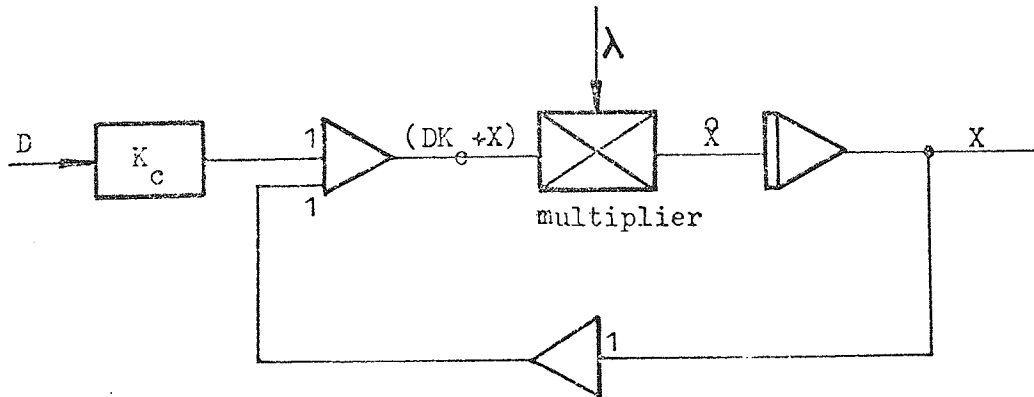

### 2.4.3. Task Difficulty.

The difficulty of the first order instability task shown above is proportional to  $\lambda$  (a variable whose value remember was derived from the performance score).  $\lambda$  has the effect of varying the loop gain of the controlled element the state of which determines its speed of response or Time Constant. The reciprocal of this time constant is the natural radian frequency,  $\omega$ , of the element and it was this measure that Jex et al. used to describe instability and therefore performance of subjects.

The higher the loop gain the faster the element responds and oscillates. Loss of control, simply stated, happens because the human operator falls behind in his response because of inherent time delays. These time delays extensive research has shown, are made up of transport delays, central nervous system latencies and neuromuscular lags, but are counteracted to some extent by anticipation and high frequency lead equalisation. The net result is an effective time delay  $\tau_e$  which varies randomly with

Systems Analysis of the JEX Critical Tracking Task, Performance Results and Operator Gain during performance (After Jex 1966)

Figure 2.24

Systems Analysis Of Human Operator Control of a First Order Divergent Controlled Element

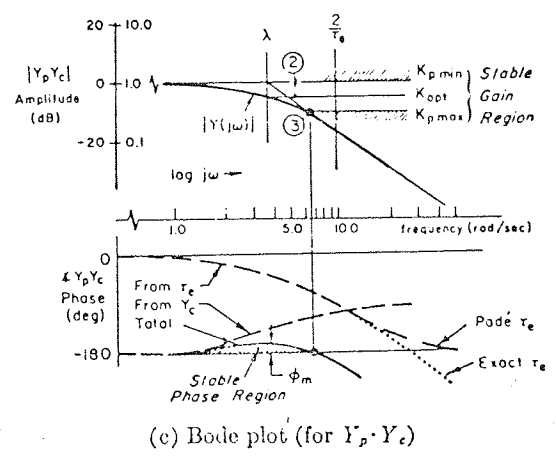
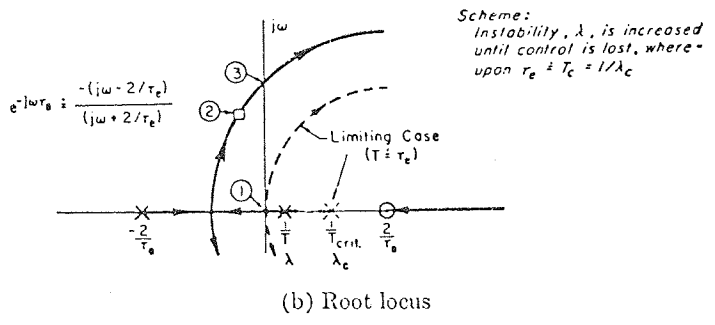

Autopaced Critical Task Scores.

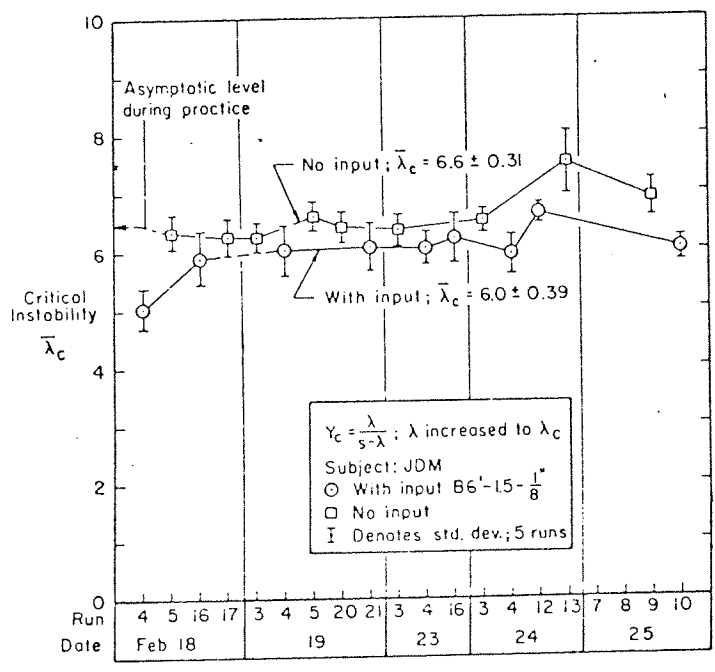

Human Operator Open Loop Describing Function

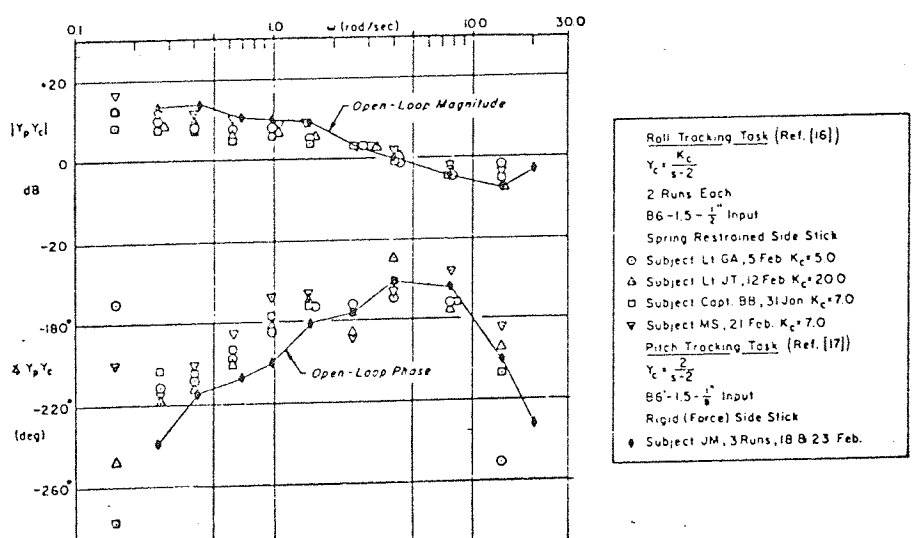

time. When the controlled element time constant,  $T$ , reduces to a value  $T_c$  equal to this effective time delay  $\tau_e$  control is no longer possible. By measuring  $T_c$  the "critical" tracking task is therefore measuring the time delays inherent in the human operator. This is the measure of skill. Jex chose to express it as the reciprocal radian frequency,  $\omega_c = 1/T_c$  so that the higher the value of the  $\omega$  the greater the skill of the operator.

The units of task difficulty in this study are therefore radians per second which makes the results of the adaptive task comparable with those obtained by Jex. The adaptive variable was therefore  $\lambda$ .

#### 2.4.4. Dynamic Analysis and the Human Operator Describing Function.

Conventional Servo Analysis-Root Locus and Bode plots for the controlled element were given by Jex et al. in their vigorous analysis of the control problem. These are shown in Fig.2.24.(a,b). They show first the gain and phase stability margins that exist and how the control behaviour of the human operator is constrained by the requirements of the task. As the instability is increased it is shown in 2.24.(b) that the operators own gain, if he is to be effective in maintaining control, must remain within an ever narrowing gain bandwidth. At 8.5 radians per second control is theoretically impossible but this is likely to be lowered in practice by low frequency lags in the human operator to a value of 6.5-7.5 radians per second. Tests were carried out by Jex et al. with one skilled subject over a period of 7 days resulted in an average critical instability (task difficulty) of  $6.6 \pm .031$  radians per sec.. See Fig.2.24.(c).



The Experimental Set Up.

Figure 2.25

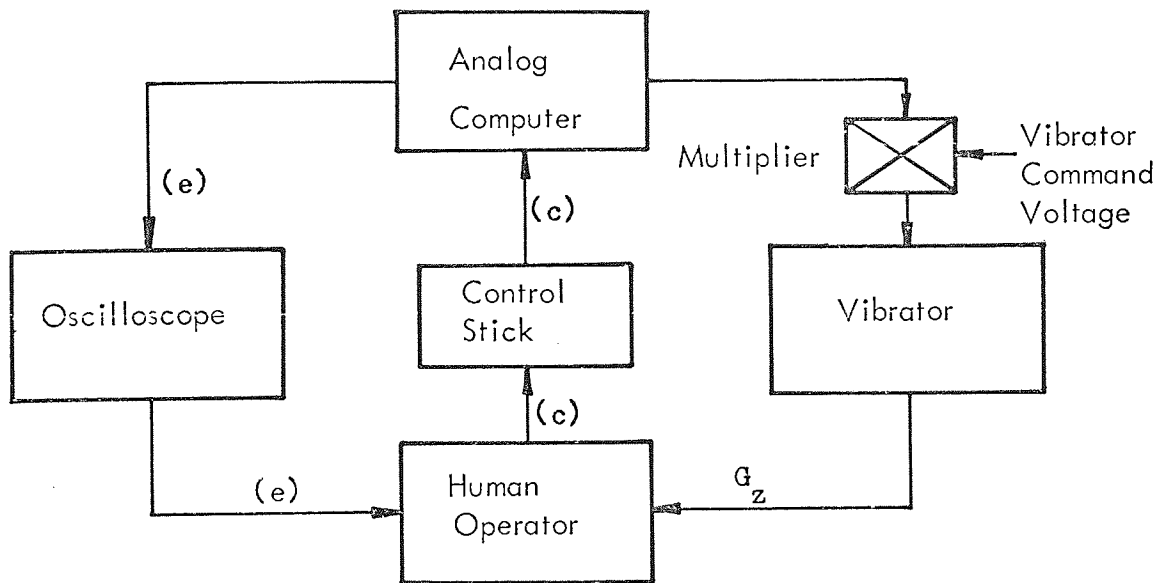

Block Diagram Representation of the Human Operator in the Adaptive Control/ Adaptive Vibration Configuration

Figure 2.26

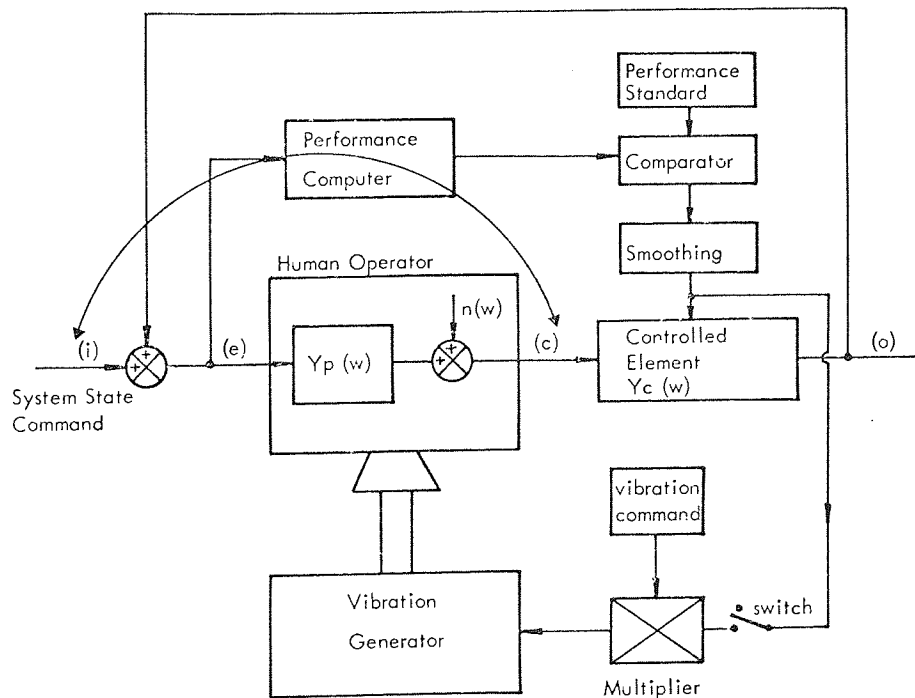

Two sets of data are shown plotted in 2.24.(c) the first marked 'no input' was performed without command. The input results refer to the task performed with system state command. This was the configuration used in this study: it is shown in Fig. 2.26.

Given a random input it is possible to compute what has come to be known as the human operator describing function  $Y_p$  (M<sup>c</sup>Ruer 1969). This function is the frequency response characteristic of the human operator. It is the ratio of the cross spectral densities between input and control actions and between input and the error signal seen by the human operator. The input auto spectrum divided by the cross spectrum between input and error is the combined man-machine 'open-loop' describing function  $Y_p Y_c$ . The derivation of these describing functions is given in Appendix D and a schematic diagram of the man-machine relationships in Fig.2.26.. Both  $Y_p$  and  $Y_p Y_c$  have been measured by Jex et al.: 2.24(d) is an example of  $Y_p Y_c$ . It depicts control behaviour at a constant low level of instability  $\lambda = 2\text{rads/sec}$ . The gain spectrum at the top in (d) shows that operators were effective in their control actions up to a frequency of 3.5c/s.. This effective bandwidth is the frequency at which the gain curve crosses unity gain hence it is termed the 'crossover frequency'. At unity gain the operator input is as large as his output which means he is reducing no error. The reciprocal of 'crossover frequency' is equivalent to the operators effective time delay  $\tau_e$ . In the present study  $Y_p$  and  $Y_p Y_c$  were measured off-line by analysis of magnetic tape recordings made of the input (i), error (e) and control actions (c).

Tracking Task Signal Characteristics.

Figure 2.27

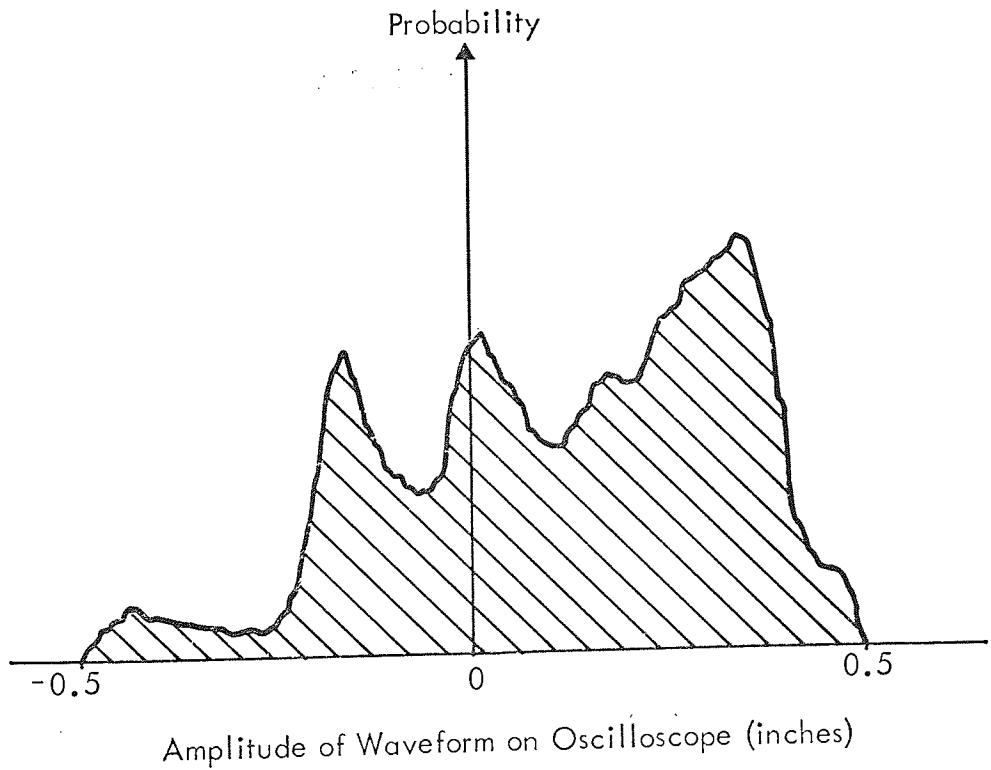
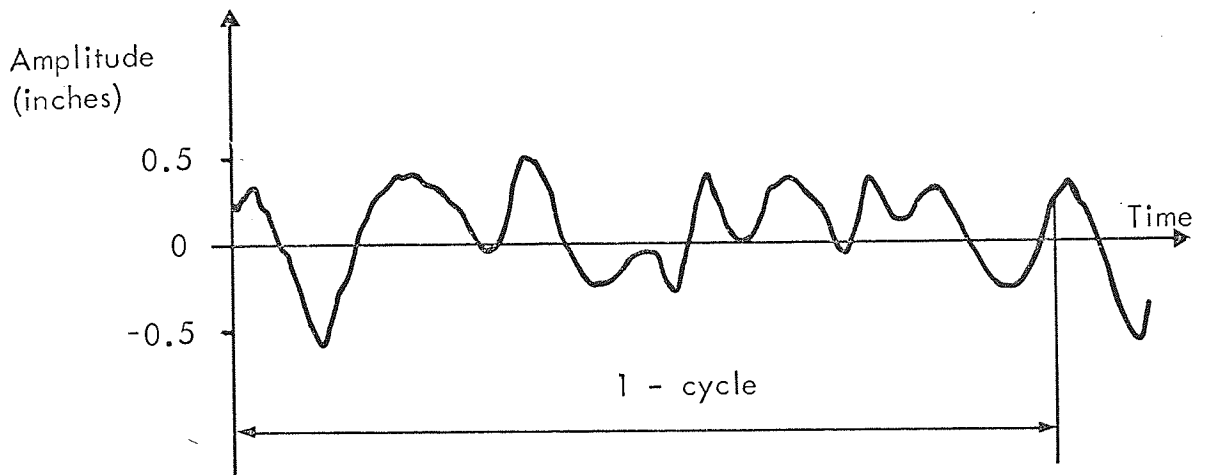

# FOURIER/HANNING TRANSFORM

G. D. WHITEHEAD

Figure 2.20

Autocorrelation  $R_i$  & Auto

Power Spectrum  $G_i$  of the  
input signal

$R(0) = 0.273553E 06$

$R(INF) = 0.263352E 06$

AUTOCORRELATION COEFFICIENT

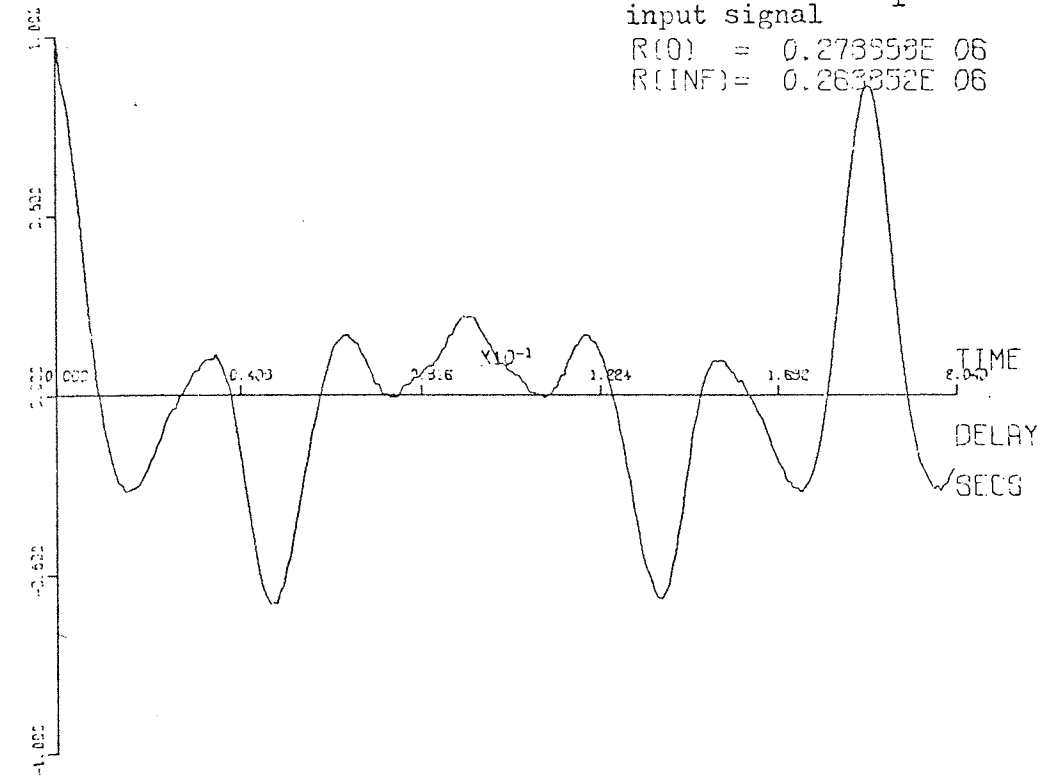

POWER SPECTRAL DENSITY

CM. CM/RAD/SEC

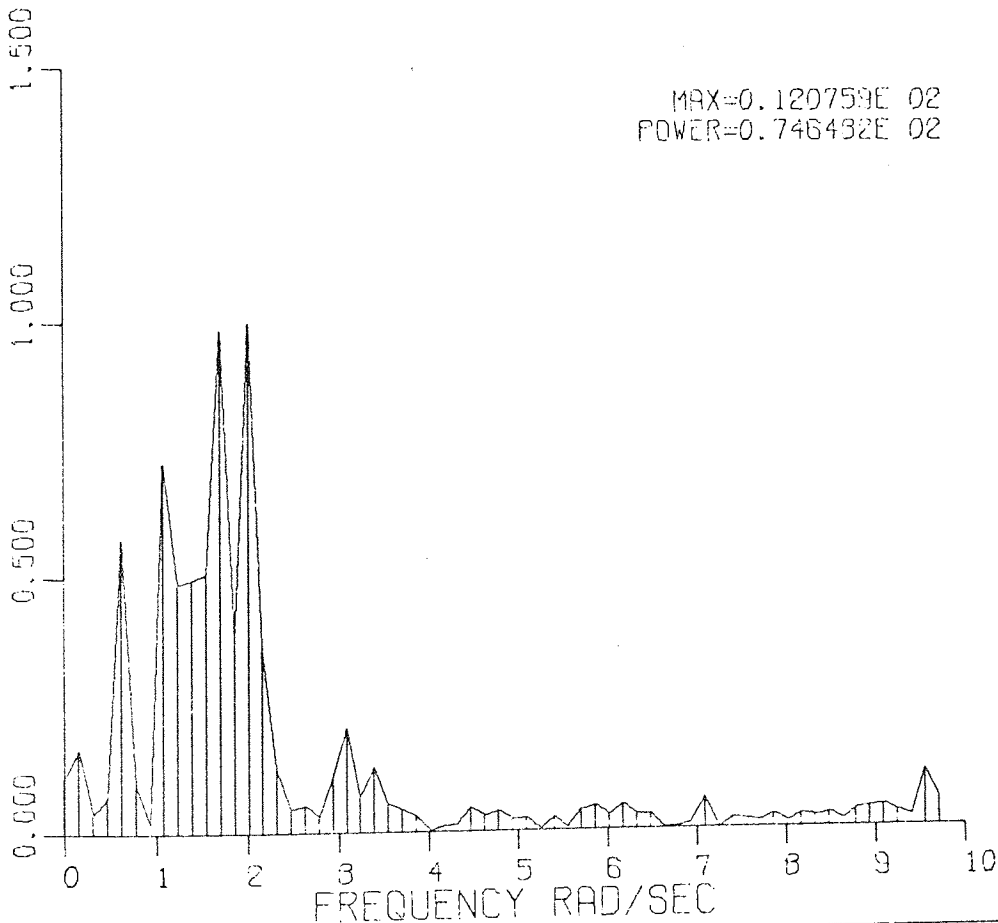

MAX=0.120759E 02  
POWER=0.746432E 02

CYCLES/SECOND

FIGURE 2.29  
Zero Crossing Analysis.

Task Input Signal

Note vertical scale not cal.

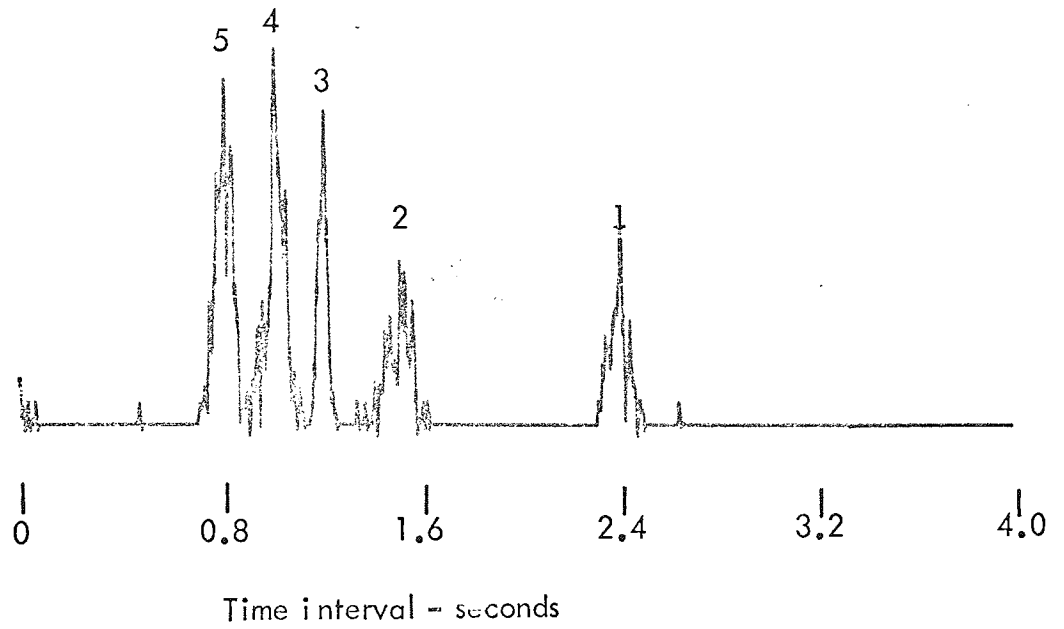

Frequency Components

- 1. 0.208 c/s
- 2. 0.338 c/s
- 3. 0.422 c/s
- 4. 0.512 c/s
- 5. 0.658 c/s

#### 2.4.5. Command Input

Seven sine waves were summed to provide a random looking task input signal. One cycle of the waveform as seen by the operator is shown in Fig.2.27. Positive and negative peak values of the waveform were arranged to give  $\pm 0.5$ in. line displacement at the scope face. The amount of time spent by the waveform at displacement intervals between  $\pm 0.5$ " is shown by the Amplitude Probability Distribution in the figure below. Note that the input signal spends most of its time in one of three places and that  $\frac{2}{3}$  of its time is spent to the right of the display centre line. The line movement spectrum and Autocorrelogram associated with the waveform is shown in Fig.2.28. In theory the seven non harmonically related sine wave components of the waveform, should appear at 0.2,0.55,1.0,1.7,2.1, 3.2 and 6.3 rads/sec.. The highest frequency 6.3rads/sec., which does not appear in the measured spectrum, was intended to provide a command movement frequency near to the critical instability value of 6.5-7.5rad/sec. Apart from this component the other six agree quite well with what was intended.

As an example of zero crossing analysis a time interval histogram is shown in Fig.2.29 with the zero value positioned as shown in Fig.2.27. Five dominant time intervals emerge whose corresponding radian frequencies are 1.3,2.12,2.65,3.22 and 4.08. These frequencies bear little relationship to the component sine waves in the waveform but they are of the right order of magnitude.

The command input signal was provided by a rotating disc type waveform generator kindly loaned by the Human Engineering Division, RAE, Farnborough.

2.4.6. The Performance Measure.

Mean modulus of error was the performance measure. This being the conventional compensating tracking score. The mean value was obtained by low pass filtering with a 2 second time constant.

2.4.7. The Performance Standard.

A constant performance voltage  $e_L$  served as the performance standard. The value of the voltage was optimised during development trials.

2.4.8. The Adaptive Logic.

Changes in performance  $|\bar{e}|$  were accompanied by changes in task difficulty  $\lambda$  according to the law :

$$\lambda = k \int_0^T (e_L - |\bar{e}|) dt + \lambda_{INITIAL}$$

where  $0 < \lambda < 10$  radians per second

T = Time into the Trial.

and  $\lambda_{initial} = 0$ .

so that for values of  $|\bar{e}| < e_L$  task difficulty  $\lambda$  would rise at a rate proportional to the gain factor K and fall at the same rate for values of  $|\bar{e}| > e_L$  .

The adaptive variable record (vaguely visible on the XY plotter in Photo's 4 and 8) was averaged by eye. This value was then communicated to the subject via earphones as a score out of ten. At the same time



Photograph 1.

Display, control and seat accelerometer.



the subject was told whether the current score was better or worse than the previous score which had been noted by the experimenter.

In its fully developed form feedback was inherent in the adaptive task. It was possible to 'sense' the degree of instability of the controlled element. Occasionally control was lost which informed subjects that they had exceeded their personal ability at that moment.

#### 2.4.9. Display

The control task was displayed on a 3" wide oscilloscope, 42" distant from the eye, subtending an included angle of 4 degrees six minutes (app.) The appearance and disposition of the display relative to the observer are apparent in the photographs. The vertical line representing the state of the controlled element moved left/right compatible with movement of the control. It is important to note that the display was mounted on the floor so that relative to the observer whose maximum amplitude was  $\pm 3''$  an 8 degree change in vertical viewing angle was possible.

#### 2.4.10. Control.

The control was an unsprung and undamped joystick mounted in a lightweight box. The box was not mounted in any way. It was left to the subject to support it in whatever manner was thought most appropriate. The technique adopted by the subject in the Photograph 7 was fairly typical but subjects were not allowed to grip the box between their legs. The idea behind the unsupported box and arm was to produce a 'worst' control condition.  $K_c$ , the control-display gain was fixed at 10. The

Results of Adaptive Task Parameter Studies.

Figure 2.30

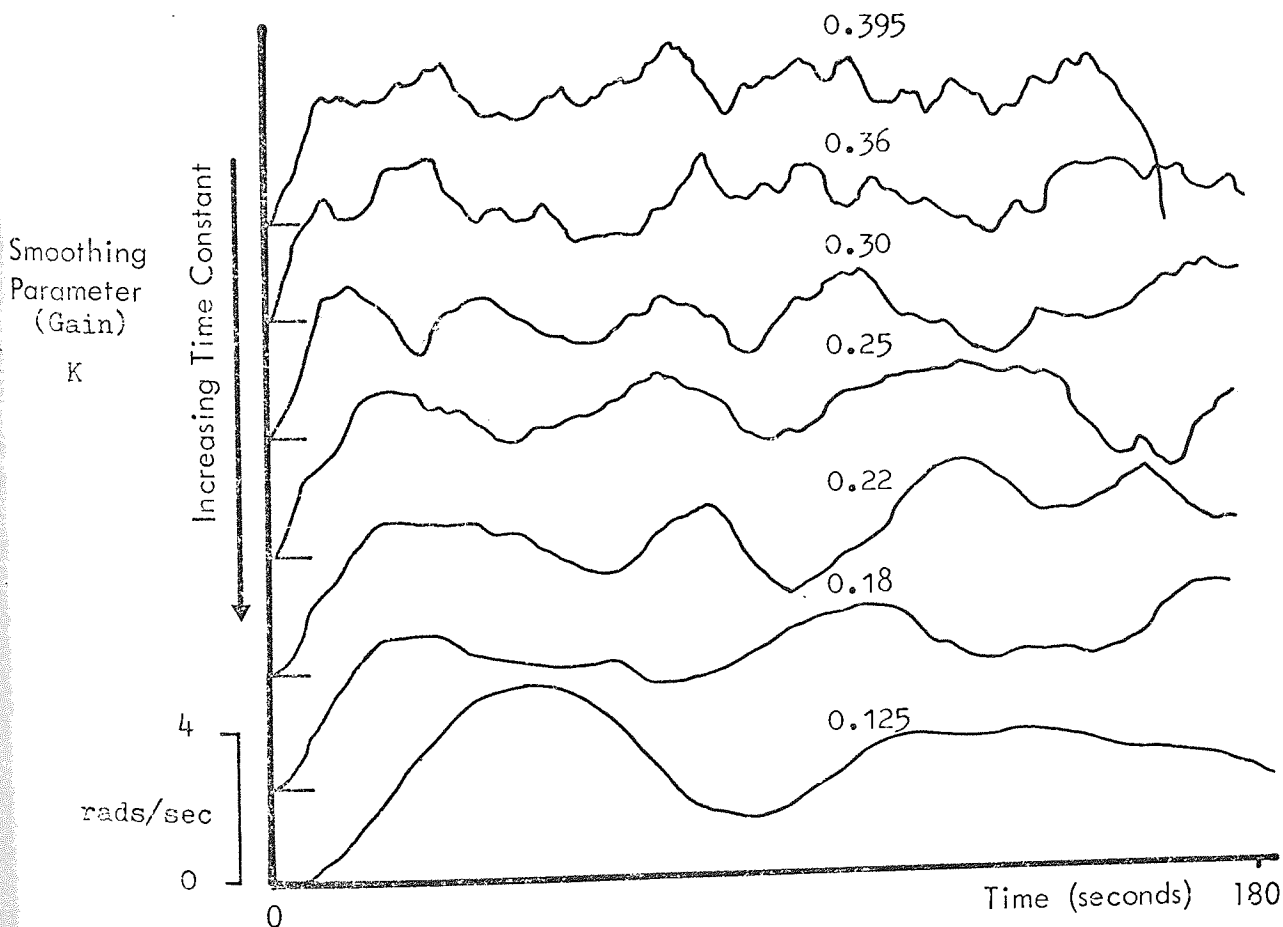
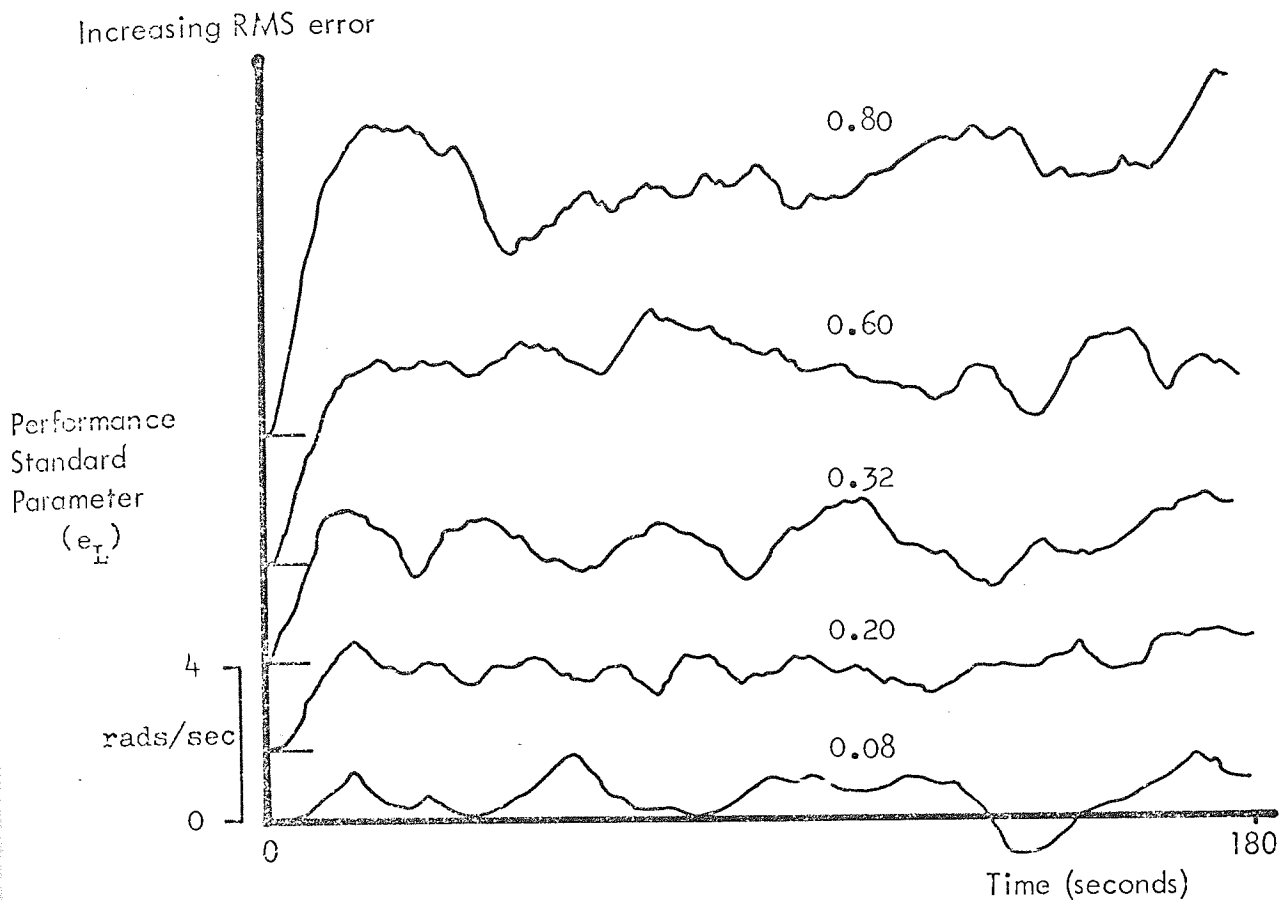

joystick of light alloy was made deliberately long to provide subjects with some opportunity to vary the 'biomechanical' gain of the control.

#### 2.4.11. Task Development.

During the task development phase the adaptive rate parameter  $K$ , and performance standard  $e_L$  were adjusted to suit the control behaviour of trial subjects. Learning characteristics associated with the adaptive task and the sensitivity of control behaviour to briefing statements were also studied.

#### 2.4.12. Adaptive Rate.

Parameter  $K$  in the adaptive logic equation controls the rate at which task difficulty rises and falls in response to changes in performance. The adaptive rate in this study was chosen to satisfy two requirements:

1. Changes in task difficulty in response to changes in performance should be imperceptible to the human operator.
2. The adaptive rate should not preclude loss of control and when it occurs there should be no doubt in the mind of the operator that the event has taken place.

To find the rate to satisfy these requirements 4 trial subjects were used who performed the adaptive task without vibration. Two were skilled and two were not. The task difficulty scores which resulted from one unskilled subject for the first 180sec. at each of seven rates between 0.125 and 0.395 rads/sec/sec. are shown in the lower half of Fig. 2.30. (the associated performance standard parameter was 0.5in.). It is

evident that the higher the rate the more 'notice' is taken of momentary changes in performance. The rate which was found most suitable from the point of view of the criteria was 0.3rads/sec/sec. and this value was set in the analog computer and remained fixed throughout the experimental trials.

#### 2.4.13. Performance Standard Parameter.

The performance parameter was chosen with reference to the size of display the nature of the control task and the constraint that it imposed upon the level of task difficulty attainable. The constraint imposed by each of five performance criteria is shown in the upper half of Fig.2.30. Note that increasing the performance standard produces an equal decrement in the average level of the task difficulty. As a result of trials with the same 4 subjects the performance standard parameter was fixed at a value which resulted in performance being controlled at mean error modulus equal to 0.6 inches of display movement. At this level of error the target line went off scale only when subjects lost control but provided sufficient line movement to keep subjects active and interested.

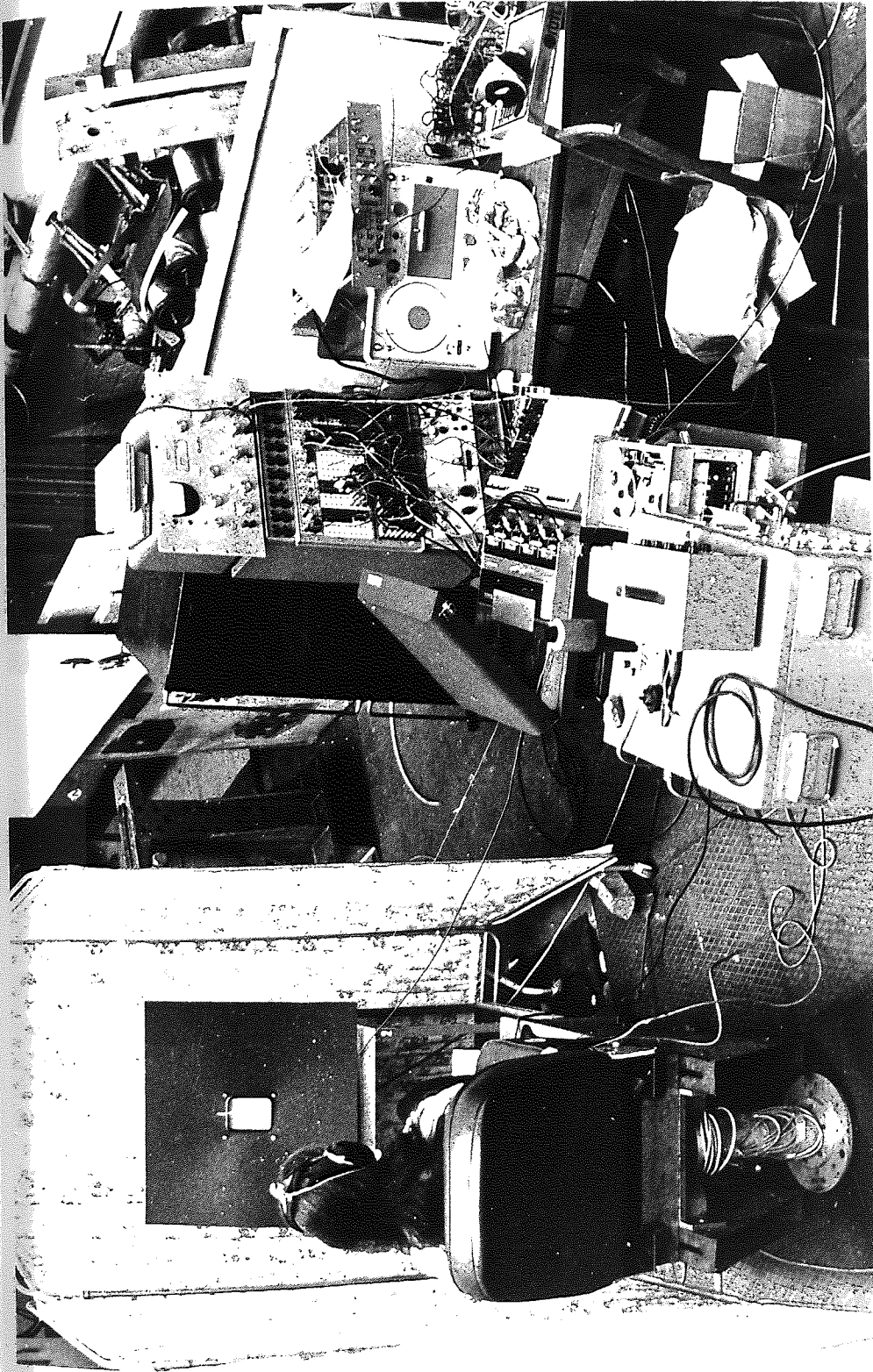

Photograph 2.

General view of experimental set up. Adaptive task computer in background, recording equipment centre and physiological measurement foreground.

#### 2.4.14. Learning

Learning to control a dynamic system is a trial and error procedure whereby the Human Operator adapts his behaviour and control policy to suit the dynamic idiosyncrasies of the system. If there are time delays (in the system) between stimulus and response the operator must try to cancel the delay by using his ability to anticipate. Sometimes it happens that the speed of response of the system is too fast, that is to say its gain (frequency response) is too high. In this case the human operator must cause the response to lag behind the stimulus and this he does by averaging or integrating. These operator functions are referred to as equalisation and intensive research with fixed simulators with visual inputs only has shown that in general lead or lag equalisation is adopted to give a 'roll off' in the man-machine open loop gain characteristic  $\frac{Y}{p_c}$  of -20db./frequency decade in the region of the gain-crossover frequency. This finding is the basis of the human operator "crossover" model; M<sup>c</sup>Ruer and Wier (1969). Lead-lag equalisation is used by the human operator to achieve stable operation of the system that is to give adequate stability margins; to obtain desirable stimulus response relationships; to suppress unwanted stimuli and to reduce the effects of system uncertainties. Having learned to stabilise the system etc. the next adaptive phase is optimisation. During this phase the operator trims his control behaviour - particularly his gain to minimise the effort required to satisfy the requirements of the manual control task. The time it takes to develop an appropriate equalisation policy and to optimise control behaviour depends upon the dynamic complexity of the system and the control skill of the human operator .

Measured and Theoretical Operator Gains  
 at various levels of Instability  
 ( After Jex et al, 1966)

Figure 2.31

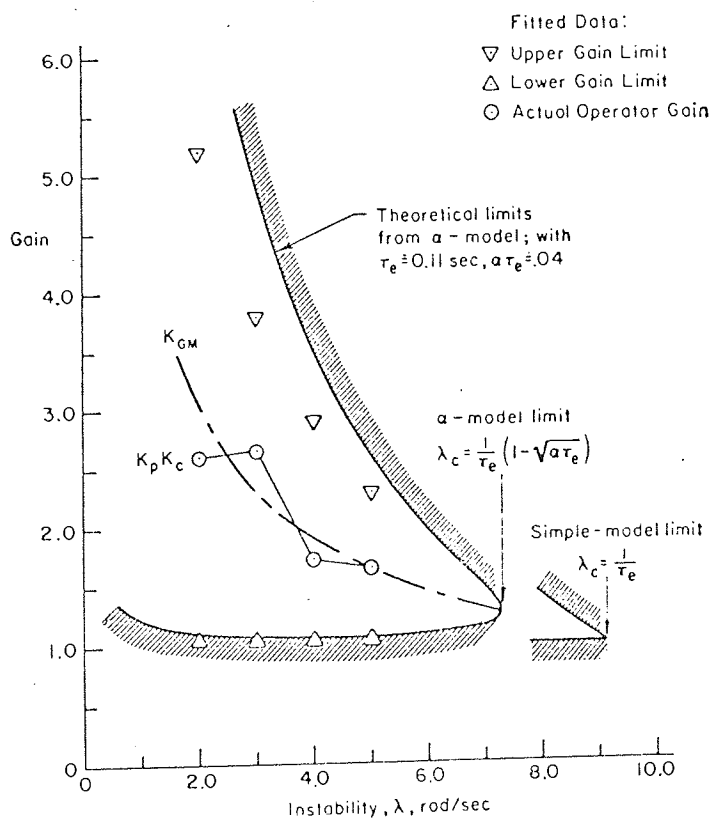

Analogue Computer Program

Figure 2.32

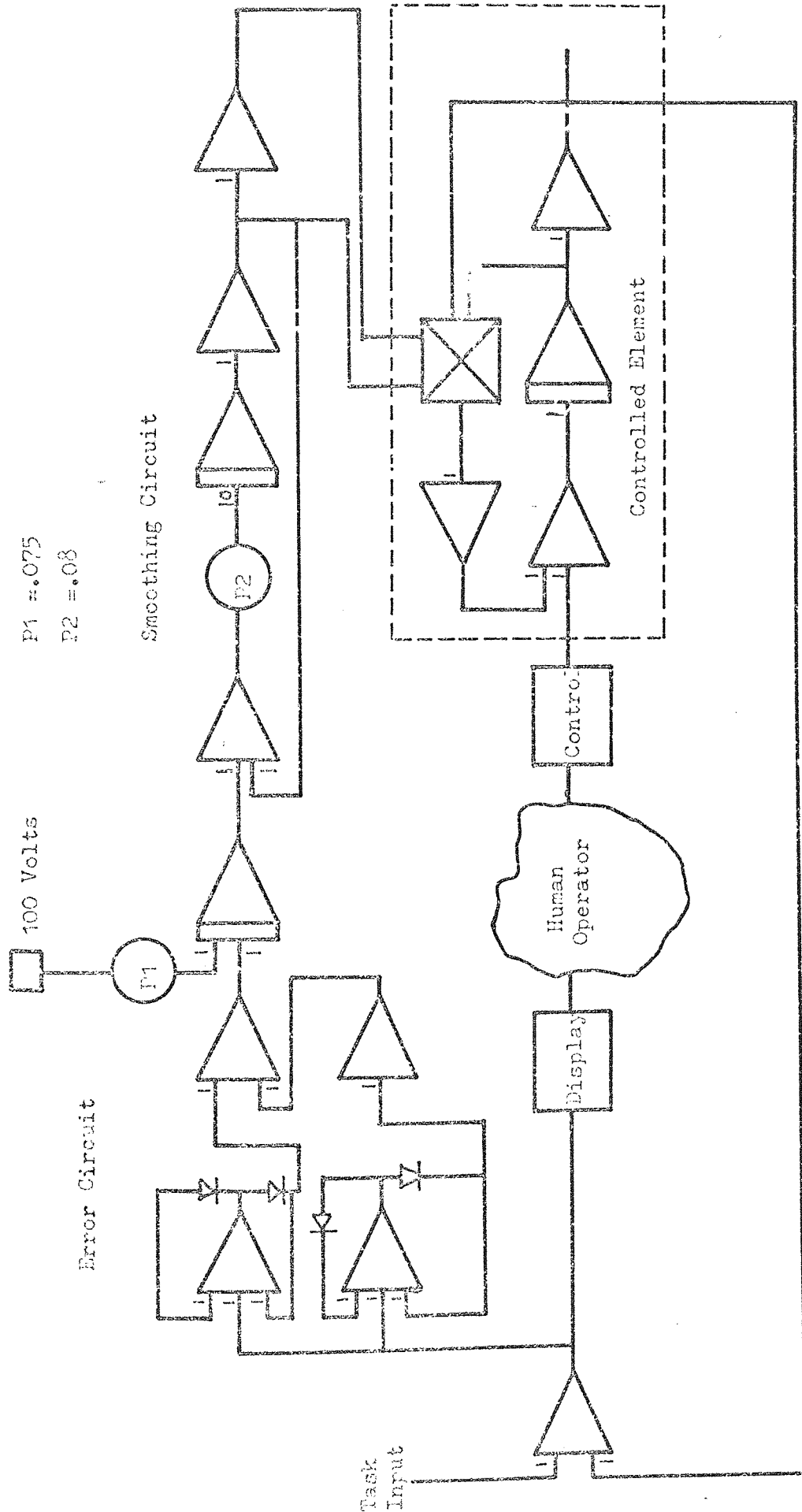



Records of Task Difficulty during Learning for one Skilled & one Unskilled Subject. The exhibits show the first 15 Mins on the first day of practice and last 15 Mins on the 4th day.

Figure 2.33

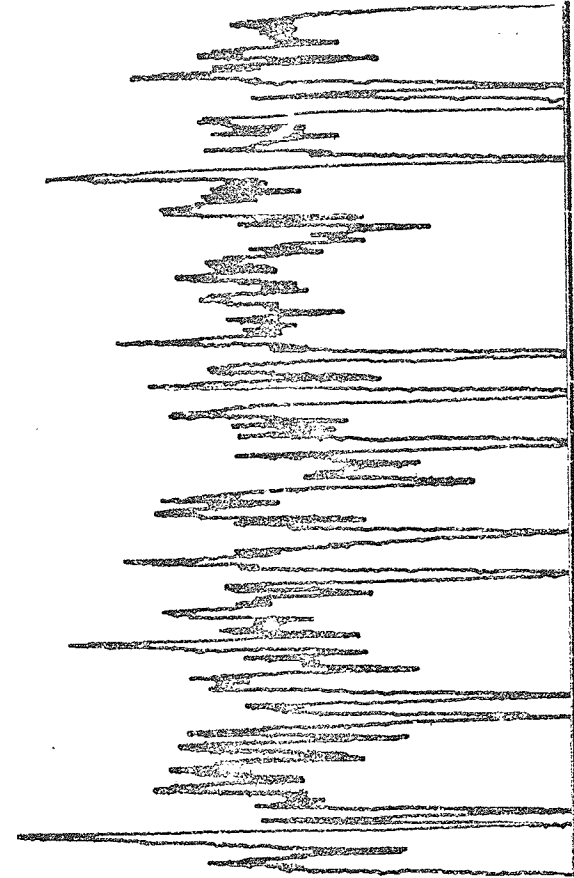

4th Day of Practice

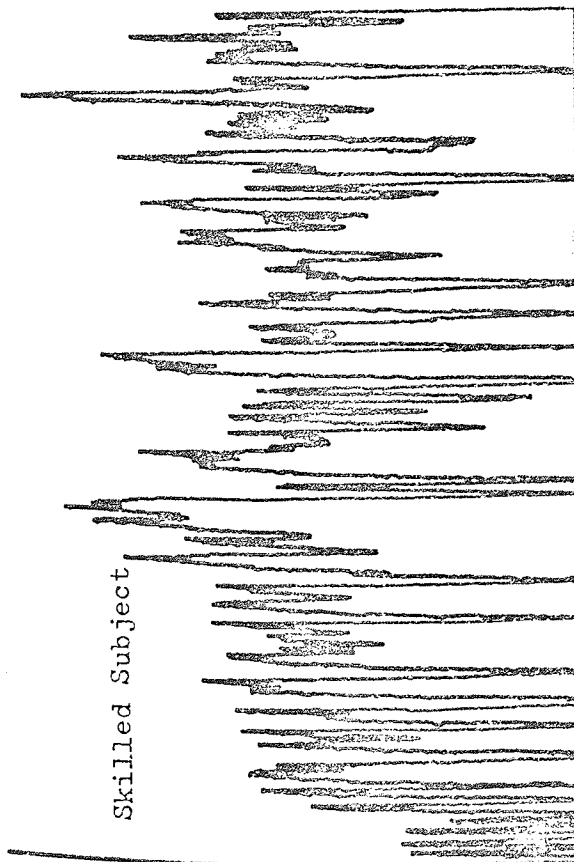
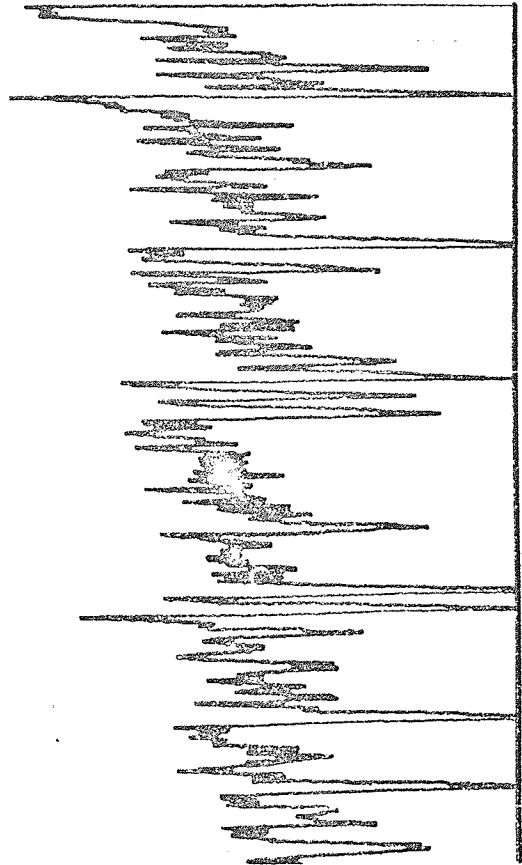

1st Day of Practice

Unskilled Subject

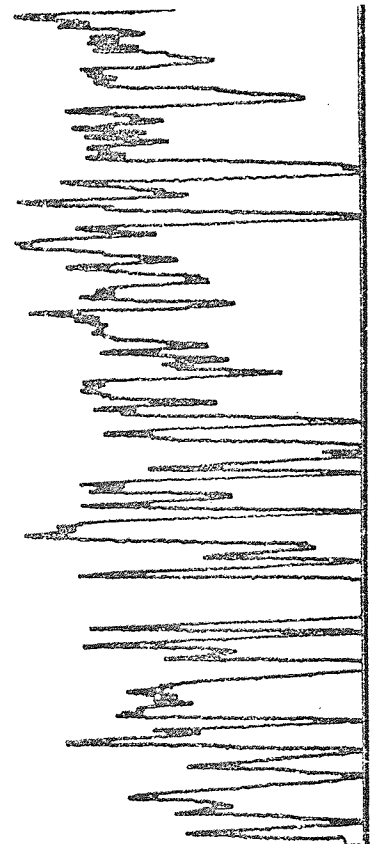

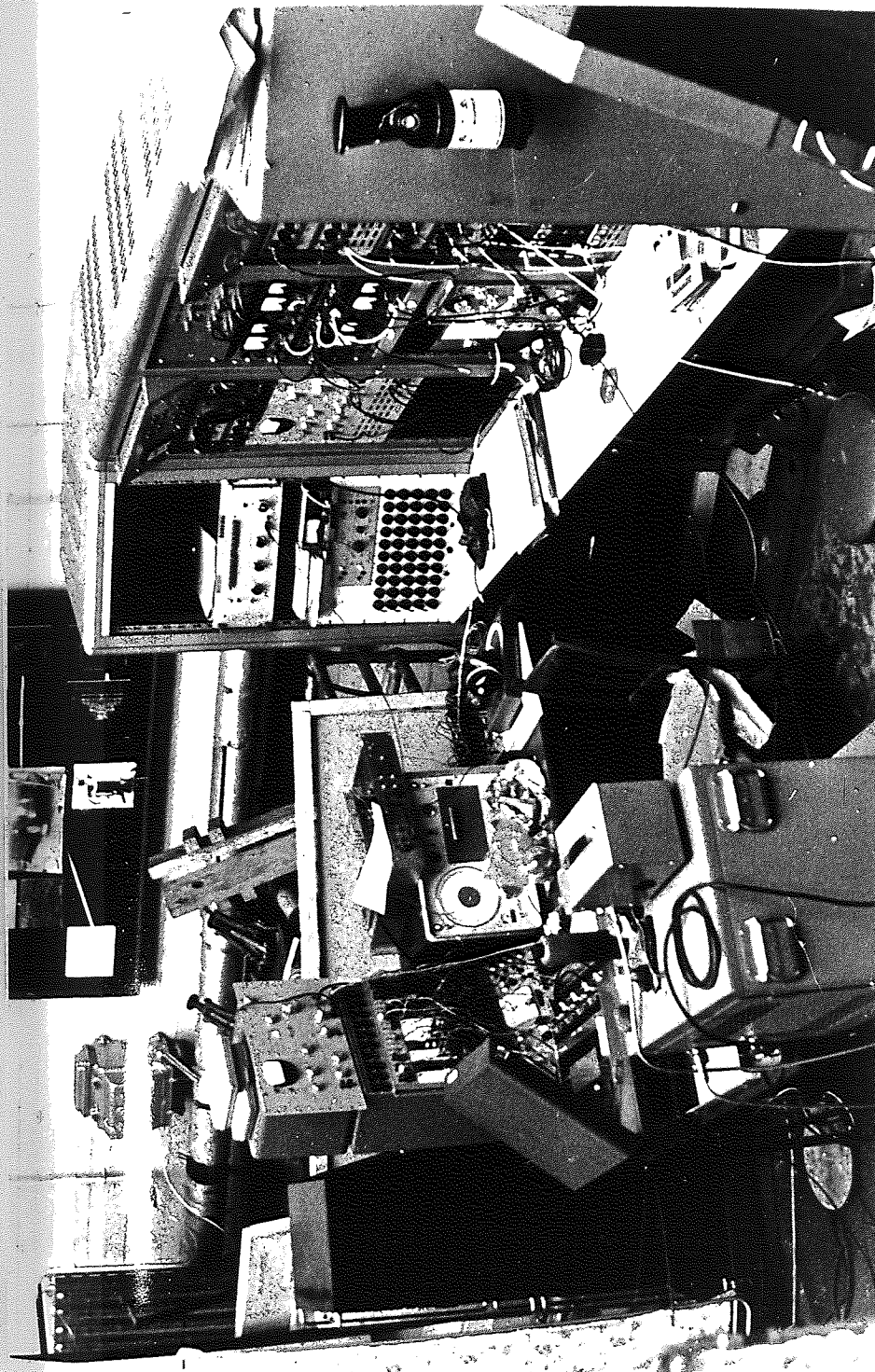

Photograph 3.

General view of control, measurement, monitoring and recording apparatus. Vibration control console on right. Subject performance control computers and task generator left.

The dynamic system simulated in this study was a variable first order instability. At low instability (low gain and task difficulty) the system behaves like a simple integrator which is perceived as a simple lag between stimulus and system response. To stabilise the system at low instability the operator therefore has to learn to introduce lead to compensate for the lag ( $e^{-ts}$ ). As the level of instability rises the speed of response of the system increases which means that lead equalisation must slowly be abandoned, gain must be reduced and efforts must be made to minimise reaction time if the operator is to retain control. Measured and theoretical operator gains were given by Jex et al. as a function of instability level. Their analysis in Fig.2.31 shows that the operator at low instability has a wide choice of gain which is progressively focused to a single critical value at "critical instability. If at any level of instability the human operator fails to adopt a gain value within the upper and lower limits shown control is lost.

In order to establish the training requirement for the adaptive task four new trial subjects - two male and two female - were studied during 1hr. trials on each of four consecutive days. Results for the first 15 minutes of practice on the first day and the last 15 minutes on the 4th. day are shown in Fig.2.33. note that the more experienced male was able to adapt quickly and reach his full capability in the first 5 minutes of practice.

Before practice began the object of the task was explained but no instruction was given on how to perform it . In the result of the less experienced female it is evident that a 'recognition milestone' was reached after about 7 minutes practice thereafter her control capability rose steadily and was continuing to rise at the end of the 4th. day. As a result of the learning trials it was decided that subjects for the final experiment

An Example of the effect of Control Criterion  
on Control Behaviour

Figure 2.34

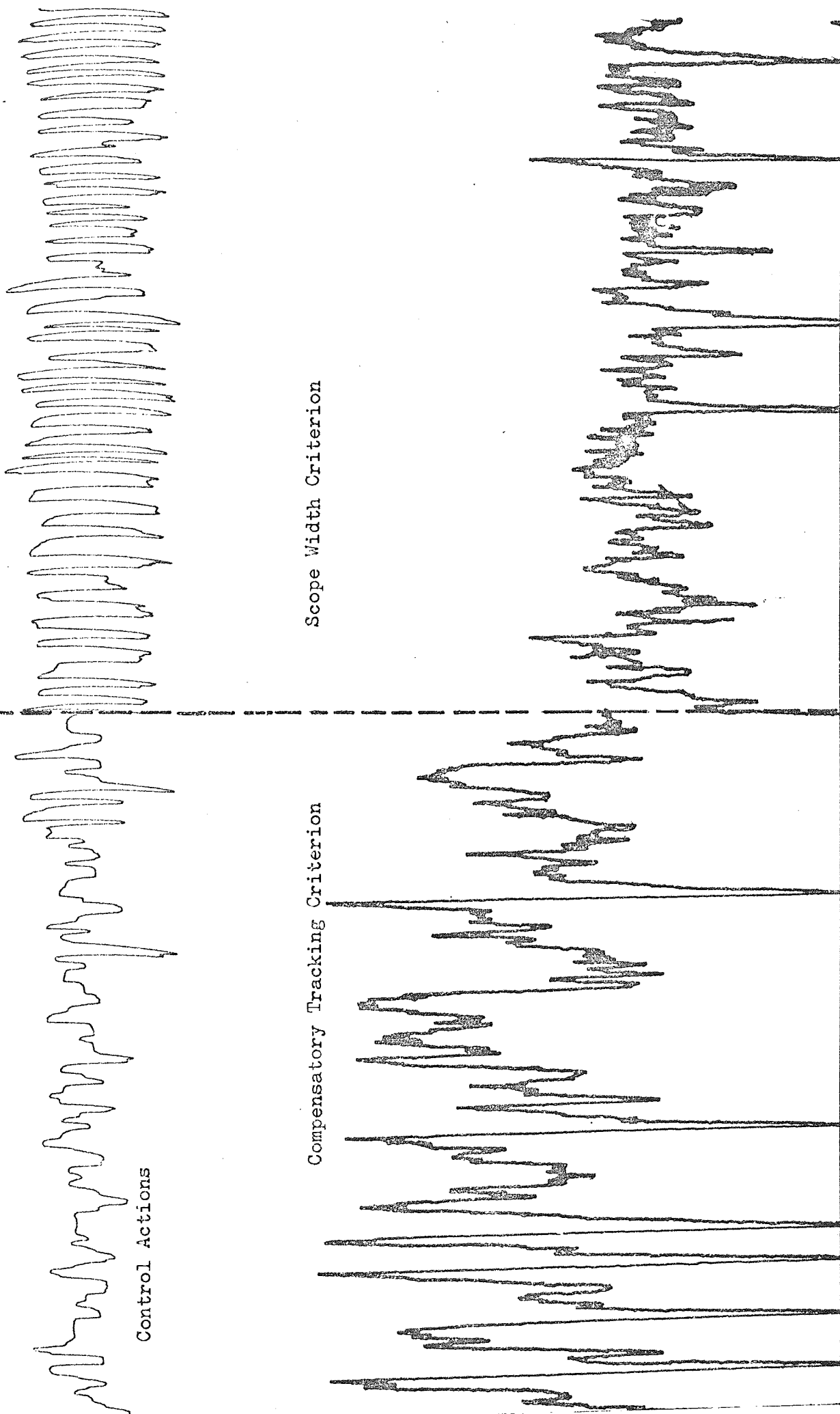

should practice without vibration until their ability reached a plateau and then with random vibration for  $\frac{1}{2}$  hour at 0.025 Rms'g'.

#### 2.4.15. Briefing.

Trials revealed that control behaviour was susceptible to briefing. Instructions to minimise deviations from the target centre line resulted in attempts to cancel the error with precise control motions as shown on the left hand side of Fig.2.34. When the instruction given was "keep the line on the oscilloscope" there was a marked tendency for subjects to use a bang-bang policy whose effect on task difficulty is shown on the right hand side of the figure. Bang-bang behaviour is a very good example of the human operator converting a stimulus-response situation into a response-stimulus problem. By using bang-bang motion the operator is concealing the input command signal and providing himself with predictable display movement which for the purpose of keeping the line on the screen requires him to control only the extremes of movement without bothering about what goes on in between. By this means the task is simplified and the operator is able to retain control with a saving in mental tracking effort but at the expense of increased physical effort and mean error modulus. The lower task difficulty score for bang-bang operation in Fig. 2.34 is a reflection of the increased error incurred. Loss of control is shown to have occurred 6 times when using precise tracking behaviour compared to 4 times when it was bang-bang, but it is important to emphasise that the causes were different. Loss during precise tracking it is seen was caused by instability but during 'bang-bang' operation it was due to a momentary lapse in attention, eg. blinking. This demonstrates that without continuous visual feedback, control was not possible- at no



Photograph 4.

Subject cubicle with experimenters recording and monitoring apparatus in the foreground.



time was it sufficient for the operator to merely wag the control from side to side. Bang-bang control is a very refined timing skill as distinct from precise tracking which is a space-time acumen.

As a result of these findings it was decided to issue three instructions and to include these as a factor in the experimental design. The instructions issued were :

- A) Minimise deviation of the moving line from the centre zero mark.
- B) Keep the line within the margins of the oscilloscope.
- C) Minimise deviation of the moving line from the centre zero mark and keep the line within the margins of the oscilloscope.

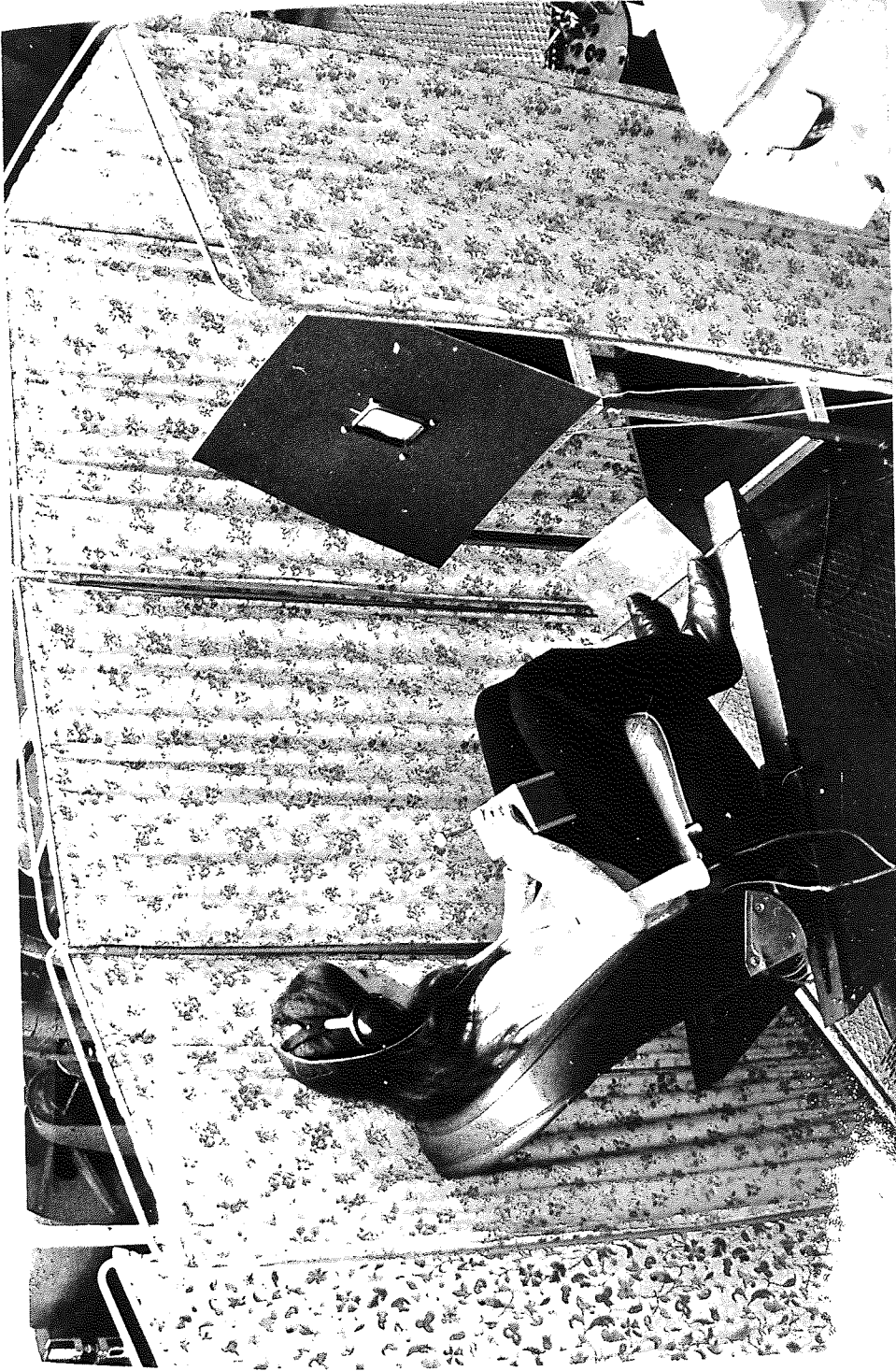

Photograph 5.

The task environment.



## 2.5.0. Experimental Facility

A schematic block diagram of the experimental set up is shown in Fig.

2.25. A control engineering representation of the same thing is shown in Fig.2.26 and photographs 1-8 provide a visual record of the general facility.

### 2.5.1. Vibration.

The vibration generator used was a part of the 4 jack vehicle vibration facility belonging to the University of Birmingham, Department of Mechanical Engineering. The single vertical vibrator was electro-hydraulic with a stroke of  $\pm 3''$  and frequency range 0-120 Hz.. Voltage waveforms at the input were converted into a displacement waveform at the jack by a position control system. The input voltage/acceleration output performance of the vibration facility has been described by Ashley (1969).

#### Vibration Waveforms

Random input waveforms were derived from a Solartron Random Noise Generator. It was intended that random vibration at the man/seat interface should be bandlimited to 25c/s. with spectral peaks at 5 and 12Hz. corresponding to major body resonance and secondary resonance respectively. The spectral peaks were obtained by passing Random Noise derived from the Noise Generator simultaneously through a pair of independent second order resonant filters simulated on the analog computer. Gains were 2.5 and 5.0 respectively for the 5 and 12Hz. resonances and the random vibration waveform was synthesised by adding filter outputs and passing the result

Vibration Filter.

Figure 2.35

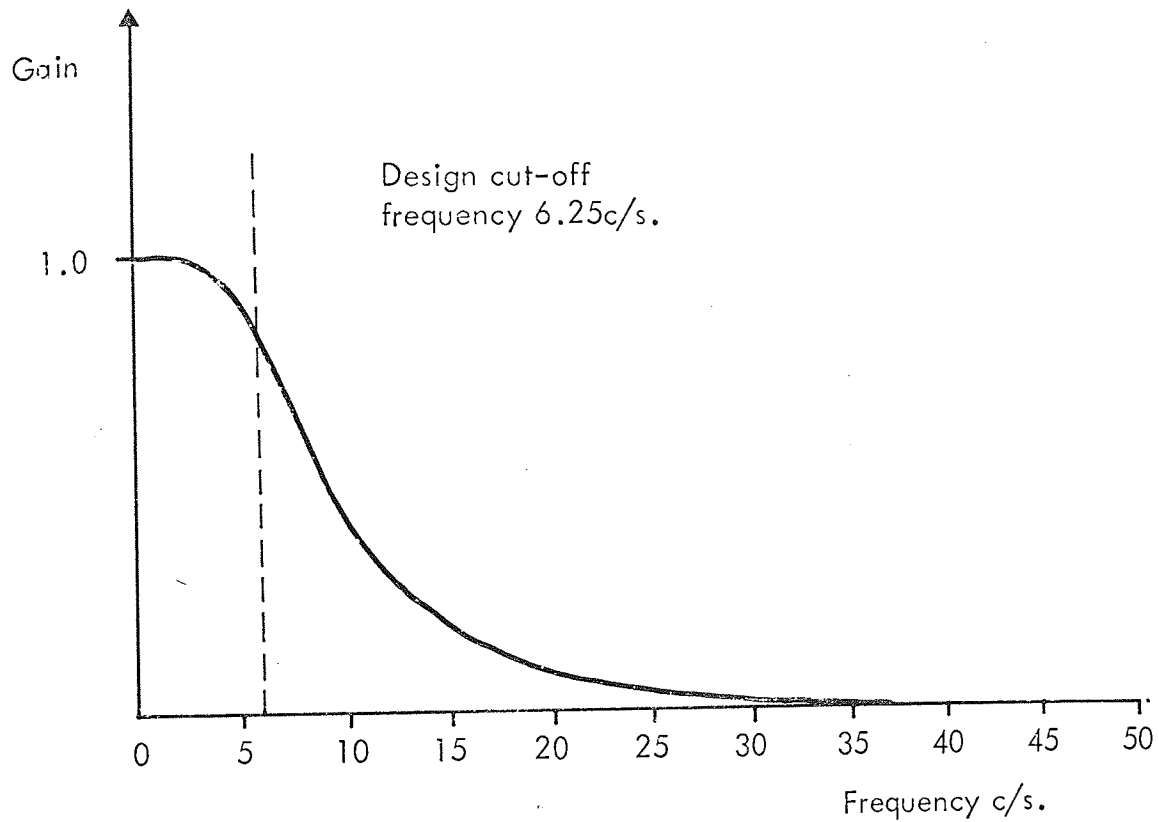
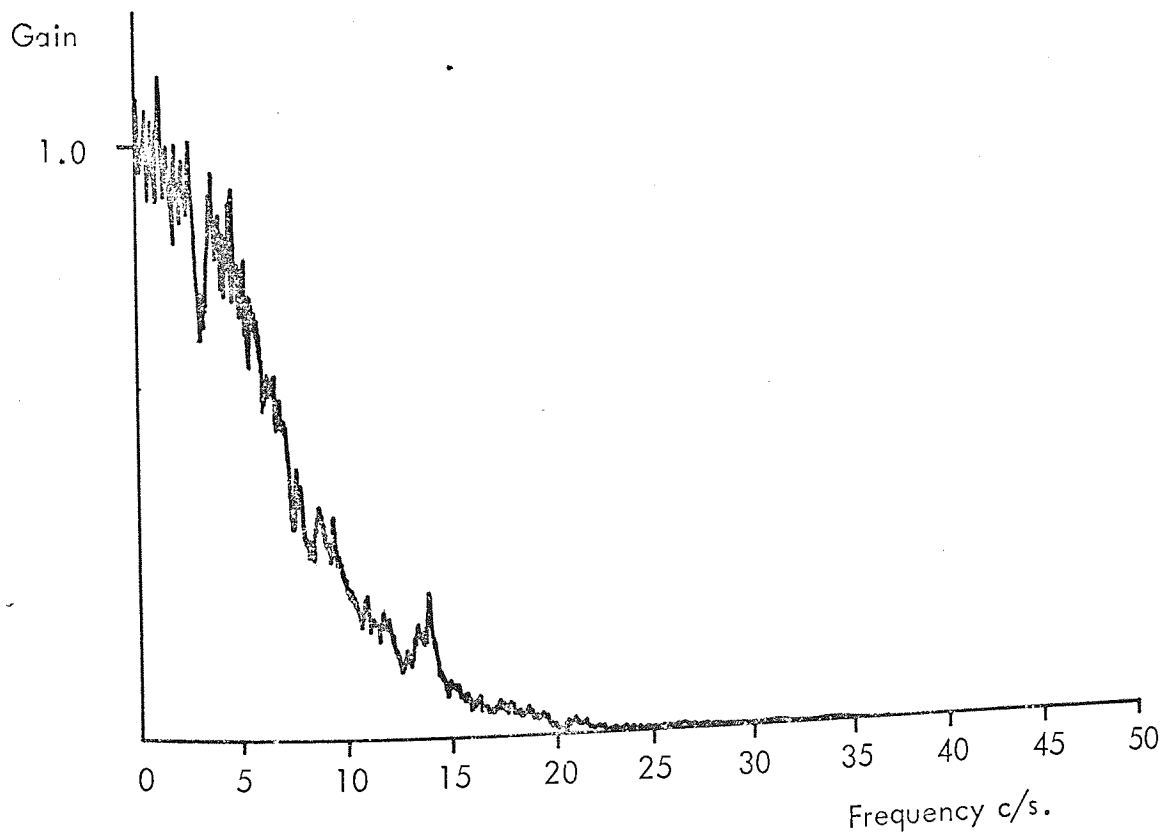
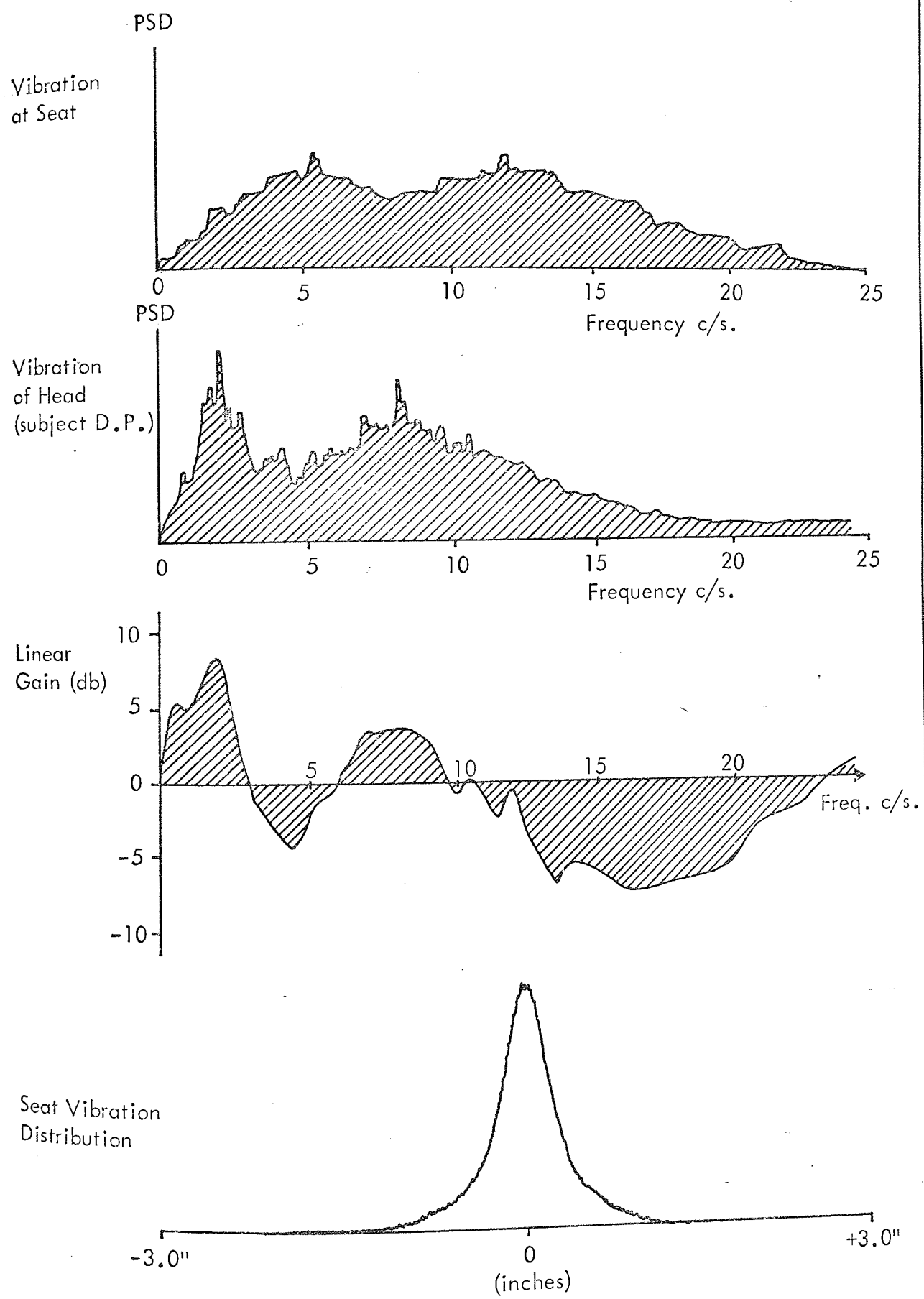

Figure Noise Input after Filtration.



Measured Vibration Characteristics (Analog Analysis).

Figure 2.36



through a low pass filter having an Equivalent Noise Bandwidth of 6.25Hz. as shown in Fig.2.35. This method of spectral synthesis has been described in more detail by Whitehead (1967). The resultant Acceleration Power Spectrum measured at the seat interface is shown in Fig.2.36, together with the displacement probability density, output spectrum at the head of a subject and vibration transmissibility through the body. Sinusoidal vibration waveforms were derived from a Quan Tech sinusoidal sweep generator.

#### 2.5.2. Adaptive Vibration.

In the second and third experiments reported vibration stress was linked to the adaptive variable. When this configuration was used the synthesised random or sinusoidal voltage waveforms were multiplied by the adaptive variable in the analog computer before being applied to the vibrator control system.

#### 2.5.3. Seat.

The seat was a passenger car seat whose back angle was fixed at  $20^{\circ}$  as shown in the photographs. When subjects were seated the combined seat-body mass system resulted in a resonant frequency of approx. 2-3Hz. dependent upon body weight. Seat belt restraint was not used.

#### 2.5.4. Vibration Measurement and Calibration.

Vertical vibration was measured at the interface between subject and seat, at the head and laterally at the control. At the subject/seat interface

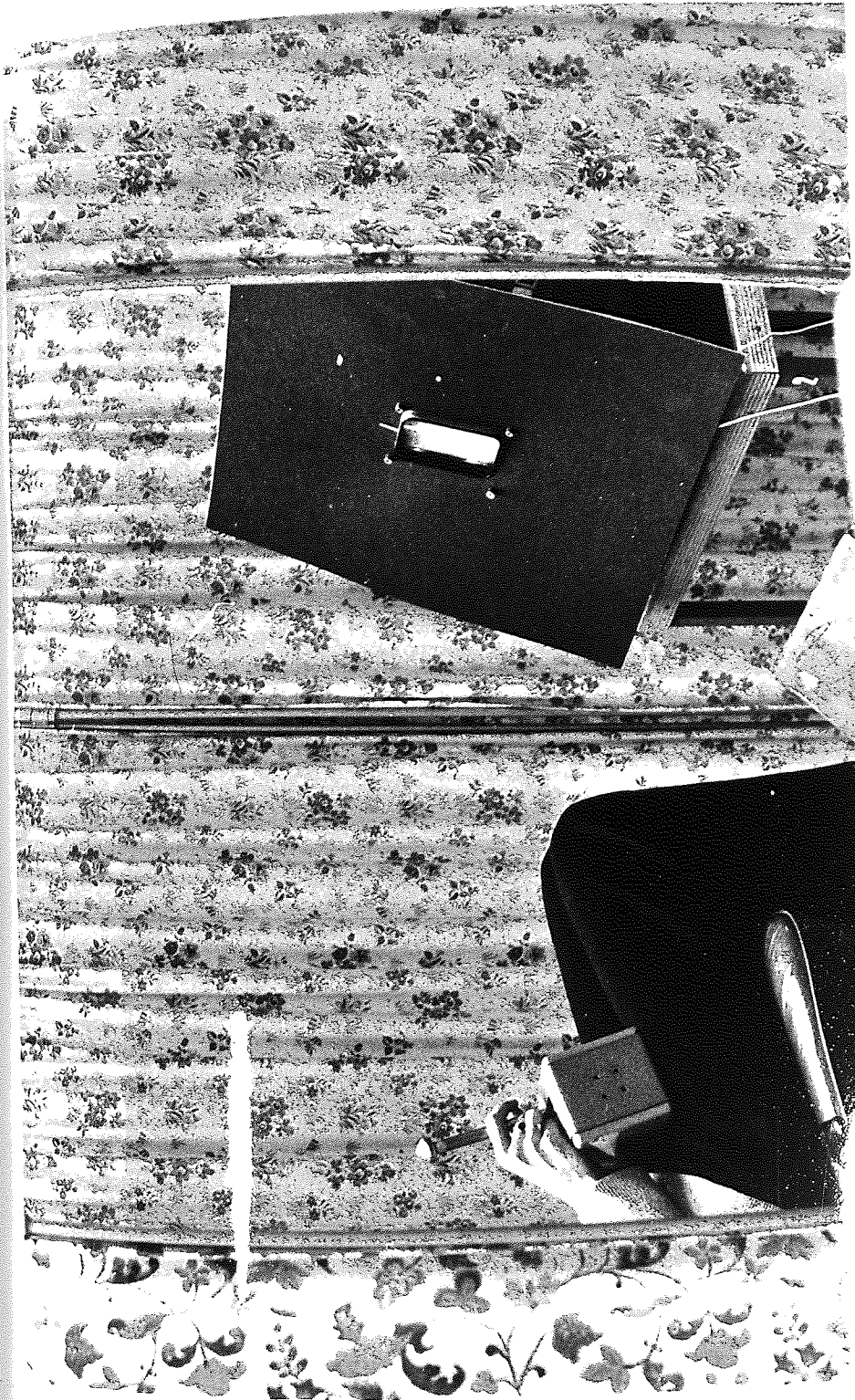

Photograph 6.

Subject cubicle viewed from monitoring position.

the accelerometer was mounted on an aluminium plate upon which the subject sat (photograph 1). At the head the accelerometer was mounted on top of the earphone headband. To prevent relative movement between the head and earphone headband, an elastic chinstrap was worn (photograph 7).

Rms 'g' at the subject/seat interface was measured with a Bruel and Kjaer Random Noise meter and displayed to the experimenter during experimental trials.

Vibration measurements were calibrated by  $\pm 1g$ . and  $0g$ . signals obtained by turning the accelerometers upside down and on their side. Calibration checks were carried out at the beginning and end of each subject trial.

#### 2.5.5. Physiological Measurement

Heart rate measurement during vibration proved successful, but EEG Evoked Auditory Potentials were unreliable. Consequently ECG measures only were obtained during experimental trials. Beckman surface electrodes in conjunction with a Beckman Type RP Electrophysiological System were used to obtain the ECG.

#### 2.5.6. Recording.

Task, vibration and electrophysiological variables plus commentary were recorded on FM magnetic tape. The two recorders used for this purpose are best seen in Photograph 4. The one to the left of the experimenters XY plotter was used to record :

- a) The tracking task input command signal
- b) Tracking error.



Photograph 7.

Head accelerometer and control.

- c) Operator control actions.
- d) The adaptive variable.
- e) The ECG.
- f) Voice comments and communication.

The four channel Thermionic recorder behind the XY plotter recorded :

- g) Subject-seat interface vibration.
- h) Head vibration.
- i) Control vibration.
- j) The adaptive variable / or control actions.

The use of two tape recorders was dictated by equipment availability. Ideally all ten channels of data should have been recorded on a single machine, in order to time lock each variable to any other. No attempt was made to synchronise the two tape recorders because checks revealed that tape speed differences were within 0.05% of each other, an accuracy which was regarded as sufficient for this research.

#### 2.5.7. Measurement Accuracy.

The aim was to achieve an overall measurement accuracy equal or better than 1%. To this end rigorous input/output checks were made at frequent intervals and gains etc. adjusted accordingly. It is therefore the belief that all measures equated in this thesis carry a measurement accuracy equal to or better than 1%.



#### 2.5.8. Communication.

A one way communication link was set up between experimenter and subject. This was used during trials to provide subjects with knowledge of results, when appropriate and to carry other instructions such as start and stop. The microphone used for this purpose can be seen in photograph 4 to the left of the XY plotter.

#### 2.5.9. Experimenters Station.

During trials the experimenter sat on the chair shown in Photos 2 and 3. Displays and controls which were an essential part of the experimenters function were organised into a convenient work space so that all important displays were visible and all controls to hand. In some cases this meant providing a control remote from the equipment where it was normally located. The vibration control equipment, for example, is housed in the console behind the experimenters chair and adjustments to vibration intensity would normally be carried out there. To avoid having to walk about the vibration control was placed to hand in front of the experimenter and can be seen to the right of the XY plotter in Photograph 8 which also shows the analog computer controls, the sweep sine wave generator on top of the analog computer and task input generator to the right of the analog computer.

The experimenters controls and displays included :

- Display (a) The state of the adaptive variable on the XY plotter
- (b) Rms 'g' on the Bruel and Kjaer meter.
- (c) A partial view of subject, control and tracking task

(d) Heart rate.

Control :

(a) Vibration intensity.

(b) Vibration type - random or sinusoidal.

(c) Vibration mode - manual intensity adjustment or adaptive  
(automatic control).

(d) Recorder controls.

(e) Analog computer - compute/off/freeze/reset.

(f) Vibrator abort button which could be used in emergency to  
'kill' the vibration hydraulic system

During experimental trials the hospital screen was used to form an experimental cubicle, was positioned as shown in photograph 6. This enabled the experimenter to observe control actions and vibration without distracting the subject.

2.5.10. Subject Safety.

Vibration intensity was alarming only during sinusoidal vibration tests otherwise it was below  $0.1R_{ms} 'g'$  - a level frequently found in motor cars. Safety measures included an abort button for use by the experimenter and clipping of the random vibration waveform to prevent the hydraulic jack hitting its top and bottom stops. The facility itself included a fire extinguisher, first aid kit and was located close to the University Medical School. Subjects were not medically screened before vibration trials but were questioned about their medical history. As a result two volunteers were turned away because it was thought unwise to expose them to vibration.

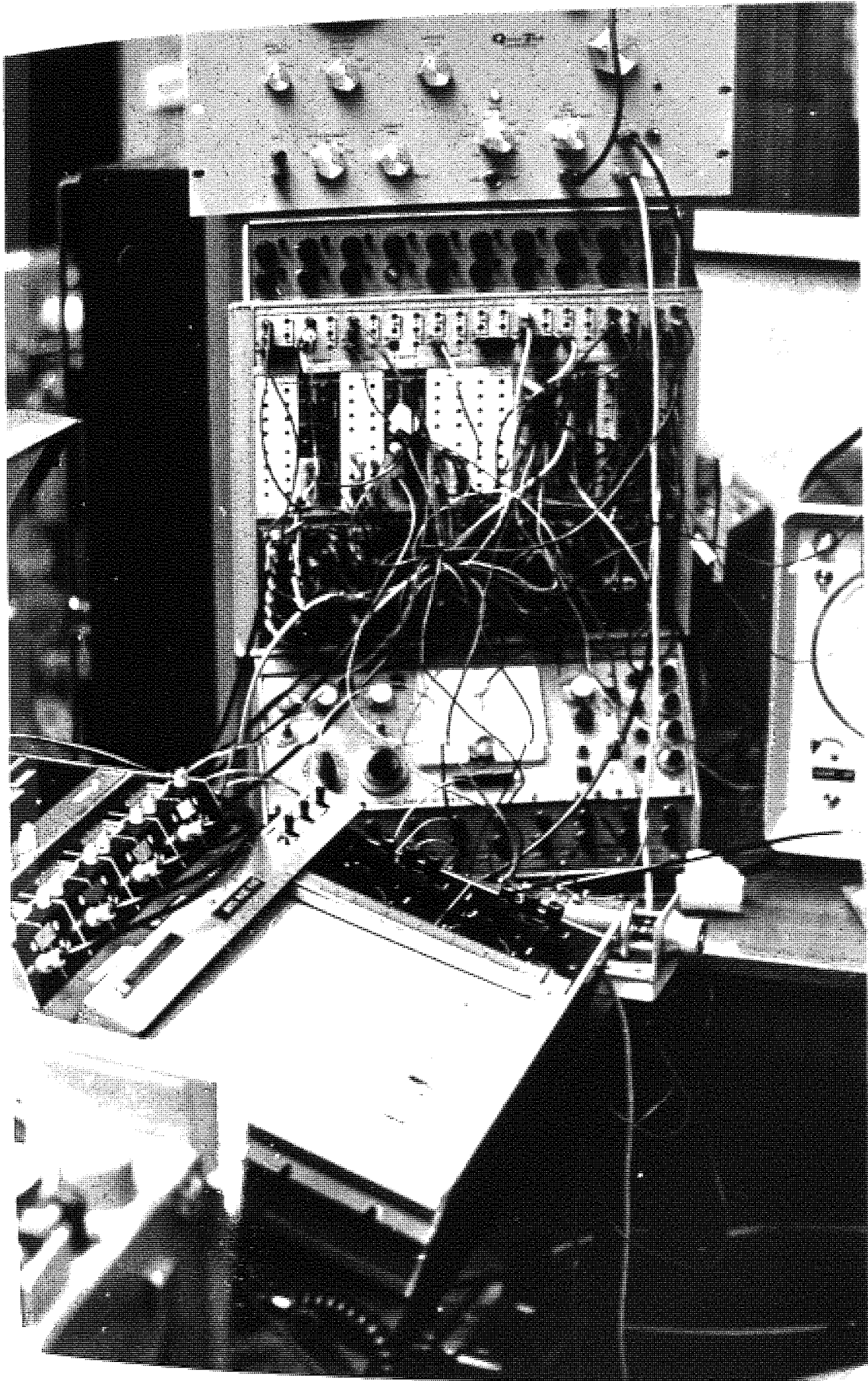

Photograph 8.

2.5.11. Task Environment.

Ambient environmental conditions in the vicinity of the vibrator were measured at roughly weekly intervals. Dry bulb temperature was 58-64°F., relative humidity 55-65%. light level 380 Lux in artificial light rising to 600-700 Lux with sunshine daylight. Noise which was generated by the vibration rig masked all other noise sources present at the time of testing. Average noise level was 84 dbA at the vibration seat. Spectrum analysis revealed it to have two dominant frequency components at 100 and 400Hz. This gave it a very distinctive sound. Earphones were worn by subjects during trials which were thought to attenuate the noise level by 8-10dbA.

2.6.0. EXPERIMENT 1. On the effects of random vertical vibration on the difficulty of a manual control task.

This first experiment was aimed at discovering what happens to the difficulty of a manual control task when a human operator is random vibrated at levels below 0.1 Rms 'g'. The task used was that described in section 2.4. with the performance criterion set at 0.6 inches and the adaptive rate at 0.3rad/sec/sec. The adaptive variable  $\lambda$  was the index of task difficulty and the experiment involved 30 minutes exposure to both stationary and non-stationary vibration. Different control objectives were issued to subjects between trials and a strict training schedule was observed.

2.6.1. Subjects.

It was expected that changes in the index of difficulty would relate in some way to degree of skill and experience in coping with vibration. To explore this possibility and to gauge the range of likely effects on the index a heterogenous group of seven subjects was formed ranging from a housewife with no driving experience to a test pilot. Two subjects were female aged 22 and 25 years. The male subjects were aged 24, 28, 29, 36 and 43 years. All subjects passed an eye test, none wore glasses and all were right handed. During trials subjects wore pullovers and cardigans instead of loose jackets. Payment was made to subjects at 50p. per hour but payment was made conditional upon full completion of trials.

2.6.2. Waveform analysis considerations.

In order to achieve, a priori, a known confidence in the results of waveform

analysis it is necessary to pre specify the length of record. The plan was to record task and vibration waveforms and to perform a variety of analyses the most important being frequency analysis. It was shown in Part 1 that :

$$\epsilon^2 = \frac{1}{BT}$$

where  $\epsilon$  is the standard error in the estimate of power spectral density obtained by analysis with a filter whose equivalent noise bandwidth is  $Bc/s$ , with averaging time (or record length)  $T$ secs..  $B$  it, was shown in part 1, is chosen with reference to the width of spectral peaks that one expects to find in the waveform to be analysed. In the case of these waveforms we can estimate what this is. Without prior knowledge it would have been necessary to perform a pilot waveform analysis to find the width by trial and error.

The sharpest spectral peak in the vibration waveforms is likely to occur at the resonant frequency of the subject on the seat ie. about 3Hz.. The width of the peak at this frequency we would expect to be about  $4c/s$ .. To properly resolve spectral peak the bandwidth of spectrum analysis should be  $\frac{1}{4}(f_2-f_1)$  Whitehead (1965, Table V), where  $f_2$  and  $f_1$  are the upper and lower sideband frequencies of the spectral peak - so that for analysis of the vibration waveform  $B = 1.0Hz$ . Consequently to keep standard error within 10% the length of the record must be :

$$T \geq \frac{1}{B\epsilon^2} = \frac{100}{1} = 100secs. = 1min. 40sec.$$

For the control task waveform we want to resolve each of the sine wave input components the minimum displacement of which was 0.05Hz.(0.31rads/sec.). To do this we used a filter 0.0125Hz. in width and to maintain a standard error

of 20% with such a filter the length of record for power spectral analysis must be :

$$T = \frac{1}{B\epsilon^2} = \frac{1}{0.0125 \times 0.04} = 2220\text{sec.} = 37\text{mins.}$$

Being the longer of the two records this ideally should have been the basic analysis epoch for the task waveform but the constraints of the recording equipment limited each record to a length of 30mins. This interval of time was therefore adopted as the duration for the experimental trials.

### 2.6.3. Experimental Design.

Each subject was assigned to 4 experimental conditions with two repeated trials in pseudo random order. Because of their heterogenous nature subjects each acted as their own control for the twelve thirty minute trials. The conditions were as follows :

- A - Non stationary vibration - 0-0.08Rms'g' with the instruction to minimise deviation of the moving line from the centre zero mark.
- B - Non stationary vibration - 0-0.09Rms'g' with the instruction to keep the line within the margins of the scope face.
- C - Non stationary vibration - 0-0.09Rms'g' with the combined objective: minimise deviation of the line and keep the line on the scope face.
- D - Stationary vibration - six five minute fixed levels of vibration in random order of intensity between 0-0.09Rms'g' each with the instruction given in C above.

### 2.6.4. Vibration.

Vibration intensity was limited to 0.09Rms'g' or to a lower level which

Figure 2.37

Normalised Power Spectral Density of Acceleration measured at the Subject/Seat Interface.

Spectrum is the Average of the Input Spectra for 4 Subjects.

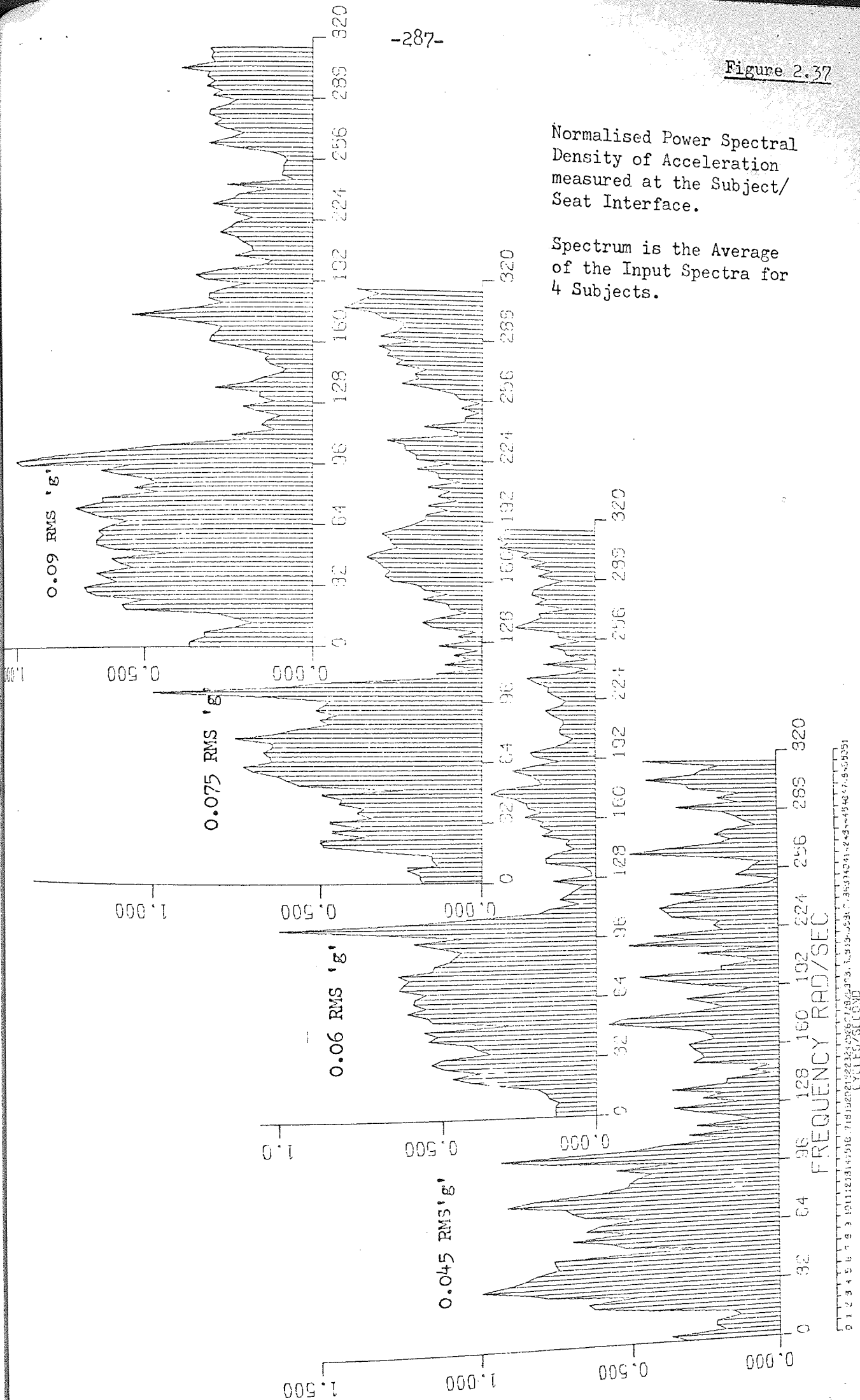



subjects themselves were asked to judge. This judgement was given at the end of a 30 minute training session at 0.025Rms'g' when the intensity of vibration was slowly raised by the experimenter until subjects declared that they felt "significantly uncomfortable". The same question was asked again after the first, second and third trial period and resulted in permission being given to raise intensity. When subjects reached their first trial under condition D their voluntary limit at that time was divided by six to give the fixed vibration levels. On repeated trials intensity was always limited to the same value.

Measured acceleration PSD and displacement APD at the subject/seat interface are shown in Fig. 2.36. The PSD, which was obtained by analog analysis, shows power peaks at 5Hz. and 12Hz.. The displacement APD shows that displacement at the interface was Leptokurtic Symmetrical with standard deviation equal to 18% of the peak displacement value. The Acceleration and Velocity APD's. were the same shape and the APD profile was the same at all Rms'g' levels, but the PSD was not. The results of digital PSD analysis at 0.045, 0.06, 0.075 and 0.09 Rms'g' are shown in Fig. 2.37. Note that the spectral power distribution changes between 0.045 and 0.06Rms'g' and that the vibration waveform at the subject/seat interface appears to contain a sinusoidal contaminant at 15-16Hz. Peak acceleration levels corresponding to the above Rms'g' levels were  $\pm 0.25g.$ ,  $\pm 0.33g.$ ,  $\pm 0.416g.$  and  $\pm 0.5g.$  respectively.

The non-stationary vibration condition was obtained by manual adjustment of the vernier gain control. The Rms'g' non stationarity profiles were roughly a half cycle sinusoid . Examples of the actual non-stationary profiles are given in Figs. 2.39-2.42.

2.6.5. Procedure

In the initial brief it was explained that the purpose of the tests was to determine to what extent vibration effects manual control performance and that the tests would involve twelve  $\frac{1}{2}$  hour trials under four experimental conditions but the conditions were not specified. Subjects were told that their performance during trials would be communicated to them at 5 minute intervals but they were not told that the task was adaptive.

During practice sessions instructions were given to minimise deviation of the moving line from centre zero and to keep the line on the scope. Practice began without vibration and continued until subjects showed visible signs of having reached the plateau of their ability. At this juncture one 30 minute practice session followed with stationary random vibration set at 0.025Rms'g' and subjects then moved on to the main program of twelve trials. The minimum practice period without vibration was 30minutes. The most skilled subject in the group reached his plateau within this period. The least skilled subject took seven practice sessions before stabilising. For use during the 12 measured trials subjects were each given an appointment card and asked that they turn up at the same time each day and to inform the experimenter should they notice any unusual change in their physical condition or state of mind. Preparation involved attachment of surface electrodes to the chest, attachment of earphones and head accelerometer and connection to the instrumentation. Whilst being prepared subjects were given the instruction appropriate to the trial condition which was followed by a five minute practice period during which time instruments were checked, calibrations made and the machine started. Trials involving stationary vibration began with the appropriate intensity level which continued for

Results of Experiment I - Individuals.

Figure 2.38

- a Expt. Condition 'A' - Non Stationary Vibration
- b Expt. Condition 'B' " " "
- c Expt. Condition 'C' " " "
- d Expt. Condition 'D' Stationary Vibration
- Falling Vibration Intensity

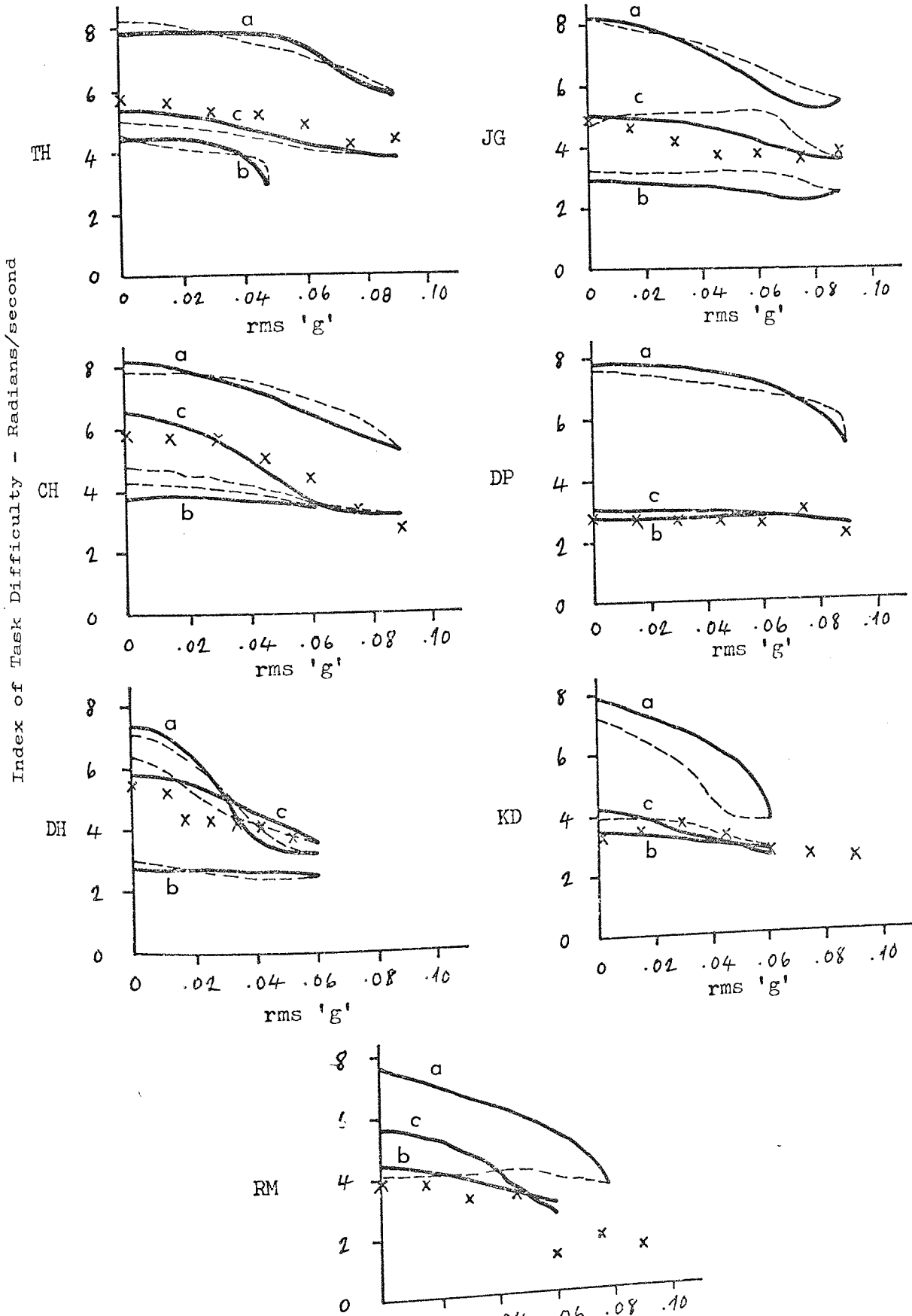

Experimental Condition 'B' - An Example of results obtained with Adaptive Task.

Figure 2.39

Figure 2.39 Subject T.H. Adaptive Task Performance.

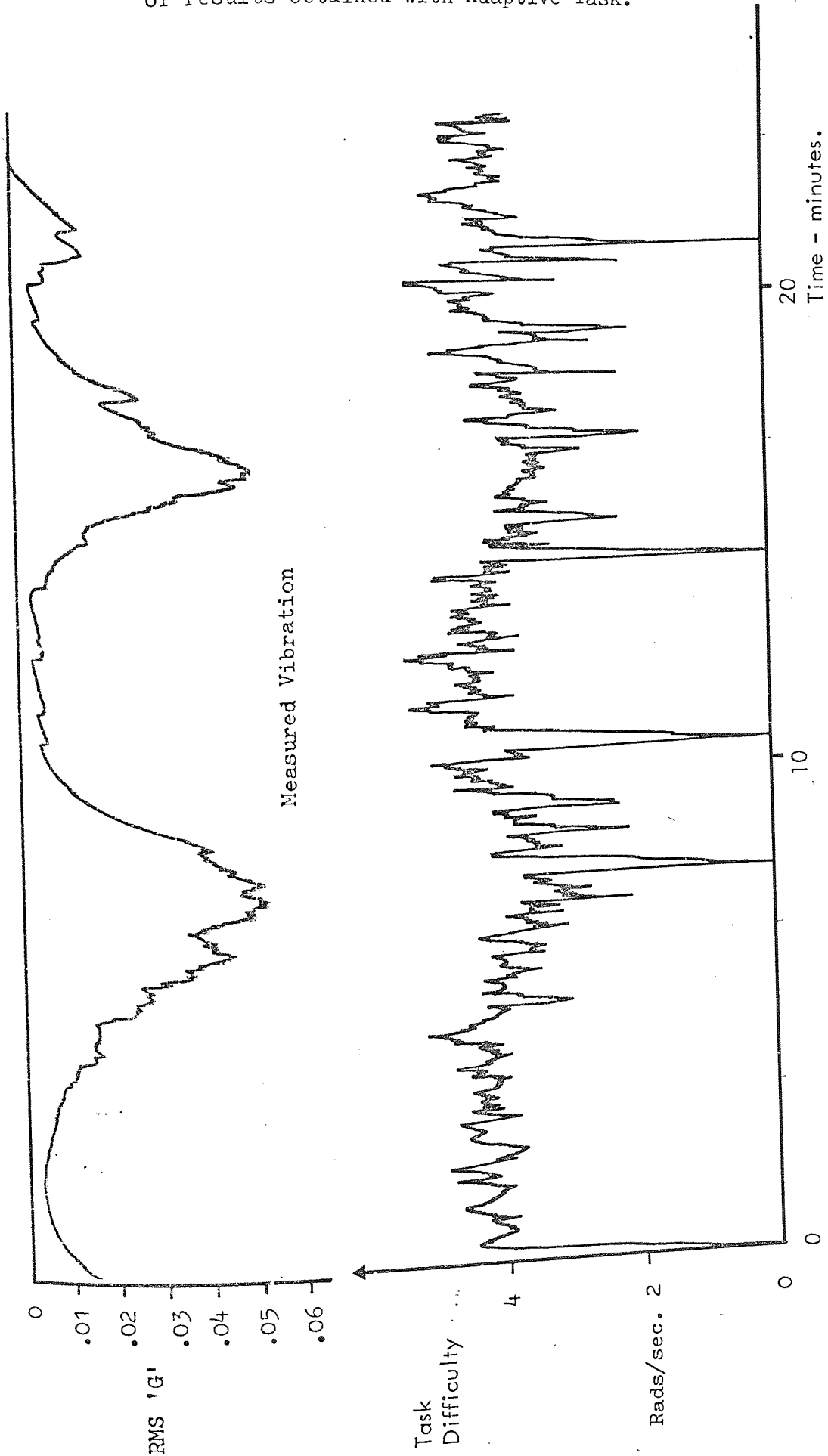

Experimental Condition 'B' - An Example of the Effect of Non Stationary Vibration upon the Difficulty of Adaptive Control Task.

Figure 2.40

Figure 2.40 Subject D.P. Adaptive Task Performance.

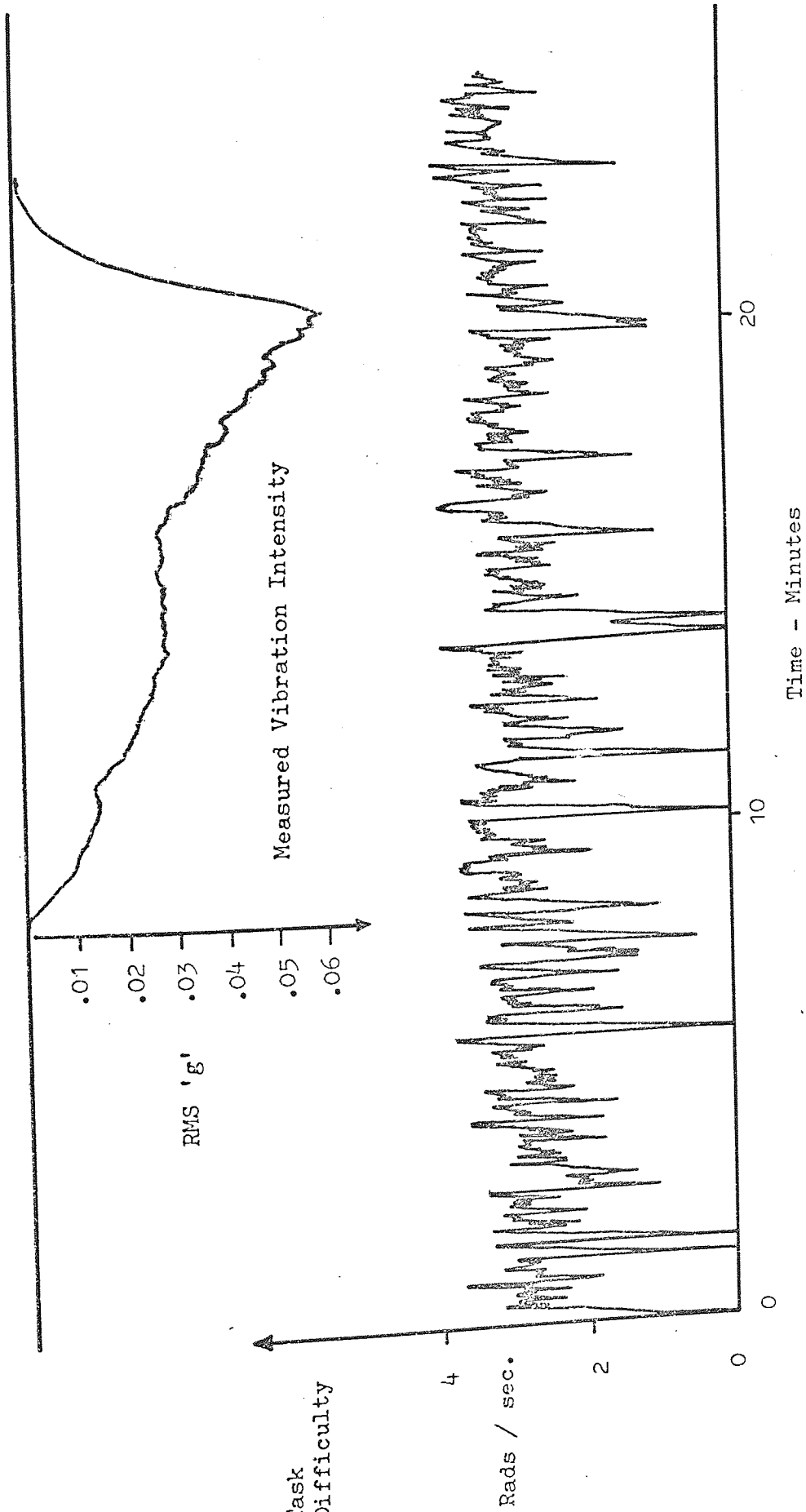

Subject R.M.  
Adaptive Task Performance.  
Experimental Condition 'A'

Figure 2.41

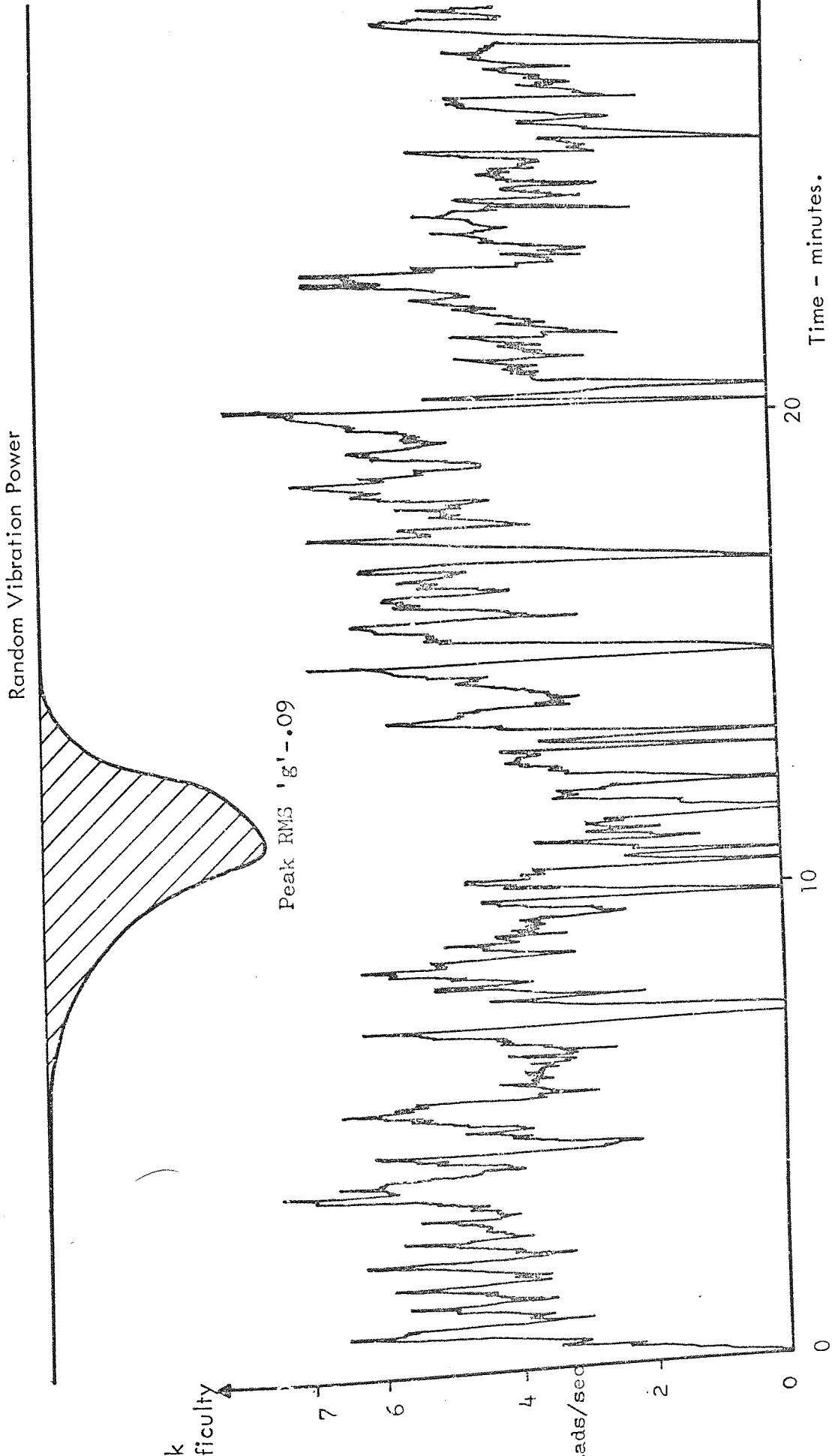

Experimental Condition 'C' - An Example of results obtained with Adaptive Task

Figure 2.42

Subject K.D.  
Adaptive Task Performance.

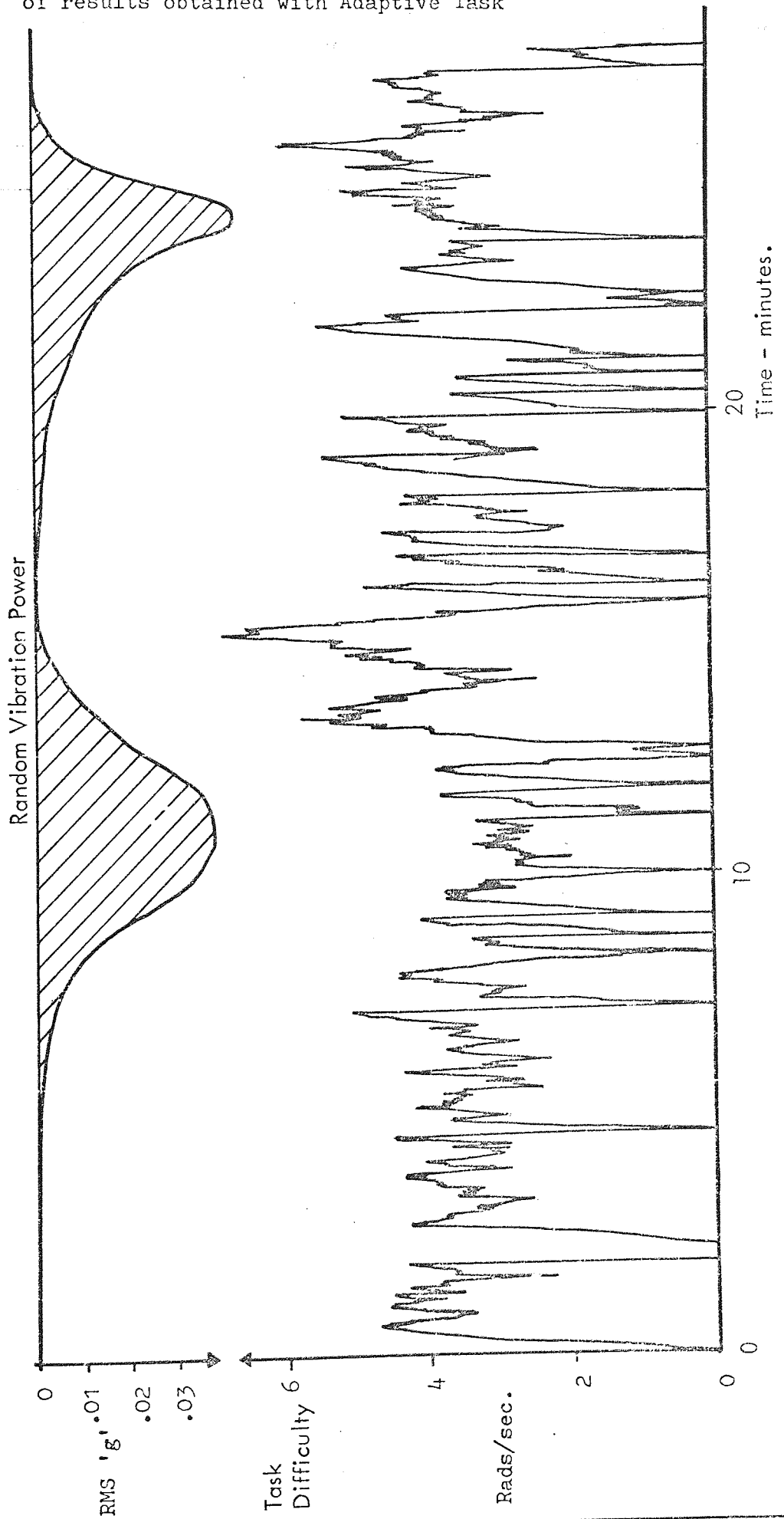

five minutes before being changed to the next value and so on for 30 mins.. When the vibration condition was non-stationary the trial began without vibration. Subjects were not told when the non-stationary cycle would begin or when it would end.

All trials began with the task set at zero difficulty. After 5 minutes on the task and subsequent intervals thereafter, subjects were given a score via the headphones. From time to time they would loose control. When this happened the computer was reset by the experimenter and the task was begun again at zero difficulty. After the first, second and third trial periods subjects were asked to re-assess their subjective vibration limit. Finally it is important to emphasise that at no time either during training or subsequently during the trials proper were subjects told how to control. Consequently the control policies that they adopted were entirely of their own making.

#### 2.6.6. Results.

Task difficulty scores plotted against Rms 'g' vibration intensity are shown in Fig. 2.38. for each of the seven subjects and for each of the four experimental conditions. The scores shown are the average of repeated trials and averaged with respect to time. The scores have been corrected to take account of the difficulty imposed by the performance standard (an effect demonstrated in Fig.2.30). Examples of the raw results from which those in Fig.2.38 were obtained are shown in Figs.2.39-2.42. Each is the result of a single trial under experimental condition B in Figs.2.39 and 2.40, condition A in Fig. 2.41 and condition C in Fig. 2.42. These four trials are shown because they were the subject of detailed analysis. An example of performance



( Subject K.D. )

Index of Task Difficulty - Radians/sec.

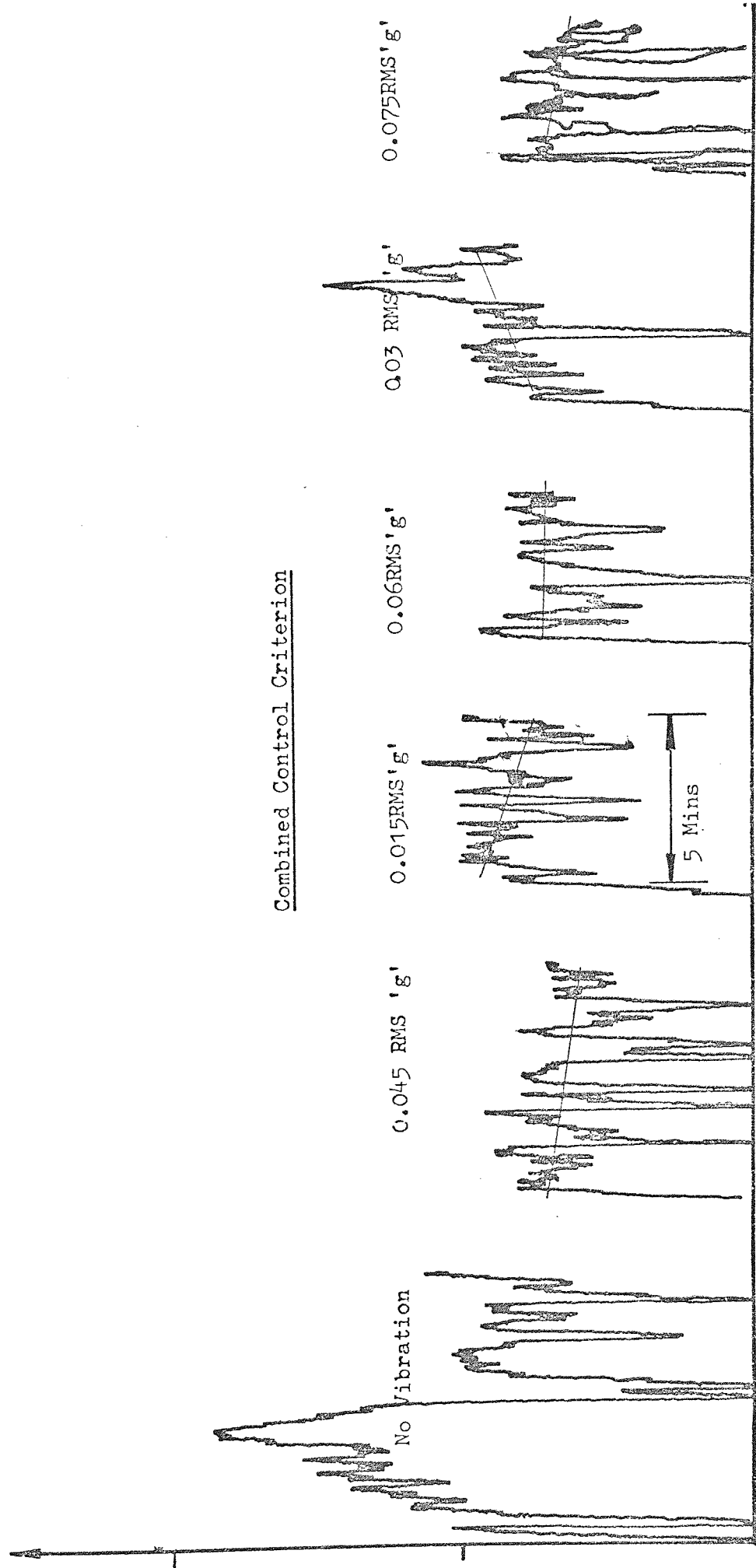

with stationary vibration is shown in Fig. 2.43.

The results shown in Fig. 2.38 have been plotted in rank order according to the time it took subjects to stabilise their task difficulty score in training, so that subject T.H., a test pilot who stabilised within the first 30 minutes of practice was ranked first and subject R.M. a fashion model who took seven trials lasting a total of 210 minutes was ranked last,

Fig. 2.44 is the result for each condition shown in Fig. 2.38 averaged across subjects. Not all subjects were tested at levels above 0.06 Rms'g'. The numbers contributing to the average values have been marked in the figures where appropriate. The effect of this has been to introduce a bias into the results because those tested above 0.06 Rms'g' when averaged were the more able in the group so that the change in slopes at 0.06 Rms'g' is an artifact of the average and should not be interpreted as a change in sensitivity to vibration.

#### 2.6.7. Group average results.

The average values shown in Fig. 2.44 indicate up to an intensity of 0.09 Rms'g' that :

(a) Vertical random vibration caused an increase in task difficulty at a rate roughly in linear proportion to Rms'g' intensity.

(b) The rate of increased difficulty was dependent upon the control criterion . When the compensatory tracking criterion was used (condition A) the nature of the task was such that difficulty increased at a rate of 25 rads/sec/'g'. The instruction to keep the line on the scope (condition B)

Results of Experiment I - Group Averages

Figure 2.44

Index of  
Task Difficulty

'A'- Expt.cond.'A'-Non-Stationary Vibration  
'B'- Expt.cond.'B' " " "  
'C'- Expt.cond.'C' " " "  
'D'- Expt.cond.'D' Stationary Vibration

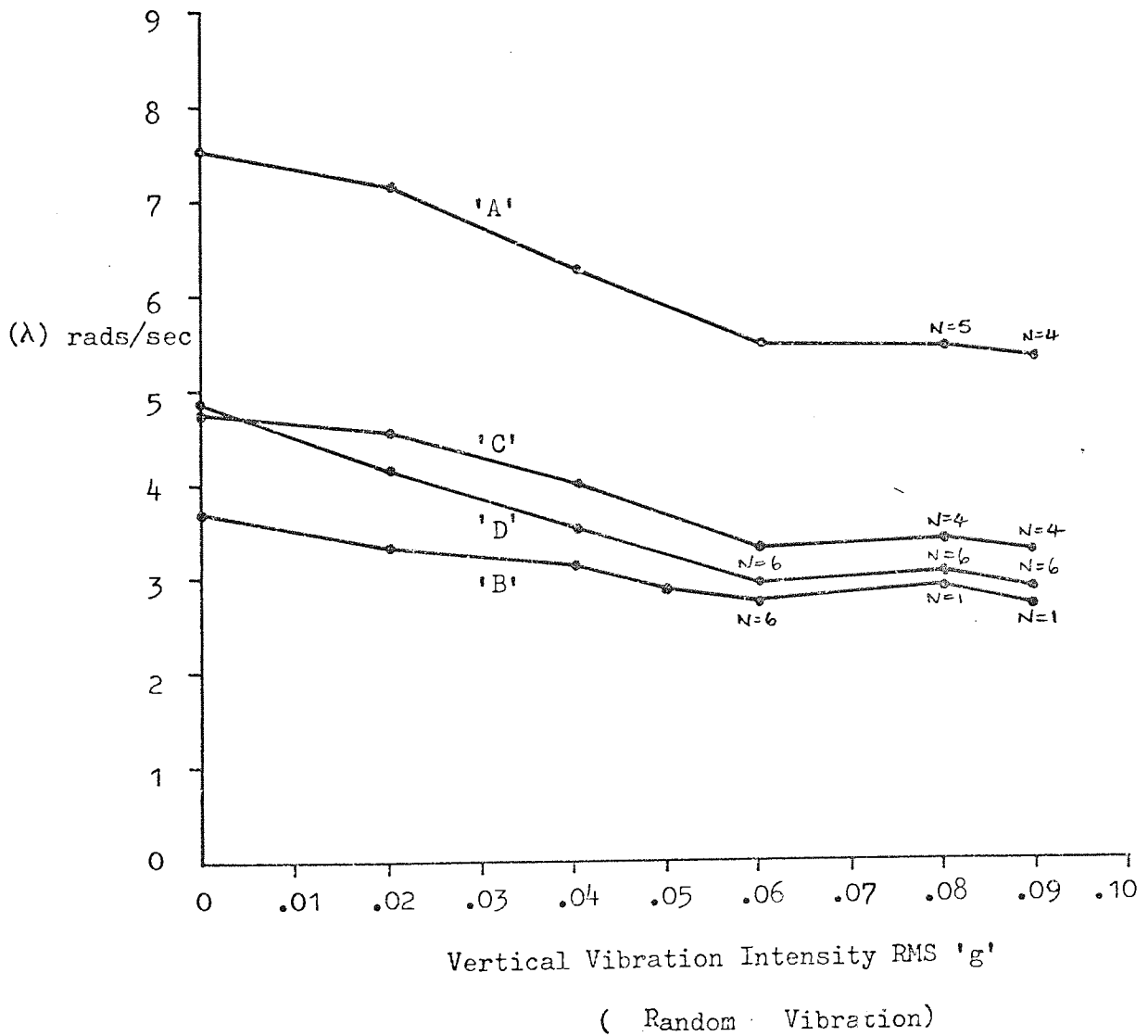

and the combined criterion used in conditions C and D all resulted in a rate of increase of approx. 14.5rads/sec/'g'.

(c) Stationary random vibration, condition D was no different in its effect upon task difficulty than non-stationary vibration, condition C.

(d) The control criterion which encouraged bang-bang control action appears to have double the effect upon task difficulty. This effect however is an artifact of the adaptive logic and performance measure and must not be interpreted as such. The adaptive logic was set up to adapt the task to mean error modulus and not to the number of times the subject allowed the line to exceed the margins of the scope. The logic was thus appropriate to performance under condition A but not B,C and D, meaning that the results shown in Fig. 2.38 and 2.44 for B,C and D do not fully reflect the control success of subjects. Thus it is not possible to make valid comparison between A and the results for the other conditions.

(e) The effective time delay  $\tau_e$  implied by the adaptive variable increased by 0.054secs. under condition A from 0.1335 to 0.188 secs..

#### 2.6.8. Individual results.

The individual results in Fig. 2.38 reveal that :

(a) Despite training subjects not experienced in coping with vibration were unable to match the performance of the professional controller. At 0.09 Rms'g' unskilled subjects K.D., R.M. and D.H. found the task more than twice as difficult as the professional, T.H., as indicated by the index of difficulty.

(b) No improvement in performance resulted from vibration and after effects were a mixture of improvement and decrement.

(c) The hysteresis effect produced by the non-stationary vibration

conditions A, B and C, was largest for the female subjects K.D. and R.M. For the remaining subjects there was no consistent pattern of response between rising and falling intensity either within subjects, between subjects or between instructions.

(d) The oldest subject in the group performed least well on condition A and B and was the operator whose performance on A was most effected by vibration. This cannot, however, be taken as evidence of an age effect and neither can the performance of the female subjects be taken as evidence of a sex effect because both factors are inseparable from the skill factor.

#### 2.6.9. Data analysis.

A battery of waveform analyses were carried out on the raw data records each of which was 30mins. in length. The analyses were carried out in an attempt to further explain the findings on the effects of vibration, to provide more insight into the nature of manual control skill and to look for differences in meaning and utility between alternative methods of analysis.

#### 2.6.10. Analysis of ECG records.

The number of heart beats was electronically counted in contiguous/minute intervals to give a measure of heart rate.

#### 2.6.11. Analysis of task and vibration data.

For the task data the analysis epoch was 200 seconds, an interval which was dictated by the Auto and Crosscorrelation requirement that the sample be ten times the maximum time displacement. The analyses or descriptions

Heart Rate Within and Between Trials

FIGURE 2.45

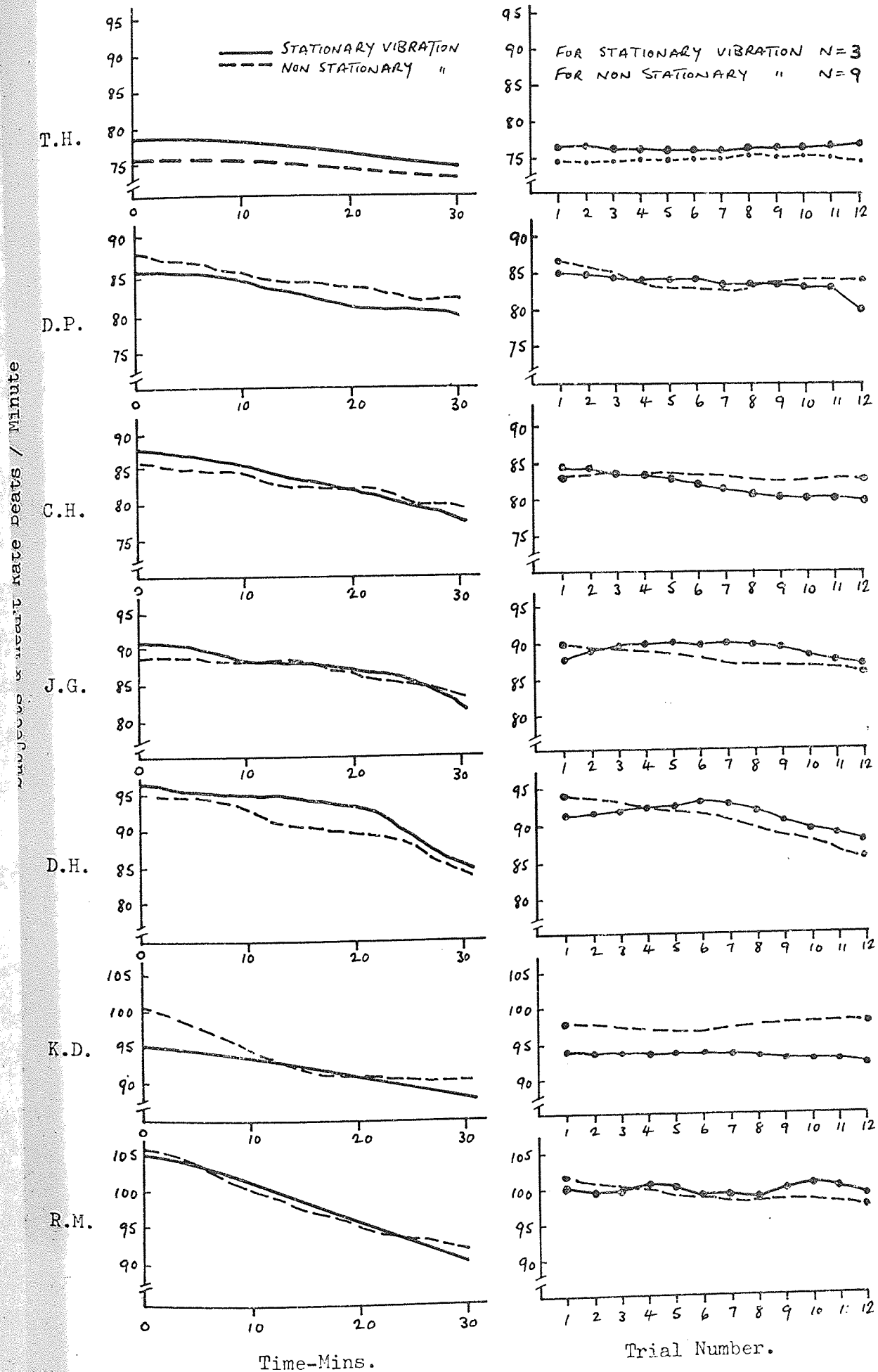

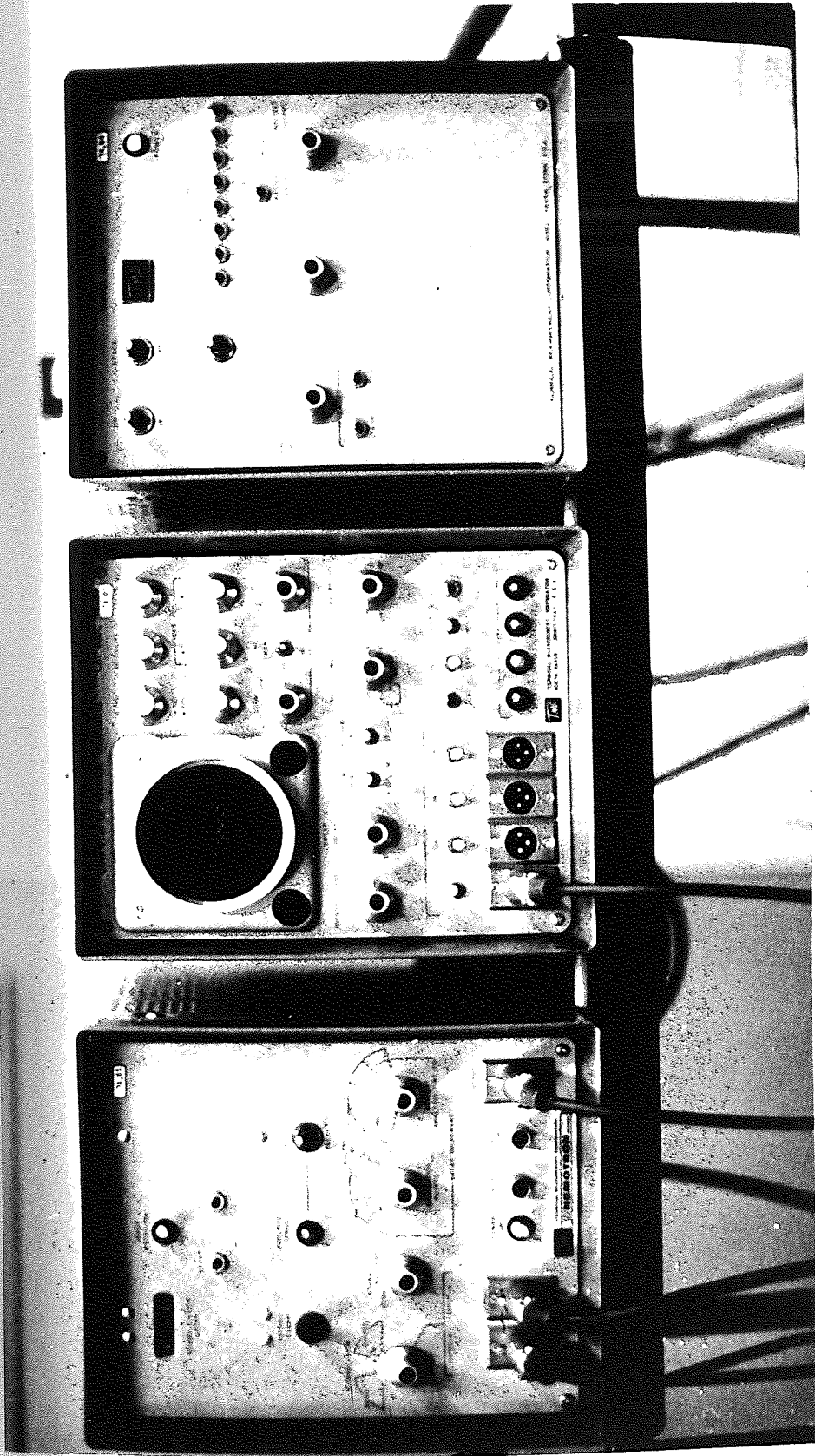

Photograph 9.

Correlation computer and tape punch unit.

applied to the task data included Amplitude Probability, Zero Crossing, Linear and Non Linear Cross Spectrum, correlation and phase plane analysis. The same battery was applied to vibration except that the analysis interval was 5 minutes and phase plane was omitted.

The amplitude, correlation and zero crossing analysis were all done on the TMC-CAT/COR Computer. Analog spectrum analysis was done on the Spectral Dynamics Corp. Analyser. For cross spectrum and phase plane analysis special programs were written in Algol 60 for the ICL 1905 Computer and are included in Appendix B. . The analog spectrum analysis facility and CAT/COR computer are shown in Photograph 12. The CAT/COR system is on the right of the picture.

#### 2.6.12. The Results of Analysis.

##### 2.6.12.1. Heart rate.

Mean heart rate for each subject within and between trials is shown in Fig.2.45. The graphs shown have been plotted from top to bottom in order of time taken to stabilise on the adaptive task during training. It is evident from the figure that mean rate is influenced by experience of control during vibration, by time on the task and to some extent by the number of trials. Over trials the heart rate for the least and most skilled subjects appears stationary, an effect which suggests full adaptation for the skilled subject but failure of the unskilled to psychologically settle to the vibration. There was no difference in mean heart rates between stationary and non-stationary vibration and no consistent effects due to the onset of vibration either within or between subjects.



( Condition 'B' subject TH )

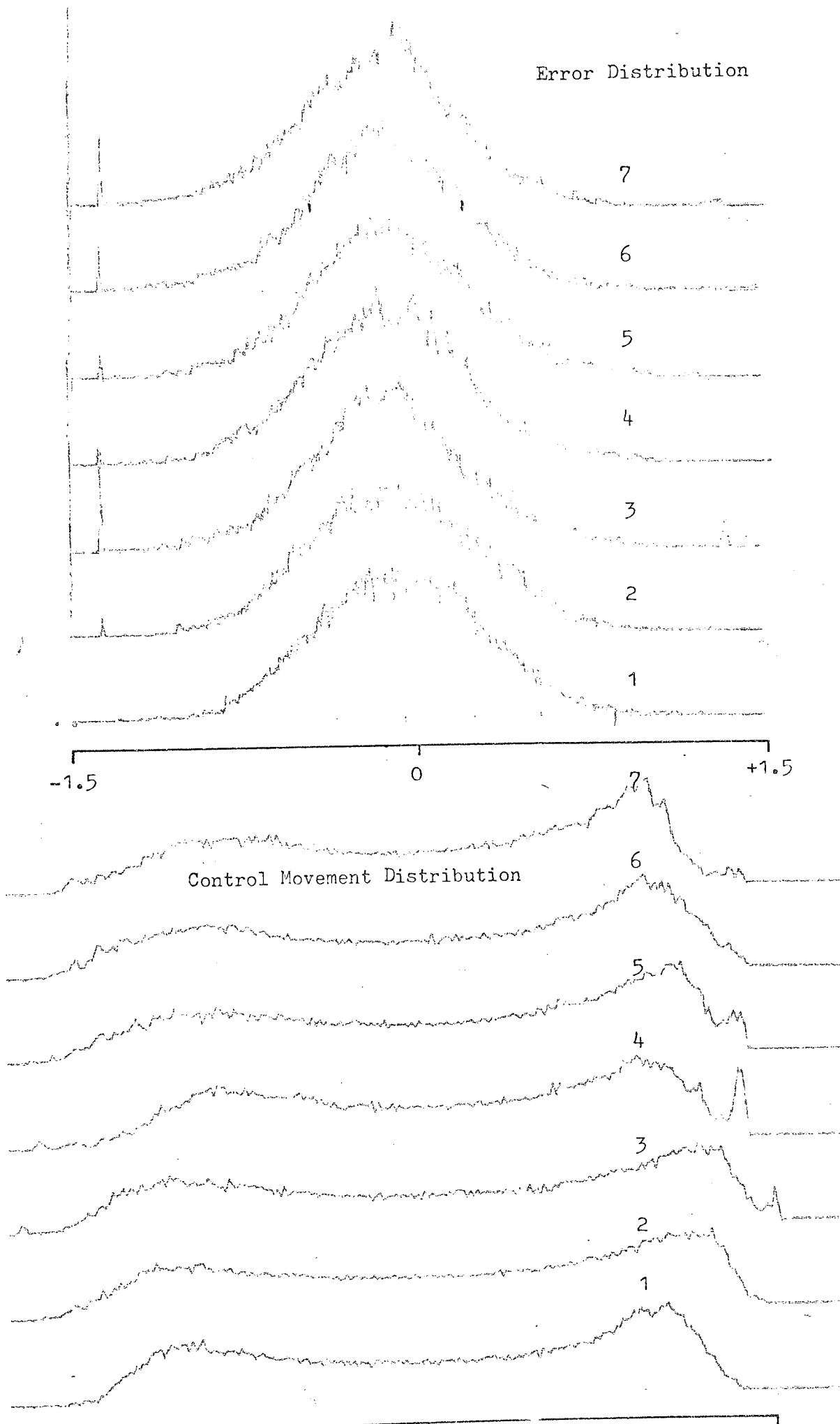

Probability Distribution of Task Difficulty  
showing the Associated Intensity of Vibration  
(condition 'B' subject TH )

Figure 2.47

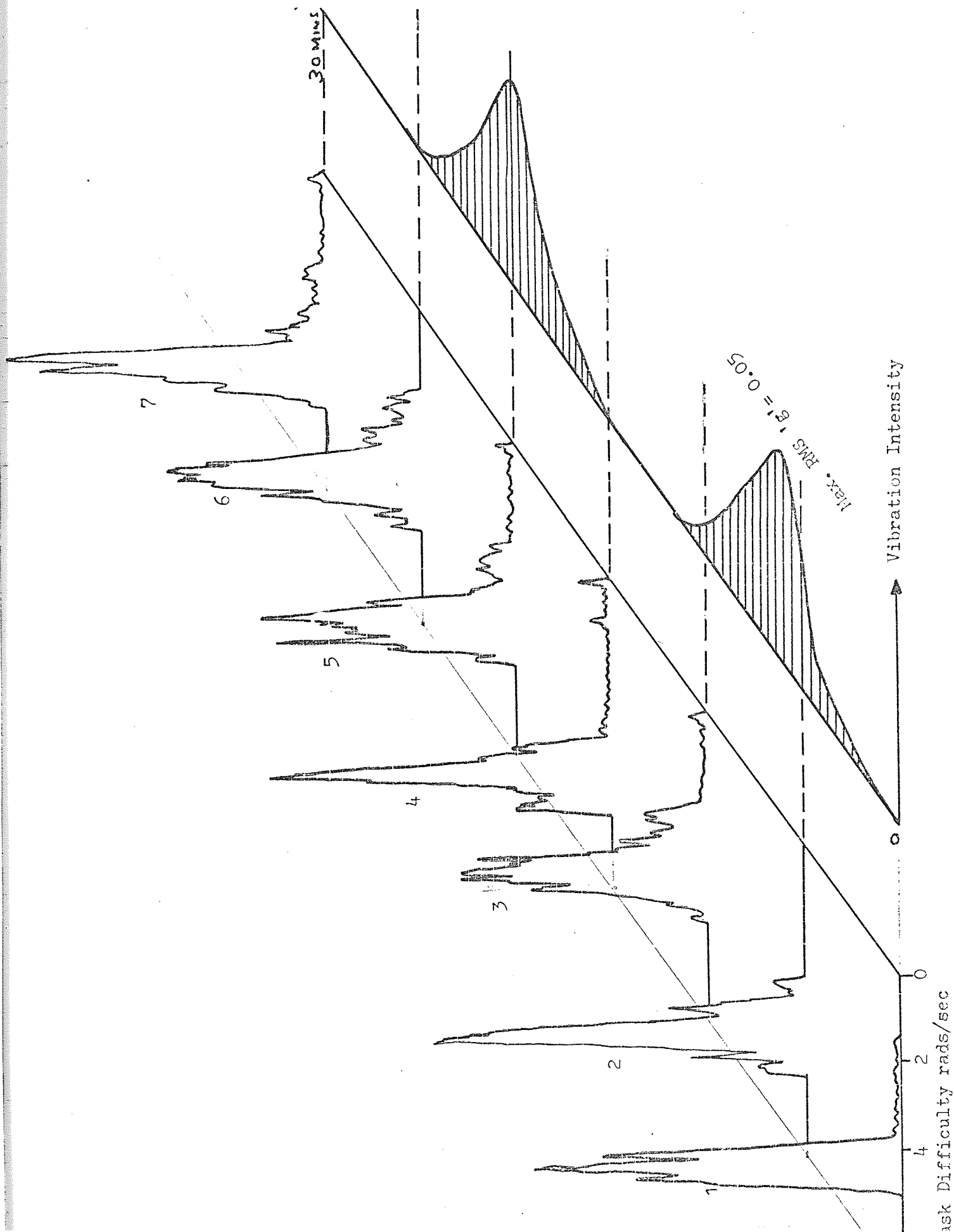

## 2.6.12.2. Task variables.

### Amplitude analysis.

Amplitude probability density profiles for the input, displayed error signal, operator control action and the index of task difficulty for one subject over one trial under condition B are shown in Figs. 2.46 and 2.47. The trial was that shown in Fig. 2.39. The subject was the most skilled in the group and he was using a bang-bang control policy. Note that the distribution of error and control actions bears no relation whatever to the distribution of the command signal in Fig. 2.27. His control actions approximate to a sinusoidal distribution and distribution of error to a Gaussian distribution. The distribution of error indicates that the subject was successful in keeping the line on the oscilloscope for nearly 100% of time and that for 99.74% of the time the line was within  $\pm 1.0$  inch deviation from the target centre line, but remember that this was partly due to the automatic control exercised by the adaptive task whose criterion was  $\pm 0.5$  inches. The fact that error was not contained within this margin was due to the rather slow adaptive rate or response speed of the control system to changes in mean error modulus error. The ratio of error in the tails of the distribution either side of  $\pm 0.5$  in. to the error under the curve between  $\pm 0.5$  in. provides a measure of the feedback inherent in the task. For this type of control policy and adaptive rate only 10% of the movement displayed provided experience outside the control loop from which the subject could glean a measure of his attainment.

The distributions of task difficulty show that the subject was less consistent in his behaviour during vibration. Further examples of amplitude

Zero Crossing Analysis.

Subject TH.

Control Actions.

Vertical Scale 1 inch approx 10 crossings

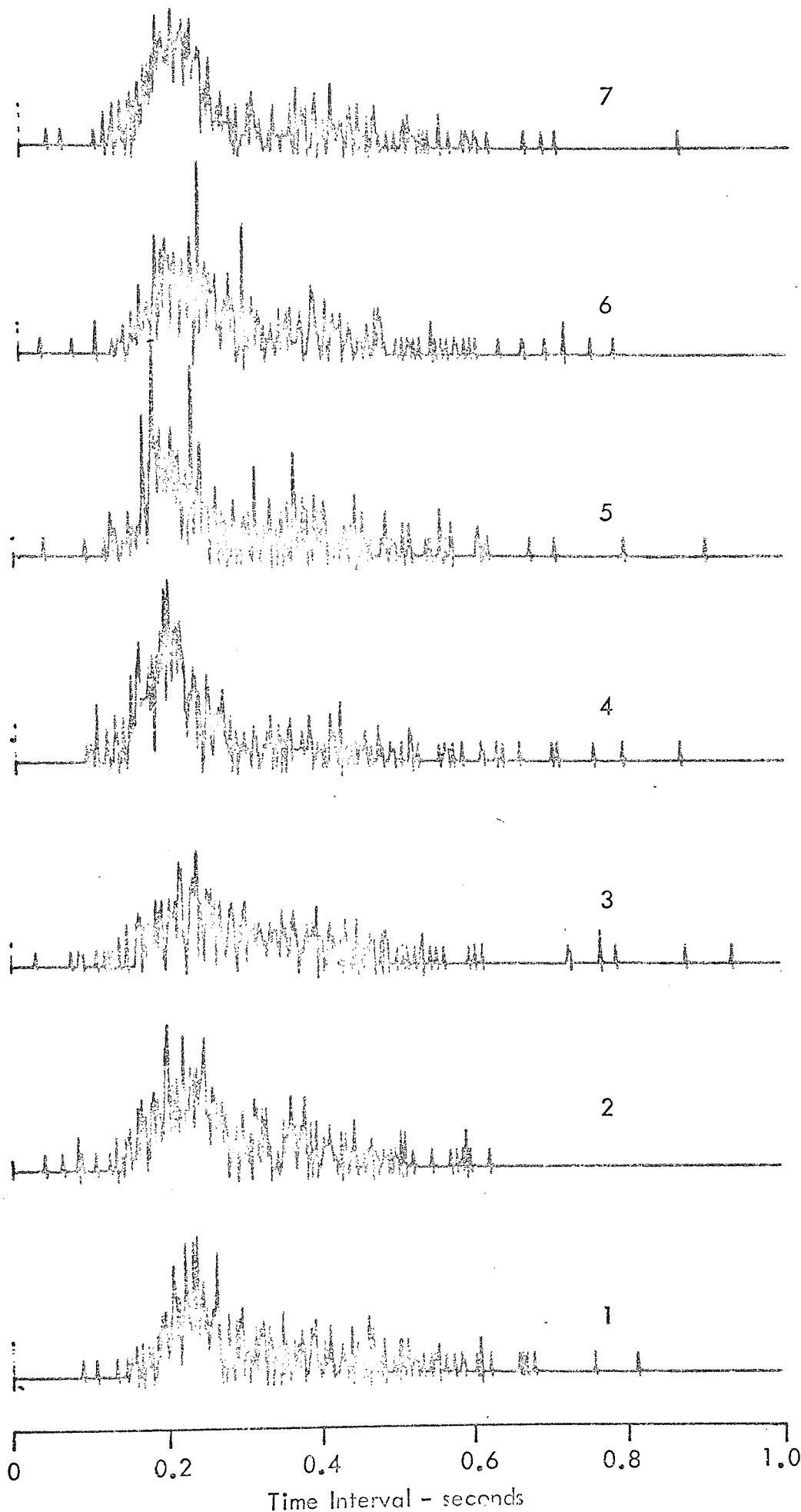

FIGURE 2.49

Zero Crossing Analysis.

Subject KD.

Control Actions.

Vertical Scale 1 inch approx 10 crossings

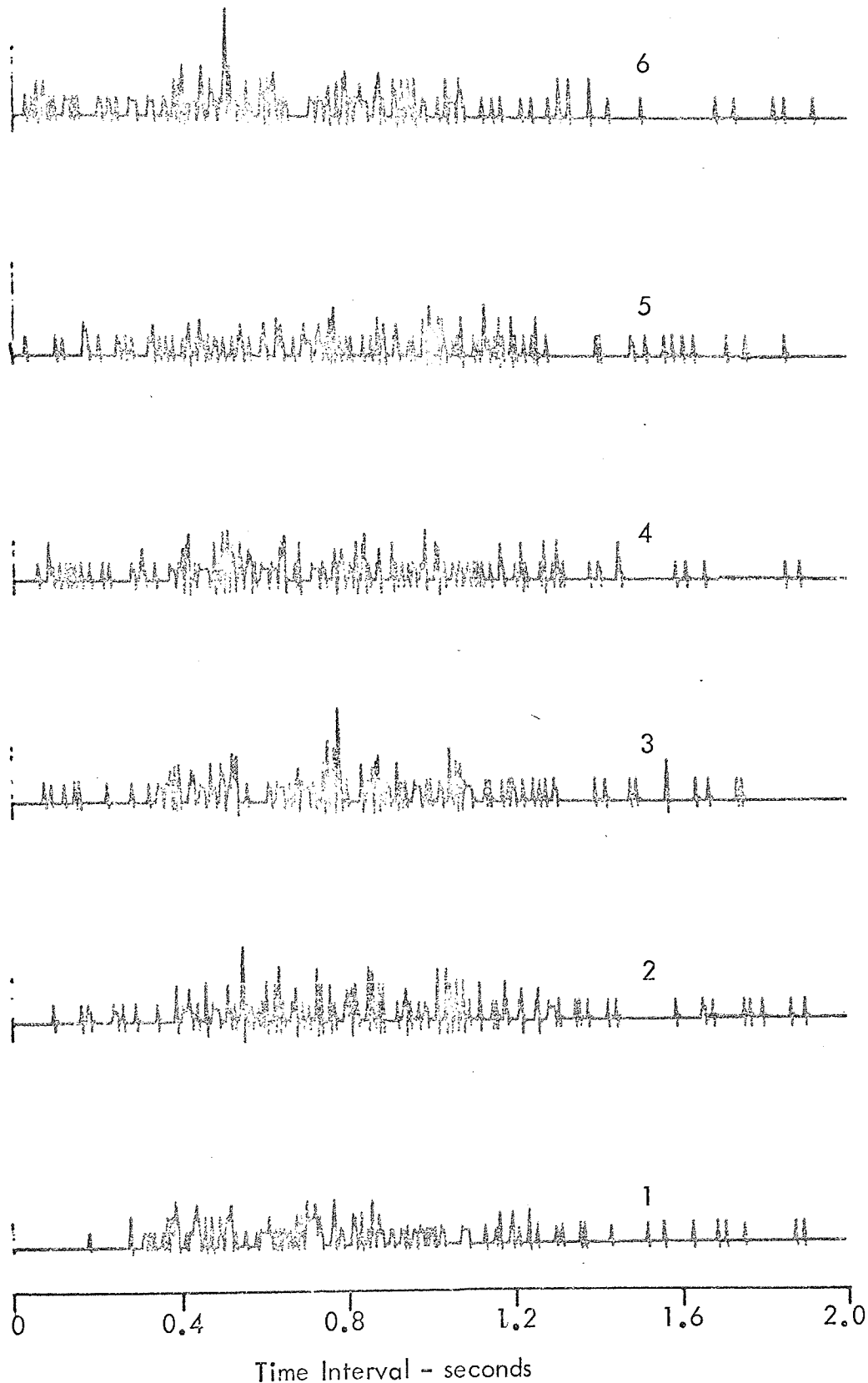

analysis are given in Experiment III where development of the bang-bang policy is shown to occur.

#### Zero Crossing Analysis.

Time interval histograms of zero crossings for control actions are shown in Figs. 2.48 and 2.49. The subjects are T.H. and K.D. and the zero crossings relate to the trials shown in Figs. 2.39 and 2.42 respectively. Subject K.D. was using the combined control objective and T.H. bang-bang action as before. Despite the instruction to 'keep the line on the scope' as well as minimise deviation subject K.D. exercised precise tracking control typical of compensatory tracking behaviour. As a result no dominant zero crossing interval emerges and the majority of intervals are above 0.2 secs.. T.H.'s bang-bang control on the other hand emerges as having a dominant crossing interval which got progressively less as he proceeded through the trial indicating increased effort. At the beginning it was 0.23secs., after 30mins. 0.20secs. corresponding to frequencies of movement of 2.17 cycles per sec. and 2.5 cycles per sec.

Subject K.D. too, shows signs of speeding up because there is a general shift to the left with progress through the trial. The effects of non-stationary vibration which is present over histograms 2-3 and 5-6 for T.H. 3-4 and 6-7 for K.D. do not show clearly the effects observed in Figs. 2.39 and 2.42.

#### Correlation - Time Delay Analysis.

Time delays between input command and control movement; input command and

Time Delay Analysis.  
Subject T.H.  
Oscillatory Random Vibration.

Figure 2.50

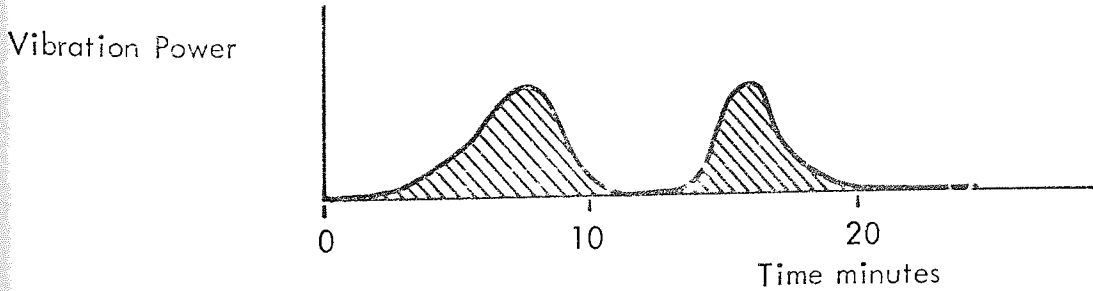
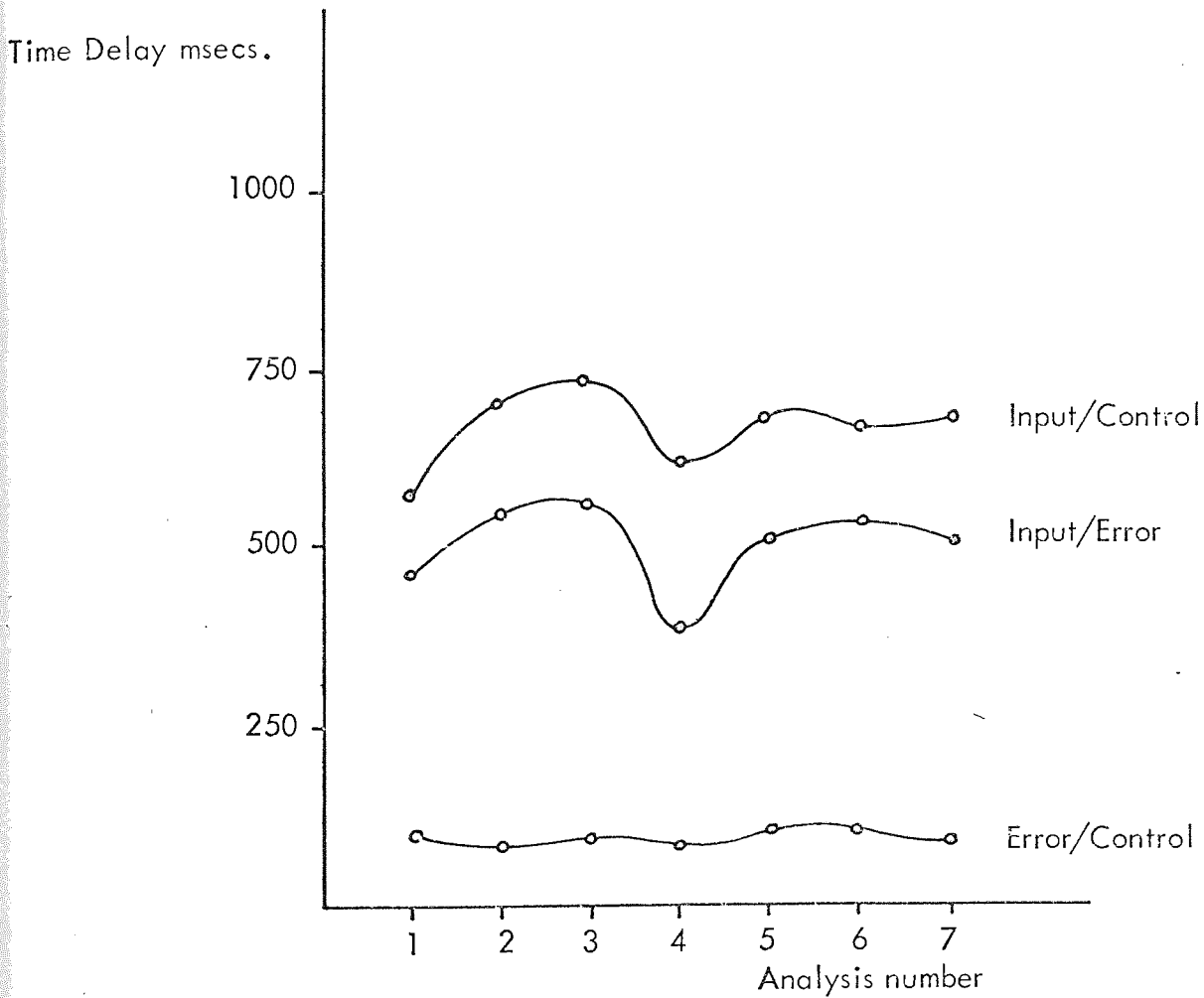
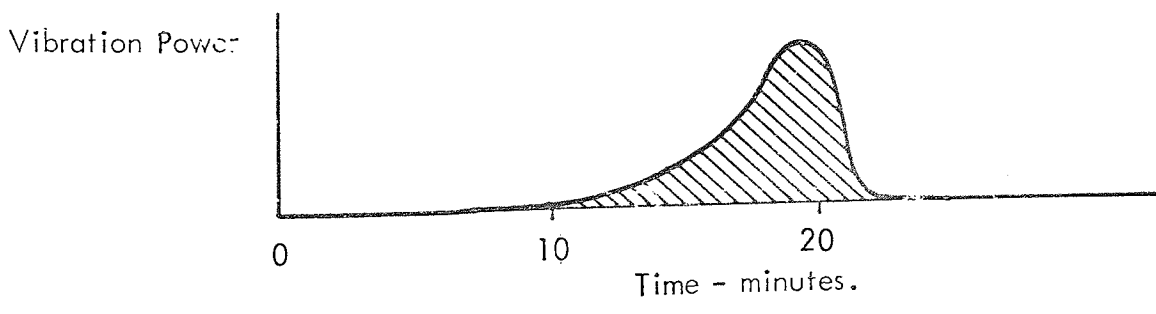
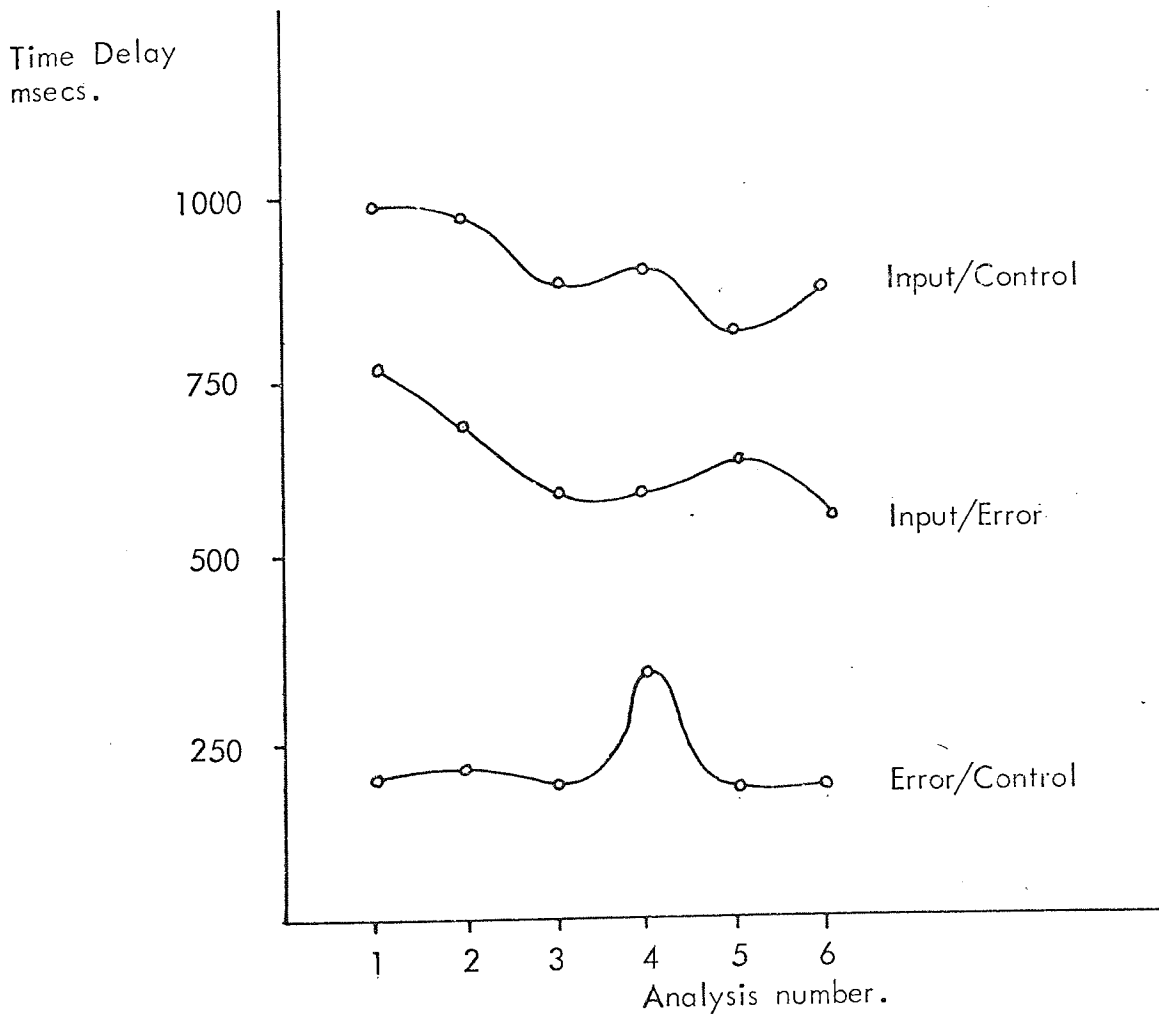

Figure 2.51

Subject D.P.  
Time Delay Analysis.  
Oscillatory Random Vibration.





Time Delay Analysis.

Figure 2.52

Subject R.M.  
Oscillatory Random Vibration.

Time Delay  
(msecs).

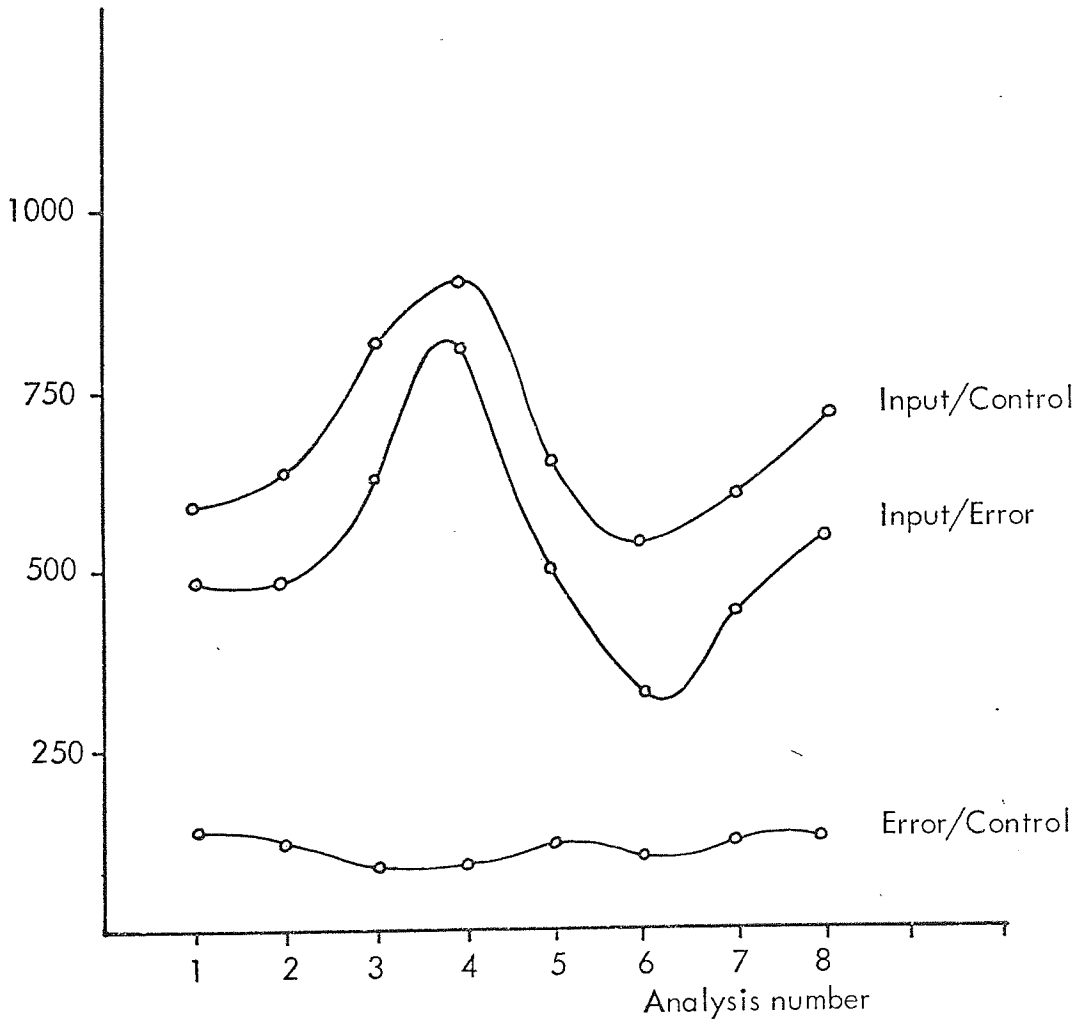

Vibration Power

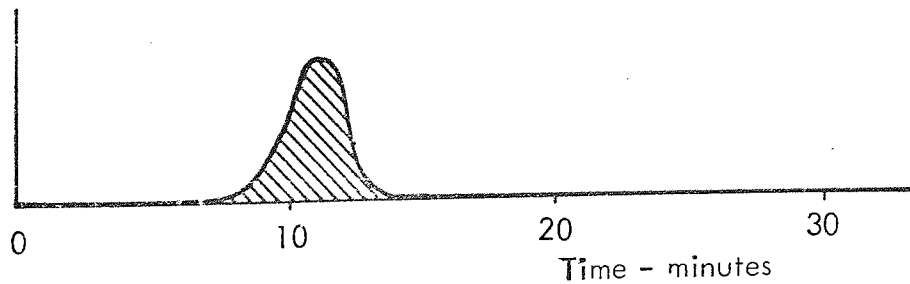

display movement (error) and between display movement and operator control actions are shown in Figs. 2.50, 2.51 and 2.52. The trials to which these refer are shown in Figs. 2.39, 2.40 and 2.41. For each analysis epoch the time delays were obtained from crosscorrelograms between the appropriate task variables. Several auto and crosscorrelograms are shown in Figs. 2.53 to 2.68. The time delay between variables is the time from the zero delay origin to the peak correlation value nearest zero time delay. It was evaluated to an accuracy of 5 milli seconds.

In Figs. 2.50 and 2.52 it is apparent that vibration has had an effect on Input/Error and Input/Control time delay but not Error/Control. These results and that of D.P. where time delays were not effected by vibration are consistent with the effects of vibration on task difficulty shown in Figs. 2.39-2.41. but it is not certain that the changes in time delay which are apparent, explain the changes in task difficulty. There are discrepancies. For example the task difficulty index in Fig. 2.39 implies that subject T.H. was operating with an effective time delay of 230m.secs. without vibration and about 357m.secs. at the peak of vibration whilst the error/control delay in Fig.2.50 which is equivalent to the effective time delay  $\tau_e$  indicate a delay of 100m.secs.. This discrepancy is due to the control criterion effect described earlier which falsifies the index of difficulty when bang-bang control is adopted. Subject R.M. whose control actions were more akin to compensatory tracking behaviour recorded an index of difficulty without vibration of about 7.6rads/sec. giving an effective time delay of 130m.secs. a figure which agrees with the error/control time delay in Fig.2.52. The other odd result, which is more difficult to explain, is that vibration appears to effect response time to the input command signal but not response time to the displayed error signal. The error signal as seen by the operator is the difference between the command signal and the state of the controlled

element. By deliberately forcing the controlled element into a high amplitude controlled oscillation at a frequency above the highest in the command signal the operator is modulating or masking the command with a signal which he can predict and whose direction he switches at the right time to prevent the line moving off the screen, making little or no attempt to cancel the command signal. With vibration it is possible that the operator pays even less attention to the command signal because he probably has to concentrate harder on generating his own. Also it is likely that vibration interferes with switching accuracy to an extent which causes the operator to take less account of what the command was saying. Subject R.M. paradoxically reduced her response time to displayed error slightly during vibration but at the same time increased her reaction time to the command signal. During vibration this subject, in spite of instructions to the contrary, lapsed into bang-bang control so that a part of her decrement in difficulty is attributable to the error concomitant with bang-bang control.

#### Spectrum Analysis.

Auto and Cross Power Spectral Density Analysis were carried out for each of the four trials in Figs. 2.39-2.42. From these, certain spectral ratios were calculated between the input, error and control action waveforms in order to describe the information processing behaviour and linearity of the human operators. For each 200 second analysis epoch the following spectral densities were calculated :

- |     |                              |          |
|-----|------------------------------|----------|
| (a) | Input Auto Spectrum          | $G_{ii}$ |
| (b) | Error Auto Spectrum          | $G_{ee}$ |
| (c) | Control Auto Spectrum        | $G_{cc}$ |
| (d) | Error-Control Cross Spectrum | $G_{ec}$ |

# FOURIER/MILNER TRANSFORM

G.D. WHITEHEAD

Figure 2.53

Analysis of Task Input  
signal -  $R_{ii}$  and  $G_{ii}$ .

$R(0) = 0.569486E 05$

$R(INF) = 0.543414E 05$

AUTOCORRELATION COEFFICIENT

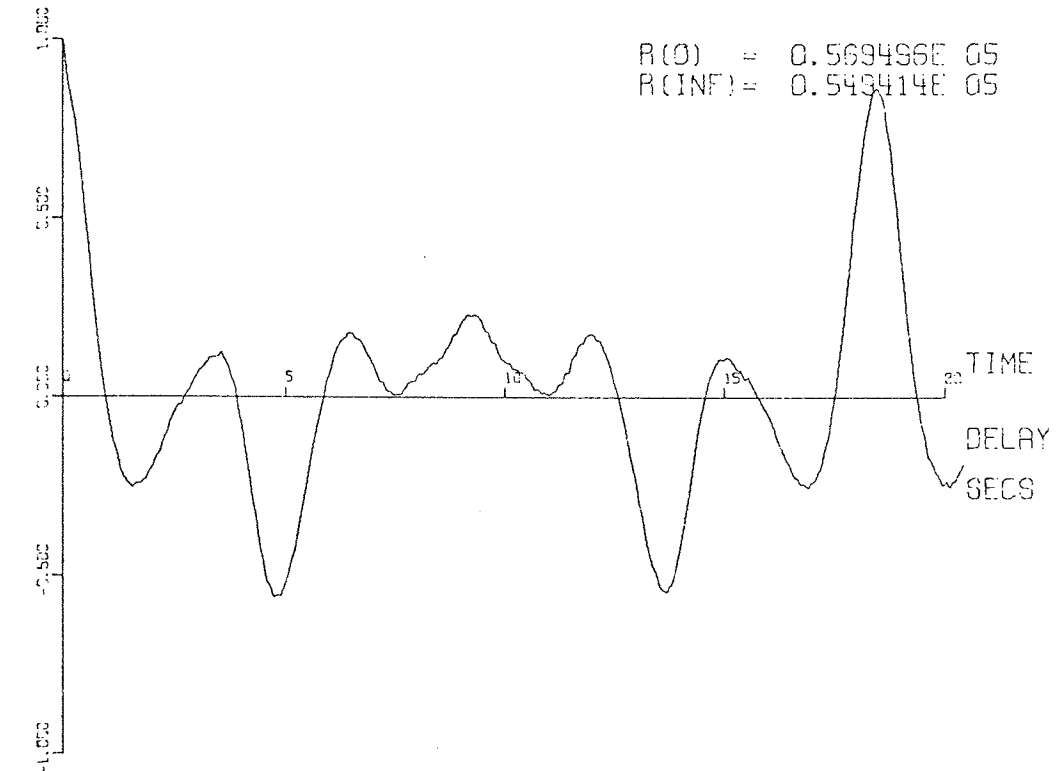

POWER SPECTRAL DENSITY

CM. CM/RAD/SEC

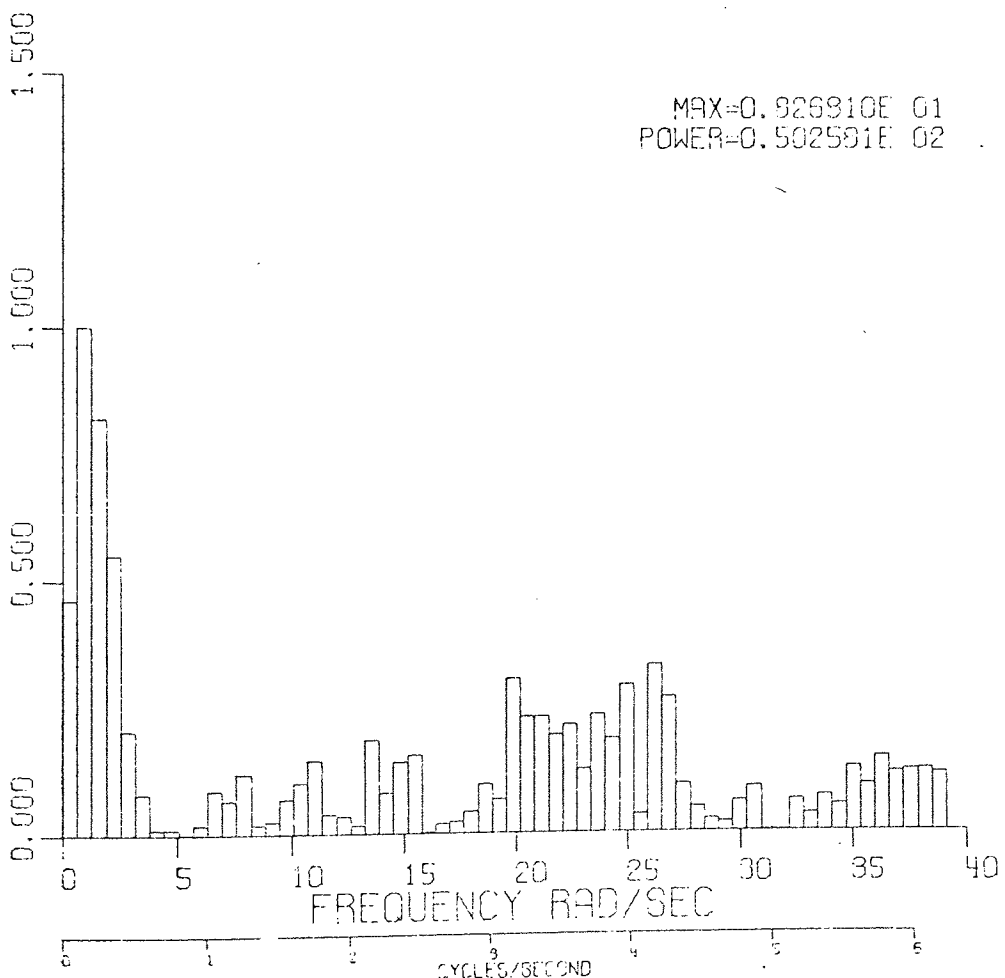

MAX=0.926910E 01  
POWER=0.502501E 02

# FOURIER/MILNER TRANSFORM

G.D. WHITEHEAD

Figure 2.54

Analysis of Error Signal

$R_{ee}$  and  $G_{ee}$ .

$R(0) = 0.544320E 05$   
 $R(INF) = 0.533923E 05$

AUTOCORRELATION COEFFICIENT

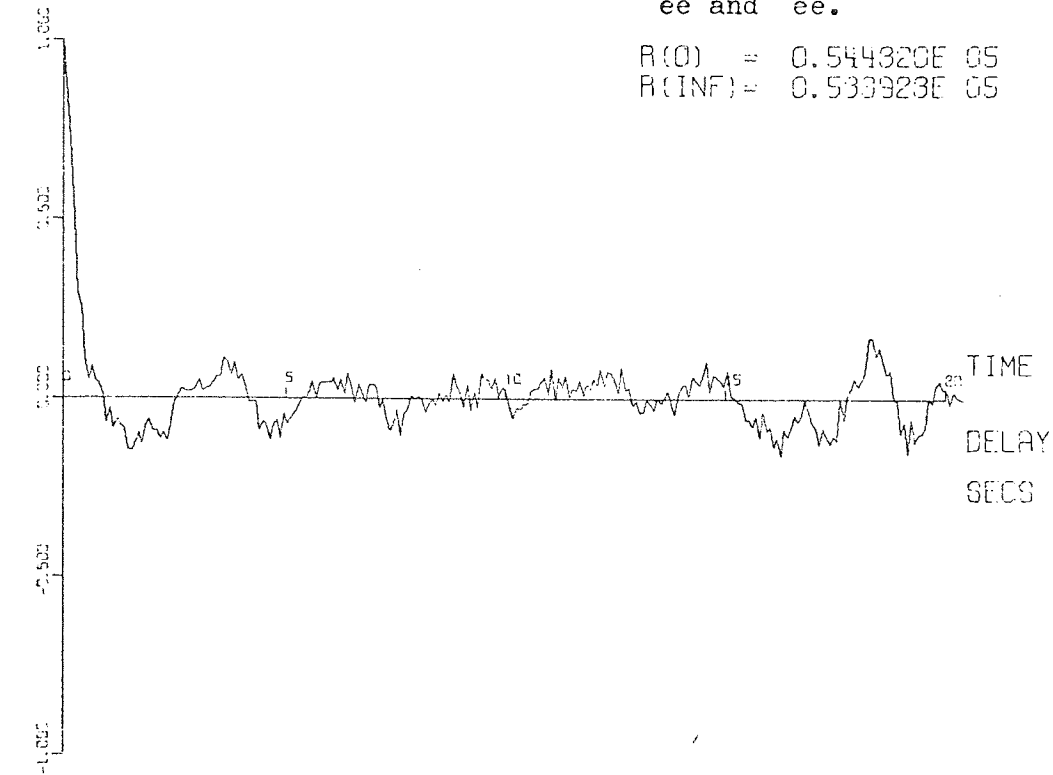

POWER SPECTRAL DENSITY

CM. CM/RAD/SEC

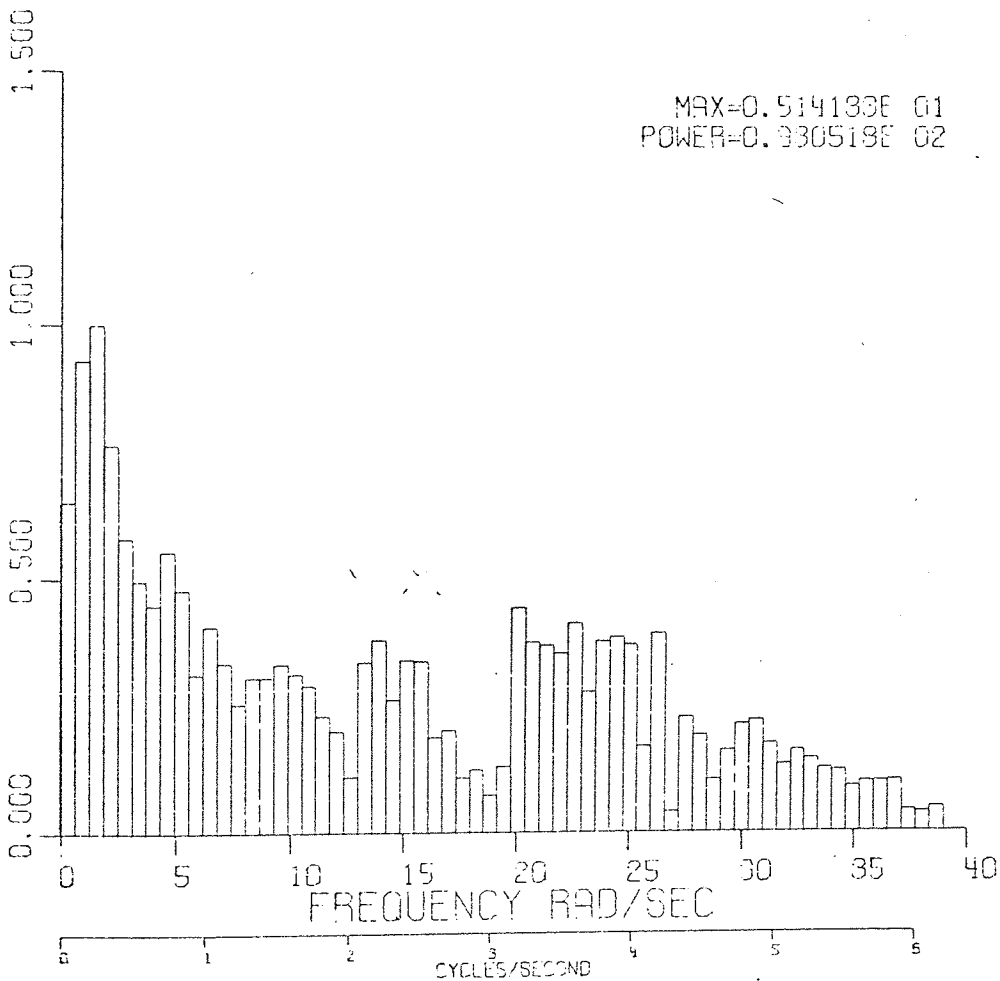

MAX=0.514133E 01  
POWER=0.330518E 02

# FOURIER/MILNER TRANSFORM

G.D. WHITEHEAD

Figure 2.55

Analysis of Control  
movements  $R_{cc}$  and  $G_{cc}$ .

$R(0) = 0.955750E 05$   
 $R(INF) = 0.504461E 05$

AUTOCORRELATION COEFFICIENT

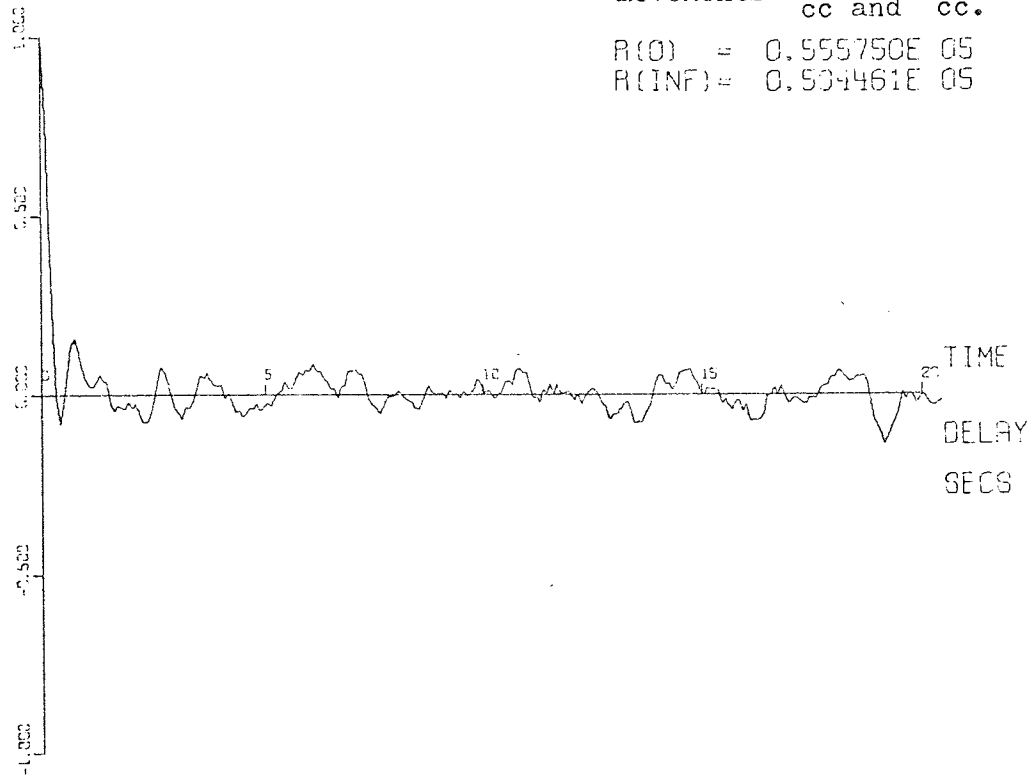

POWER SPECTRAL DENSITY

CM. CM/RAD/SEC

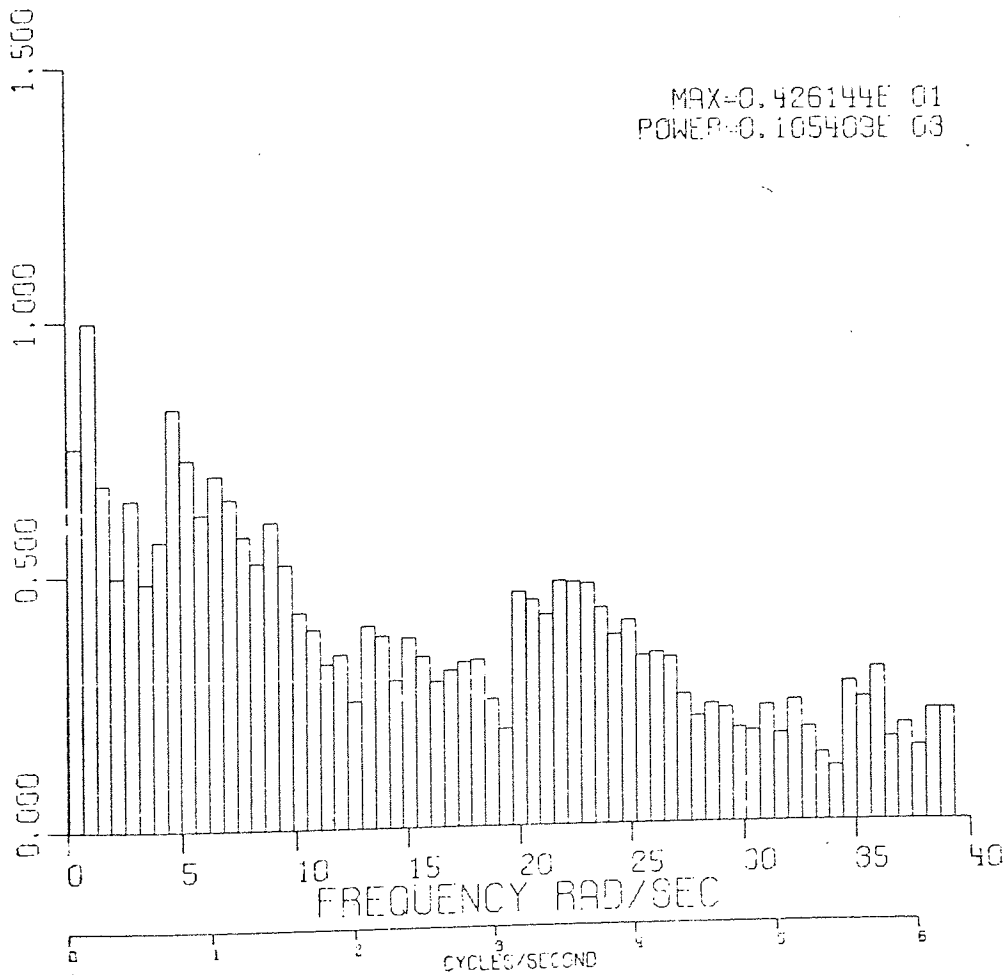

MAX=0.426144E 01  
POWER=0.105403E 03

FOURIER/MILNER CROSS  
SPECTRAL DENSITY ANALYSIS

G.D. WHITEHEAD

Figure 2.56

Analysis Between Error &  
Control Movement signals  
 $C_{ec}$  and  $\dot{Q}_{ec}$ .

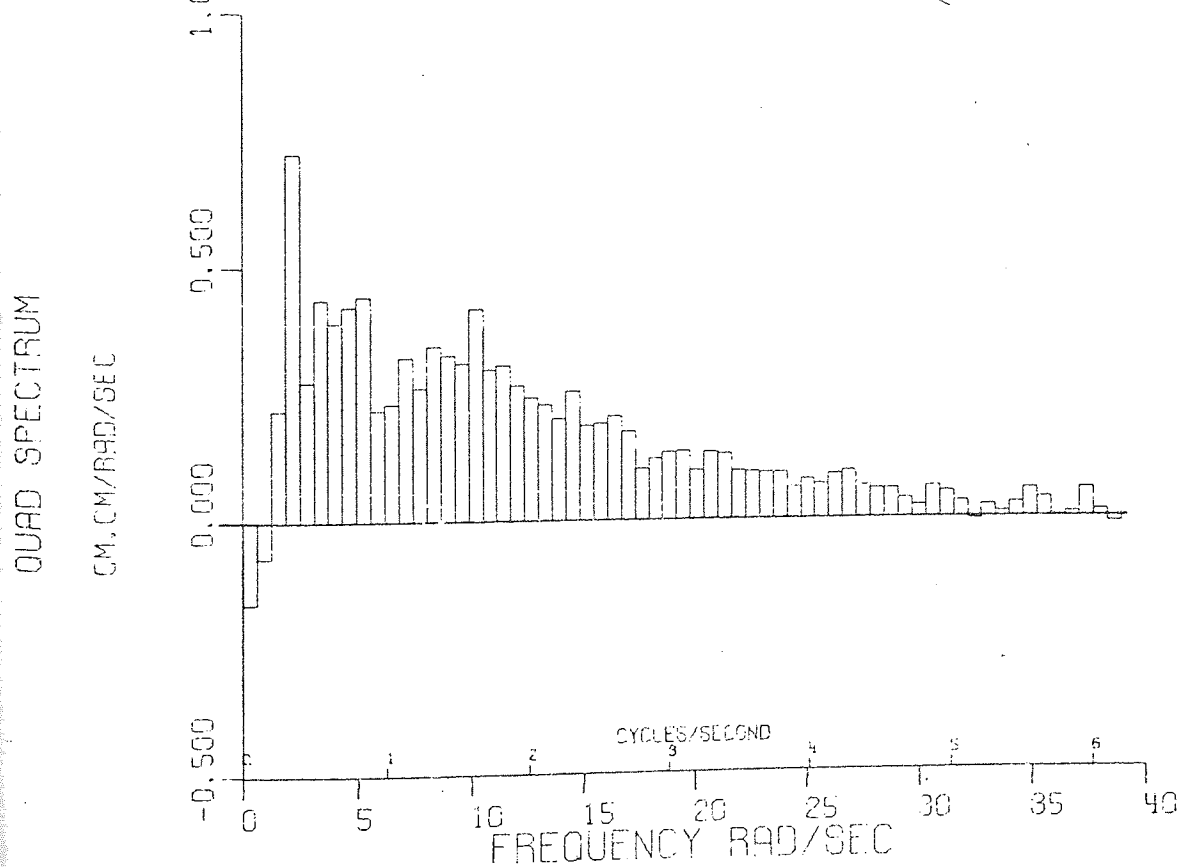
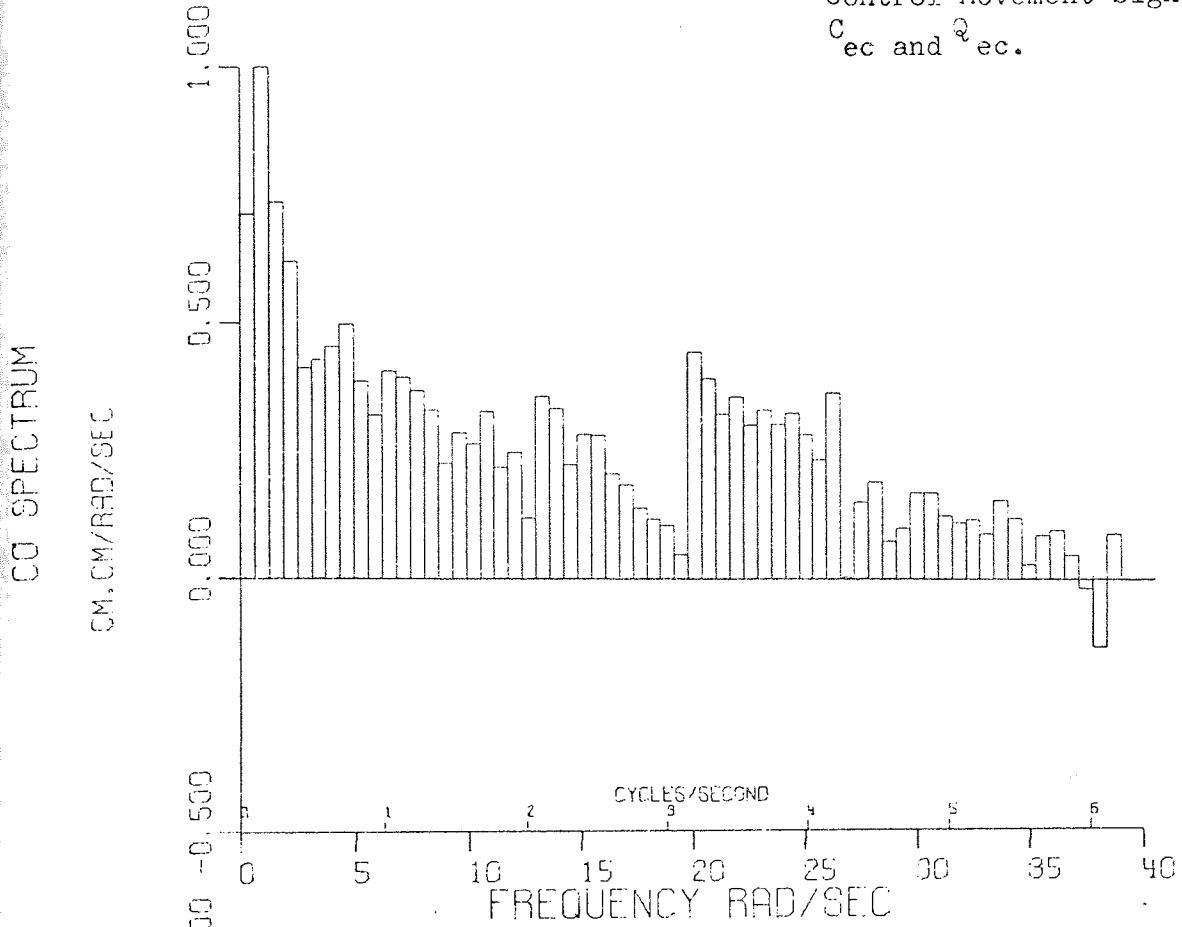

FOURIER/MILNER CROSS  
SPECTRAL DENSITY ANALYSIS

G.D. WHITEHEAD

MAX= 0.556302E 01

Figure 2.57

Crosscorrelation  $R_{ec}$  and  
Kennedy-Pancu Plot of  $C_{ec}$   
against  $Q_{ec}$ .

CROSSCORRELATION COEFFICIENT

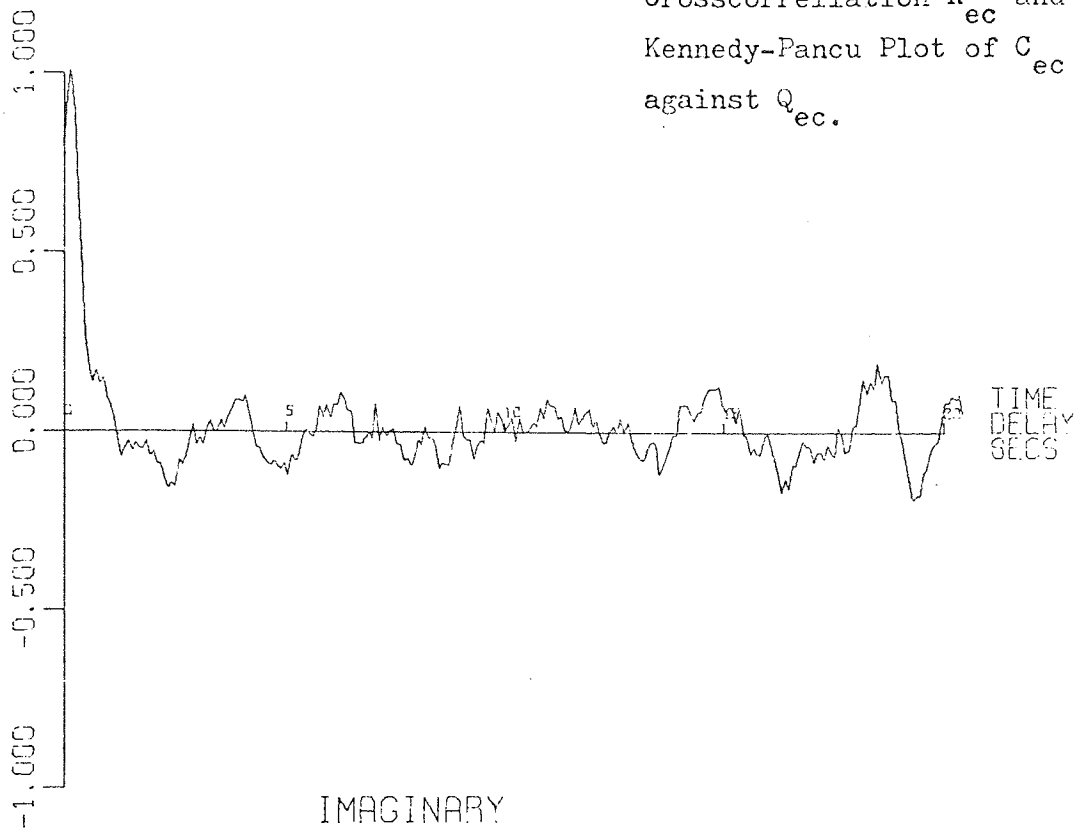

IMAGINARY

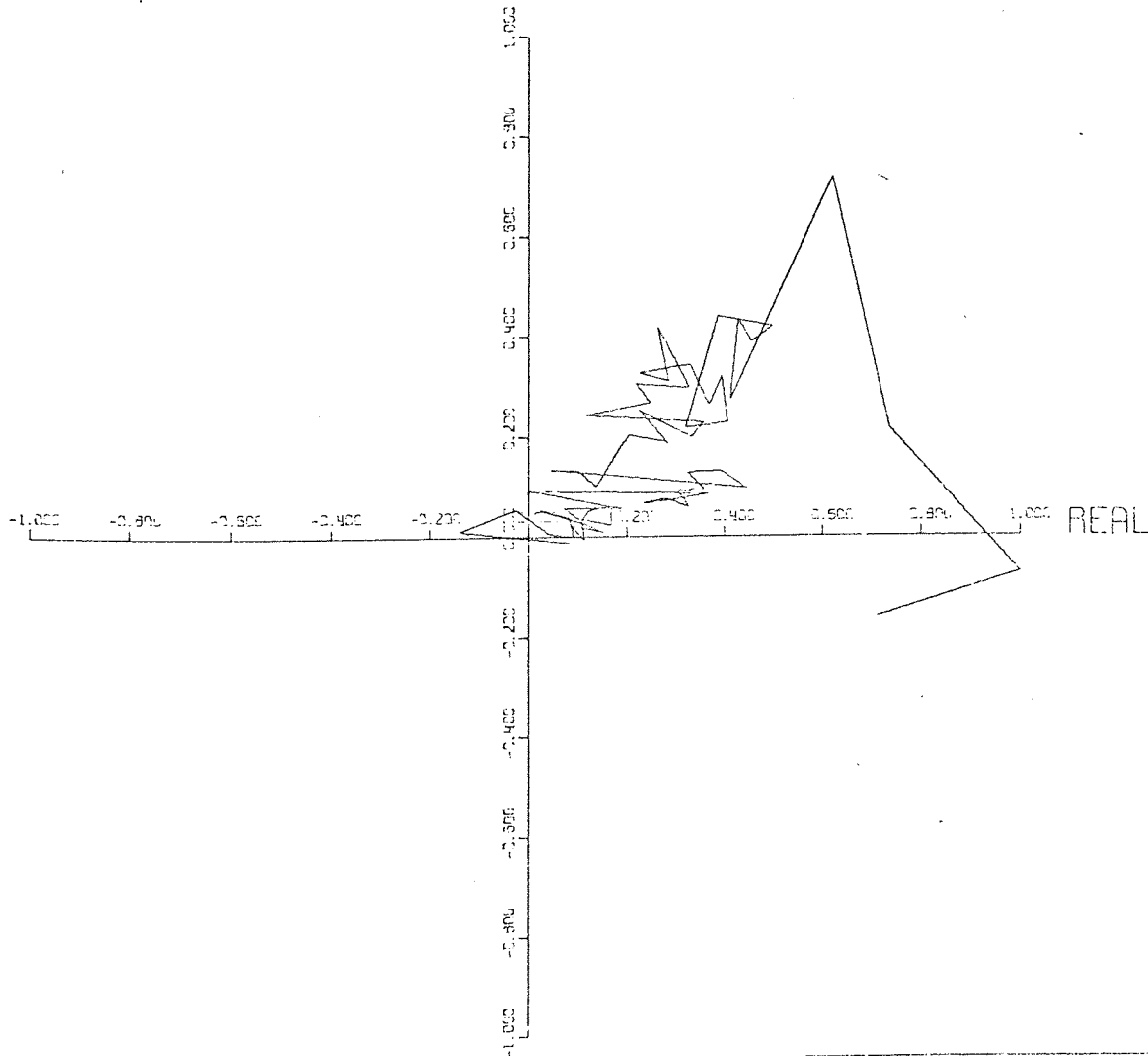



# FOURIER/MILNER CROSS SPECTRAL DENSITY ANALYSIS

G. D. WHITEHEAD

Figure 2.58

Gain & Phase Spectrums between  
Error & Control Waveforms  
based on the ratio  $G_{ec}/G_{ee}$ ,

GAIN-DECIBELS

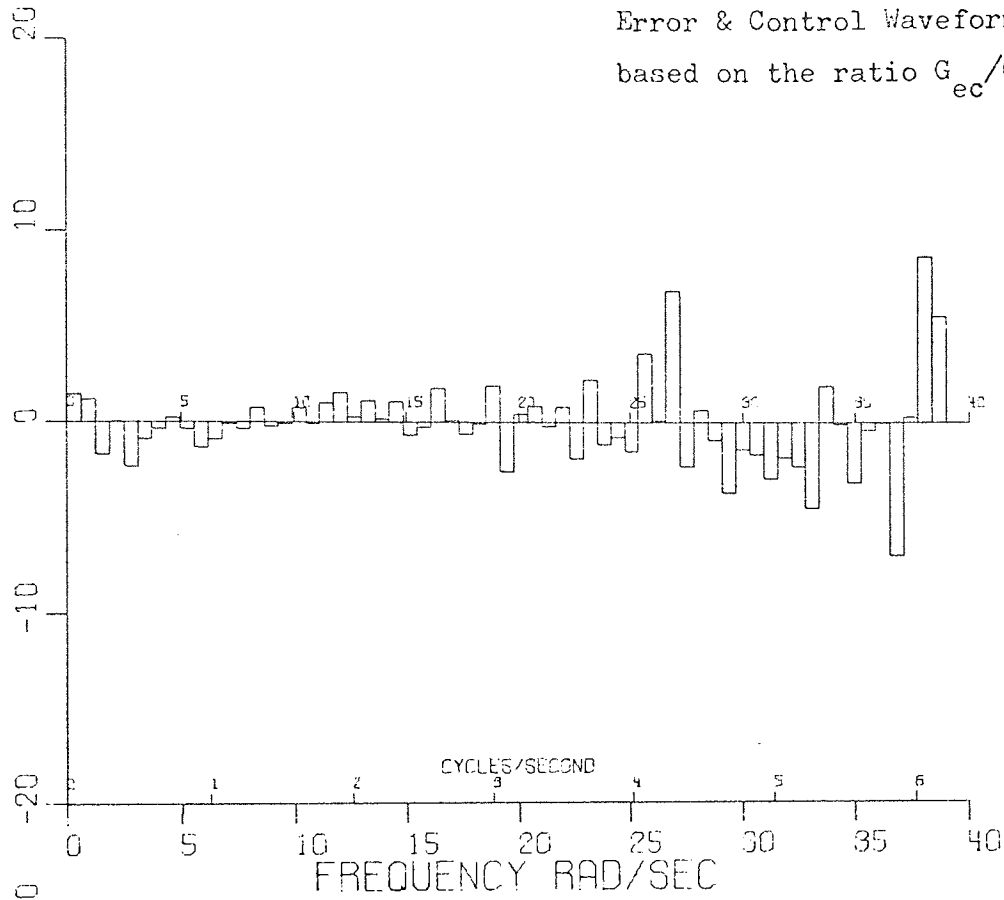

PHASE ANGLE - DEGREES

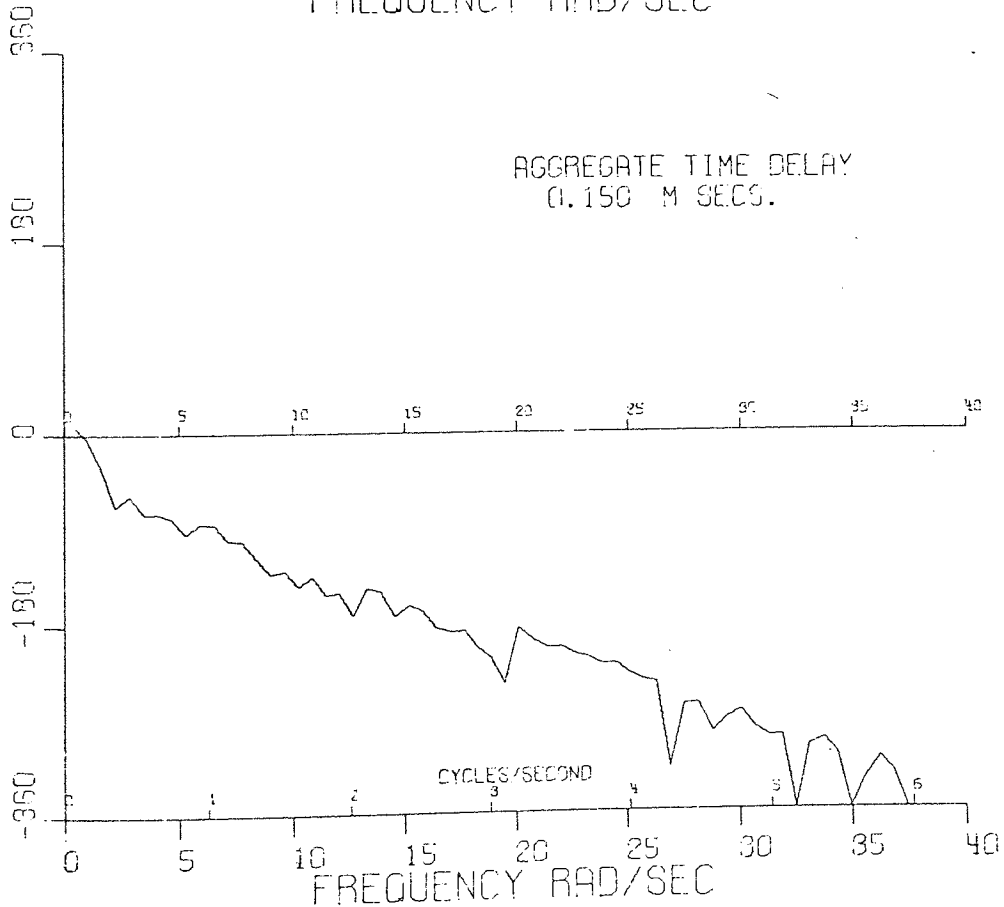

# FOURIER/MILNER CROSS SPECTRAL DENSITY ANALYSIS

G.D. WHITEHEAD

Figure 2.59

Cross Spectra  $C_{ie}$  &  $Q_{ie}$   
between Input and Error  
Waveforms.

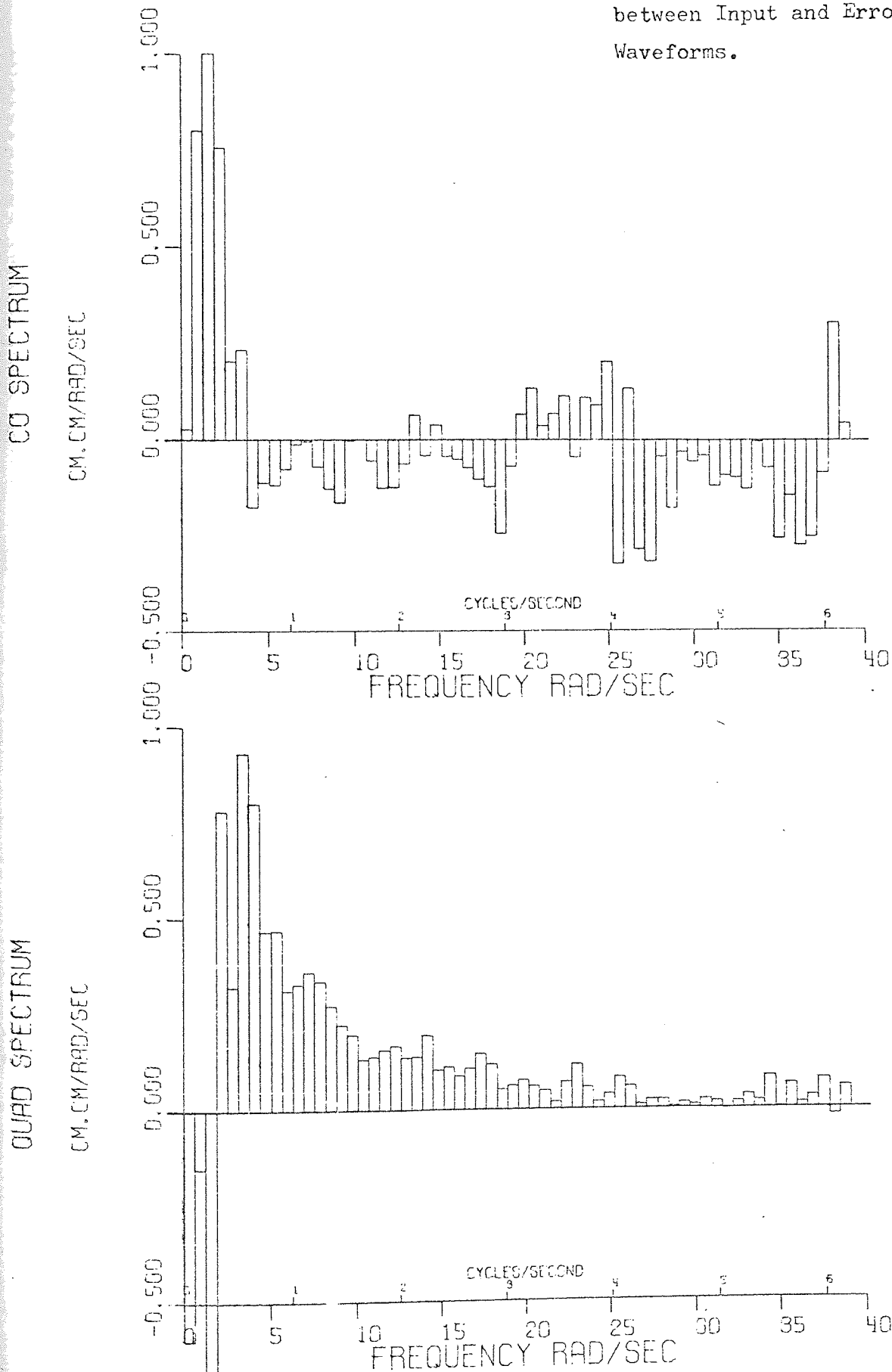

FOURIER/MILNER CROSS  
SPECTRAL DENSITY ANALYSIS

G. D. WHITEHEAD

MAX= 0.231550E 01

Figure 2.60

Crosscorrelation  $R_{ie}$  &  
KP diagram for Input &  
Error Waveforms.

CROSSCORRELATION COEFFICIENT

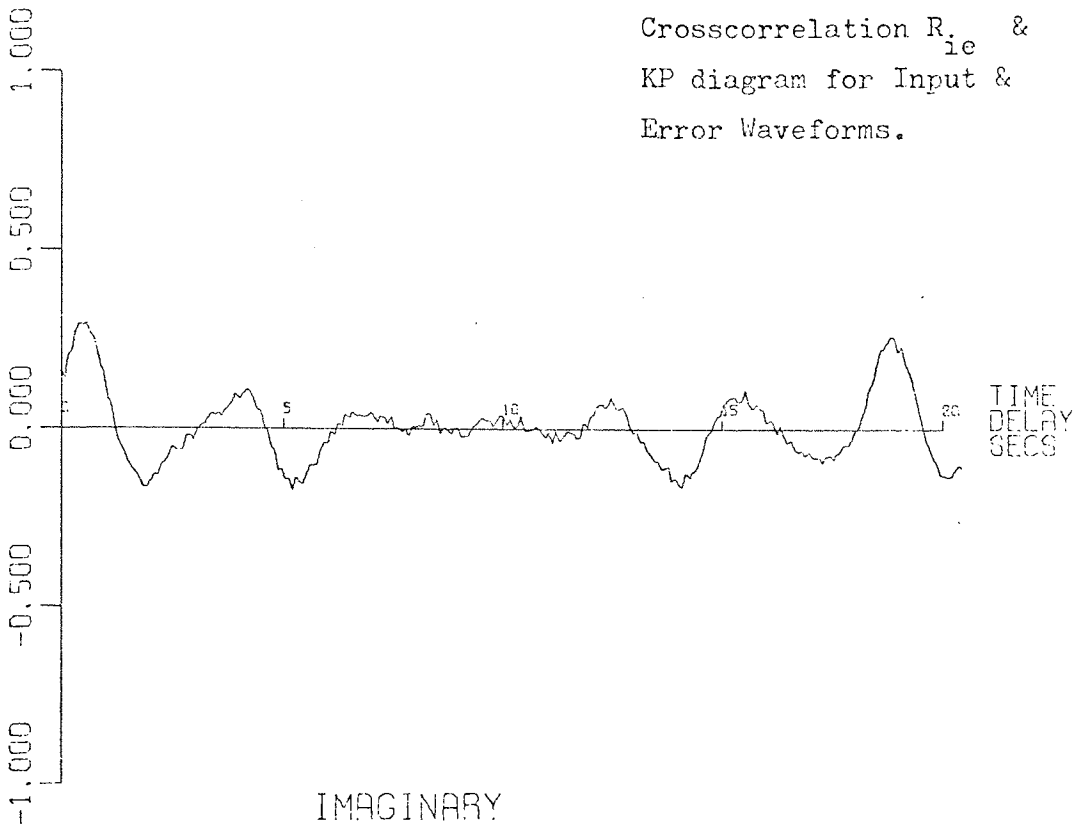

IMAGINARY

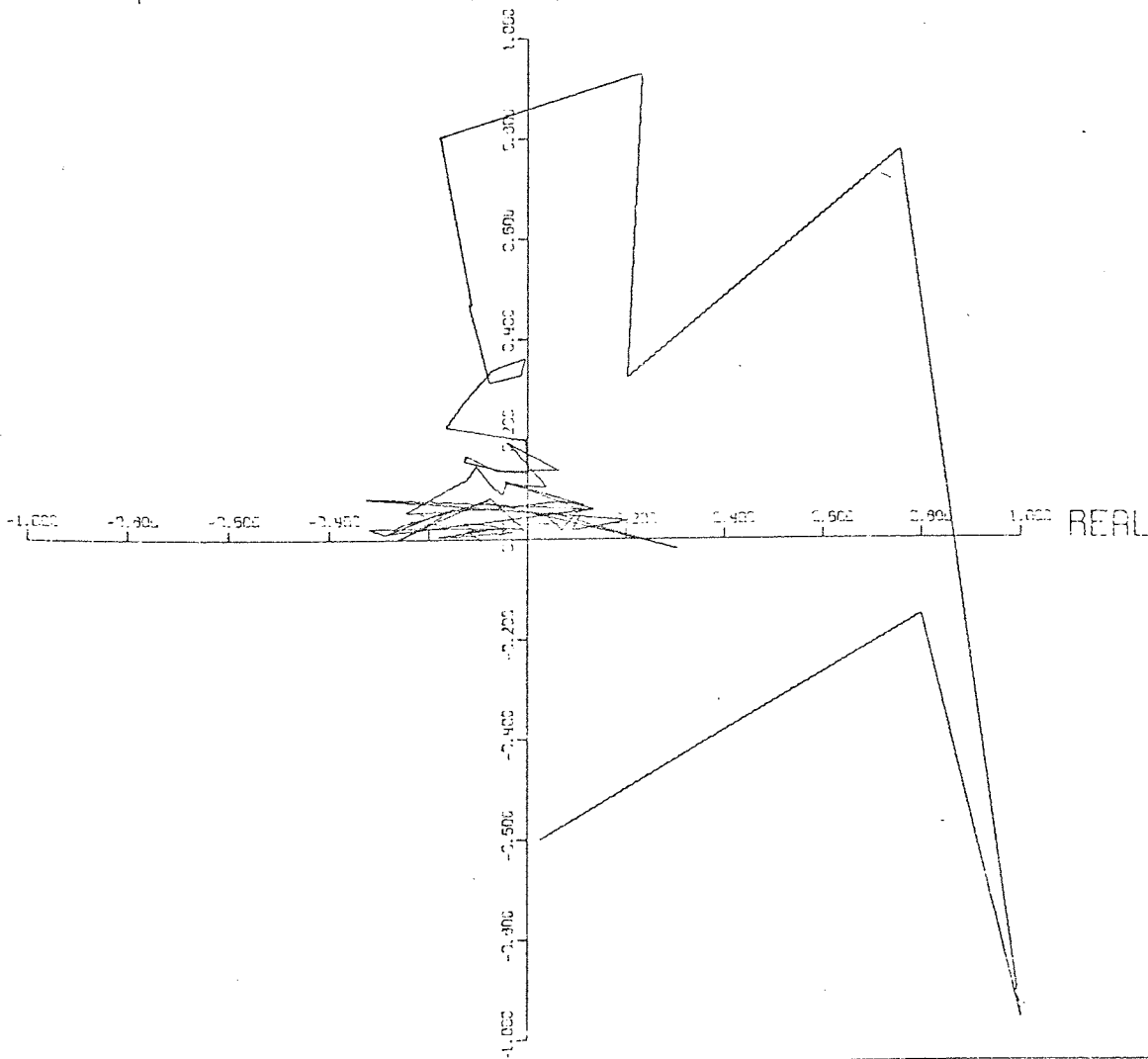

FOURIER/MILNER CROSS  
SPECTRAL DENSITY ANALYSIS

G.D. WHITEHEAD

Figure 2.61

Gain & Phase Spectra  
between Input and Error  
based on the ratio  $G_{ie}/G_{ii}$ .

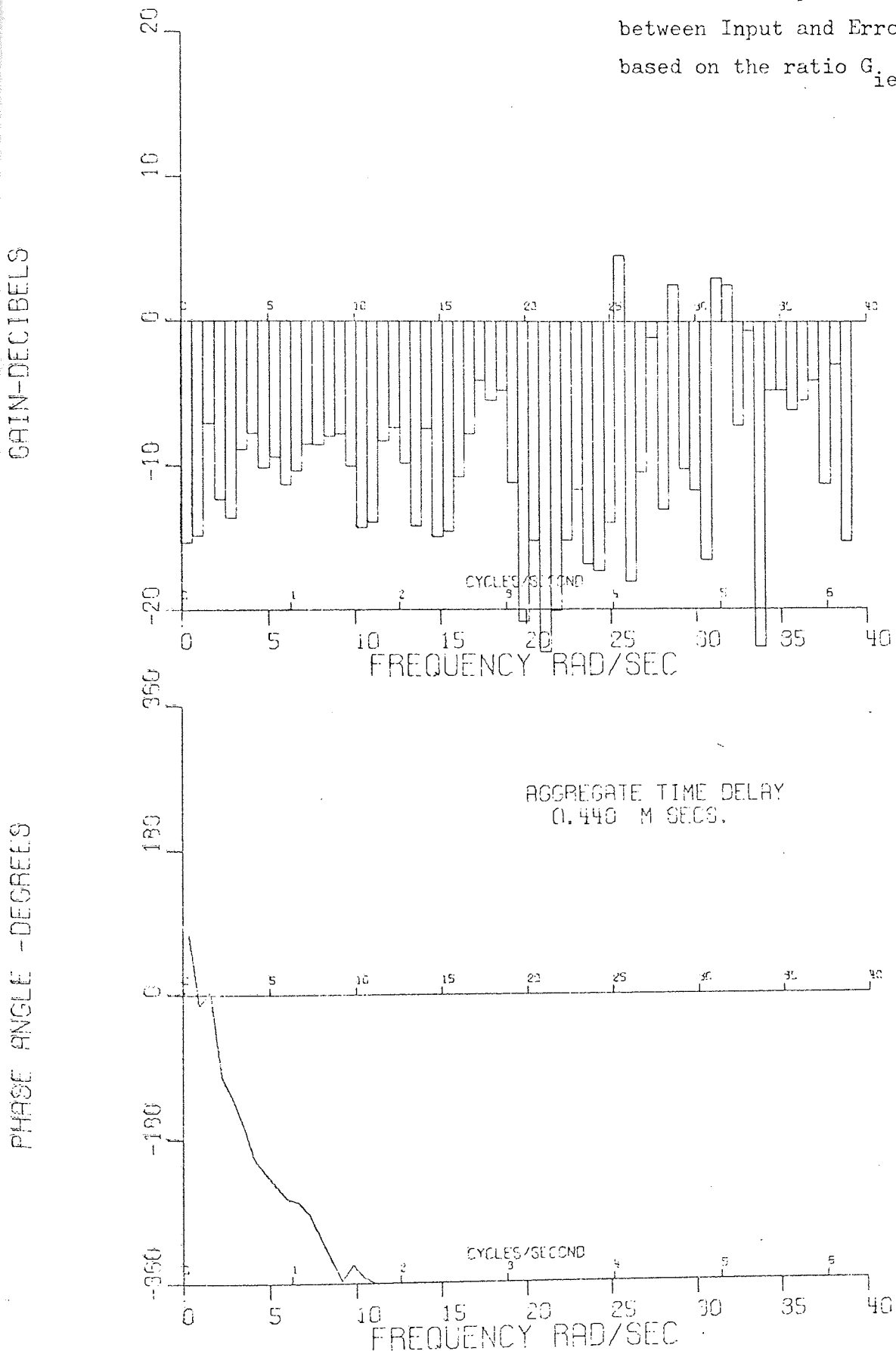

# FOURIER/MILNER CROSS SPECTRAL DENSITY ANALYSIS

G.D. WHITEHEAD

Figure 2.62

Cross Spectra  $C_{ic}$  &  $Q_{ic}$   
between Input and Control  
Movement.

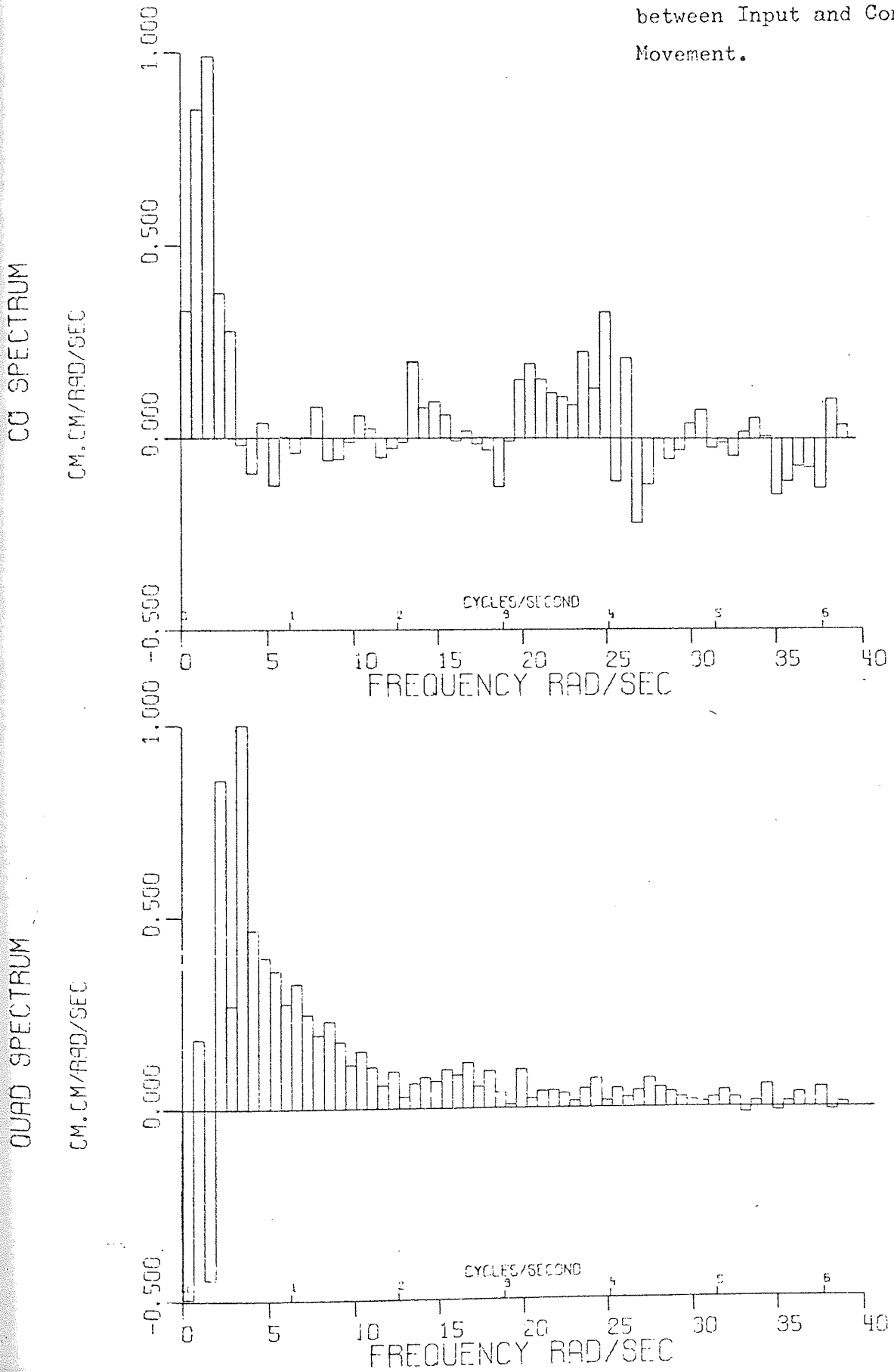

FOURIER/MILNER CROSS  
SPECTRAL DENSITY ANALYSIS

G.D. WHITEHEAD

MAX= 0.305153E 01

Figure 2.63

Crosscorrelation  $R_{ic}$  & KP  
diagram between Input &  
Control Movement.

CROSSCORRELATION COEFFICIENT

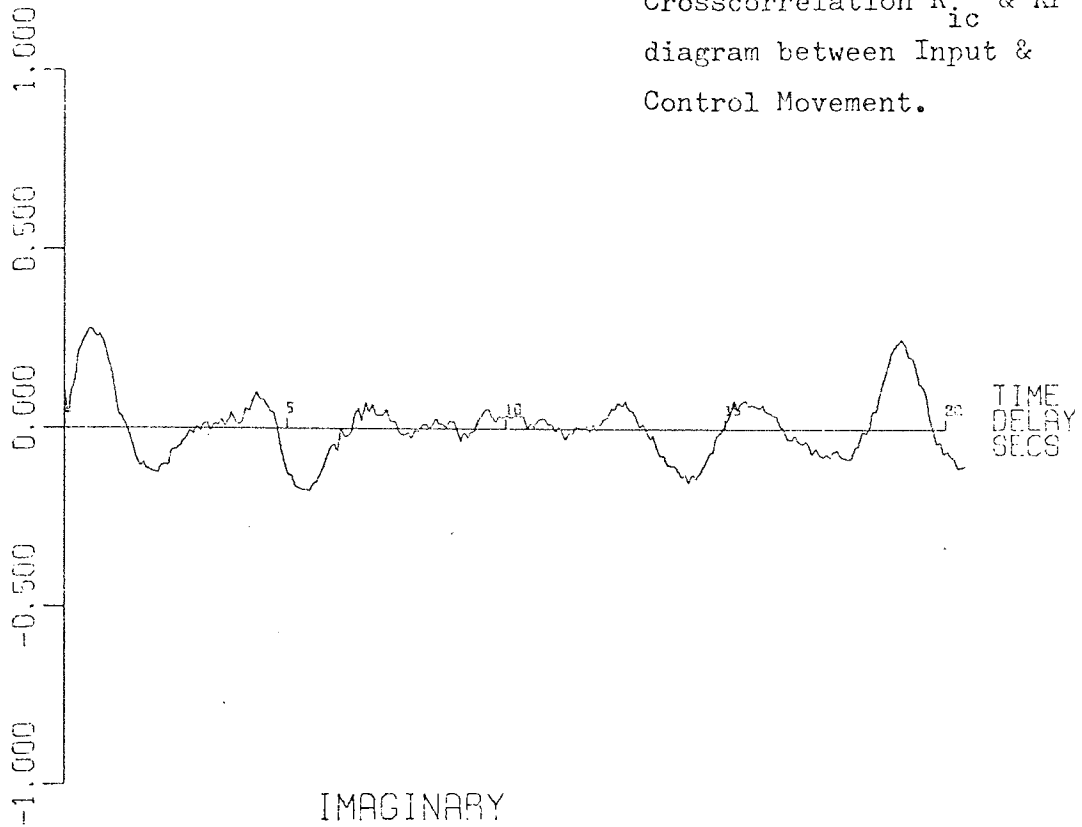

IMAGINARY

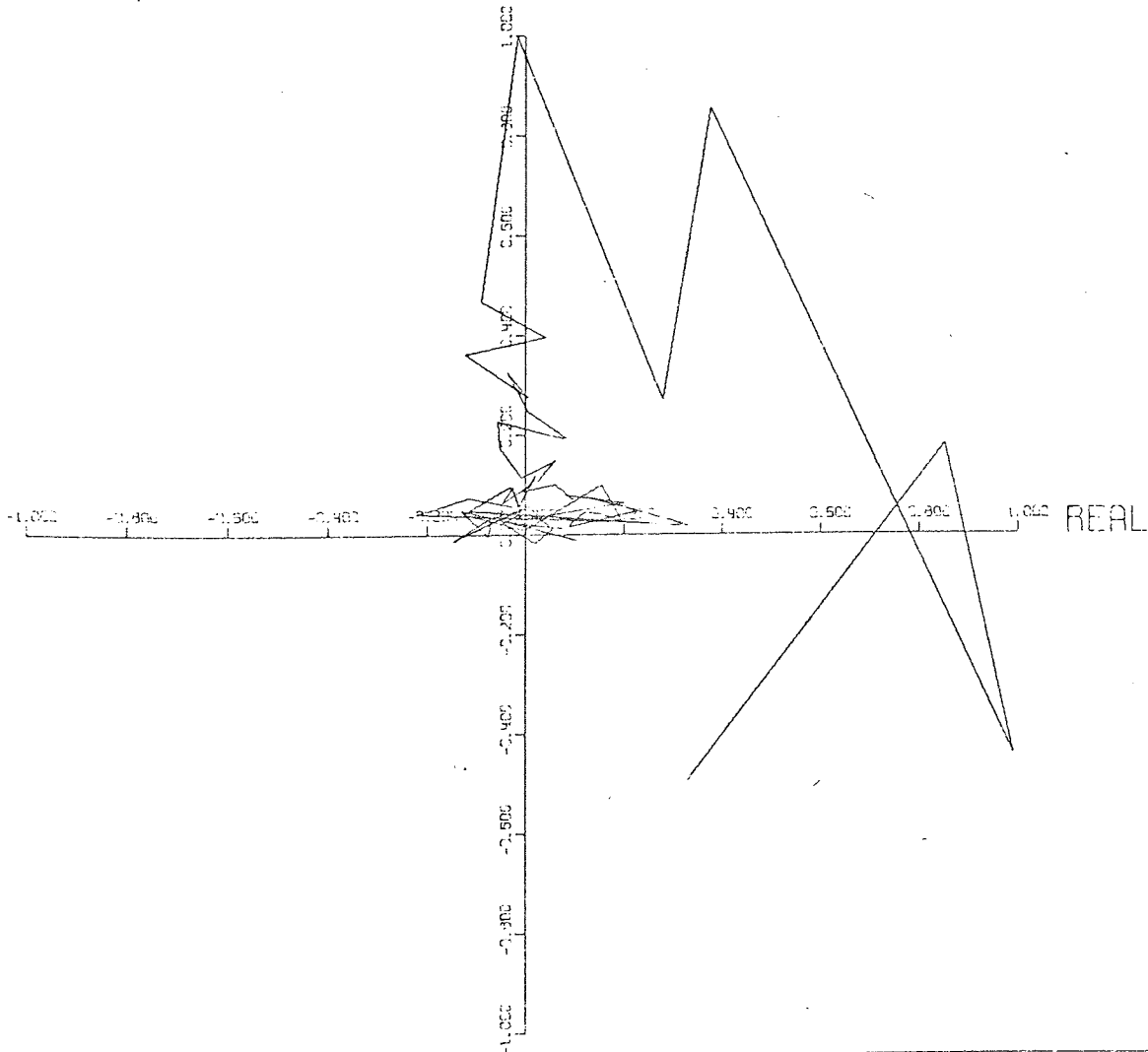

FOURIER/MILNER CROSS  
SPECTRAL DENSITY ANALYSIS

G.D. WHITEHEAD

Figure 2.64

Gain & Phase Spectra  
between Input and Control  
movement based on  $G_{ic}/G_{ii}$ .

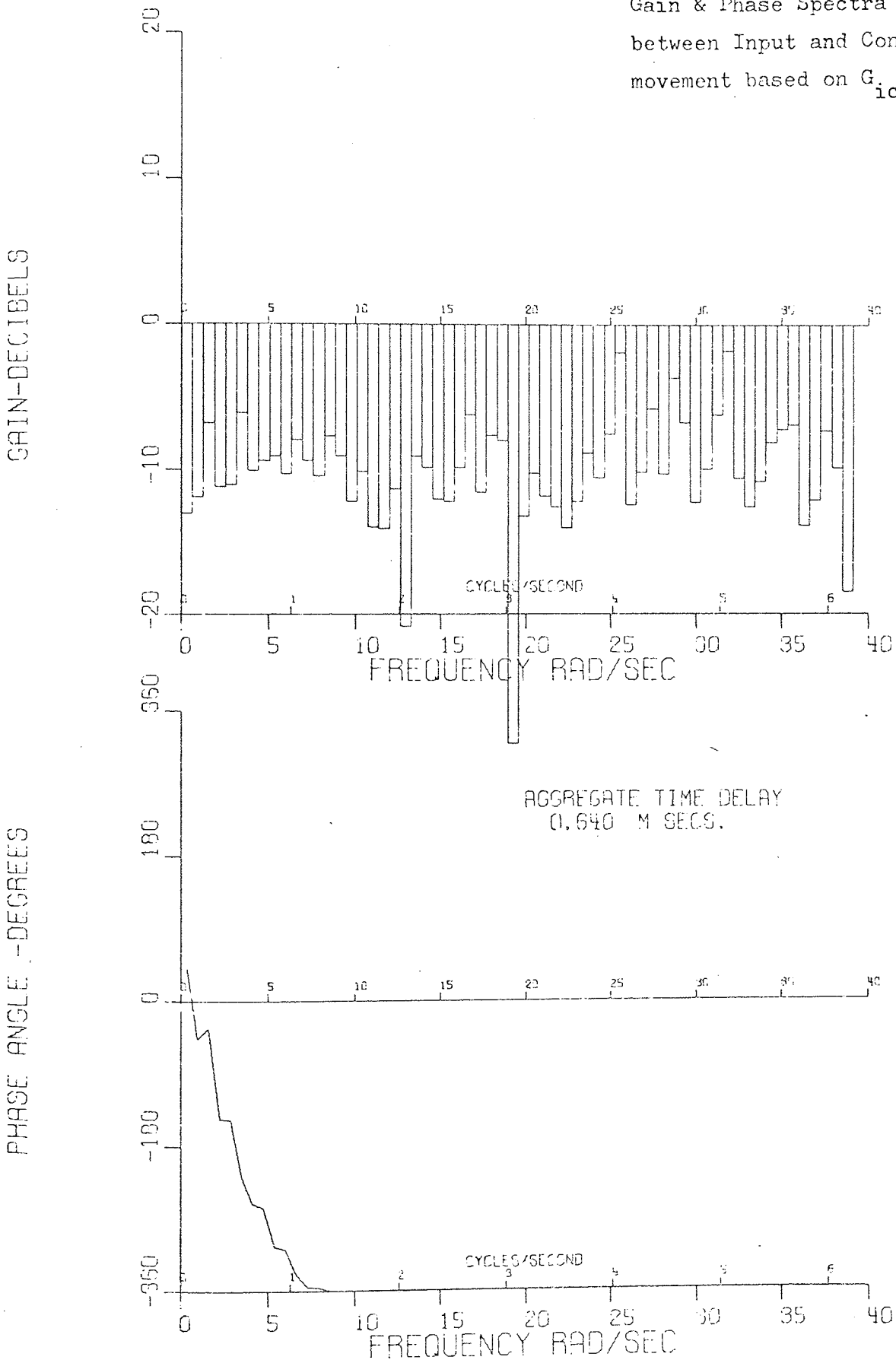

# FOURIER/HANNING TRANSFORM

C. D. WHITEHEAD

Figure 2.65

Crosscorrelation  $R_{ie}$  &  
Cross Spectrum  $G_{ie}$

$R(0) = 0.540240E 05$   
 $R(INF) = 0.334245E 05$

AUTOCORRELATION COEFFICIENT

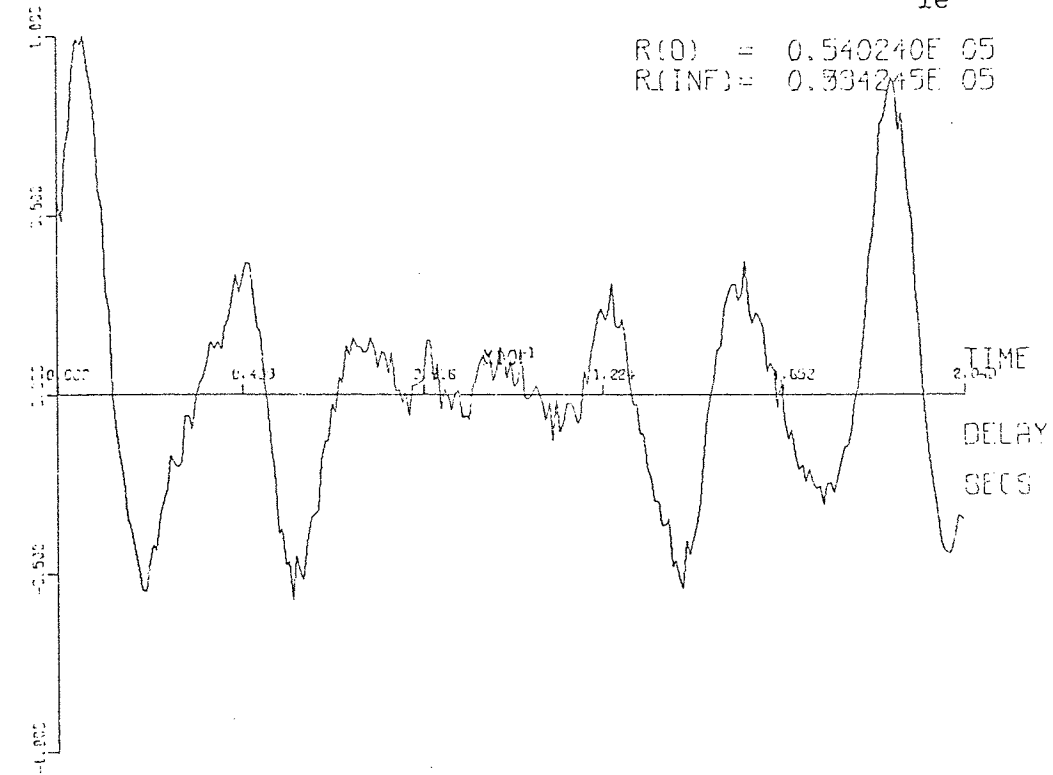

POWER SPECTRAL DENSITY

CM. CM/RAD/SEC

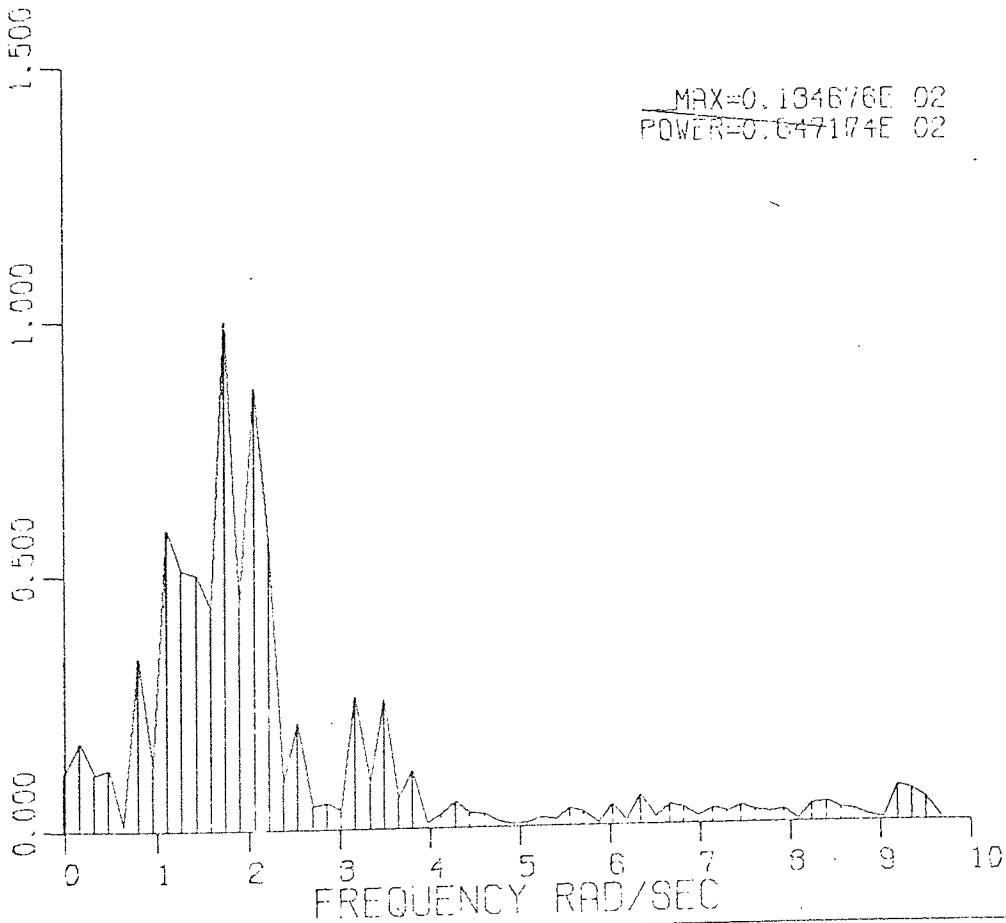

MAX=0.134676E 02  
POWER=0.647174E 02

FREQUENCY RAD/SEC

CYCLES/SECOND



FOURIER/HANNING CROSS  
SPECTRAL DENSITY ANALYSIS

G. D. WHITEHEAD

Figure 2.66

MAX= 0.159399E 02

Crosscorrelation  $R_{ic}$  & KP  
diagram between Input &  
Control Waveforms.

CROSSCORRELATION COEFFICIENT

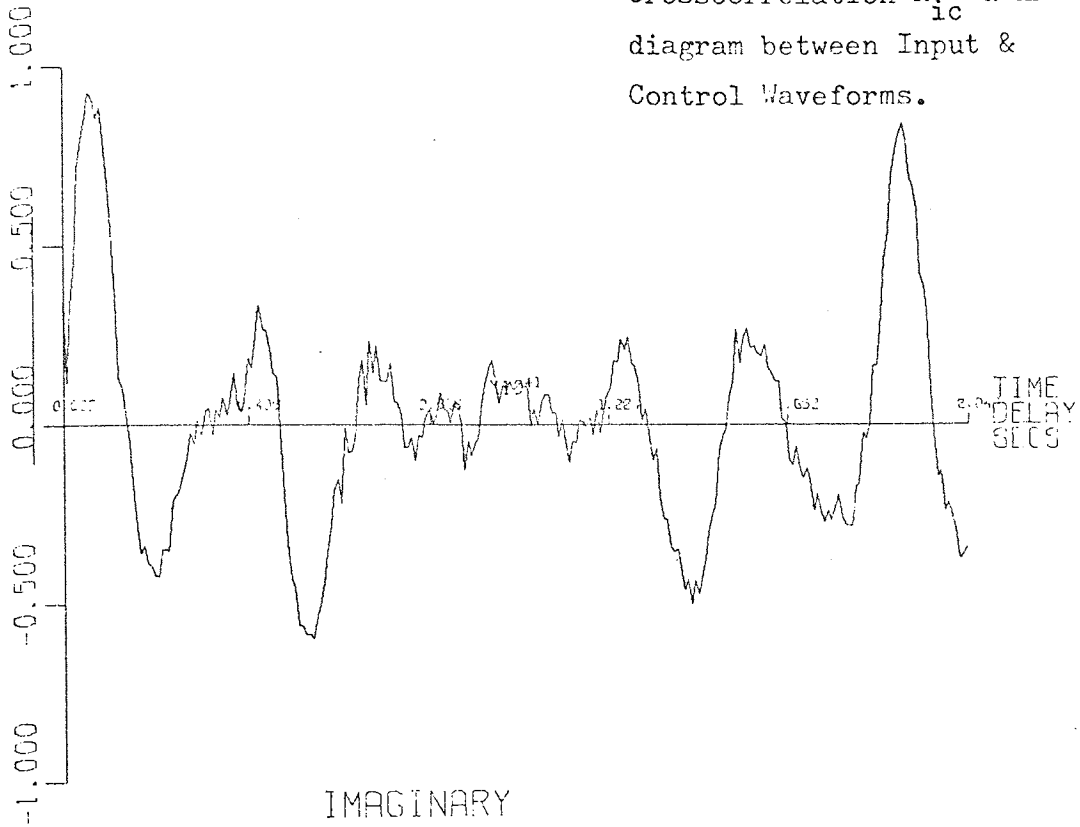

IMAGINARY

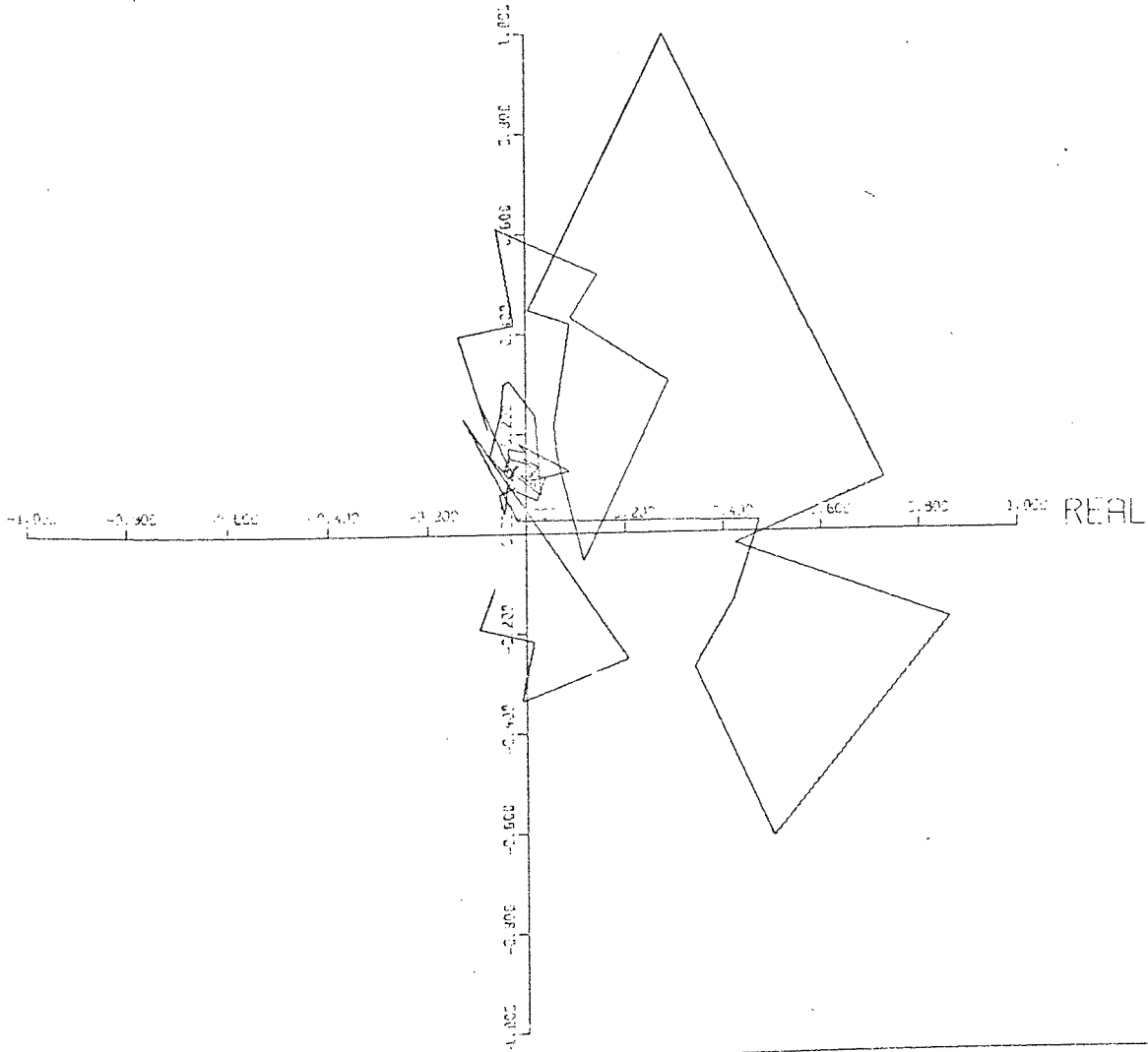

# FOURIER/HANNING CROSS SPECTRAL DENSITY ANALYSIS

G. D. WHITEHEAD

Figure 2.67

Cross Spectra  $C_{ic}$  &  $Q_{ic}$   
between Input & Control  
waveforms.

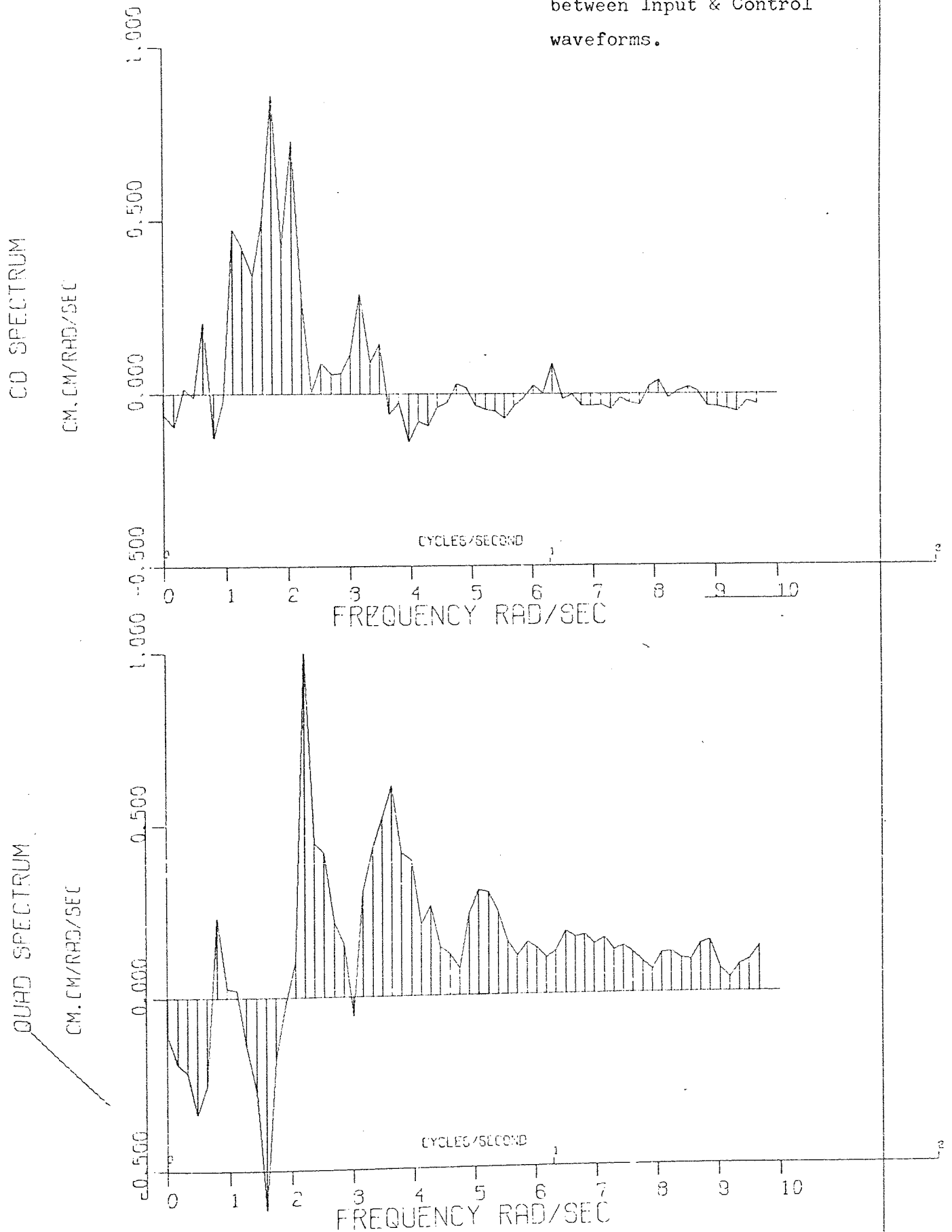

# FOURIER/HANNING CROSS SPECTRAL DENSITY ANALYSIS

G. D. WHITZHAD

Figure 2.68

Gain & Phase Spectra  $G_{ic}/G_{ie}$   
( Human Operator Describing  
Function  $Y_p$  ) between  
Input & Error & Control  
Waveforms.

GAIN-DECIBELS

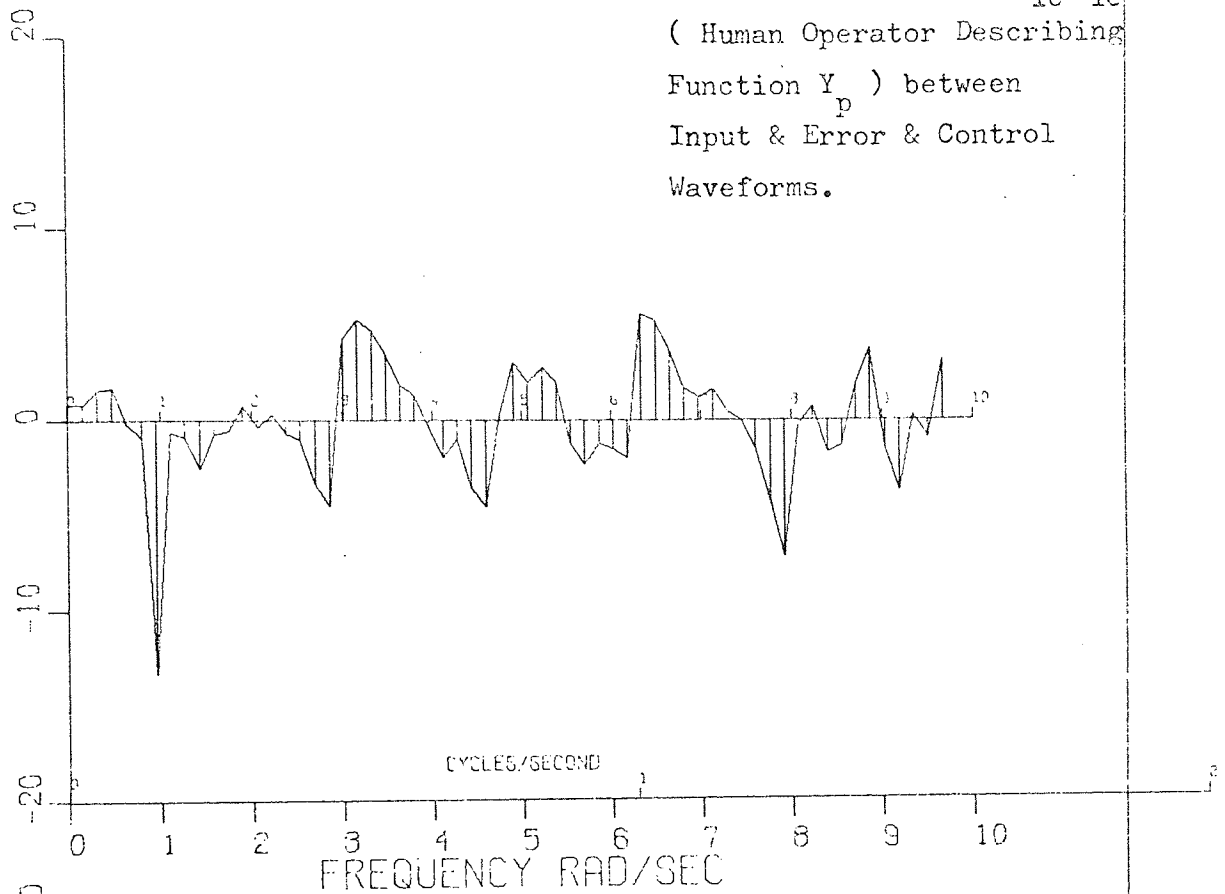

PHASE ANGLE -DEGREES

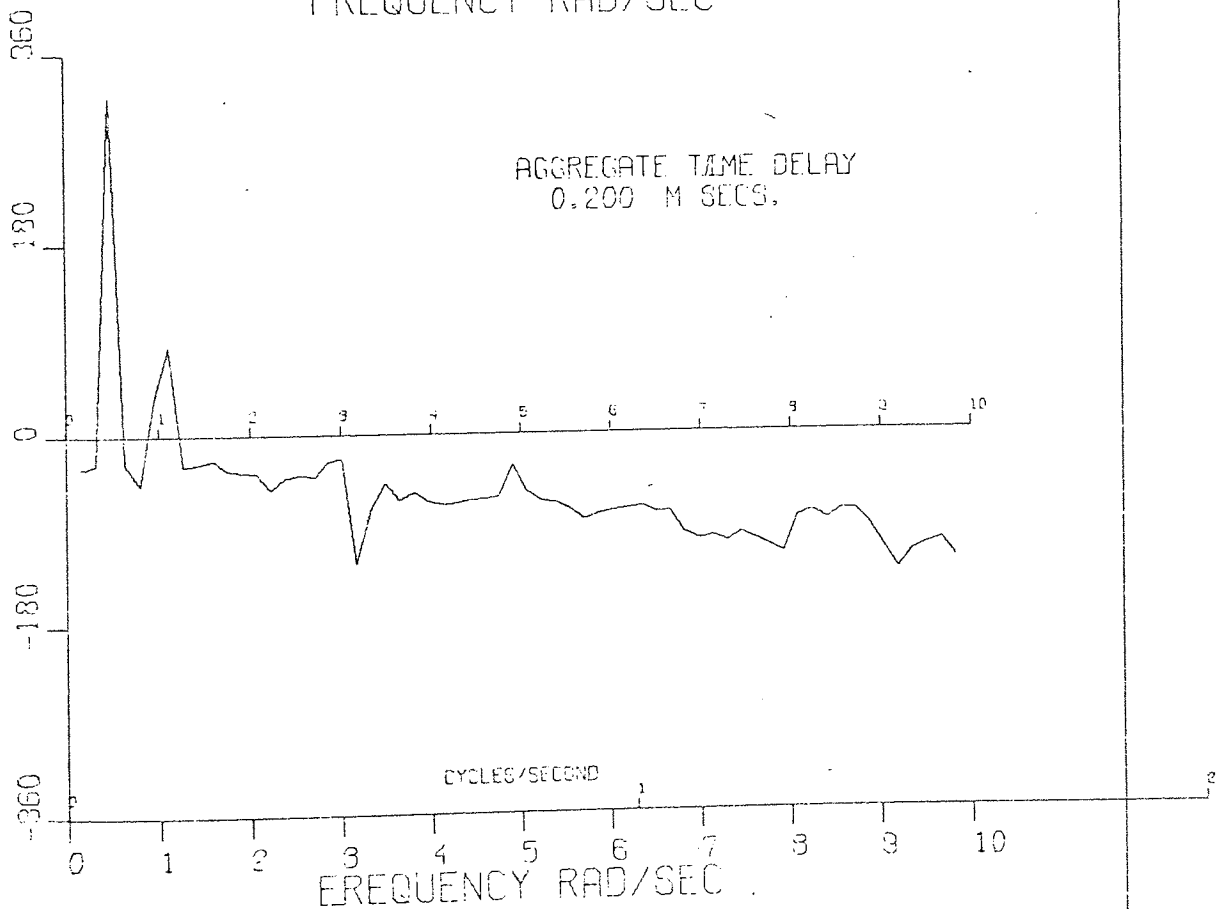

- (e) Input-Error Cross Spectrum  $G_{ie}$
- (f) Input-Control Cross Spectrum  $G_{ic}$

The ratios calculated were :

- (g)  $G_{ic} / G_{ie}$
- (h)  $G_{ic} / G_{ii}$
- (j)  $G_{ie} / G_{ii}$
- (k)  $G_{ec} / G_{ee}$

Ratio (g) is the Human Operator Describing Function  $Y_p$  and (k) is the same thing computed without reference to the input; (h) is the closed loop describing function  $Y_p / (1 + Y_p Y_c)$ ; (j) is the inverse of the combined man/machine describing function  $Y_p Y_c$  (plus unity).

The spectrum analysis program resulted in 448 graphs being plotted. For presentation purposes and in order to show how the individual spectra a-k change with time and vibration over the trial period the analyses for each trial have been compressed into 3 dimensional isometric diagrams. An example of spectra a-k together with the associated correlation functions from which they were derived is shown in Figs. 2.53-2.68. The analyses shown are for one subject B.H. who participated in the third experiment. The spectra refer to the ninth analysis epoch of his second trial with adaptive random vibration. The Auto, Cross Spectra and Spectral Ratios shown are typical of the control behaviour and transfer properties of all subjects who performed with the dual instruction to minimise deviation and to keep the line on the scope.

In general the spectrum analysis revealed that ;

- (a) There were large individual differences in the spectrum of control

Human Operator Describing Function  $Y_p$   
( subject TH, condition 'B' )

Figure 2.69

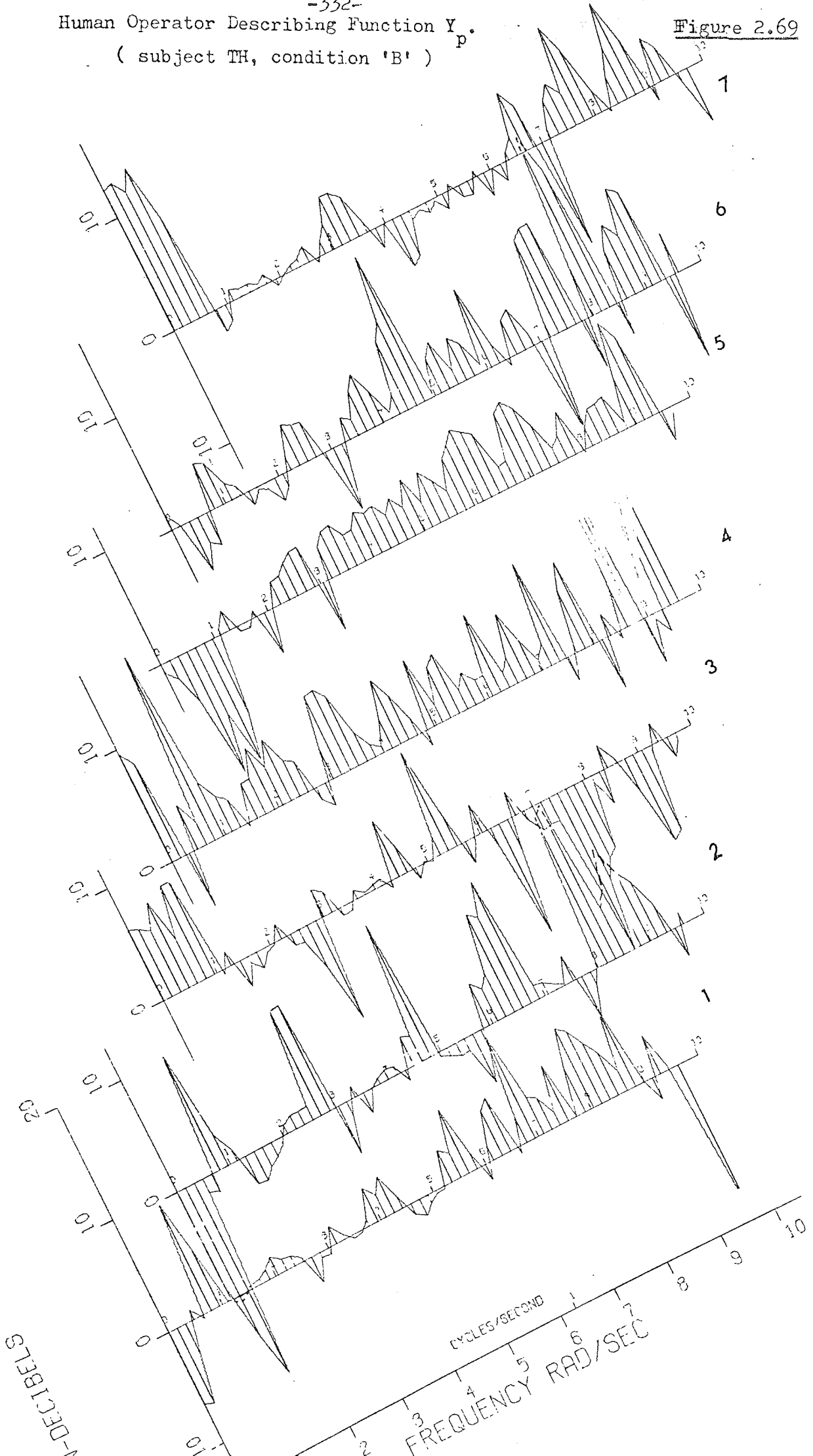

$G_{ec}/G_{ee}$  (subject TH Condition 'B')

GAIN-DECIBELS

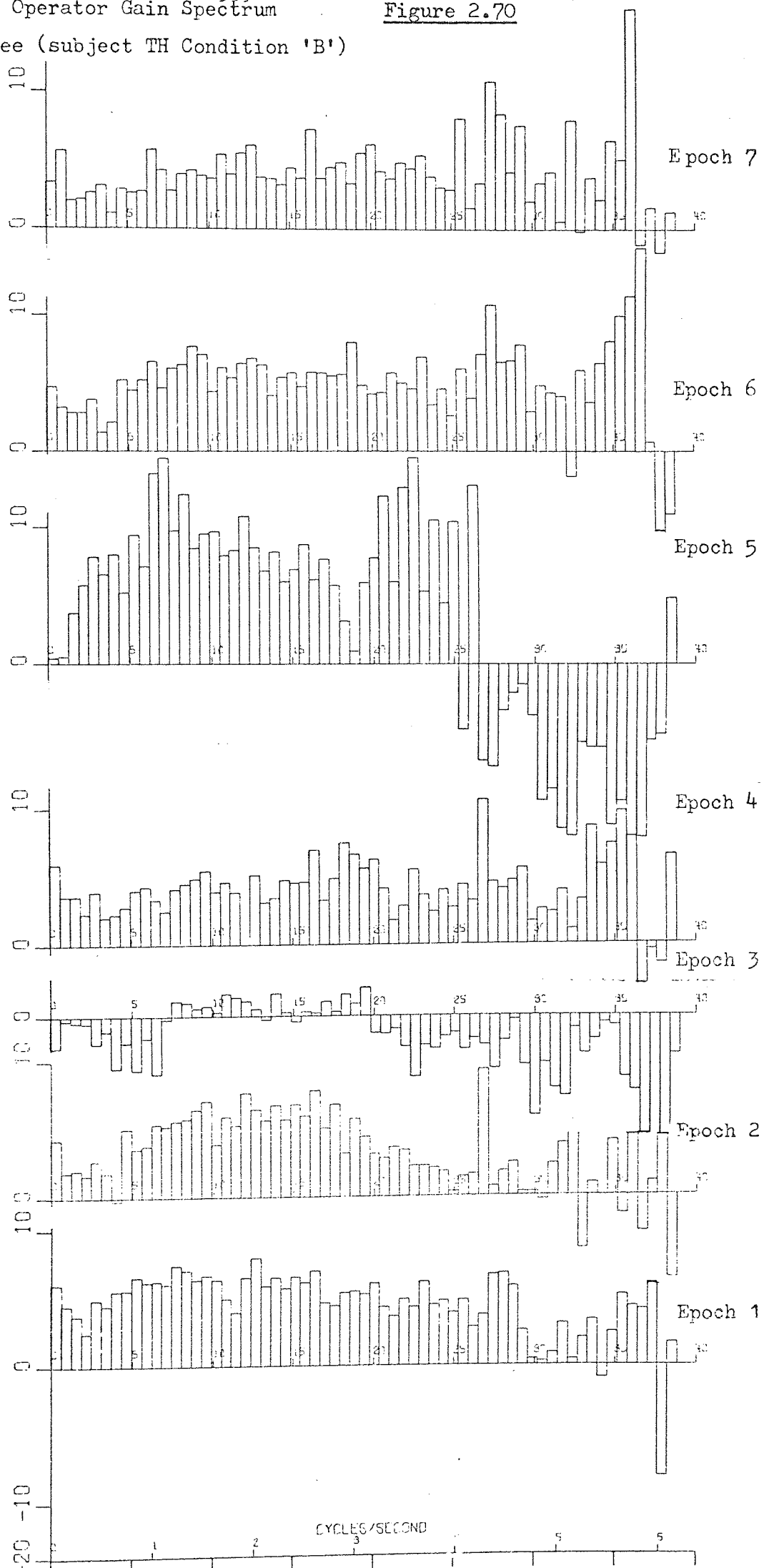

movement.

(b) In the region of frequencies (0-6.5 rads/sec.) the operators did not perform a simple equalisation function.

(c) The functions performed by the operators in the region of input frequency was non-linear. Their response to a Gaussian input signal was often sinusoidal in form.

(d) The Quasi Linear Describing function method for qualifying and quantifying control behaviour was largely inappropriate for the adaptive control task because in spite of instructions to the contrary subjects were drawn by the nature of the task towards the use of a timing skill and away from the normal space time skill associated with compensatory tracking. This resulted in coherence between waveforms which was never better than 0.258.

#### Individual Results.

Subject T.H. - Figures 2.69-2.70 are respectively the Quasi linear describing function  $Y_p = G_{ic}/G_{ie}$  and  $Y_p = G_{ec}/G_{ee}$  for the trial shown in Fig. 2.39. The control action spectra  $G_{cc}$  are shown in Fig. 2.71 a and 2.71 b, the error spectrum  $G_{ee}$  in Figs. 2.72 a,b and the cross spectra  $G_{ec}$  in Figs. 2.73 a,b.

From these spectra one deduces that :

- (a) Control actions are predominantly at a frequency of 8-9 rads/sec. (1.5Hz.) (Fig. 2.71).
- (b) The error signal contains a large proportion of the input signal (Fig. 2.72) suggesting that the subject was making little or no attempt to cancel the input signal whilst performing under condition B.
- (c) The subjects least gain occurred during the first of two non-stationary vibration responses (Fig. 2.70).
- (d) Maximum control effort, as given by the area under the PSD curve,

Figure 2.71a Auto Spectrum of Control movement during Non Stationary Vibration. (subject TH condition 'B')

G. D. WHITEHEAD

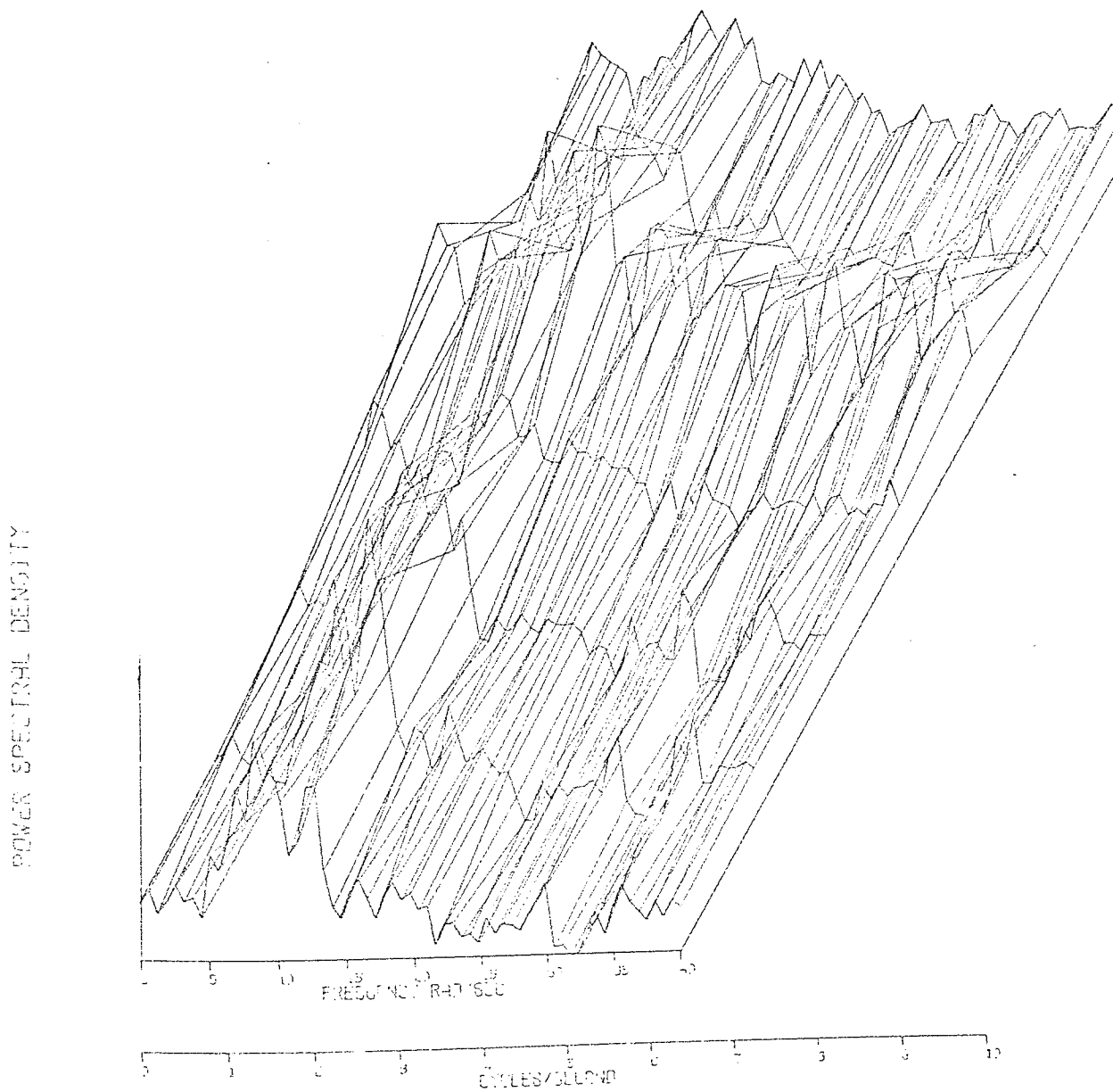



Figure 2.71b Inverted view of fig 2.70a.

C. D. WHITEHEAD

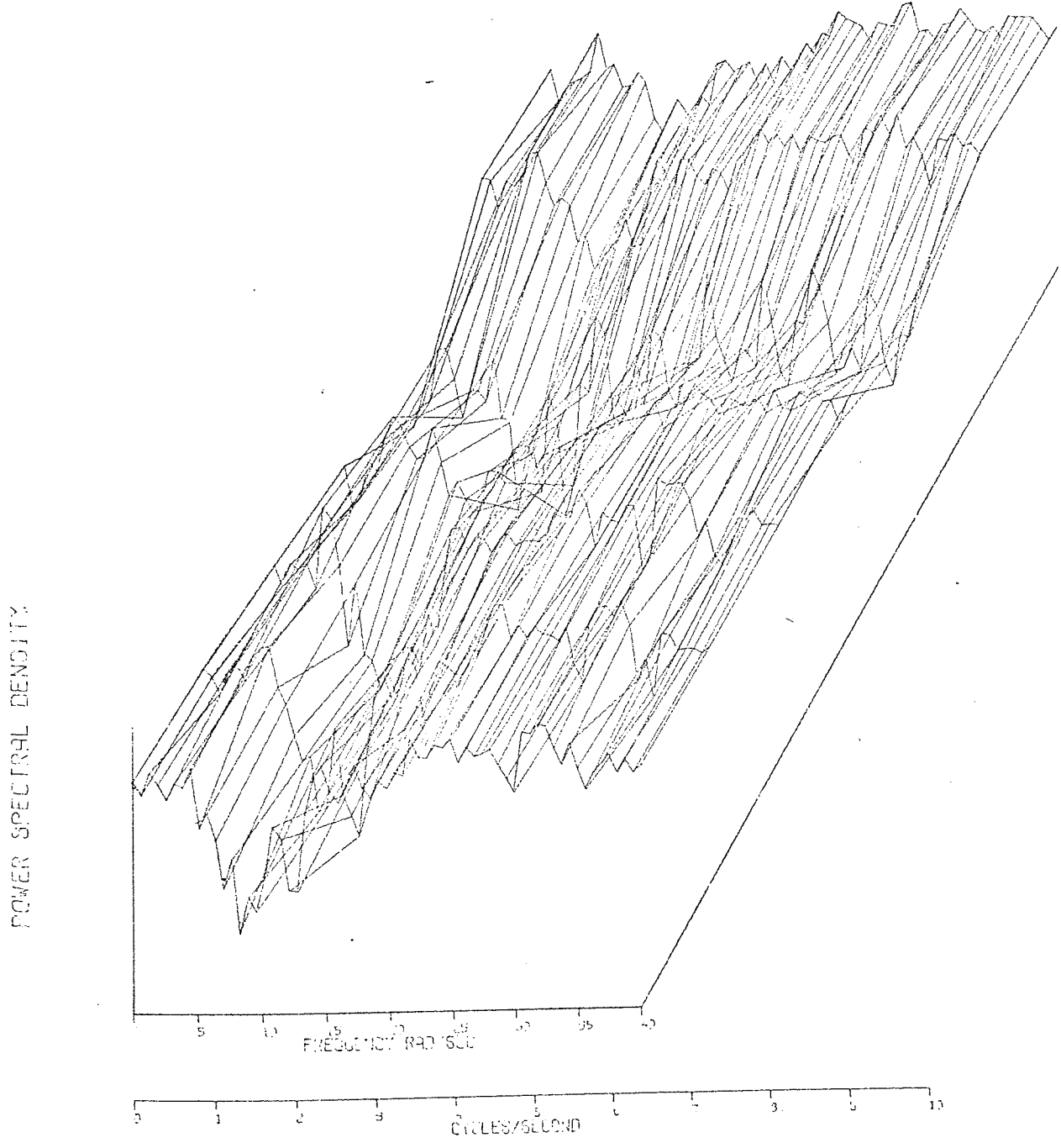

Figure 2.72a Auto Spectrum of Error Signal  
during Non Stationary Vibration  
( subject TH condition 'B' )

G.D. WHITEHEAD

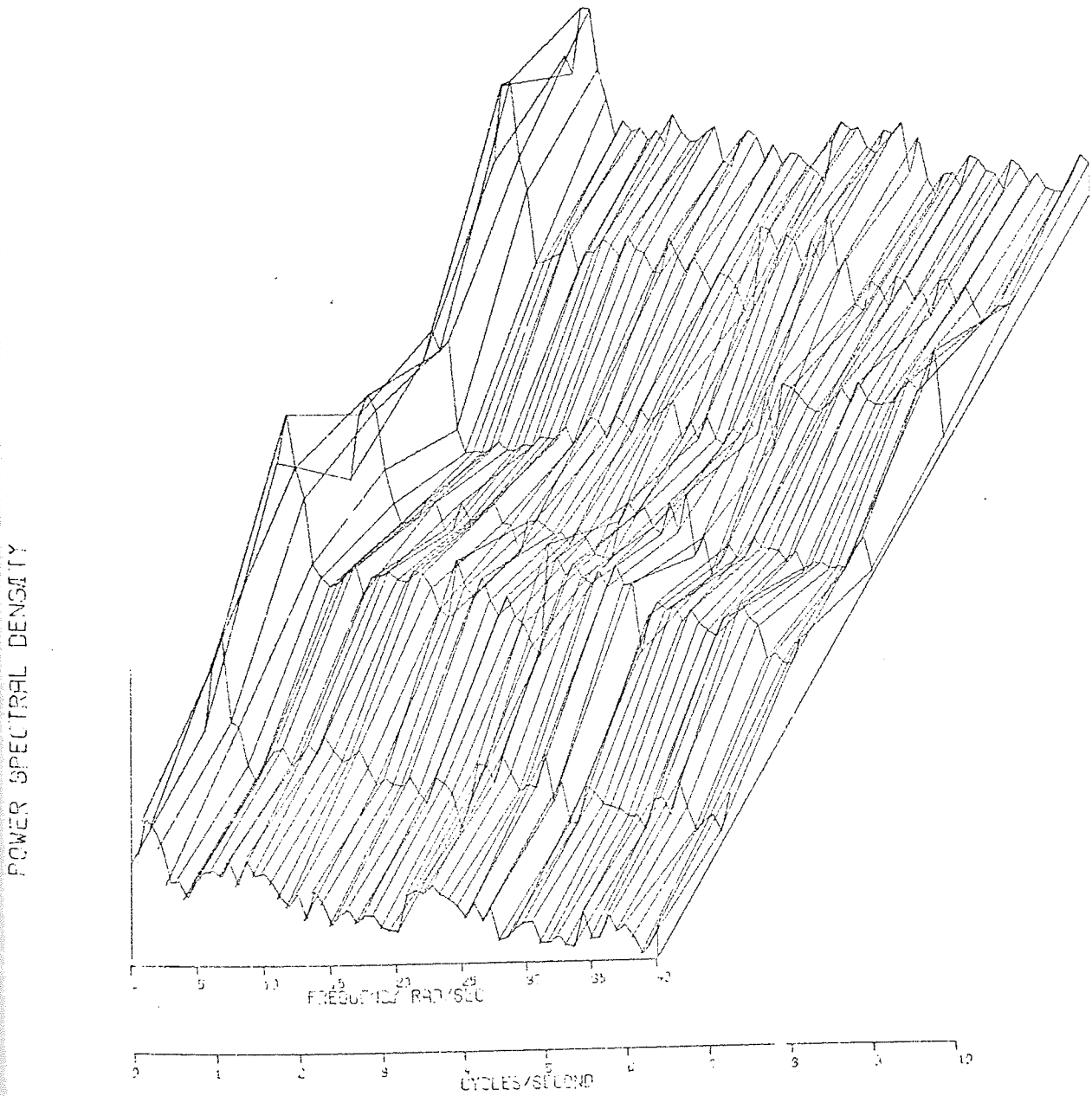

Figure 2.72b A Reverse view of fig 2.71a

G.D. WHITEHEAD

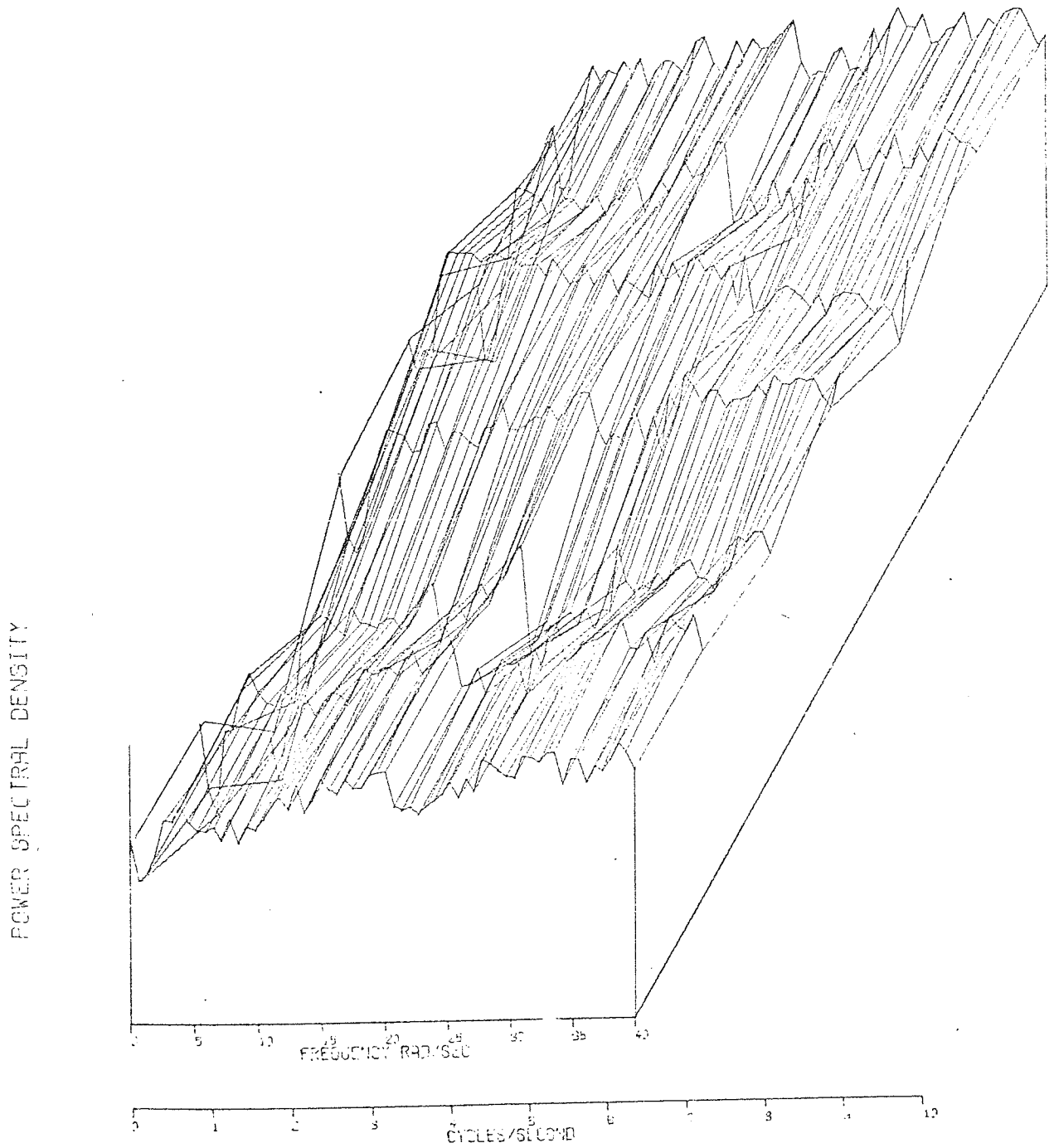
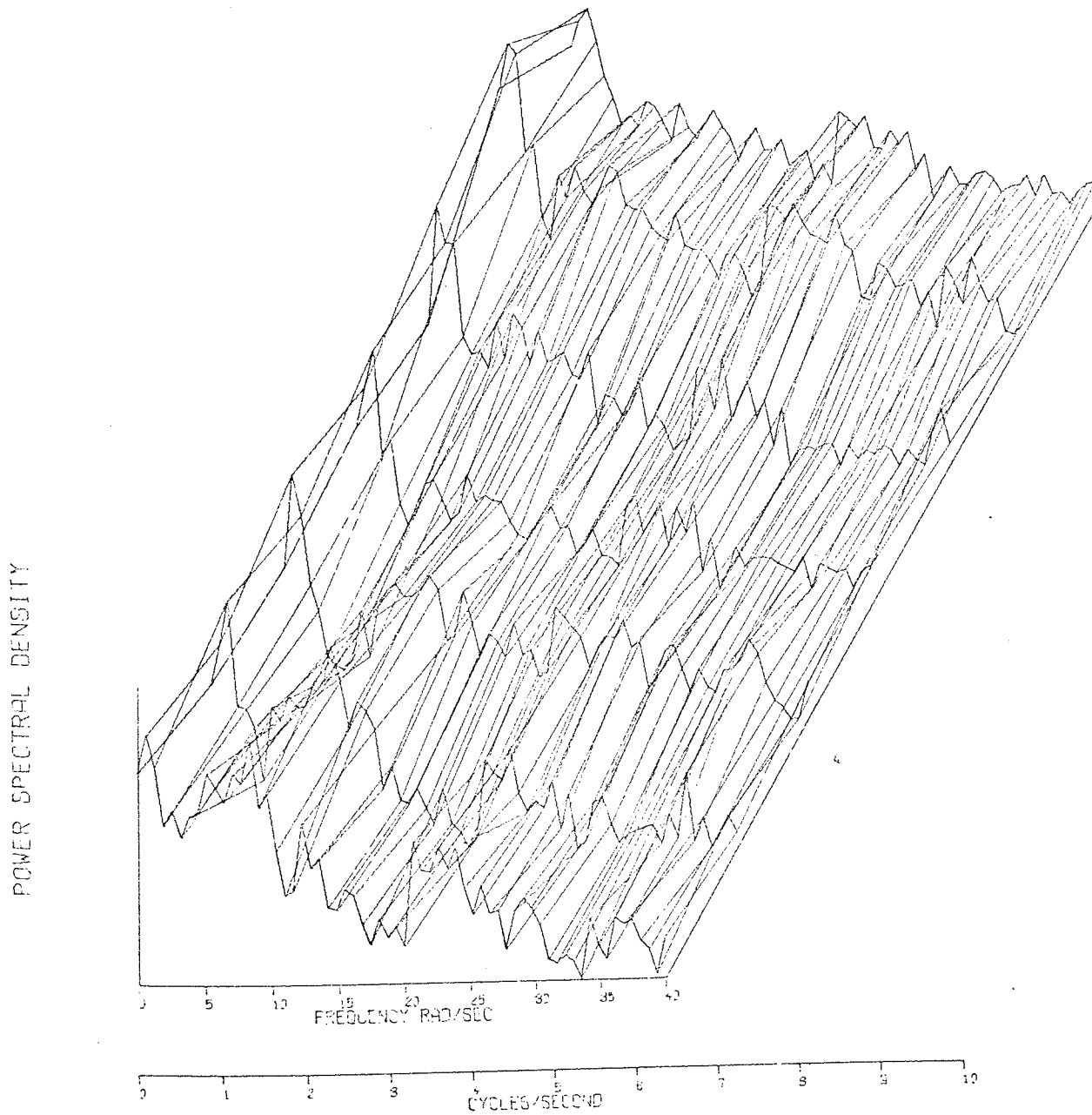

Figure 2.73 Cross Spectrum  $G_{EC}$  between  
Error & Control movement  
during Non Stationary Vibration  
(subject TH Condition 'B')

G.D. WHITEHEAD



was greatest during the second non-stationary vibration exposure (analysis epoch no.5) a finding which is supported by the describing function Fig. 2.70 which shows that gain was also a maximum during that epoch. The interpretation of Fig.2.70 - epoch no.5, is that the operators response was about three times as great as the line movements that he was observing in the frequency region 5-10 rads/sec. This means that he was reducing to one third that part of the error signal which he was himself generating. The input command signal which was below 4rads/sec. was reduced to about one half(6 db) of its displayed value meaning that the operator was compensating for about 50% of the line movement due to the input. The other describing function, Fig. 2.69, which is focussed in the region of the input, shows that for the same epoch between 2-3 rads/sec., gains were about 1.4(3db) ie. a 30% compensation for movement of the error line. During this epoch at frequencies below 2rads/sec., the gain of -10db. indicates that the operator was doing very little to compensate for that part of the input signal.

The interpretation of these findings for this individual is that the drop in index of difficulty which was shown to occur (Fig.2.39) with each non-stationary vibration exposure was due to distinct and opposite causes. During the first exposure the drop was caused by a lowering of effort as indicated by gain which was at a minimum<sup>at</sup> this time (epoch no.3, Fig.2.70). This would have the effect of increasing the overall man/machine response time both to the input command signal and to the component in the display that the operator was himself generating as a result of bang-bang control movement. During the second exposure to vibration the subject raised his gain 3-4db. by increasing the amplitude of his bang-bang movements. Because of the adaptive logic, the effect of this was to lower the index of difficulty due to the spurious increase in error caused by the larger amplitude oscillations.

It is not at all clear why the effect of the first vibration should be to depress the subject whilst the second aroused him. During the first exposure to vibration the subject lost control. He also lost control at the beginning of the second exposure. It was after this event that his effort/gain rose so it may have been that he became more determined to retain control.

Fig. 2.72 is the cospectrum part of the cross spectrum between error and the control action waveform. This is the spectrum which occurs jointly between these waveforms as determined by linear product moment correlation. Power at frequencies below 4rads/sec. is the result of the input signal appearing in both the display and control movement waveforms. Frequencies above the input between 4 and 18 rads/sec. are due to the operators induced strategic movements being fed back, via the controlled element, into the compensatory display. On both counts his behaviour towards what he sees appears to be consistent over time and unaffected by vibration.

Subject D.P. - According to Fig. 2.40 the ability of D.P. was rather poor but little effected by vibration. Time delay analysis, Fig.2.51, revealed that his reaction time to display movement was slow compared to the other subjects. His low transfer gain characteristic in Fig.2.74 explains why this was so. For the first three minutes during vibration at task frequencies between 5 and 15 rads/sec. his gain fell to a value of about 1.25(2db). Below 5 rads/sec. it appears from the negative gain as though he was doing nothing to compensate for the input signal, an appearance which the more detailed analysis in Fig. 2.75 largely confirms. This low value of gain is responsible for the large jump in reaction time at epoch no.4 in Fig.2.51. The dominant bang-bang frequency adopted by this subject was 3-7rads/sec. (0.5-1.1Hz.) but a consistent bang-bang movement did not emerge until after

Figure 2.74

-342-  
Subject DP-Condition 'B'- Gain  
Spectrum  $G_{ec}/G_{ee}$  between Display  
& Control.

GAIN-DECIBELS

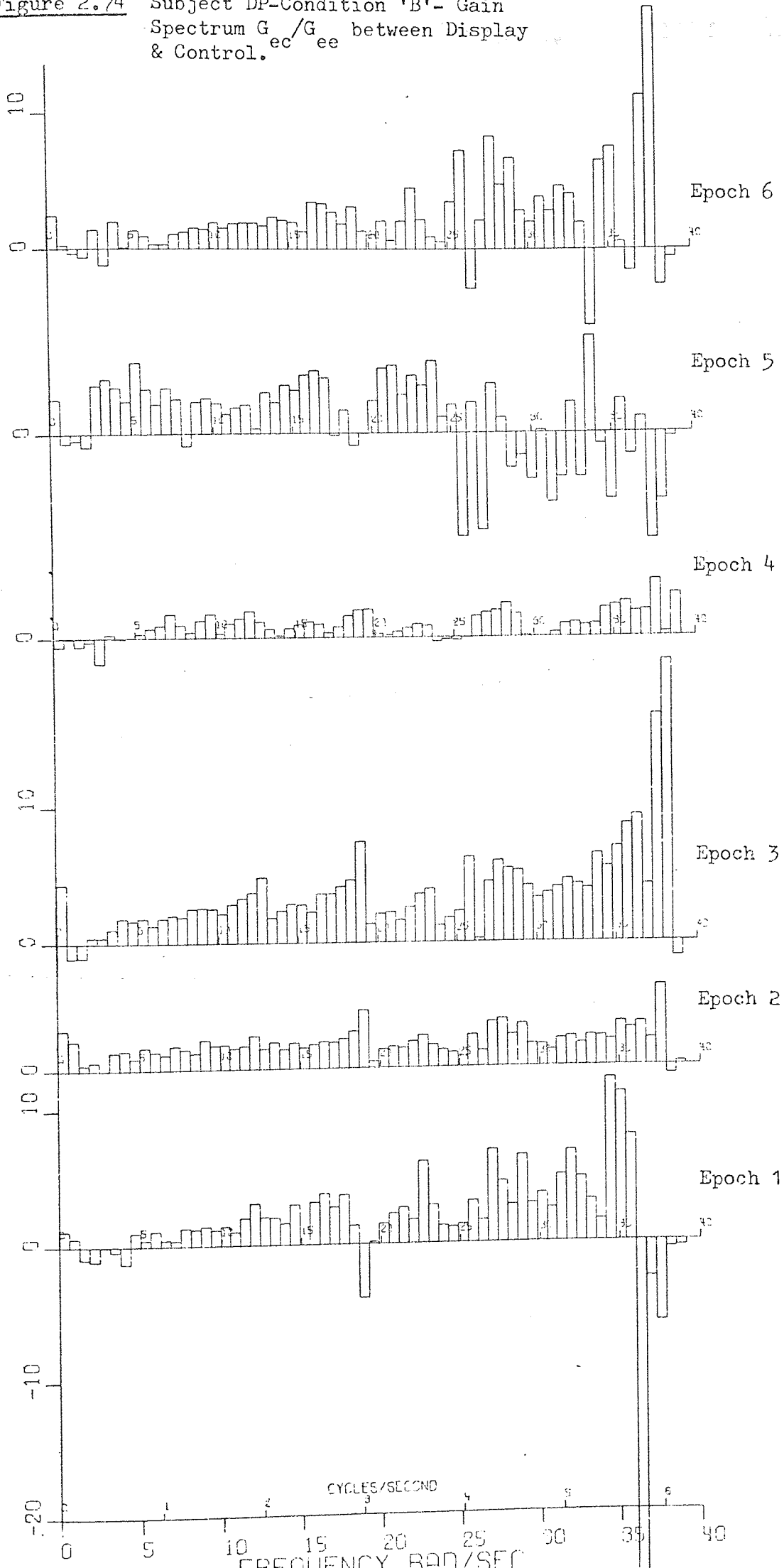

Subject DP, condition 'B' - Gain Spectrum  $G_{ic}/G_{ie}$   
Input, Display and Control movement.  
( Human Operator Describing Function  $Y_p$  )

Figure 2.75

GAIN-DECIBELS

GAIN-DECIBELS

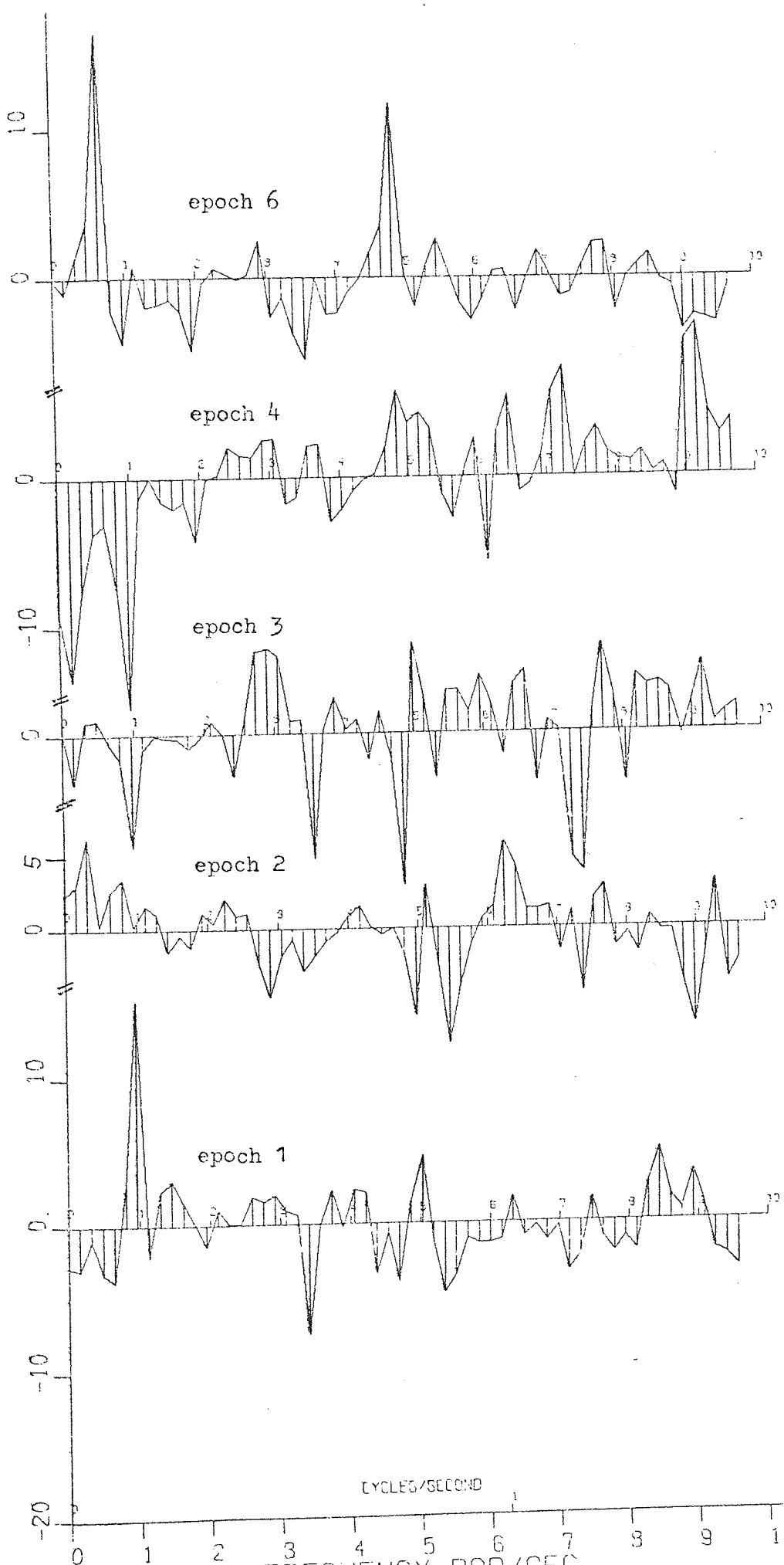
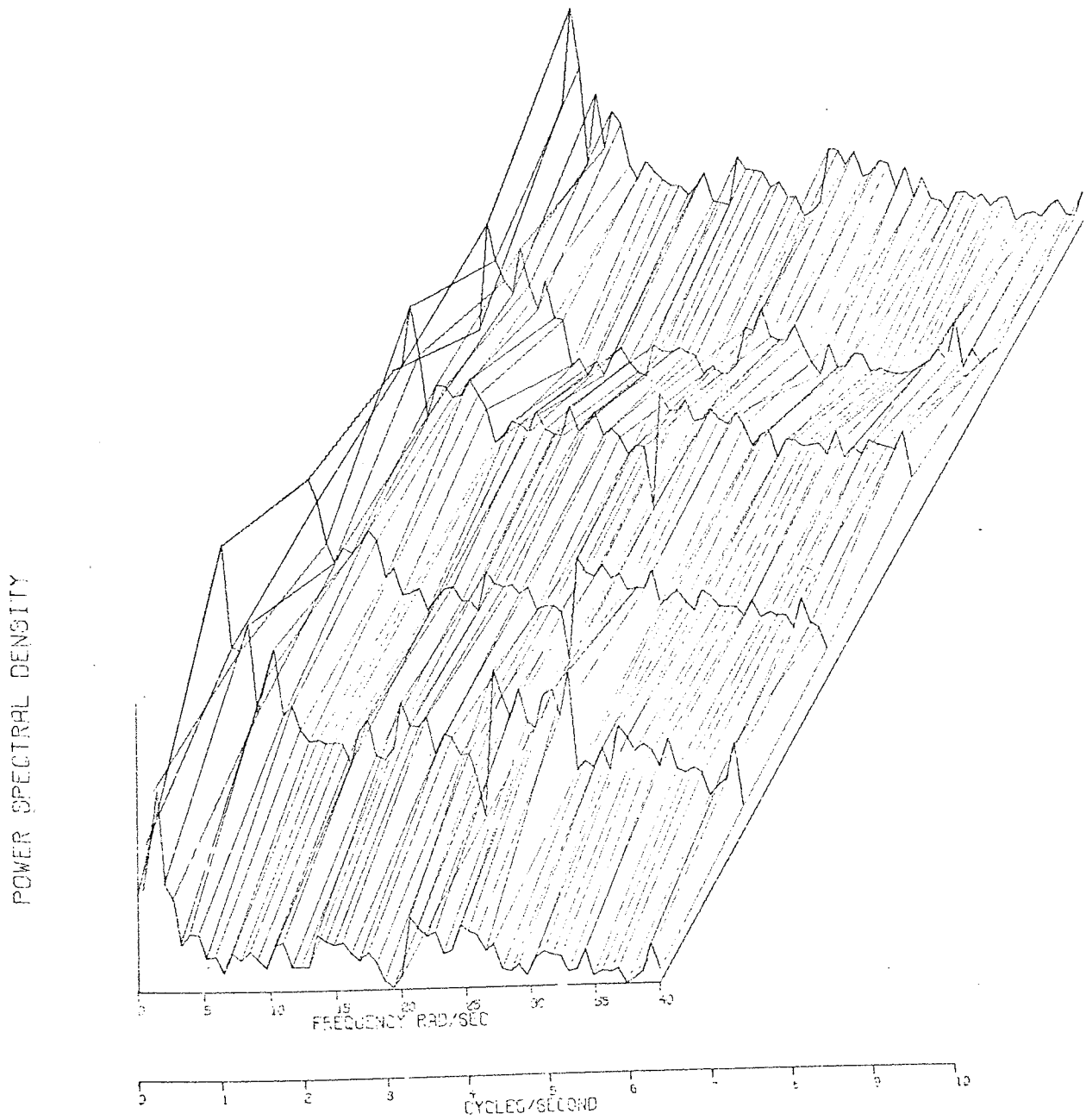



Figure 2.76 Cross Spectrum  $G_{\hat{e}^c}$  between G.D. WHITEHEAD  
Display & Control movement  
during Non Stationary Vibration  
(subject DP, condition 'B' )



onset of vibration. The cross spectrum  $G_{ec}$  in Fig.2.76 at epoch no.5 shows a distinct fall in the correlated power between error and control waveforms in spite of the fact that during this epoch his control actions were more energetic. This result suggests that vibration was interfering with the subjects intended control movements.

Subject K.D. - The task spectra and describing functions for this subject are shown in Figs.2.77-2.80.  $Y_p$  based upon  $G_{ec}/G_{ee}$  shows an arousal effect during the rising part of the vibration exposure shown in Fig.2.42. During the first exposure it rose from an average 3.75db. to 8.0db. The control spectra  $G_{cc}$ , Fig.2.79 does not reflect an increase in control movement power but the error spectrum Fig.2.78 does show a fall in error power at the 3rd. epoch. This indicates that the gain was accomplished by improved reaction time and tracking accuracy rather than larger control movement. Improved reaction time is manifested in Fig.2.79 as a slight increase in power on the region around 4 rads/sec. Increased gain during the second build up of vibration resulted from larger movements of the control as indicated by the increased power level in the control spectrum at epoch no.6.

For this trial K.D. was given the dual control objective which resulted in her switching between a mild form of bang-bang control and precise compensatory tracking. This change in control policy shows up in Fig.2.42 as an abrupt rise in the index of difficulty coincident with falling vibration intensity in the first vibration cycle. In the cross spectra Fig.2.80 the switch to precise comp. tracking is manifested as a fall in the power level at the fifth epoch. This happens for two reasons, first the power of the self-induced bang-bang motion is absent from both display and control and second because the increased controlled element gain implied by the increase in the

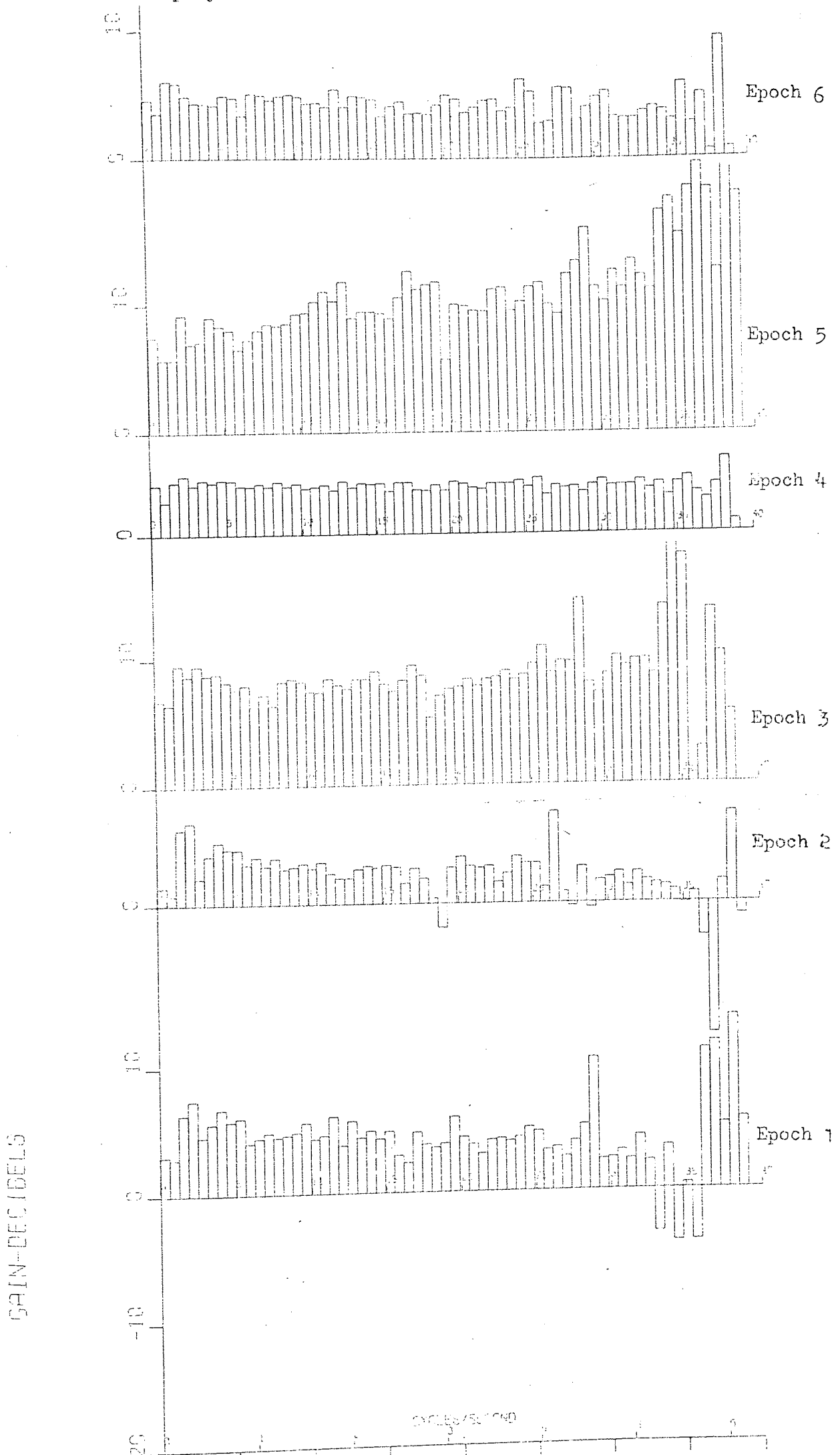

Figure 2.78 Auto Spectrum of Display movement.  
(subject KD, condition 'C')

G. D. WHITEHEAD

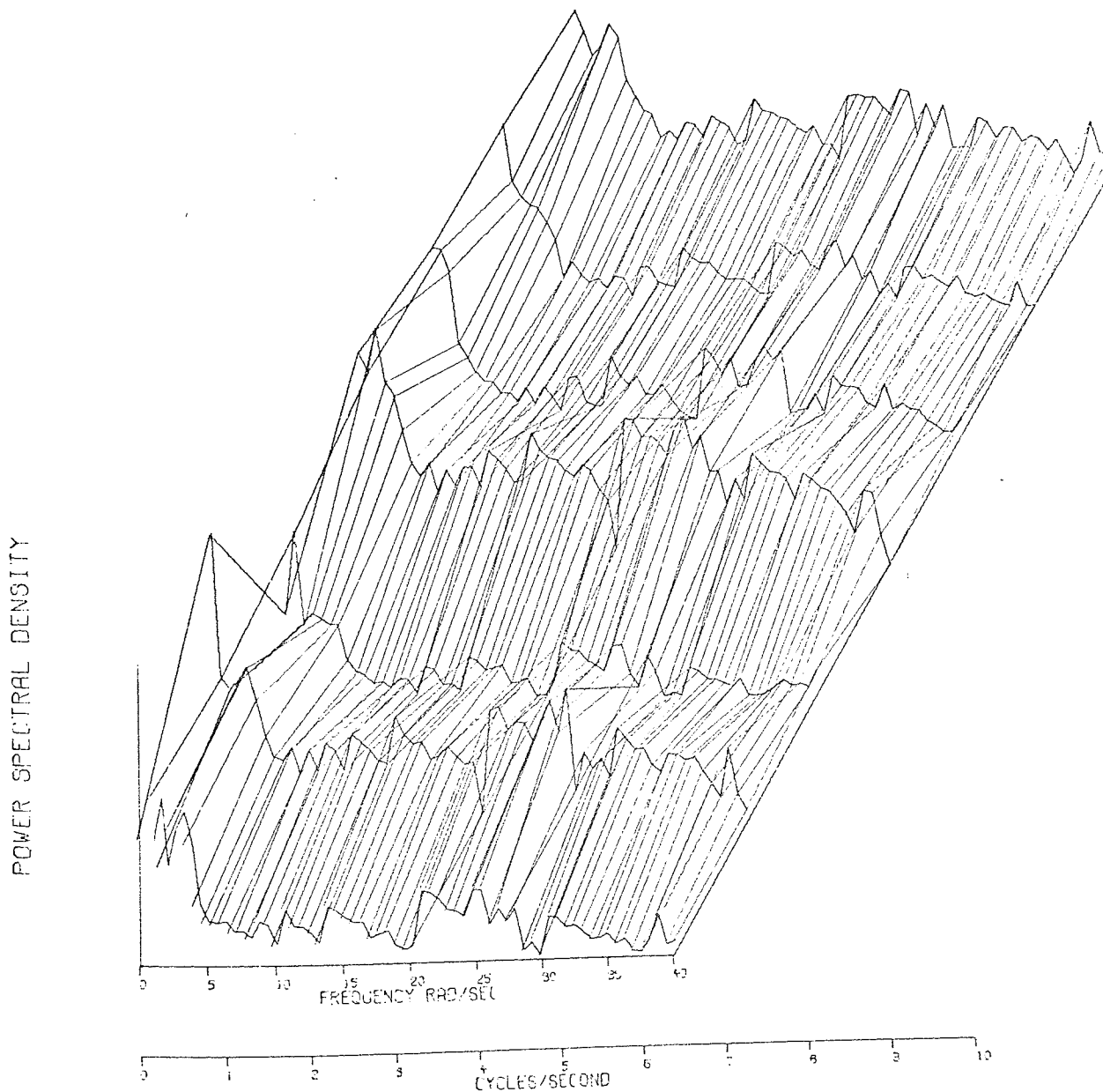

Figure 2,79 Auto Spectrum of Control movement.  
(subject KD, condition 'C')

G. D. WHITEHEAD

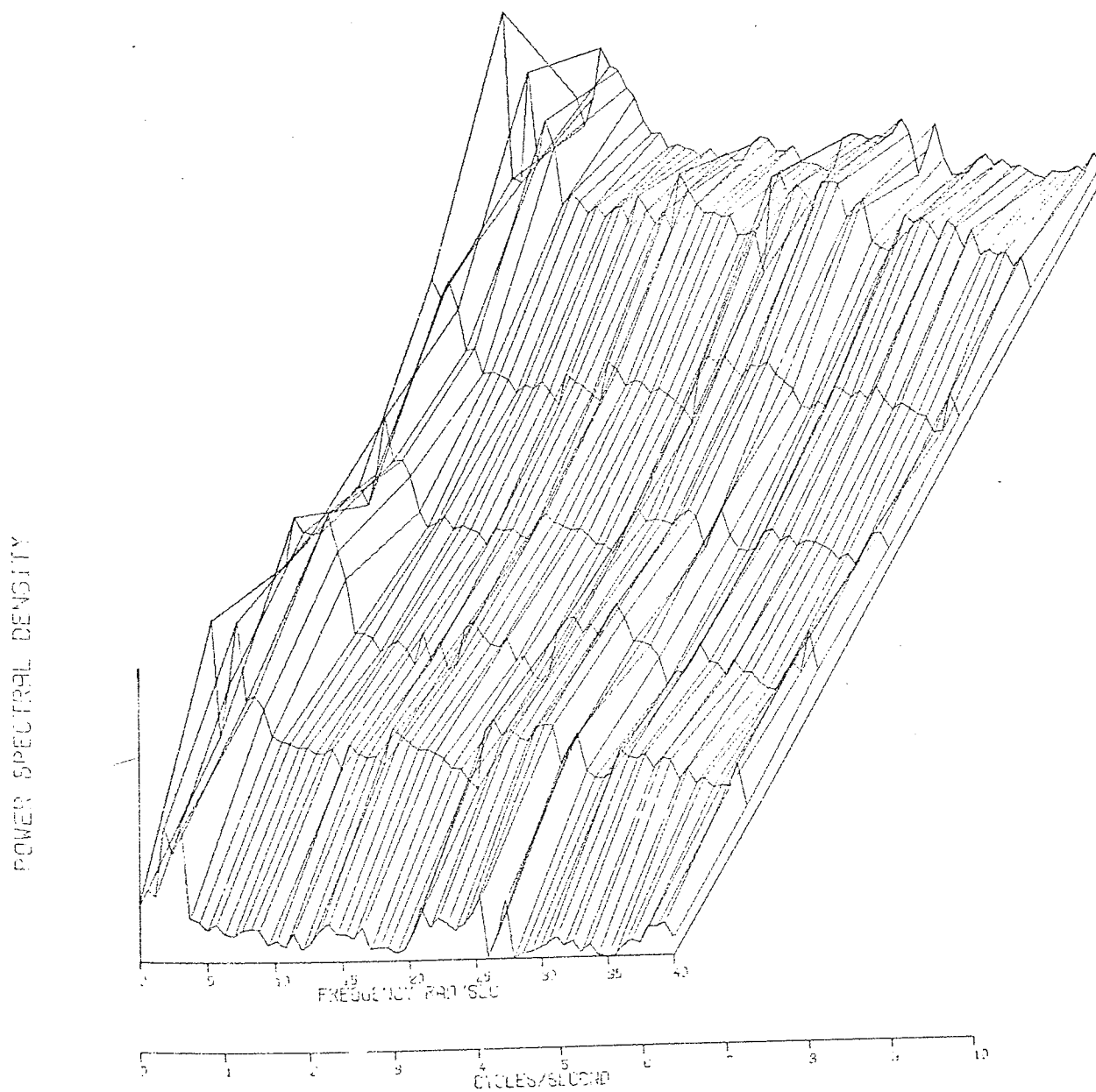

Figure 2.80 Cross Spectrum between  
Display & Control movement  
during Non Stationary Vibration  
(Subject KD, condition 'C')

G. D. WHITEHEAD

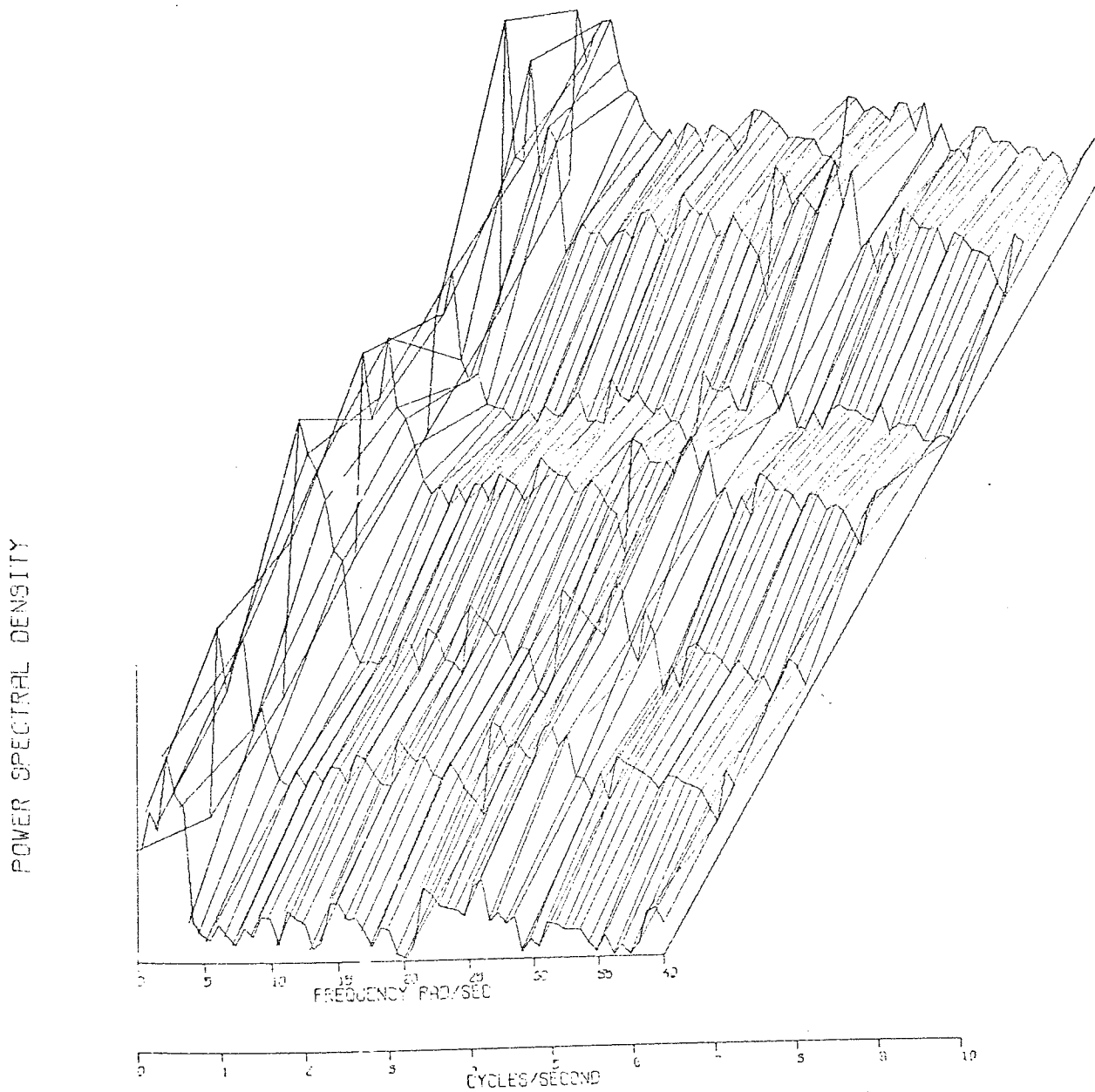
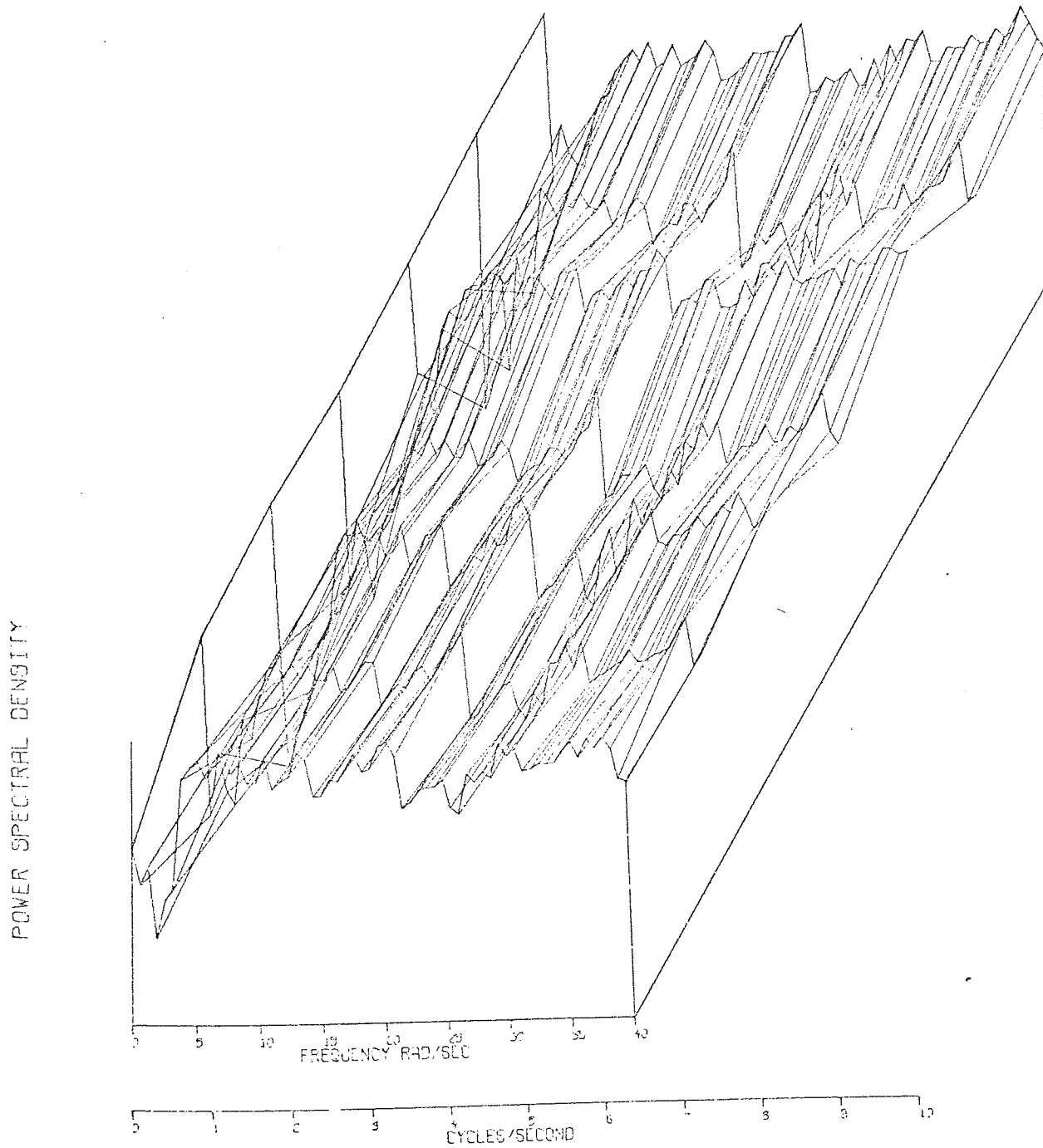

Figure 2.80a An Inverted view of fig 2.80. G. D. WHITEHEAD



difficulty index requires a concomitant fall in operator gain  $Y_p$  to retain stability. This in turn requires more delicate movement of the control with a resultant fall in the output power and therefore possible correlated power between error and control movement.

Subject R.M. - This subject was instructed to use the compensatory tracking criterion, which, because of the adaptive logic tended always to drive the element to a higher level of instability than was the case with the other criteria. A high index of difficulty implies high controlled element gain and a need for the operator to reduce his gain in order to compensate for the controlled element, see Fig.2.31. The behaviour of R.M. in this trial is a good example of adaptation to controlled element gain. Her gains during the trial, computed without reference to the input signal, shown in Fig.2.81. At the beginning of the trial, without vibration, her index of difficulty for the first epoch averages 5.0rads/sec. and her gain in the region of this frequency -2.5db. With the onset of vibration the task is made more difficult and her index falls to 4.2 and 3.7 rads/sec. in the 2nd. and 3rd. epochs respectively. The falls in gain are accompanied by increases in gain of 0db. and +2.5db. respectively. Peak vibration intensity which occurs in the 4th. analysis epoch, causes her index of difficulty to drop to 2.5rads/sec, but instead of raising her gain further the gain drops to 1.5db.. This suggests that the subject either could not cope with the vibration or alternatively that she had given up trying. After removal of the vibration the subject recovers rapidly, her gain increases to improve her difficulty score thereby compensating for the increased controlled element gain. The cross spectrum,  $G_{ec}$ , associated with these gains are shown in Fig.2.82. In the region of vibration (epochs 3 and 4) the cross power level rises markedly, the reason being that the error waveform amplitudes



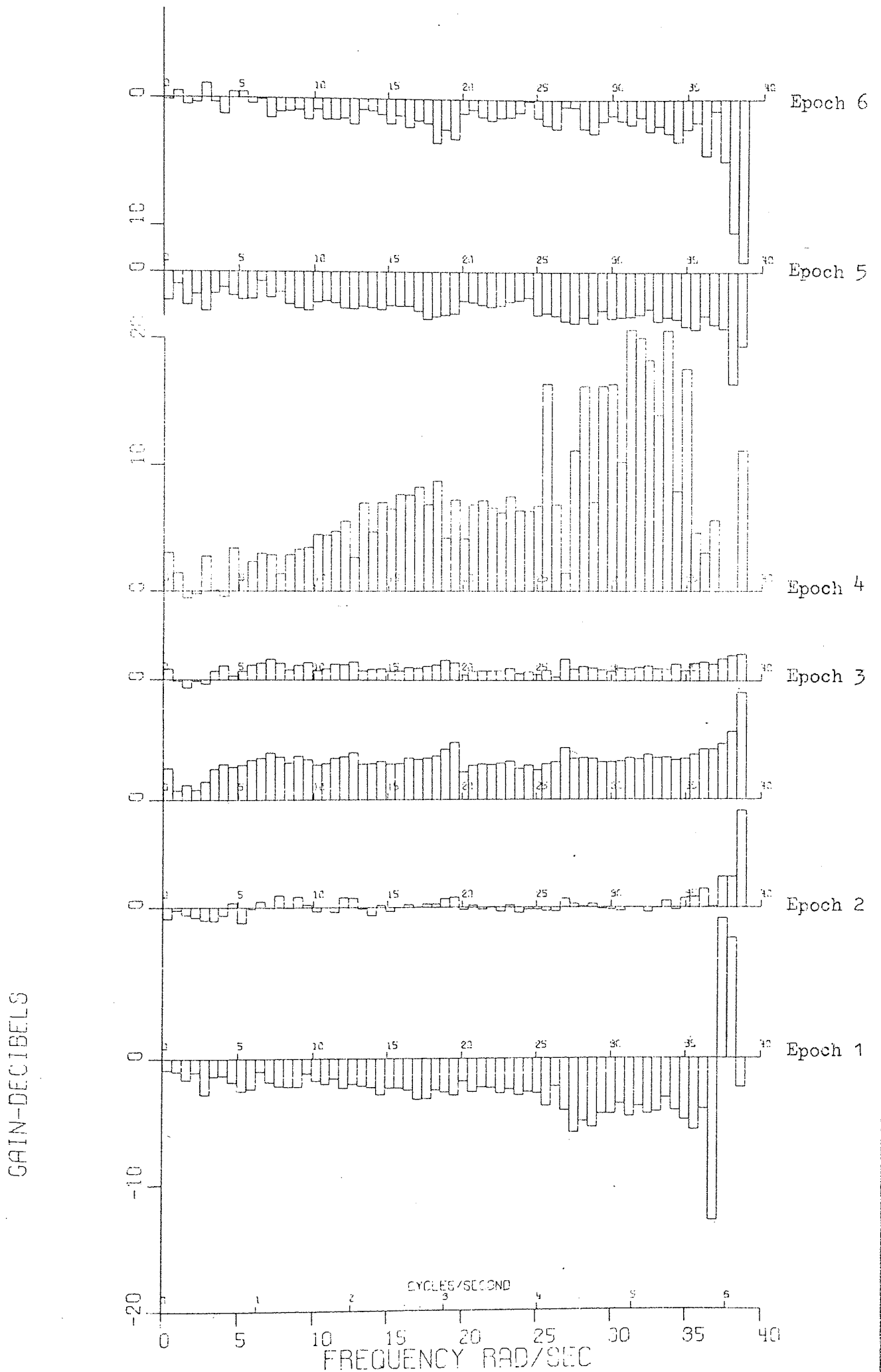

Figure 2.82 Cross Spectrum  $G_{ec}$  between C. D. WHITEHEAD  
Display & Control movement  
During Non Stationary Vibration  
(subject RM, condition 'A')

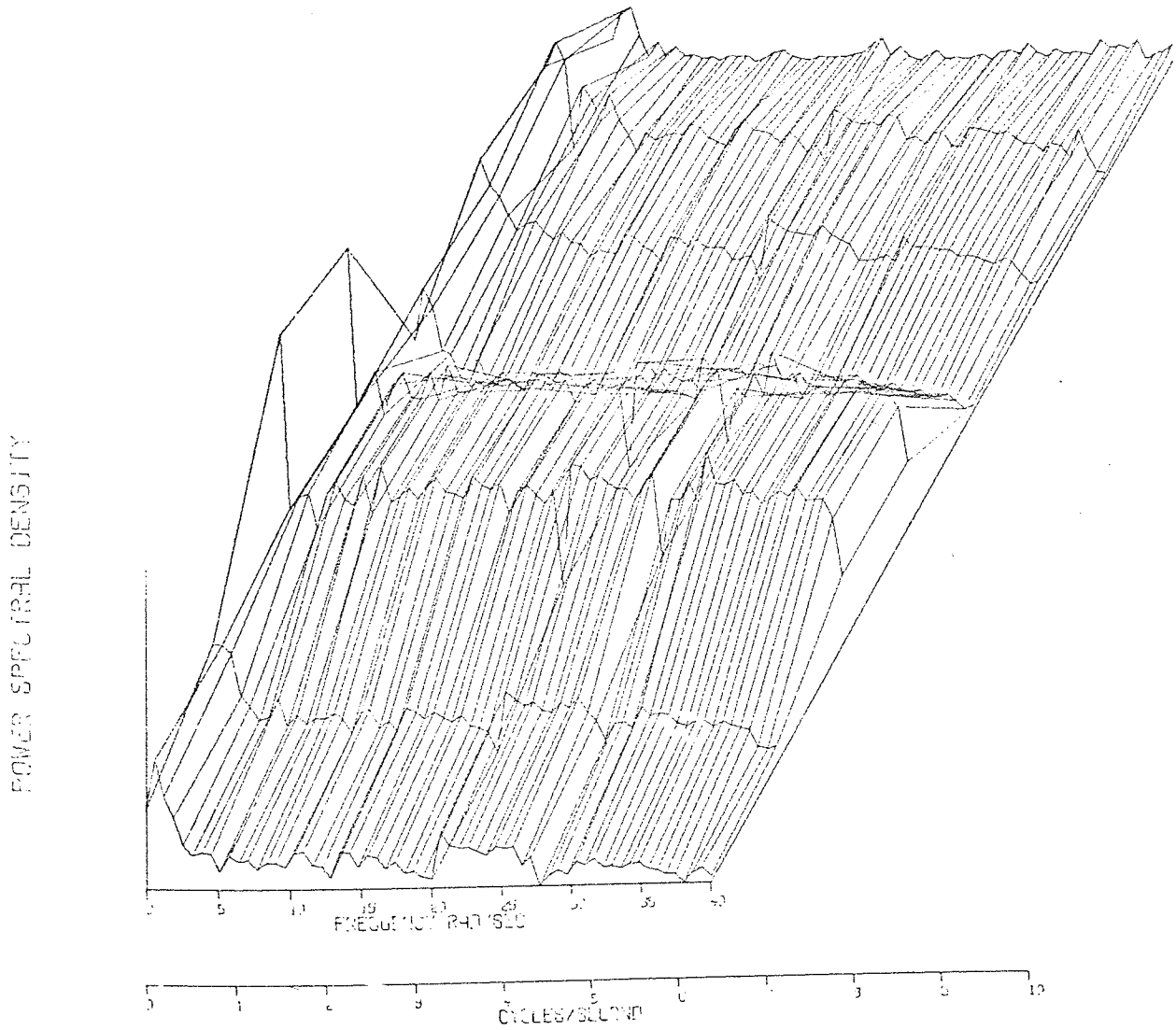
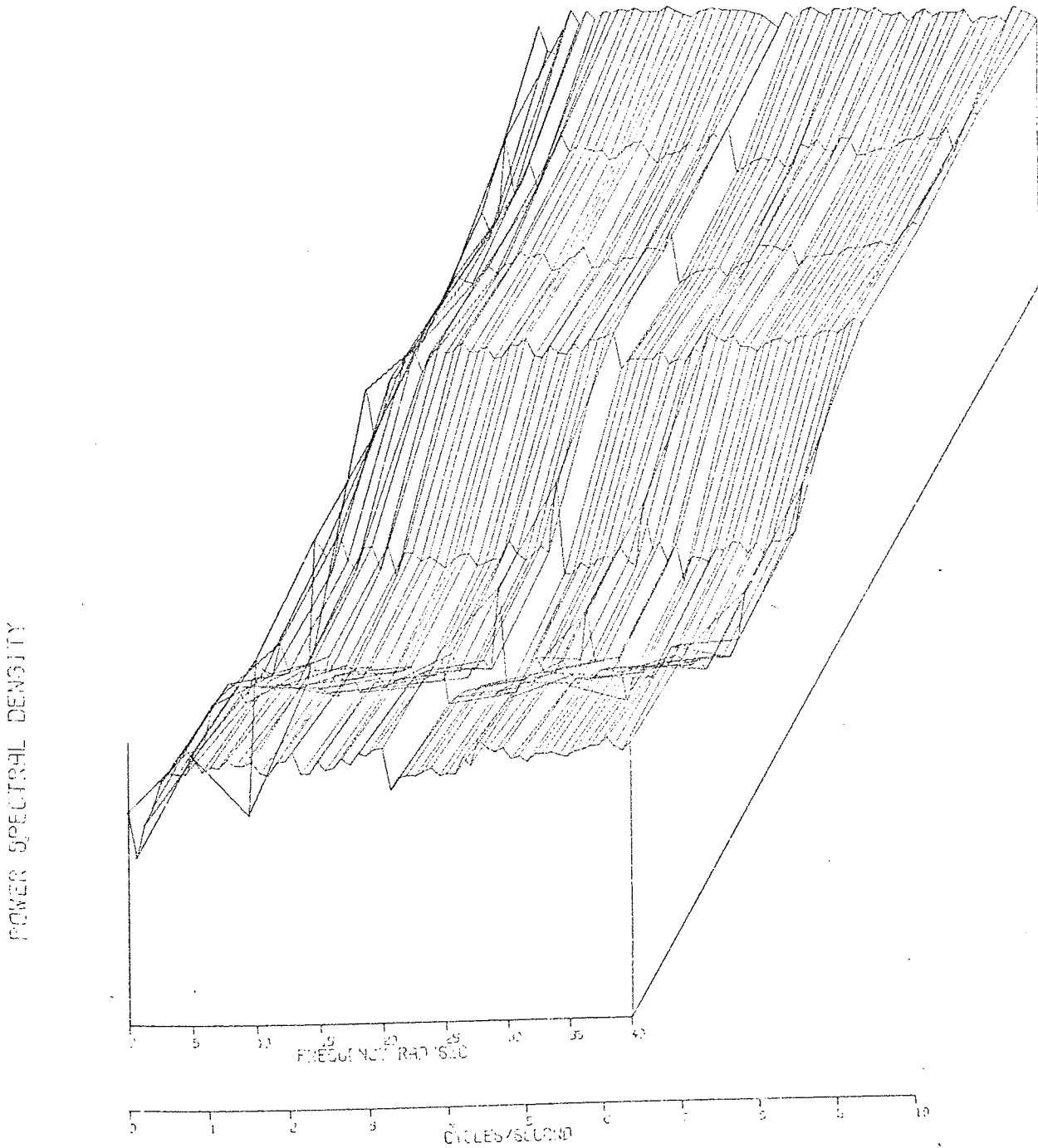

Figure 2.82a An Inverted view of fig.  
2.82

G. D. WHITEHEAD.



were greatest during these periods and to accompany the large line movement control actions were also enlarged thereby amplifying the power occurring jointly between error and control.

#### Phase Plane Analysis.

Power Spectral Density Analysis has provided insight into the nature of control behaviour sufficient to enable certain conclusions to be drawn concerning the causes and effects of vibration on the difficulty of the control task. For example it was shown that similar decrement in the index of difficulty during similar vibration exposures were caused on one occasion by a lack of effort and on another by excessively energetic control movement (subject T.H.). For subject K.D. PSD analysis revealed that onset of vibration gave rise to arousal or increased effort and that subject R.M., who was normally able to adapt her control function to changes in controlled element gain failed to do so when the vibration was intense.

As a check on the validity of the Phase Plane description detailed in Part I the same task waveforms were committed to phase plane analysis. In its present form phase plane analysis is comparable only to Auto Power Spectrum Analysis. No Cross PSD equivalent has yet been developed and so it is not yet possible to study stimulus-response behaviour using phase plane analysis.

A detailed example of the difference between phase plane and auto power spectrum analysis is shown in Fig.2.83. The analyses both refer to the same control action waveform. The subject at the same time was using the bang-bang control strategy with roughly one bang-bang hand movement cycle per

Comparison between Phase Plane & Power Spectrum Analysis.

PROBABILITY

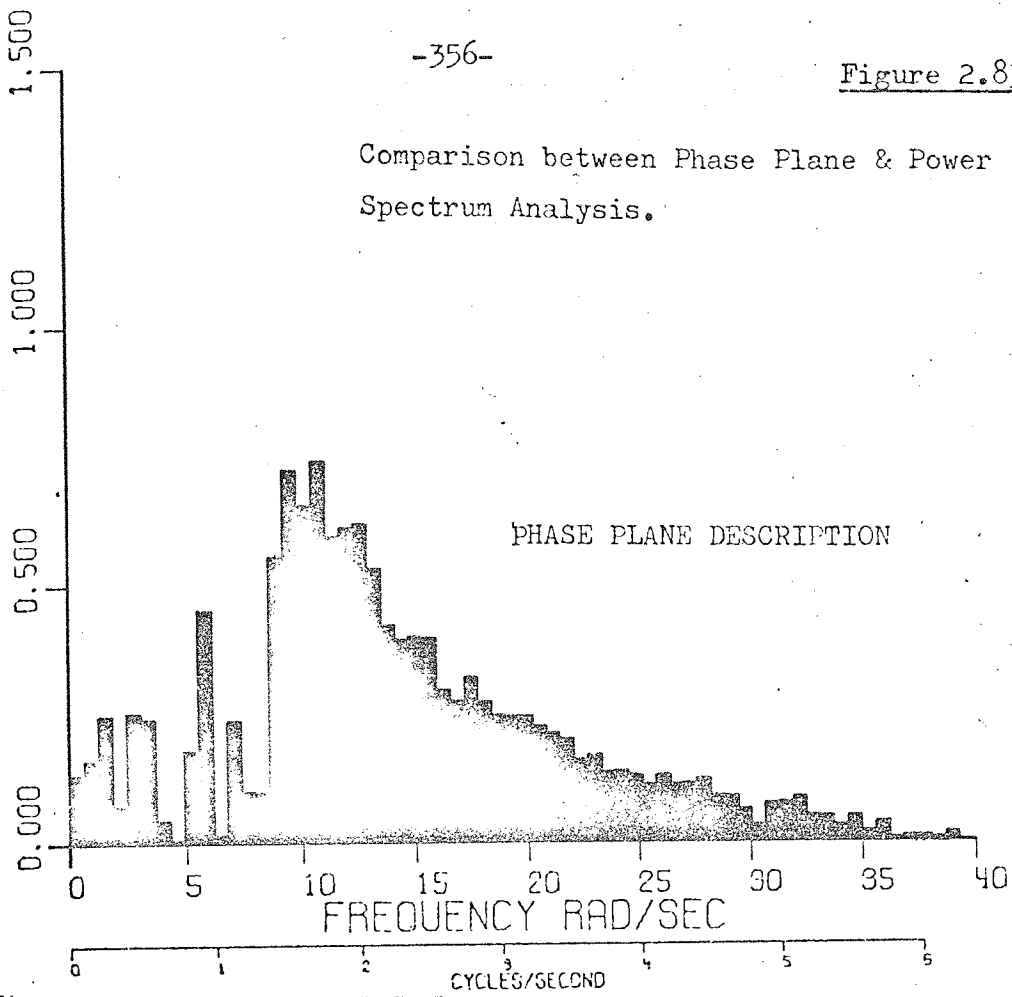

POWER SPECTRAL DENSITY

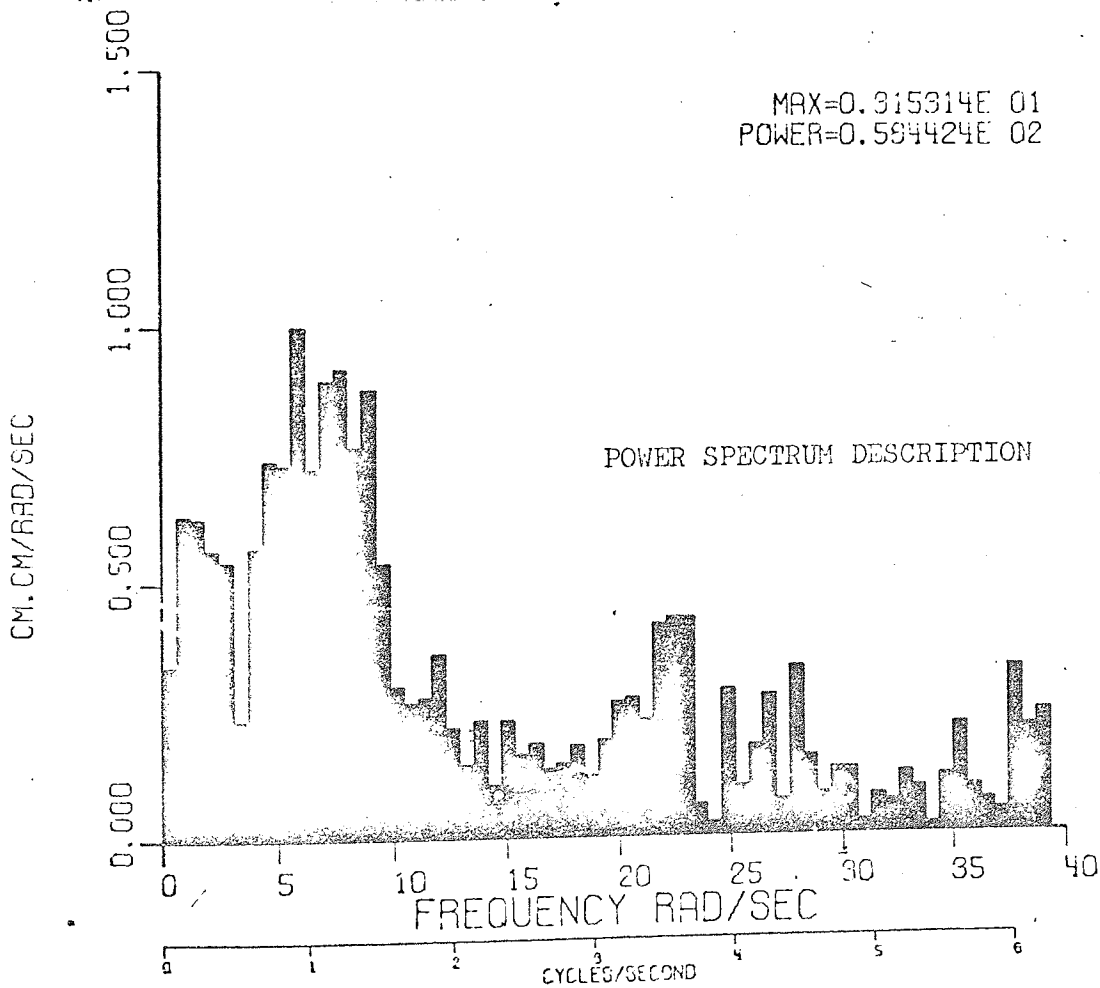

Figure 2.84

Phase Plane Description  
of Display movement to  
be compared with fig.2.72  
(subject TH)

G.D. WHITEHEAD

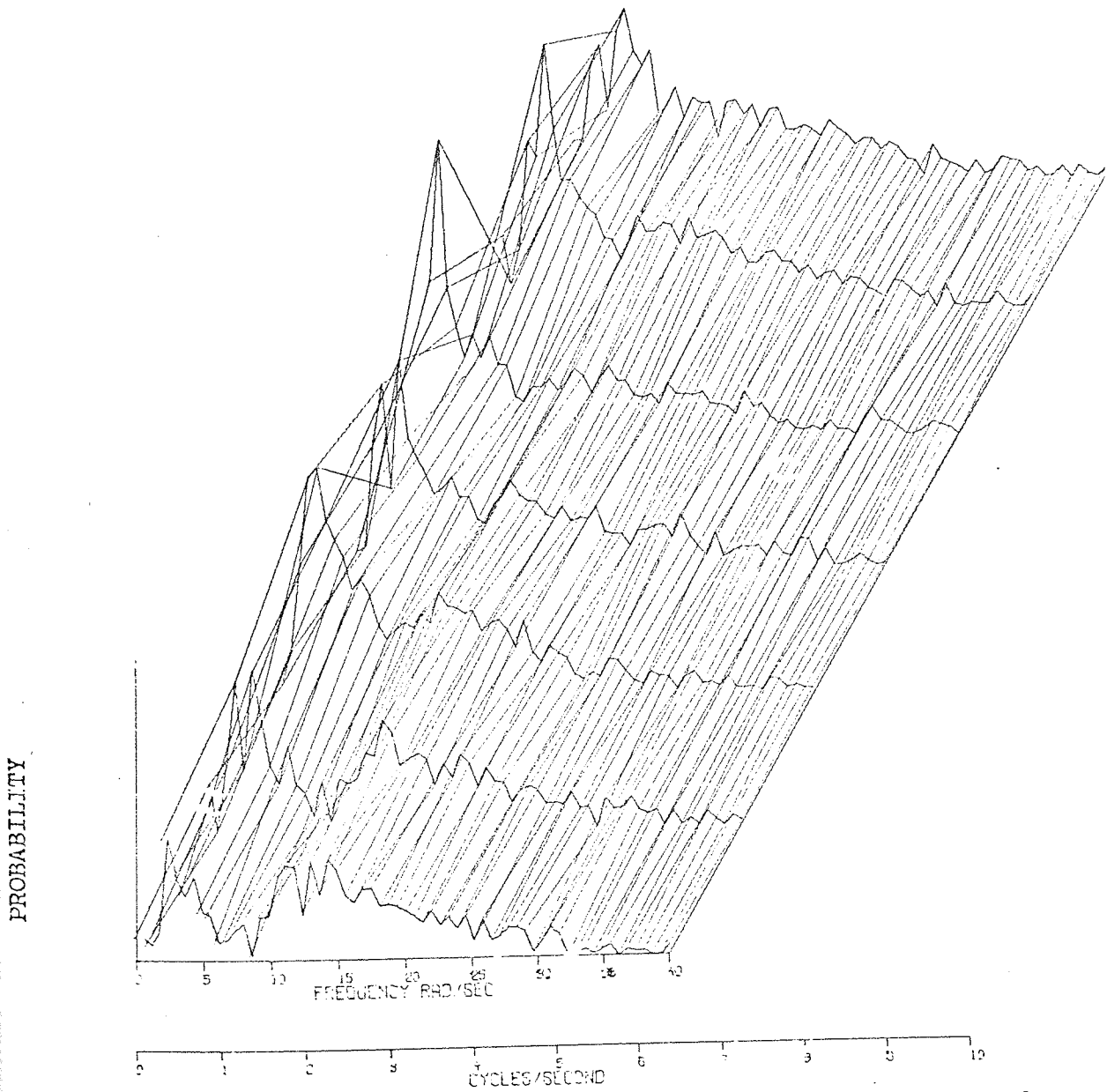

Figure 2.84a Fig. 2.84 Inverted

G.D. WHITEHEAD

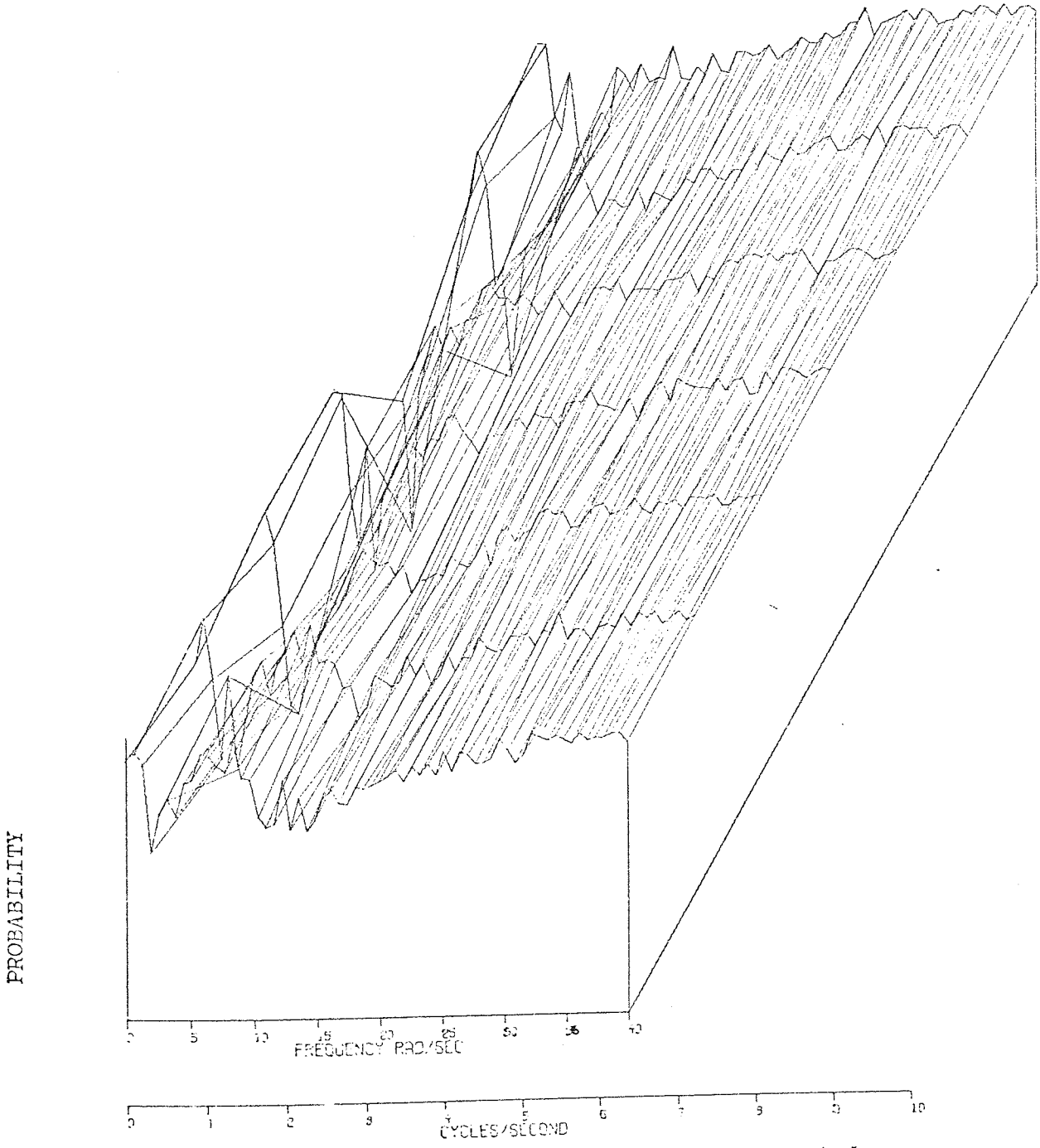

Figure 2.85 Phase Plane description  
of Control movement to  
be compared with fig 2.71.  
(subject TH)

G. D. WHITEHEAD

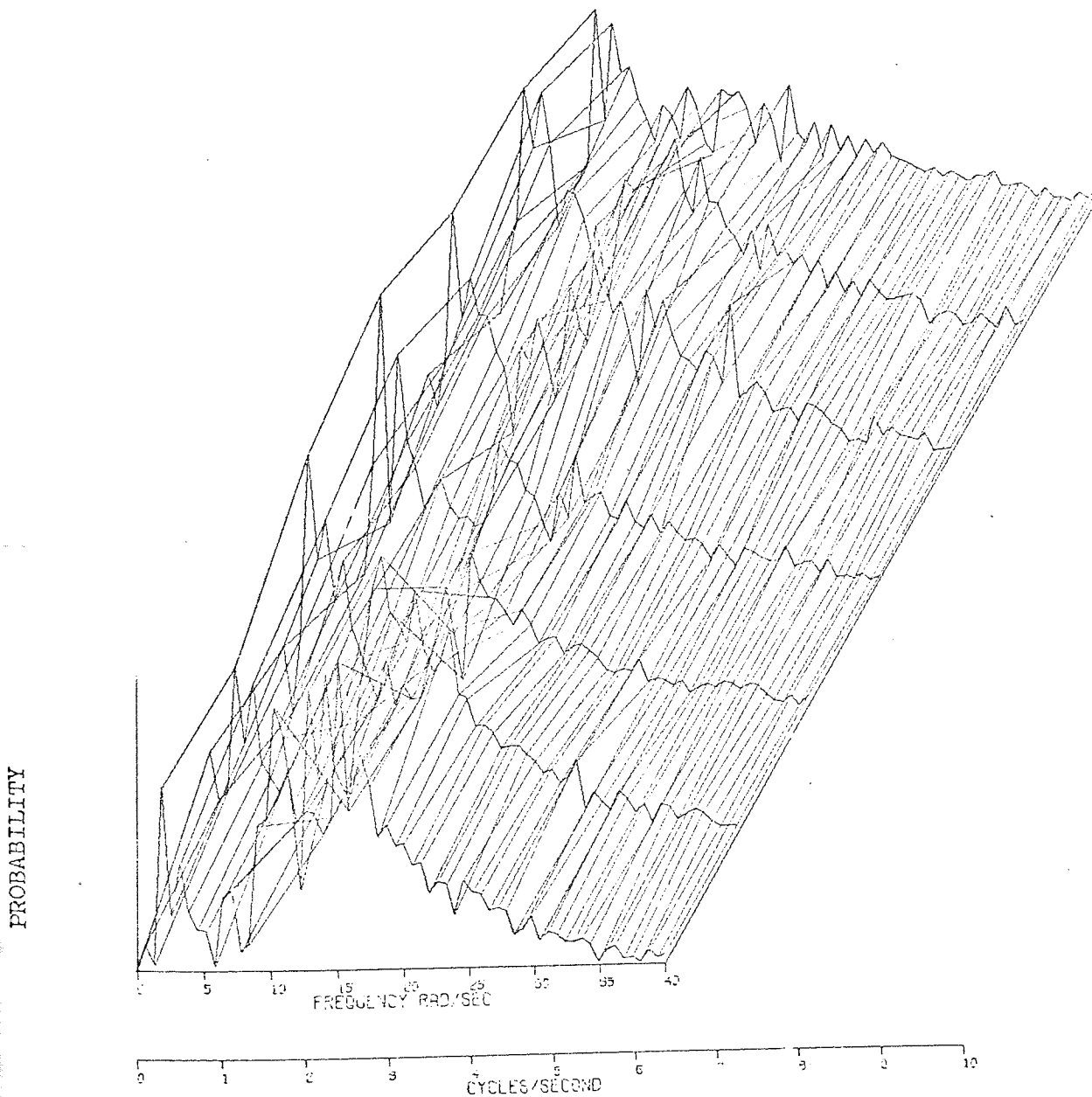
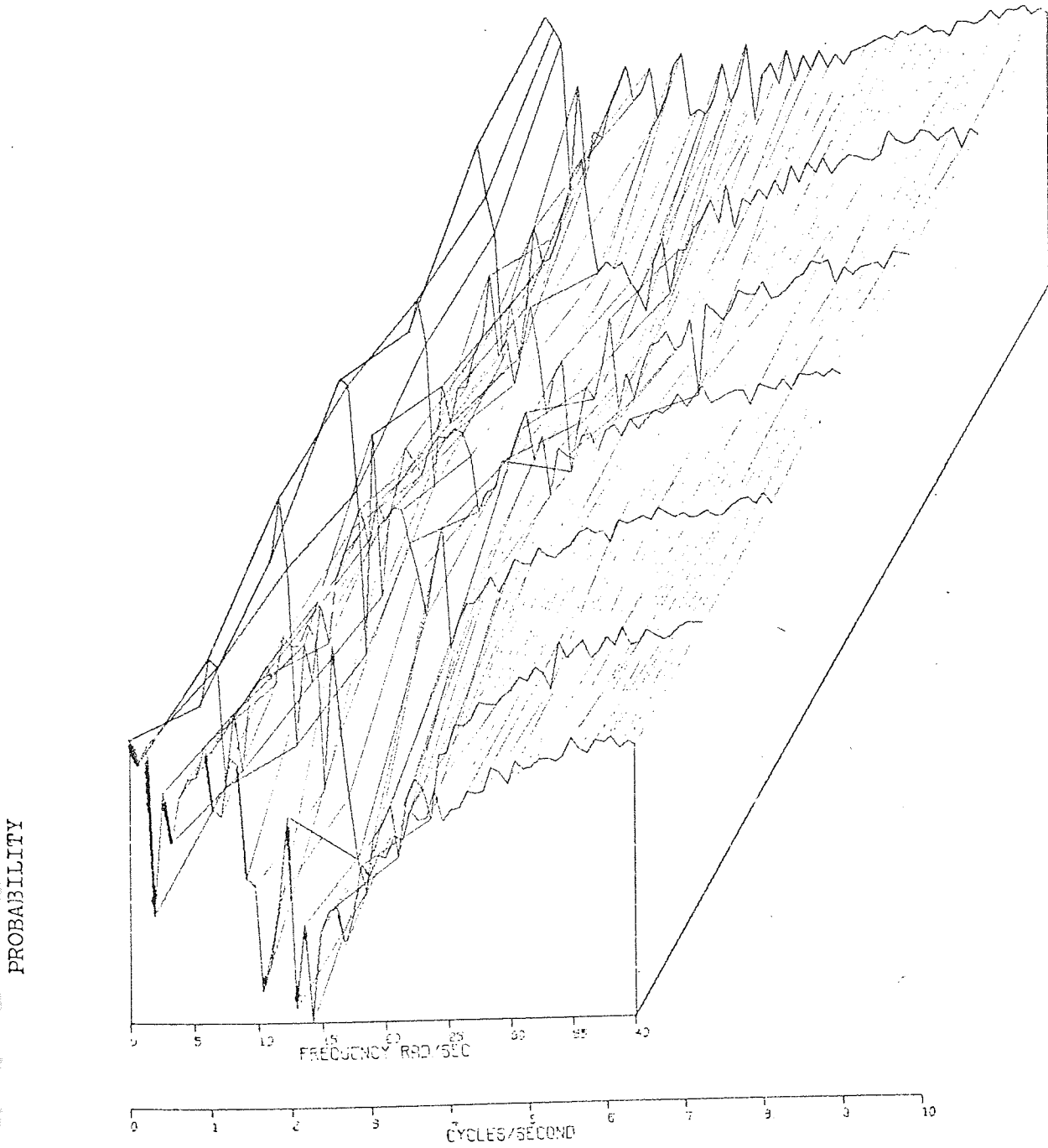



Figure 2.85a An Inverted view of  
fig.2.85

G. D. WHITEHEAD



second as indicated by the dominant peak in the PSD. The peak probability of angular velocity in the phase plane indicate a 'natural frequency' between 1.5 and 2.1Hz. (9-12rads/sec.). This upward shift of about 0.5-0.6Hz in the frequencies indicated by the phase plane analysis is a consistent factor which can be used to translate phase plane angular velocities into PSD frequencies.

Phase plane analysis of the error and control action waveforms for subjects T.H. are shown in Figs. 2.84 and 2.85. These are to be compared with the PSD results for the same waveform in Figs. 2.72 and 2.71 respectively. Compared to the PSD result for control actions the phase plane analysis shows the same fall in the abundance of hand movement at 6-12 rads/sec. in the PSD at the 4th. epoch followed by a rise in abundance at the 5th. epoch, The phase plane shows a greater abundance of hand movement in the region of input frequencies (0-6 rads/sec.) and a sharper division between this frequency band and the band above. In general, what trends there are in the PSD analysis, Fig.2.70, appear in the phase plane equivalent Fig.2.85. The error PSD, Fig.2.71 and its phase plane equivalent, Fig. 2.84 have less in common. In the PSD at 0-4 rads/sec., error power falls to a local minimum whilst in the phase plane it reaches a maximum. In general the trends contained in the PSD profile are not apparent in the phase plane surface.

For subject K.D. the phase plane analysis for error and control actions are shown in Fig. 2.86 and 2.87. The corresponding PSD's are Figs. 2.78 and 2.79. The PSD of control actions show no sign of there being a dominant hand movement frequency beyond the range of input frequencies, The phase plane is in agreement with this and with the general rise and fall in control movement power over the trial. Particularly noticeable, in the upside down

Figure 2.86 Phase Plane description  
of Display movement to  
be compared with fig.2.78  
(subject KD)

C. D. WHITEHEAD

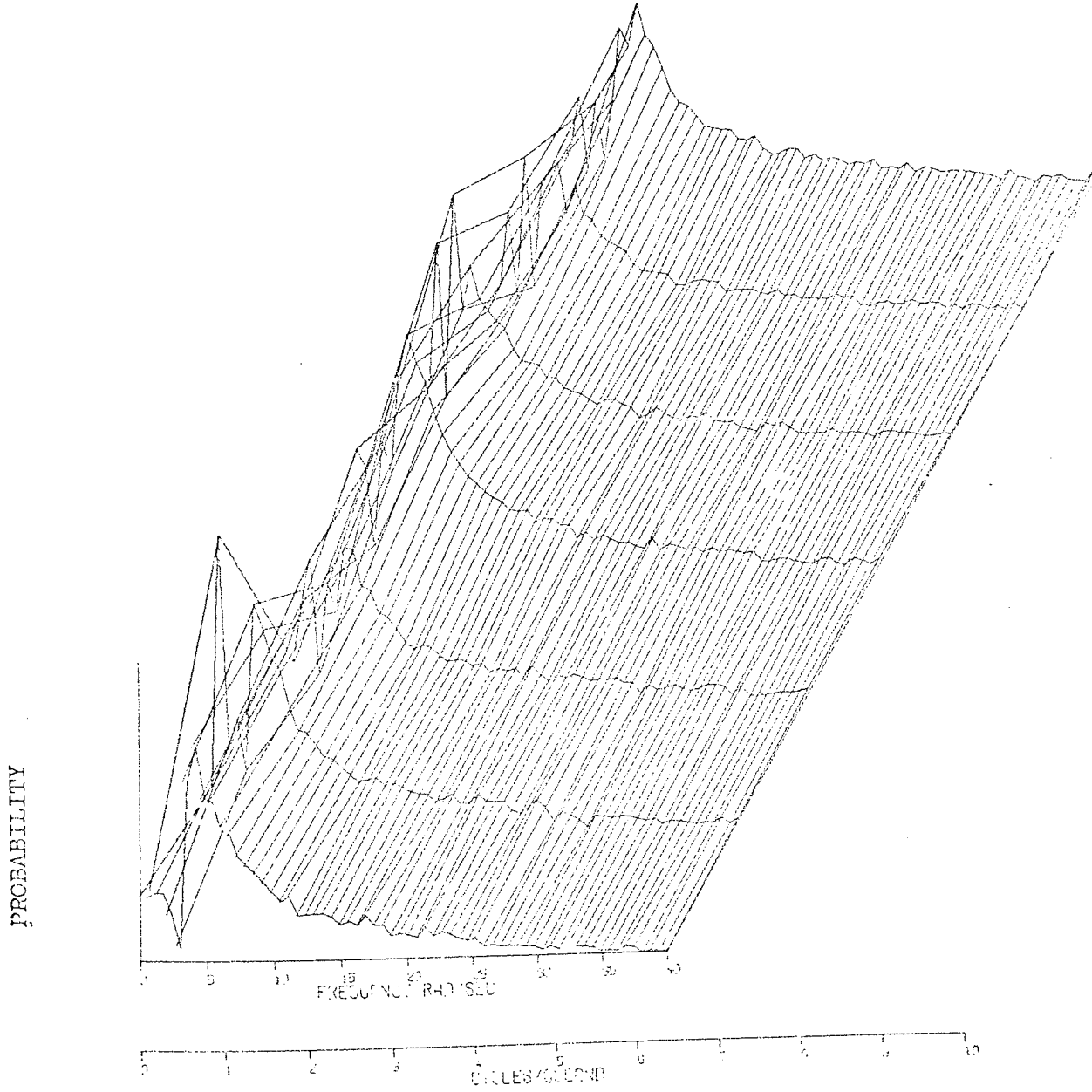

Figure 2.86a Fig.2.86 Inverted.

G. D. WHITEHEAD

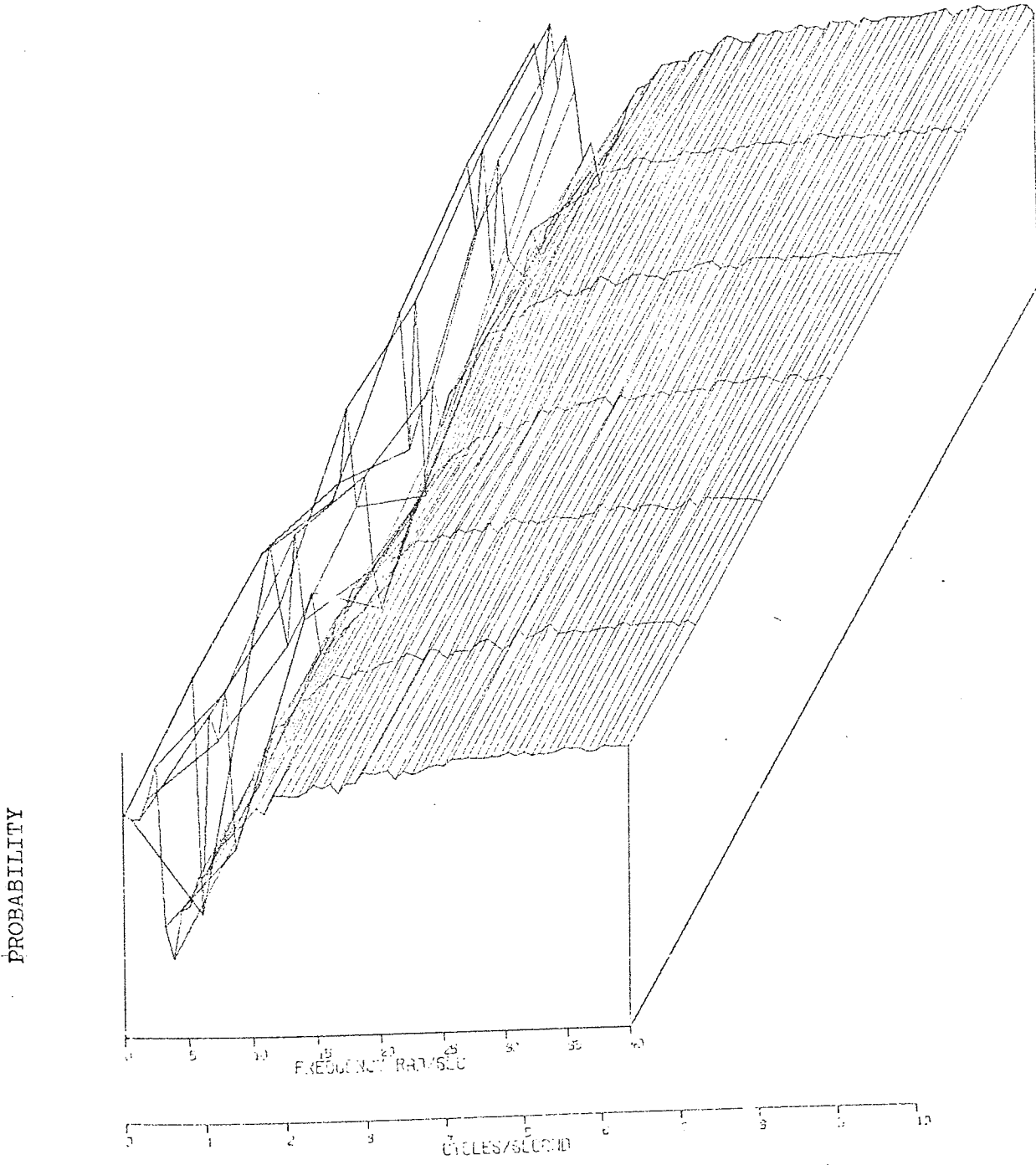

Figure 2.87

Phase Plane description  
of Control movement to  
be compared with fig.2.79  
(subject KD)

G. D. WHITEHEAD

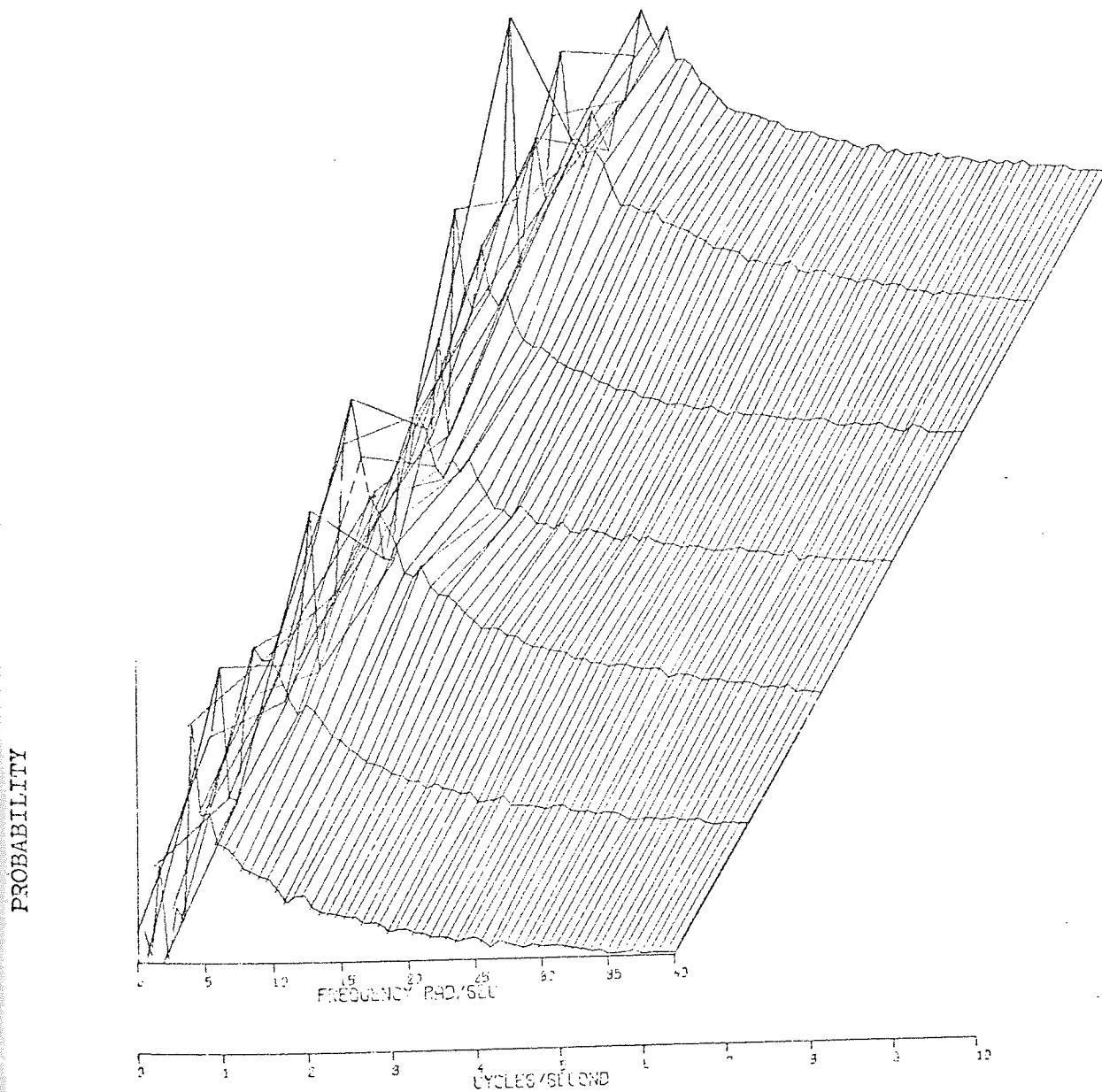
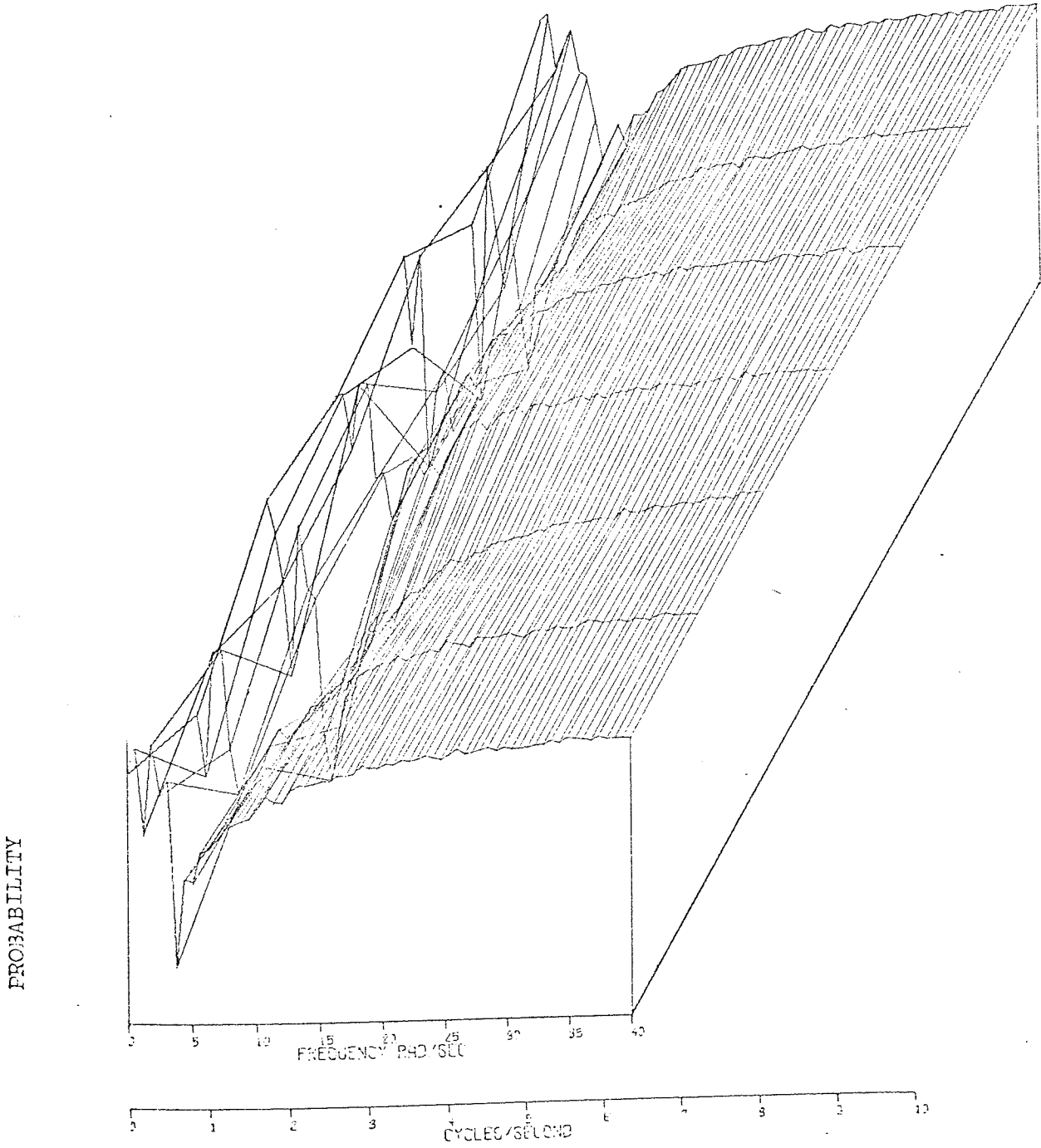

Figure 2.87a An Inverted view of fig 2.87.

G. D. WHITEHEAD



plot of the phase plane analysis, is the effect of vibration whose intensity was a maximum during the 3rd. and 4th. epoch. The corresponding results for the error waveform analysis show a similar pattern of ups and downs in the region of input frequency.

Clearly this rather brief check on the phase plane description is no proof of its validity, or otherwise, as a replacement for PSD analysis. In three out of the four examples presented there was good agreement. In one case it was in violent disagreement. Compared to PSD the relative frequency of angular velocities in the phase plane is a fundamentally different measure. It is a visible property of the waveform unlike PSD which is a transform and it is independent of amplitude. It was thus no surprise to find disagreement between the two descriptions but quite a surprise that it agreed so well in other analyses. The conclusion regarding phase plane analysis must therefore be cautionary but further development and use should be encouraged. It has the advantage of computational simplicity and therefore speed. Computation time relative to the slow Fourier Transform used to calculate PSD was about  $1/20$ th. Compared to a fast Fourier Transform which takes about  $1/10$ th. the time of the slow version it is twice as fast - a consideration worth bearing in mind when there is a need to perform real time frequency analysis on a small computer. Before it is abandoned the technique should be further examined and use made of its ability to separate frequency from amplitude. It is thought that disagreement between the PSD and phase plane, when it occurred, was due to an interaction effect between amplitude and frequency. The PSD indicated a drop in power whilst the phase plane indicated an increase in the relative frequency of frequencies in the same frequency band. For the same waveform this is a feasible effect because it is possible for an angular velocity to occur often in the phase

Measured Acceleration Amplitude  
Probability Density at the Subject/  
Seat Interface. RMS 'g' = 0.09.

Figure 2.88

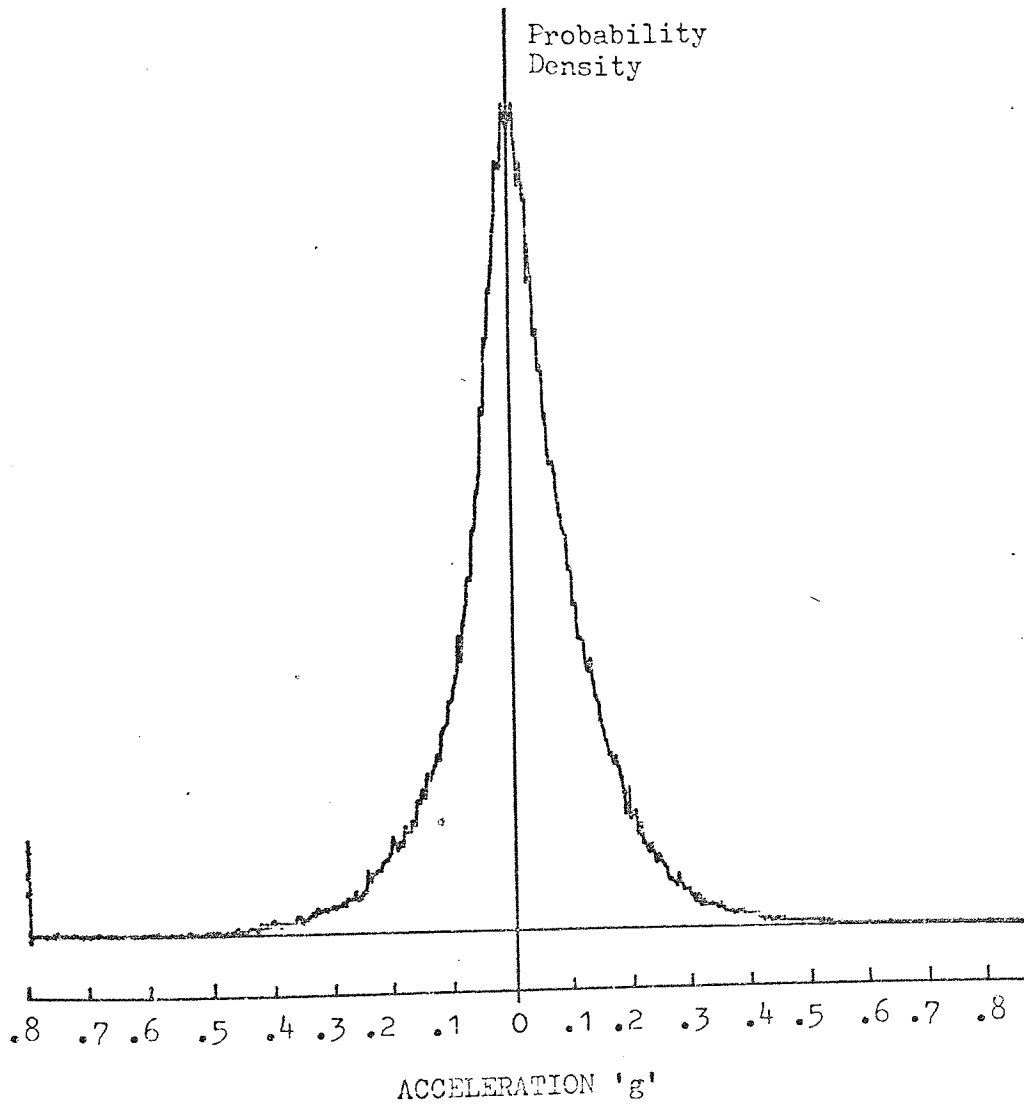



plane at zero or near zero amplitude. Thus there is a dimension (amplitude) missing from the phase plane description which is included in the PSD.

### 2,6.12.3. Vibration.

An analysis of vibration records obtained during stationary vibration trials (condition D) was carried out for each of the subjects whose task waveforms were analysed above. During their stationary vibration trials these four subjects were each tested up to the maximum vibration intensity of 0.09Rms'g' and their associated indices of task difficulty are shown in Fig. 2.38.

The levels of random vibration during these trials were 0.015, 0.03, 0.045, 0.06, 0.075 and 0.09Rms'g', as measured at the subject/seat interface.

Acceleration records were obtained for vertical vibration at the subject/seat interface and head and for lateral vibration (in the direction of control movement ) at the control box. The analysis carried out on these records was similar to that for the task variables but the results are presented as the average for the four subjects rather than individually, and the results are restricted to the four highest levels of vibration.

At all levels of vibration the Amplitude Probability Density contour was the same both at the head and at the subject/seat interface. An example at the subject/seat interface at 0.09Rms'g' is shown in Fig.2.88. Figs.2.89-2.94 are examples of the detailed spectrum analysis carried out at each of the four vibration levels. The example shown refers to the 0.06Rms'g' level. They are respectively  $G_{SS}$ , the Subject/Seat Auto Spectrum, the Head Auto Spectrum  $G_{HH}$ , the Seat/Head Cross Spectrum  $G_{SH}$ , the Seat/Head Cross

# FOURIER/HANNING TRANSFORM

G. D. WHITEHEAD

Figure 2.89

Autocorrelogram  $R_{SS}$  & Auto  
Spectrum  $G_{SS}$  of Acceleration  
at Seat

$R(0) = 0.514449E 06$

$R(INF) = 0.511515E 06$

(Seat RMS 'g' = 0.045)

AUTOCORRELATION COEFFICIENT

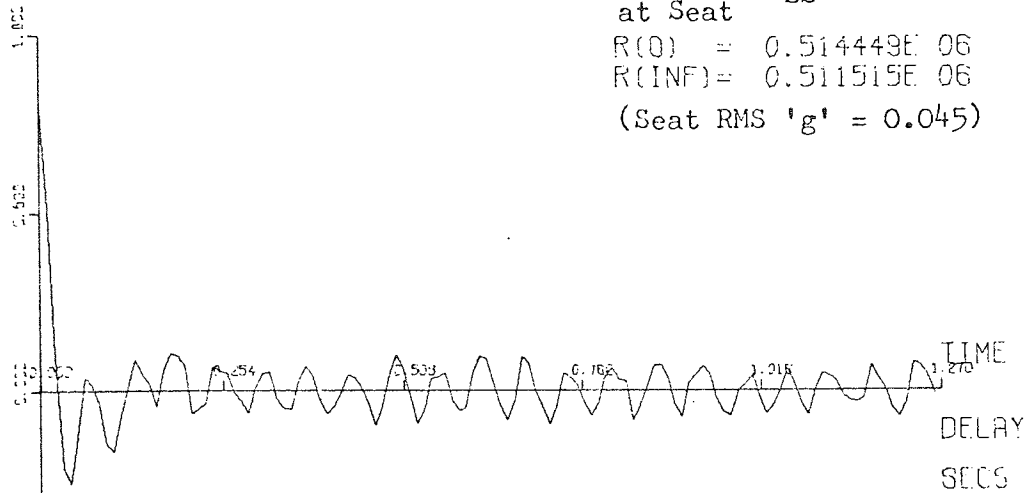

POWER SPECTRAL DENSITY

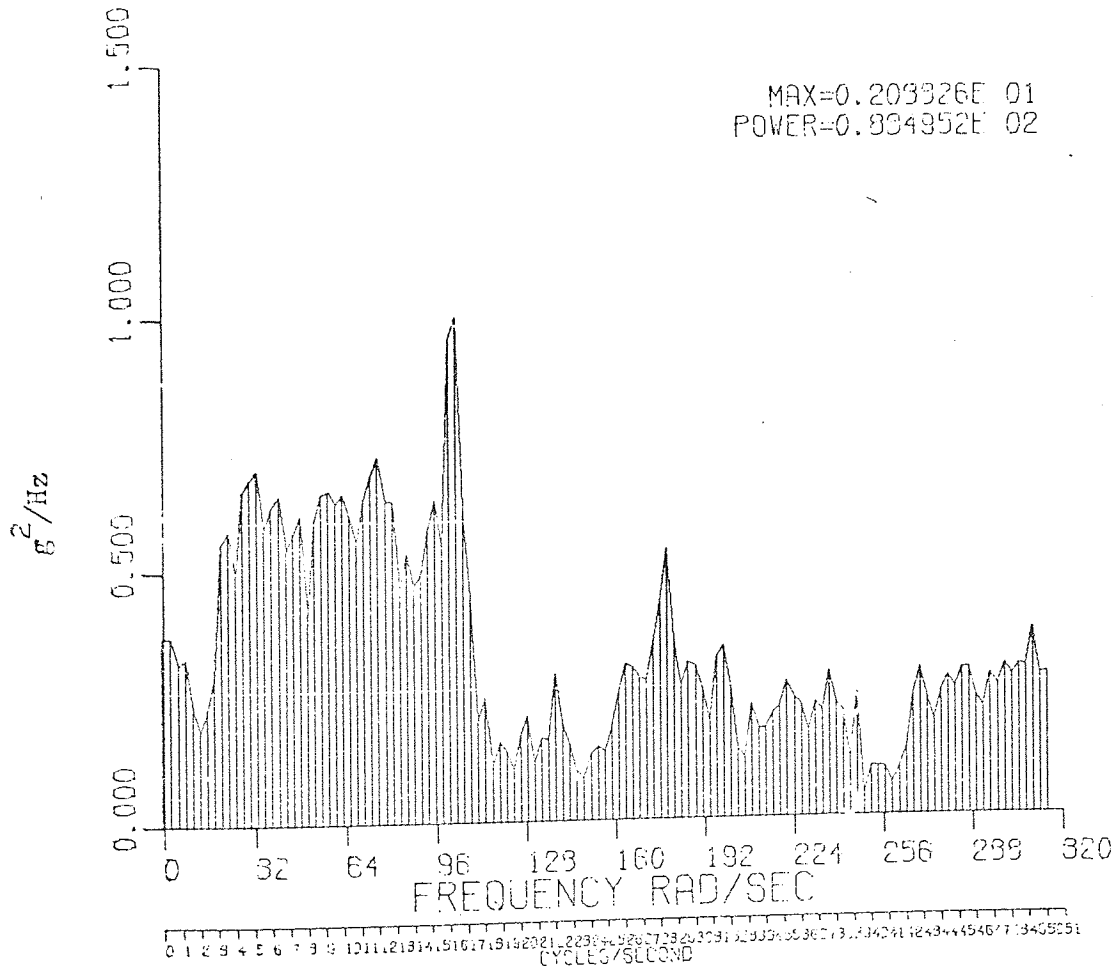

MAX=0.203326E 01  
POWER=0.304952E 02

# FOURIER/HANNING TRANSFORM

G. D. WHITEHEAD

Figure 2.90

Head Acceleration Auto-correlogram  $R_{HH}$  & Auto Spectrum  $G_{HH}$ .

$R(0) = 0.513652E 08$   
 $R(INF) = 0.511228E 08$

( Seat RMS 'g' = 0.045 )

AUTOCORRELATION COEFFICIENT

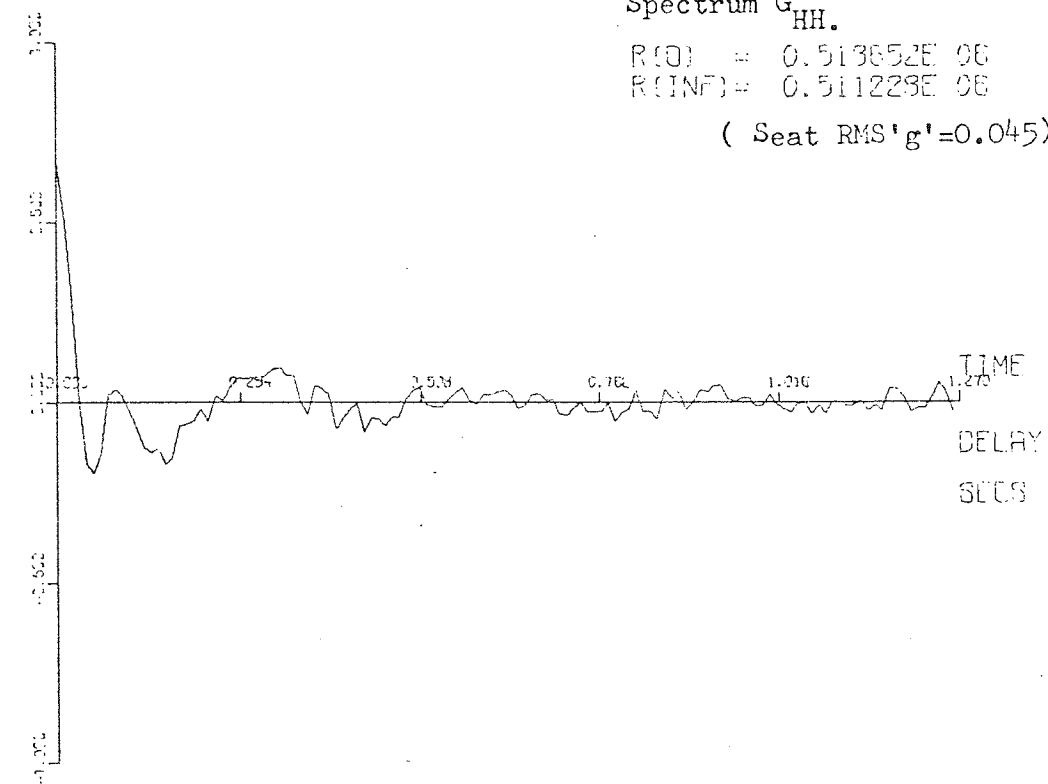

POWER SPECTRAL DENSITY

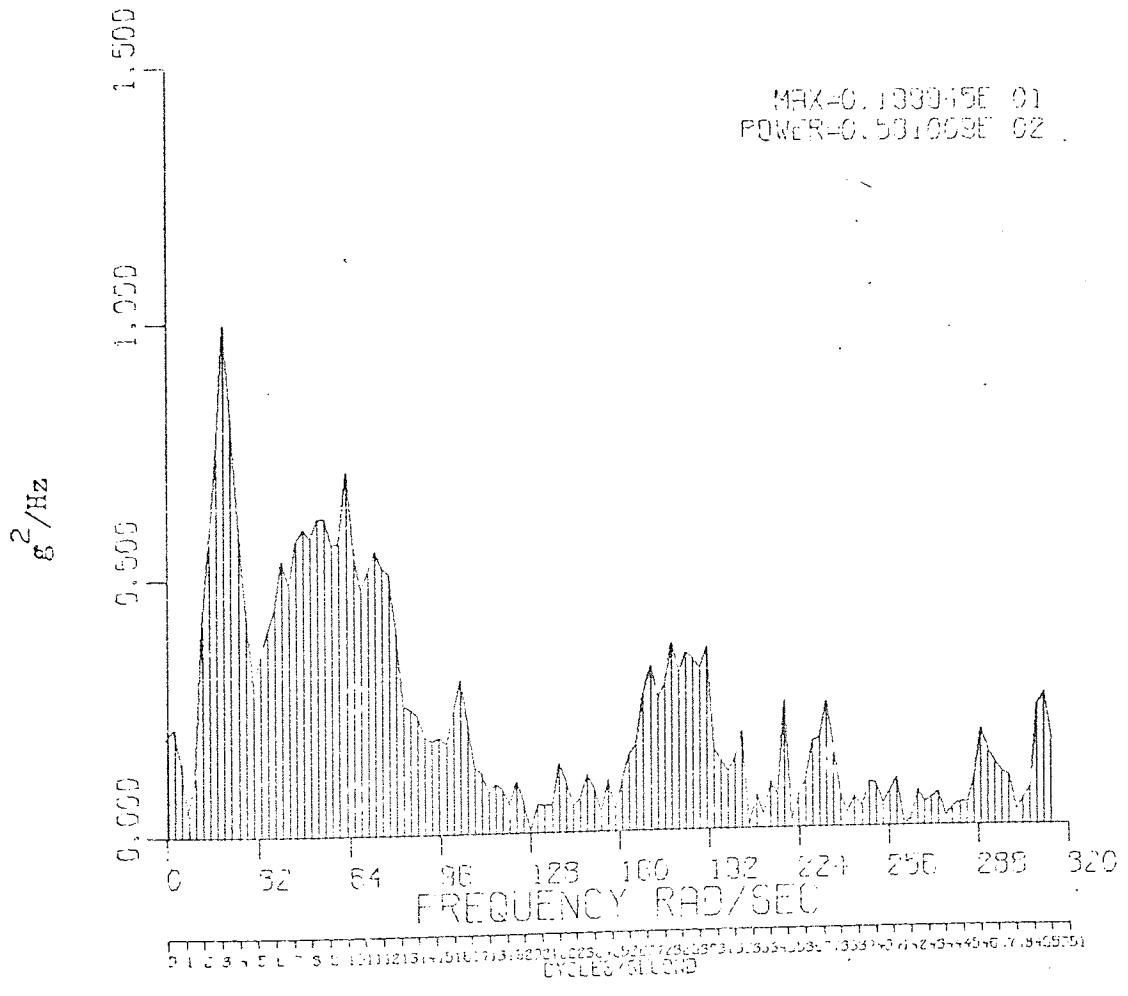

MAX=0.133945E 01  
POWER=0.531098E 02

0 1 2 3 4 5 6 7 8 9 10 11 12 13 14 15 16 17 18 19 20 21 22 23 24 25 26 27 28 29 30 31 32 33 34 35 36 37 38 39 40 41 42 43 44 45 46 47 48 49 50 51 52 53 54 55 56 57 58 59 60 61 62 63 64 65 66 67 68 69 70 71 72 73 74 75 76 77 78 79 80 81 82 83 84 85 86 87 88 89 90 91 92 93 94 95 96 97 98 99 100 101 102 103 104 105 106 107 108 109 110 111 112 113 114 115 116 117 118 119 120 121 122 123 124 125 126 127 128 129 130 131 132 133 134 135 136 137 138 139 140 141 142 143 144 145 146 147 148 149 150 151 152 153 154 155 156 157 158 159 160 161 162 163 164 165 166 167 168 169 170 171 172 173 174 175 176 177 178 179 180 181 182 183 184 185 186 187 188 189 190 191 192 193 194 195 196 197 198 199 200 201 202 203 204 205 206 207 208 209 210 211 212 213 214 215 216 217 218 219 220 221 222 223 224 225 226 227 228 229 230 231 232 233 234 235 236 237 238 239 240 241 242 243 244 245 246 247 248 249 250 251 252 253 254 255 256 257 258 259 260 261 262 263 264 265 266 267 268 269 270 271 272 273 274 275 276 277 278 279 280 281 282 283 284 285 286 287 288 289 290 291 292 293 294 295 296 297 298 299 300 301 302 303 304 305 306 307 308 309 310 311 312 313 314 315 316 317 318 319 320

# FOURIER/HANNING CROSS SPECTRAL DENSITY ANALYSIS

G. D. WHITEHEAD

Figure 2.91

Cross Spectra  $C_{SH}$  &  $Q_{SH}$

between Seat and Head  
Vibration.

( Seat RMS 'g' = 0.045 )

CO SPECTRUM

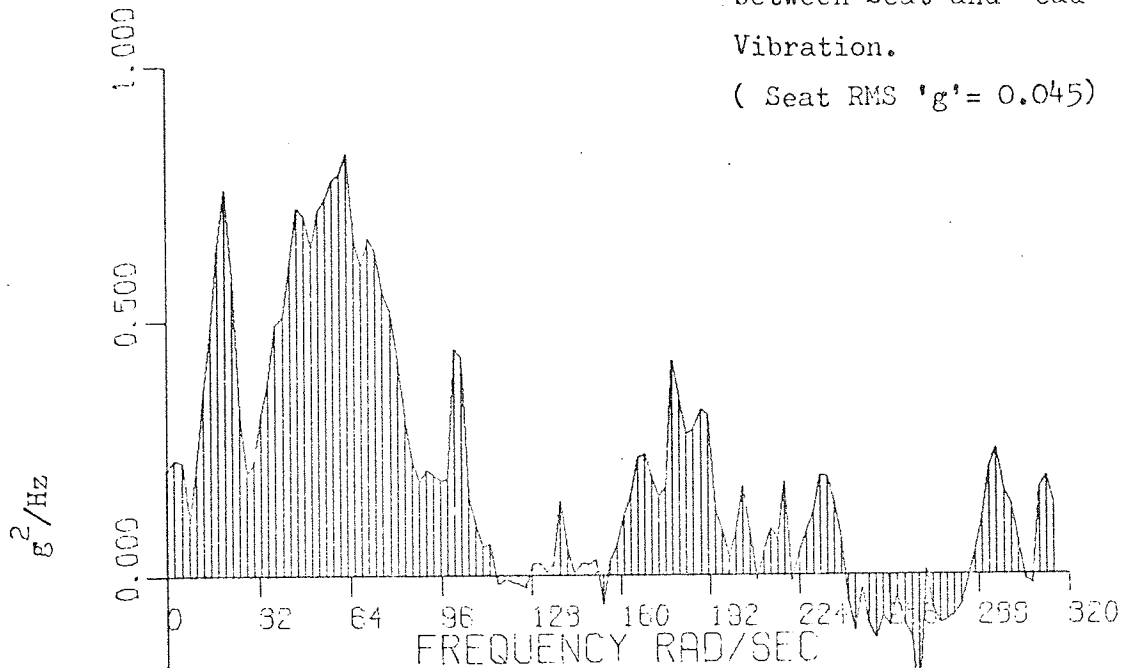

CYCLES/SECOND  
0 1 2 3 4 5 6 7 8 9 10 11 12 13 14 15 16 17 18 19 20 21 22 23 24 25 26 27 28 29 30 31 32 33 34 35 36 37 38 39 40 41 42 43 44 45 46 47 48 49 50

QUAD SPECTRUM

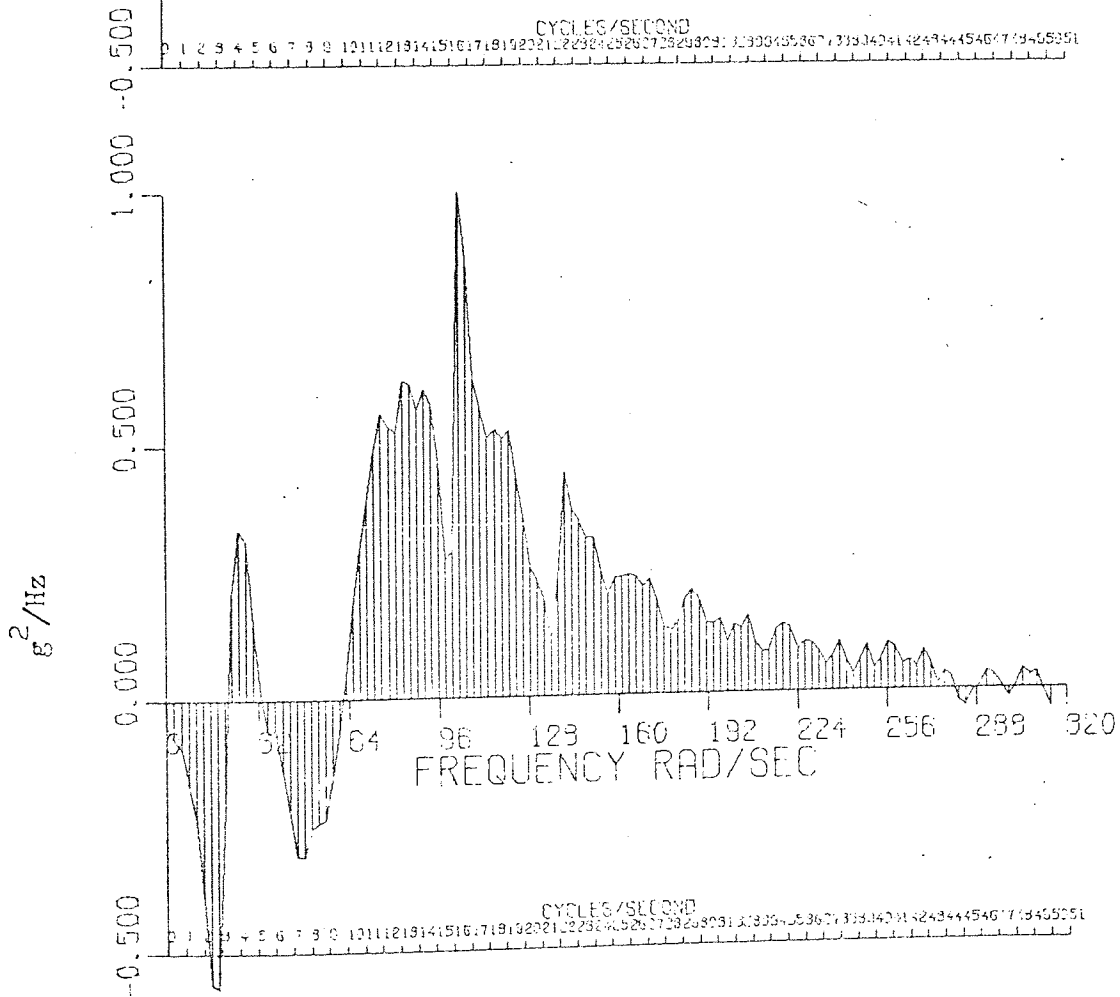

CYCLES/SECOND  
0 1 2 3 4 5 6 7 8 9 10 11 12 13 14 15 16 17 18 19 20 21 22 23 24 25 26 27 28 29 30 31 32 33 34 35 36 37 38 39 40 41 42 43 44 45 46 47 48 49 50

FOURIER/HANNING CROSS  
SPECTRAL DENSITY ANALYSIS

G.D. WHITEHEAD

Figure 2.92

MAX= 0.331197E 01

Crosscorrelogram  $R_{SH}$  &  
Kennedy-Pancu diagram of  $C_{SH}$   
&  $Q_{SH}$  for Vibration between  
Seat & Head.

(RMS 'g' = 0.045)

CROSSCORRELATION COEFFICIENT

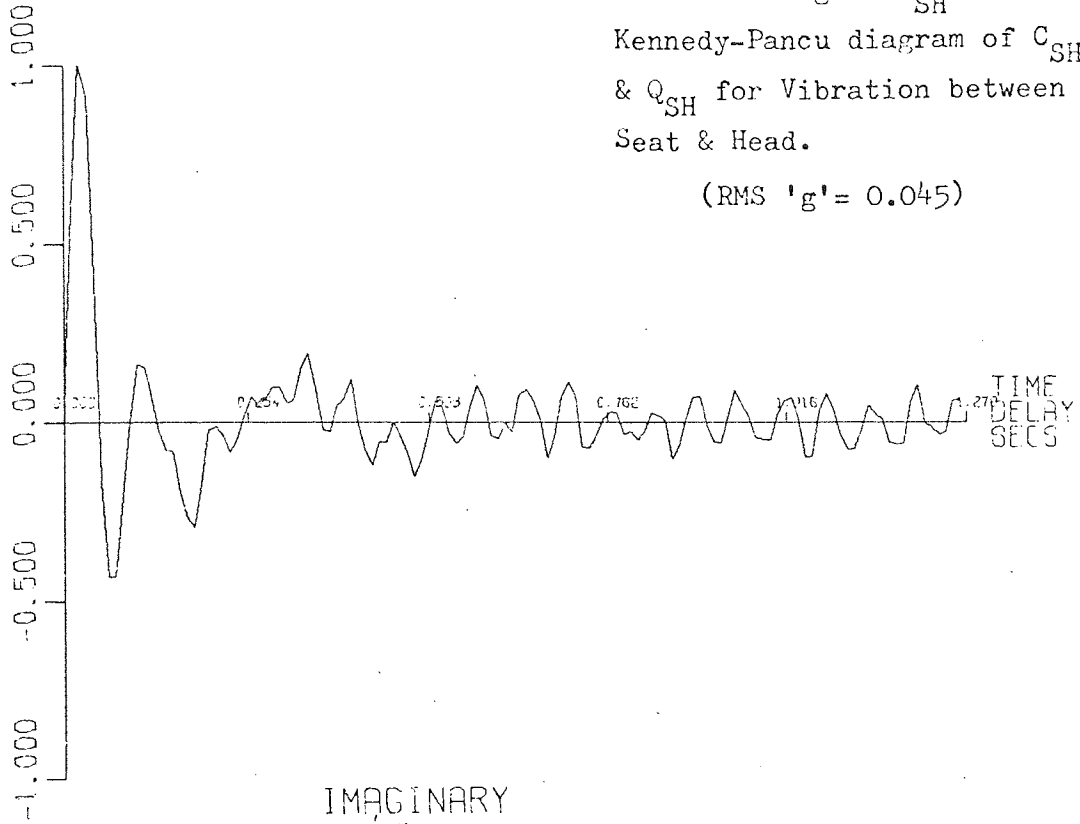

IMAGINARY

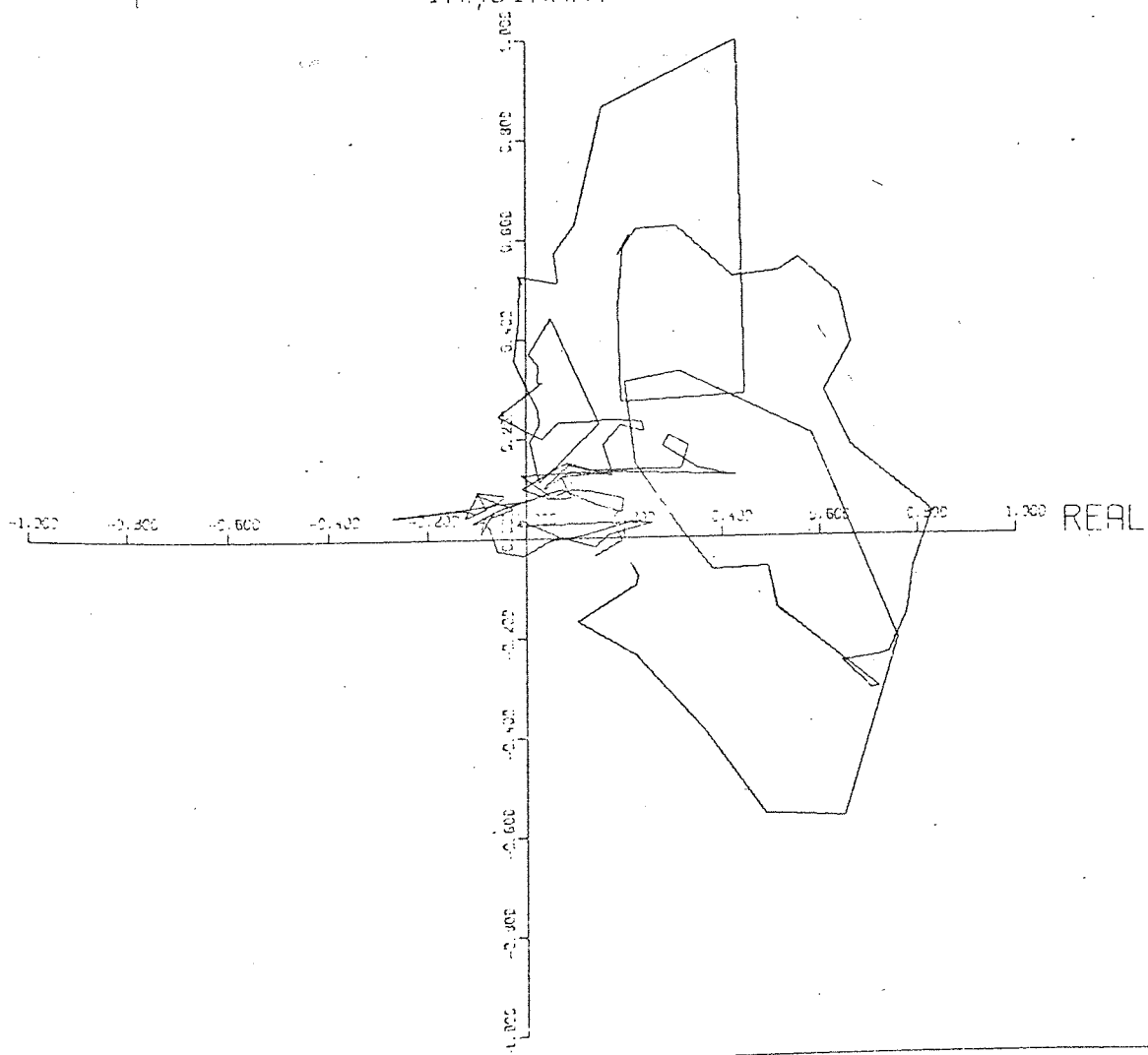

# FOURIER/HANNING CROSS SPECTRAL DENSITY ANALYSIS

G.D. WHITEHEAD

Figure 2.93

Gain & Phase Spectra based  
on ratio  $G_{HH}/G_{SS}$  for  
Vibration between Seat &  
Head.

(RMS 'g' = 0.045)

GAIN-DECIBELS

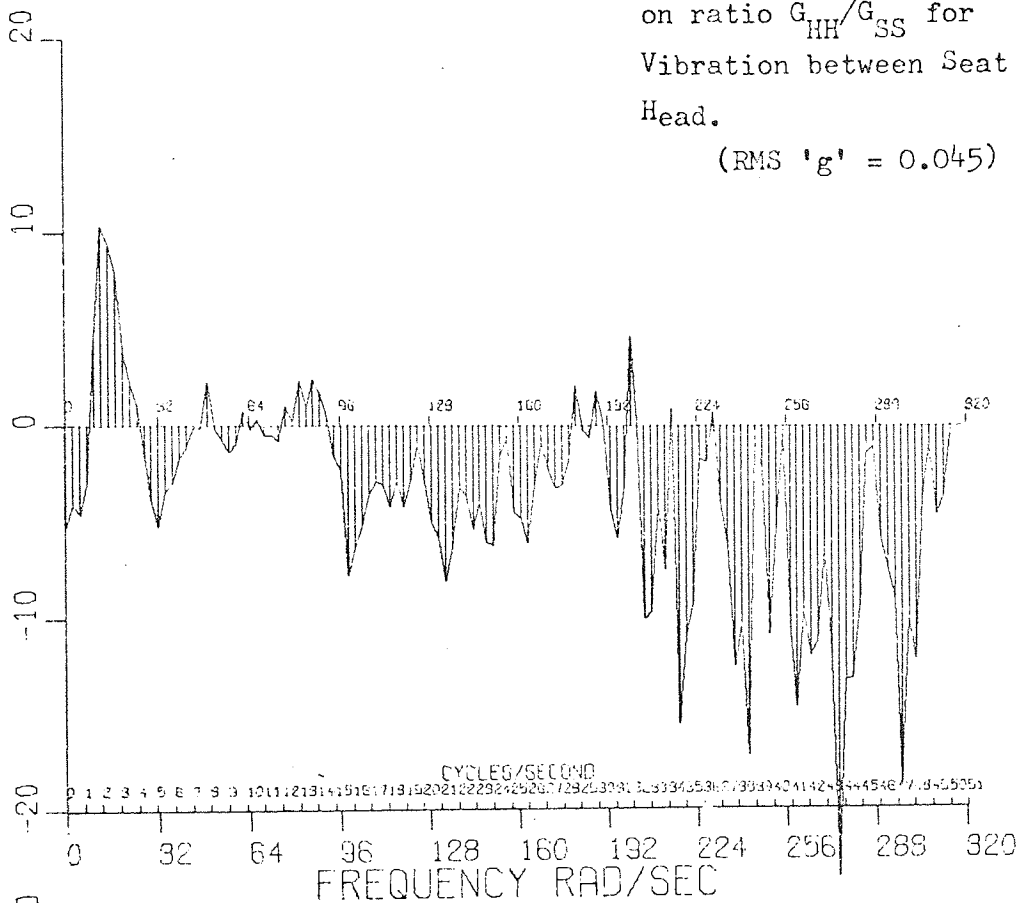

PHASE ANGLE -DEGREES

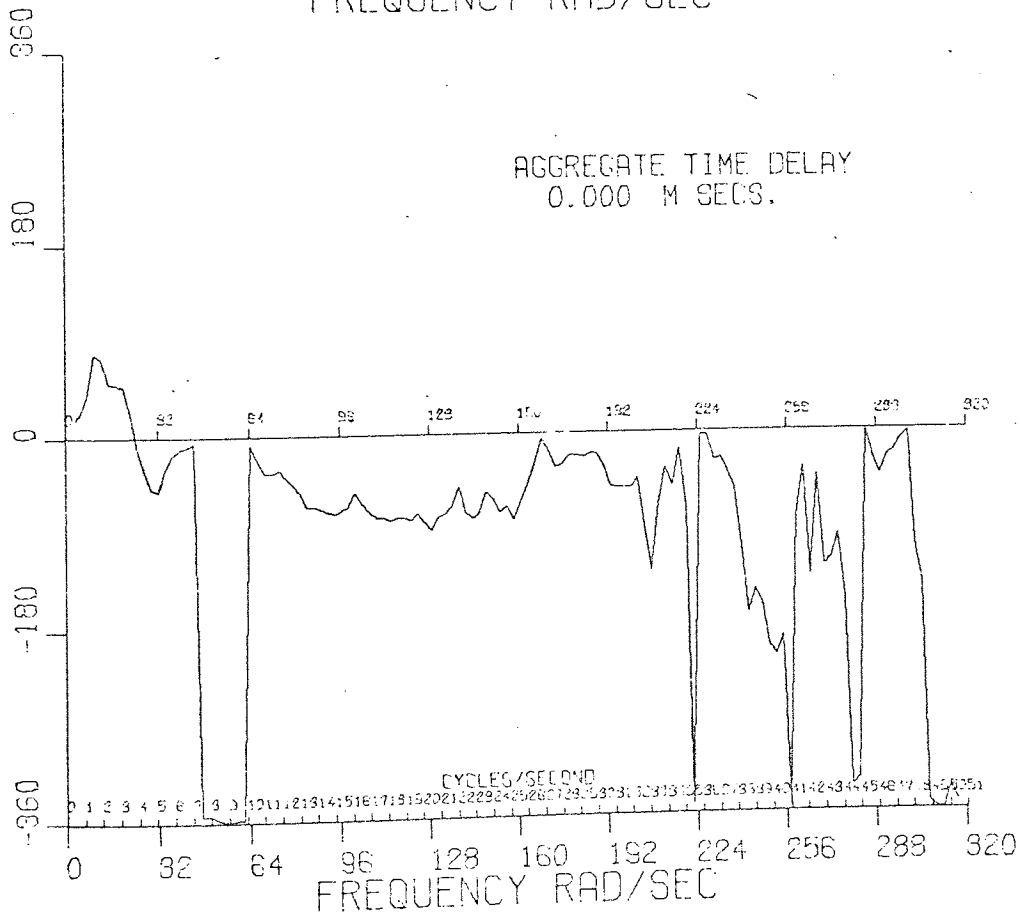

# FOURIER/HANNING CROSS SPECTRAL DENSITY ANALYSIS

G.D. WHITEHEAD

Figure 2.94

Gain & Phase Spectra based  
on ratio  $G_{SH}/G_{SS}$  for Vibration  
between Seat & Head  
(RMS 'g' = 0.045)

GAIN-DECIBELS

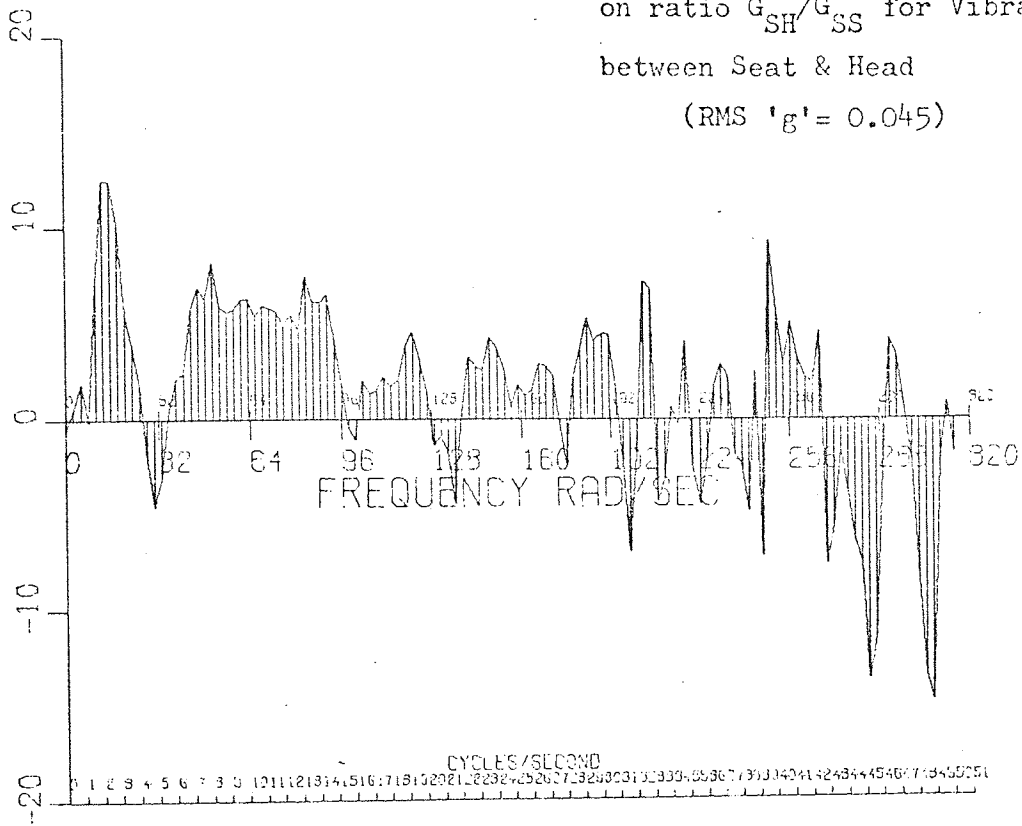

PHASE ANGLE -DEGREES

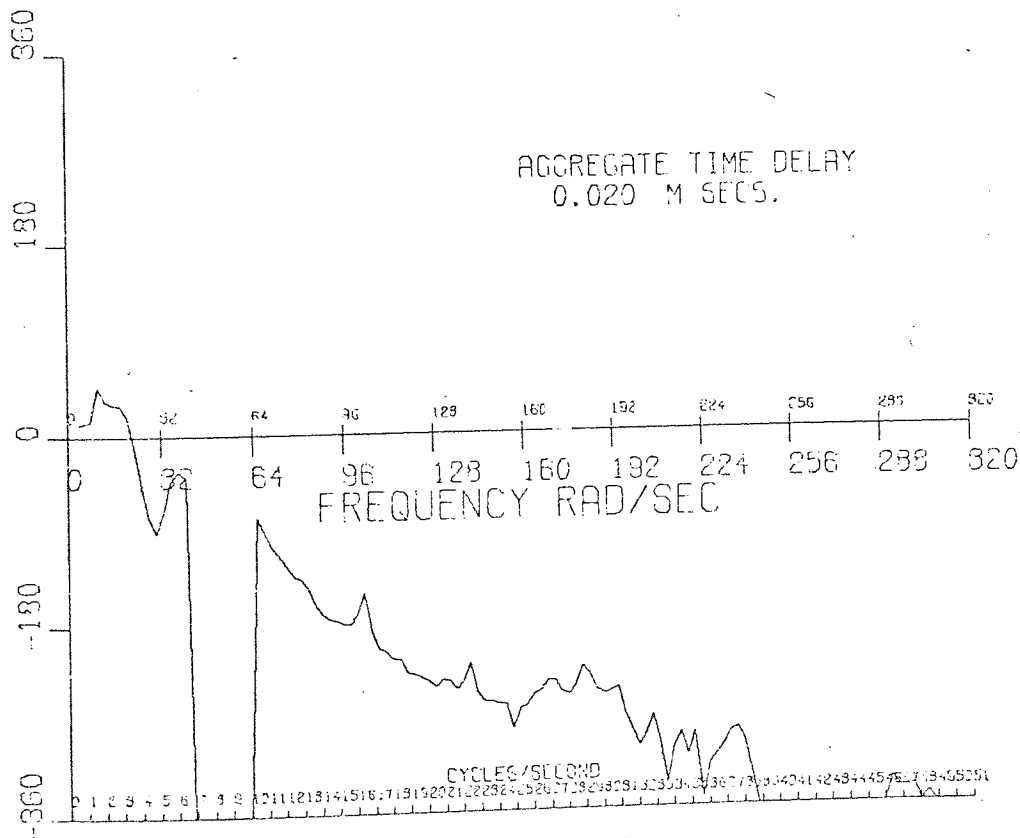

Correlation Function  $R_{SH}$  and Kennedy Panco diagram, the Spectral ratios  $G_{HH}/G_{SS}$  and the Spectral ratio  $G_{SH}/G_{SS}$ .

Input vibration.

The four subject/seat spectra  $G_{SS}$  were shown in Fig.2.37. The autocorrelation  $R_{SS}$  associated with the input spectra at each intensity (0.045-0.09 Rms'g') indicate Rms'g' values ie.  $Rms'g' \propto (R[0] - R[INF])$  whose proportions were in excellent agreement with the Bruel and Kjaer random noise meter settings which were used to control vibration intensity.

Head vibration and transmissibility.

Compared to seat vibration the Rms'g' intensity at the head was in general about 17% less. At 0.045 Rms'g' it was 86% of the seat value and 83%, 81% and 81% respectively at 0.06, 0.075 and 0.09 Rms'g'. In Figs. 2.89 and 2.90 this factor is indicated by the relative values of autocorrelation at zero time delay ie.  $(R[0] - R[INF])$ . Peak PSD at the seat at 0.06 Rms'g' and above (see Fig.2.37) occurred at 16.5Hz. The peak at this frequency was due to structural resonance in the seat mounting. Below 0.06 Rms'g' peak seat PSD was in the region 5Hz. Peak PSD at the head was always at least twice the value of that at the seat. For example the peak value in Fig.2.89 is  $2.216 \times 10^{-4} g^2/c/s..$  in Fig. 2.90 it is  $4.45 \times 10^{-4} g^2/c/s..$  and it was consistent between subjects and at all intensity levels in occurring at 3.5Hz. and a secondary peak always occurred at about 10Hz. The exact frequencies at which resonance and anti resonance occur in the human body between seat and head when subject to random vibration are given by the Quad component of the Cross Spectrum  $G_{SH}$ . Resonance is the zero power



crossover frequency between negative and positive power. Anti resonance is the zero power crossover frequency between positive and negative power. Fig.2.91 indicates that there are two and only two resonant frequencies with one anti resonance (which is necessary) between them. The first resonance occurs at 3.5Hz. and the second at 10Hz. Anti resonance occurs at 5.2Hz. In Fig.2.92, the lower of the two figures is the so called Kennedy Pancu diagram, The abscissa is the co-spectrum or Real part of the Cross Spectrum and the ordinate the Quadrature or Imaginary part. If the trajectory of the trace is followed it is noticeable that it begins with a series of three anticlockwise loops which end in a random path towards the origin. The loops denote resonance but only loops which crossover the zero line of the imaginary part denote resonance in the system between waveforms. Exact resonance is again the frequency at which the loop crosses zero from the -ve to +ve region of the imaginary axis. Only the first two loops in the trajectory have this property, they are thus resonant frequencies in the body. They can be interpolated very accurately as 3.32Hz. and 9.61Hz. Loops away from the zero ordinate value provide evidence of a resonant condition in the input waveform that is independent of the system between the waveforms, so that the third loop centred around Real = 0.3, Imaginary = 0.4 is the structural resonance in the seat mounting bracket.

The spectral ratios in Figs.2.93 and 2.94 show what are referred to as the Gain and Phase spectrum of the Cross PSD. Fig.2.94 is the ratio  $G_{SH}/G_{SS}$  This is the more accurate expression of vibration transmissibility because it takes into account the time delays which occur between input and output waveforms the value of which at each frequency are shown in the phase spectrum. Unfortunately, due to a slight programming oversight on the part of the author, the logic used to plot out the phase spectrum ran the plot

-377-  
 Transmissibility of the Body between Seat & Head  
 during Stationary Random Vibration - ratio is  
 based on  $G_{HH}/G_{SS}$ . (Gains shown are average of 4 S's)

Figure 2.95

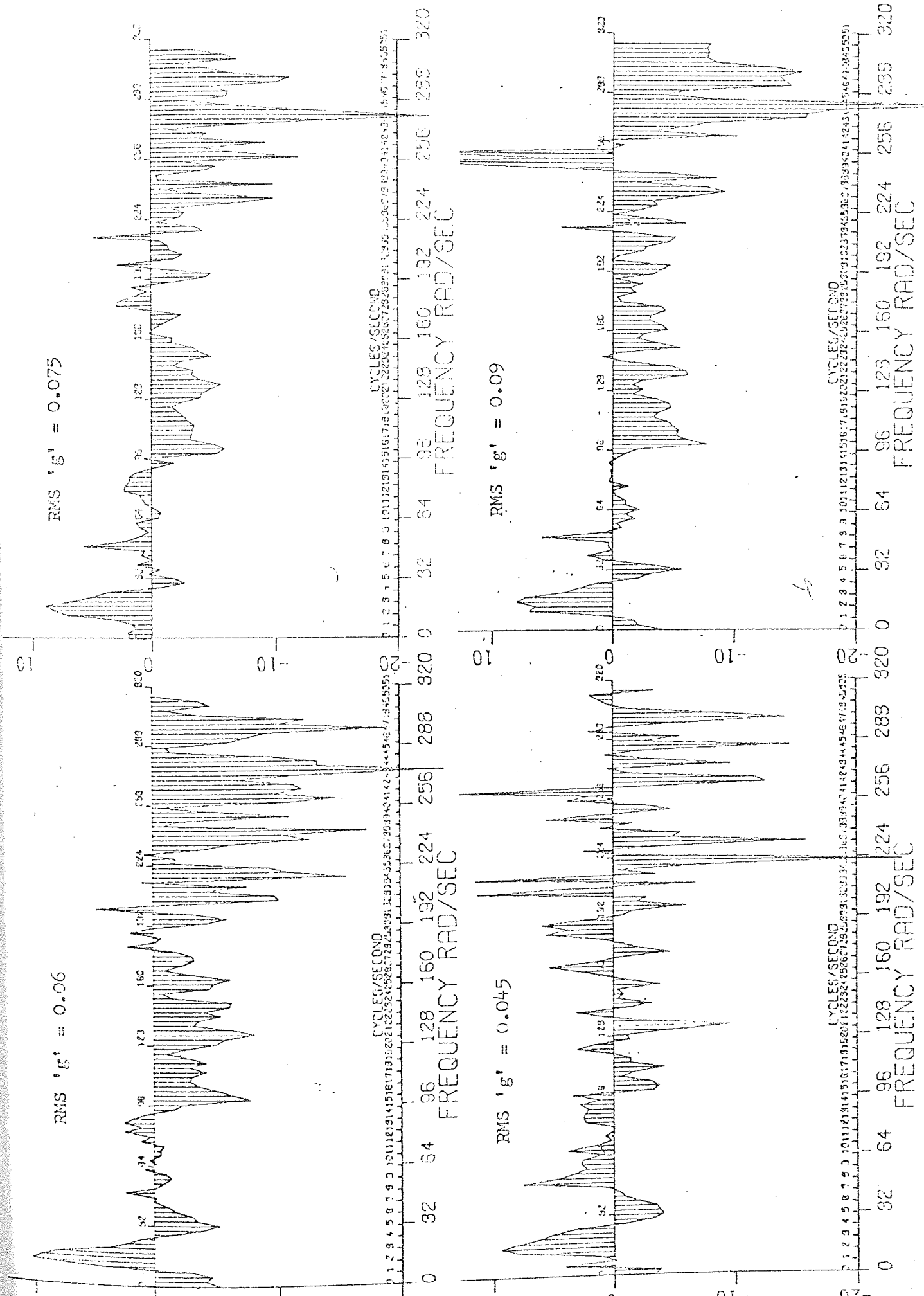

Transmissibility between Seat & Head at 4 levels of Stationary Vibration - ratio is based on  $G_{SH}/G_{SS}$ .  
 ( Gains shown are the average of 4 S's )

Figure 2.96

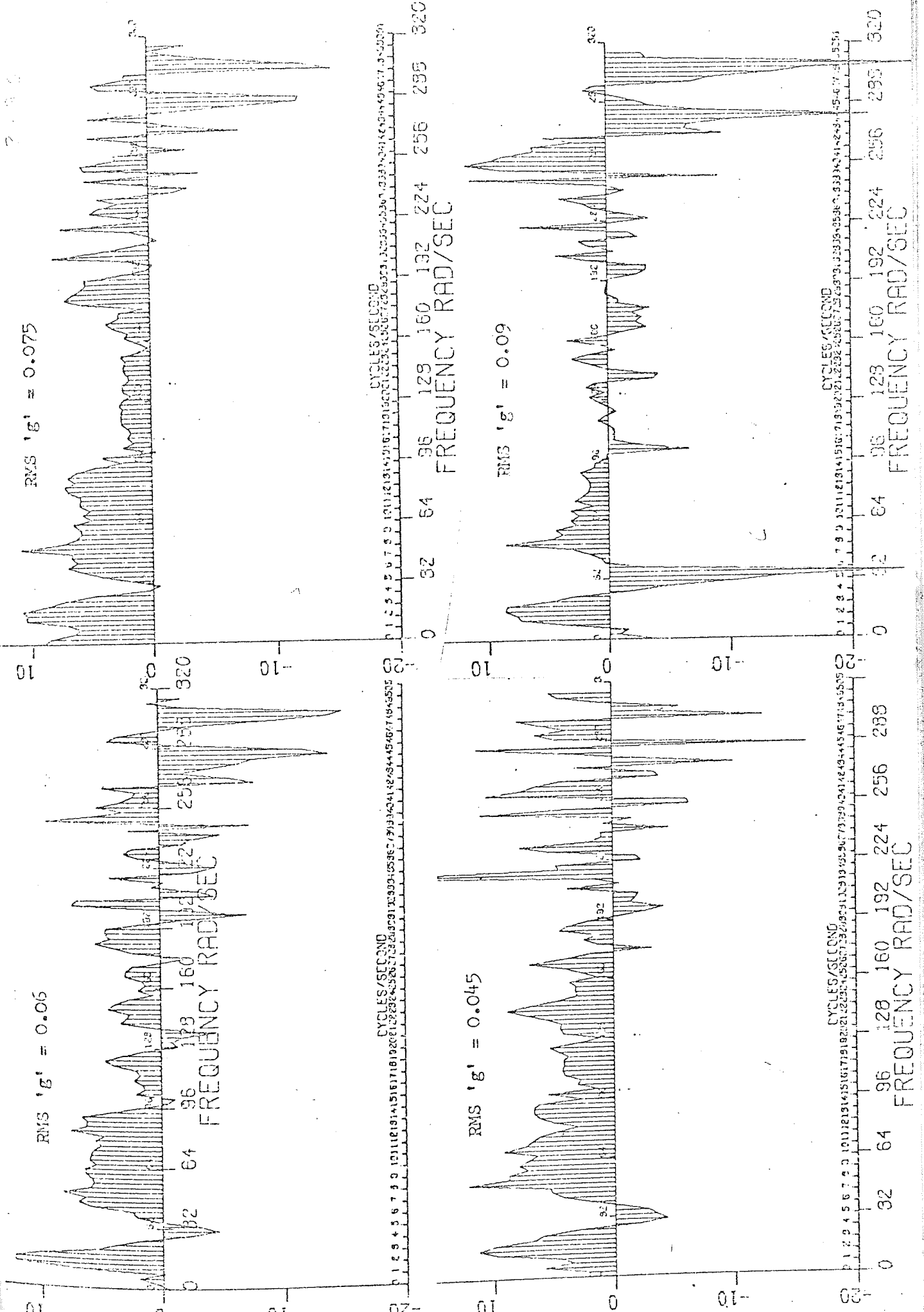

to  $-360^\circ$  in error when certain conditions were met so that the sharp drop to  $-360^\circ$  at 6.5Hz. should be ignored otherwise the phase spectrum is correct. The plotting error did not effect computation of the Gain Spectrum. The gain spectrum band upon the ratio  $G_{HH}/G_{SS}$ , Fig.2.93 contains no correction for the time taken for accelerations at the seat to appear at the head. Consequently it is a less accurate statement of the vibration transmission process but it is the one most frequently used. Fig.2.36 is an analog spectrum analysis of the same vibration. The gain spectrum shown was  $G_{HH}/G_{SS}$ ; the analog result agrees well with the digital result in Fig. 2.93.

Interpretation of the Gain Spectrum is straight forward. Positive gains indicate amplification by the body of the vibration input at the seat, negative gain, attenuation. Peak gain in Fig.2.94 occurs at a frequency near to the first resonance (3.32Hz.). The gain indicated is 12.5db. ie. the head vibration power density at 2.1Hz. is 4.2 times the power density at the seat. At 5Hz. it is -4.5db. ie. 0.6 times the seat vibration rising to an amplification of 6db. ie. times two between 7 and 14Hz.

Average gain spectra for the four subjects at 0.045-0.09Rms'g' are shown in Fig.2.95 and 2.96. for  $G_{HH}/G_{SS}$  and  $G_{SH}/G_{SS}$  respectively. Gains shown above 25Hz. in these figures can be ignored because the displacements involved are below the level where they would be troublesome to manual control. The gains in Fig.2.95 do not show a marked intensity effect; the gains in Fig.2.96 do but only at the anti resonant frequency around 5Hz. At this frequency at 0.09Rms'g' it is shown that subjects have reduced in some way the vibration that was input at the seat to one sixteenth (-24db.) of its value at the head. The implication is that some form of active

FOURIER/HANNING CROSS  
SPECTRAL DENSITY ANALYSIS

G. D. WHITEHEAD

Figure 2.97

Cross Spectrum  $C_{S,CB}$  &  $Q_{S,CB}$   
between Seat and Vibration  
at Control Box.

(RMS 'g' = 0.06)

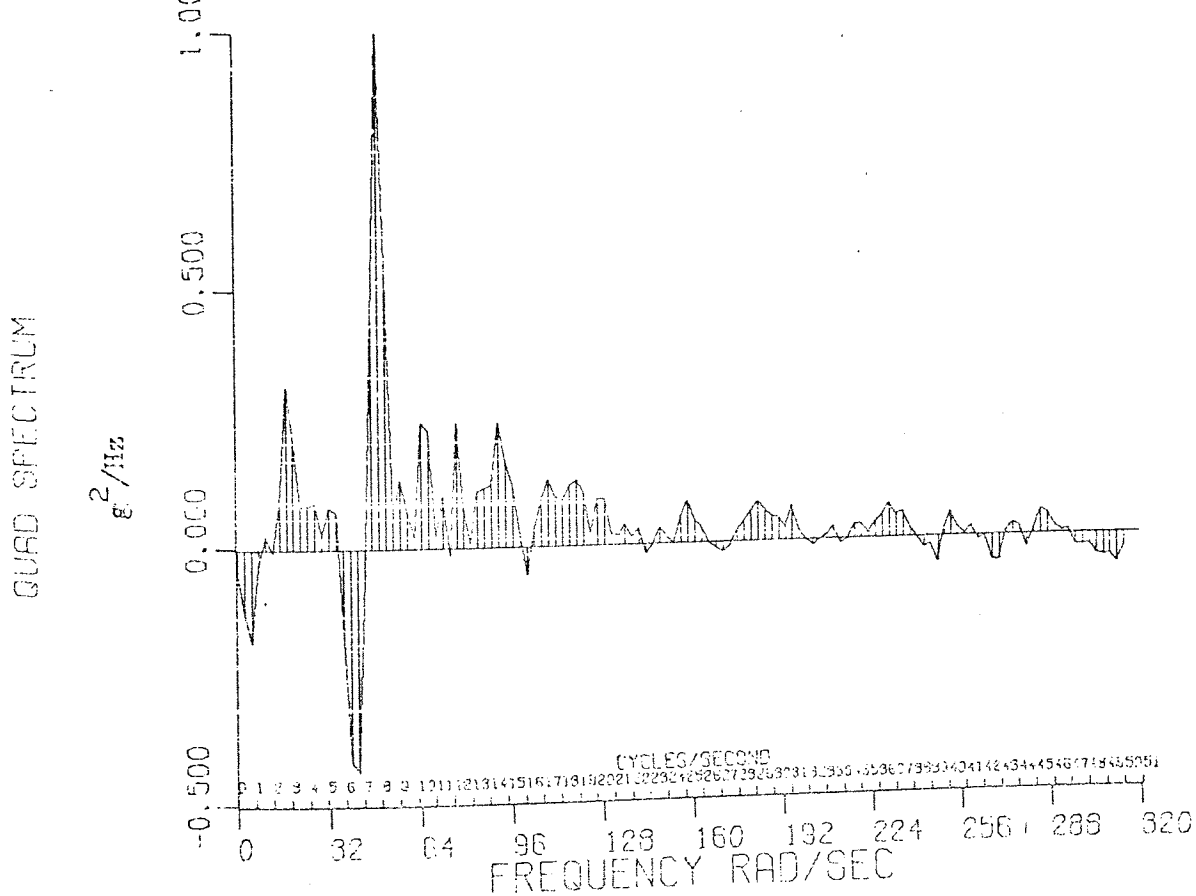
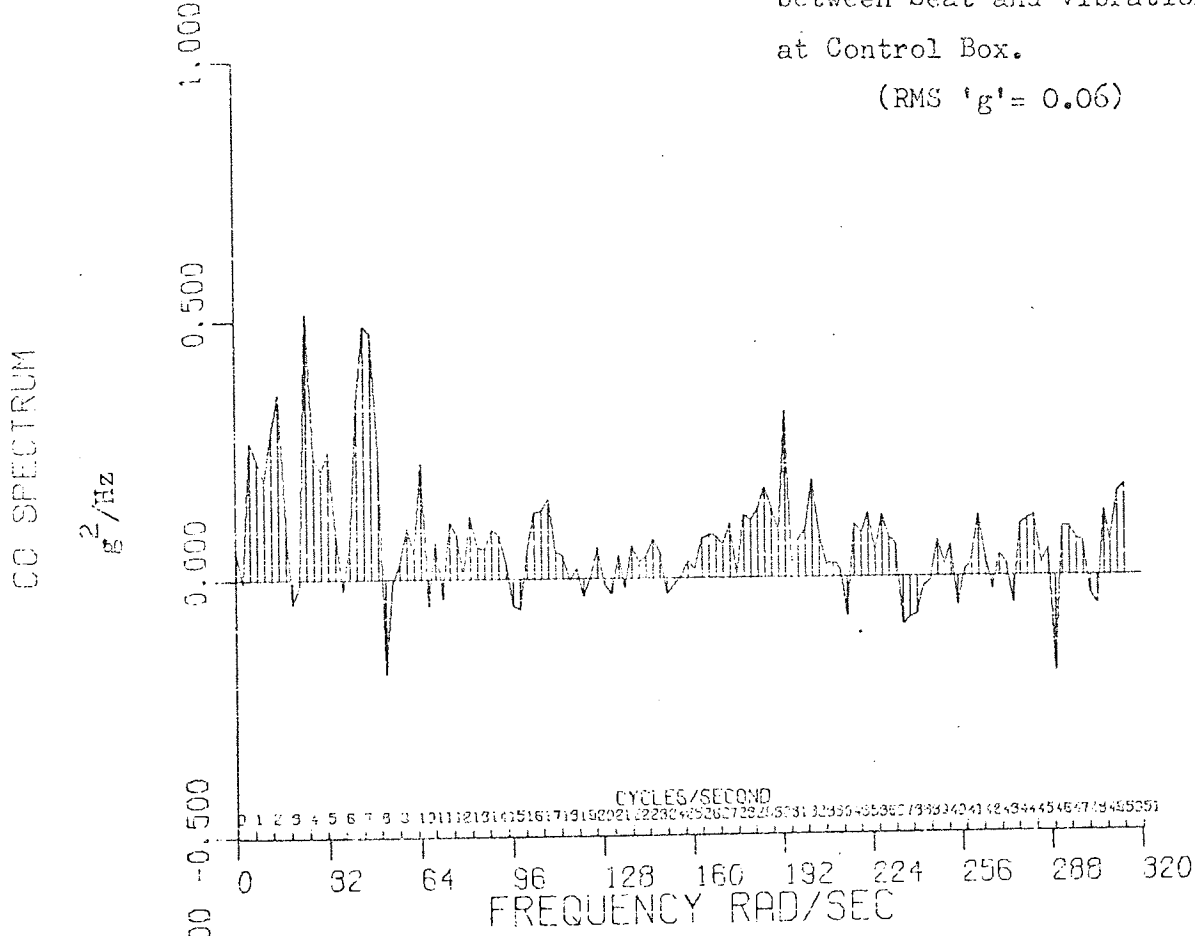

FOURIER/HANNING CROSS  
SPECTRAL DENSITY ANALYSIS

G. D. WHITEHEAD

Figure 2.08

Gain & Phase Spectra between  
Seat & Control Box.

(RMS 'g'=0.06)

GAIN-DECIBELS

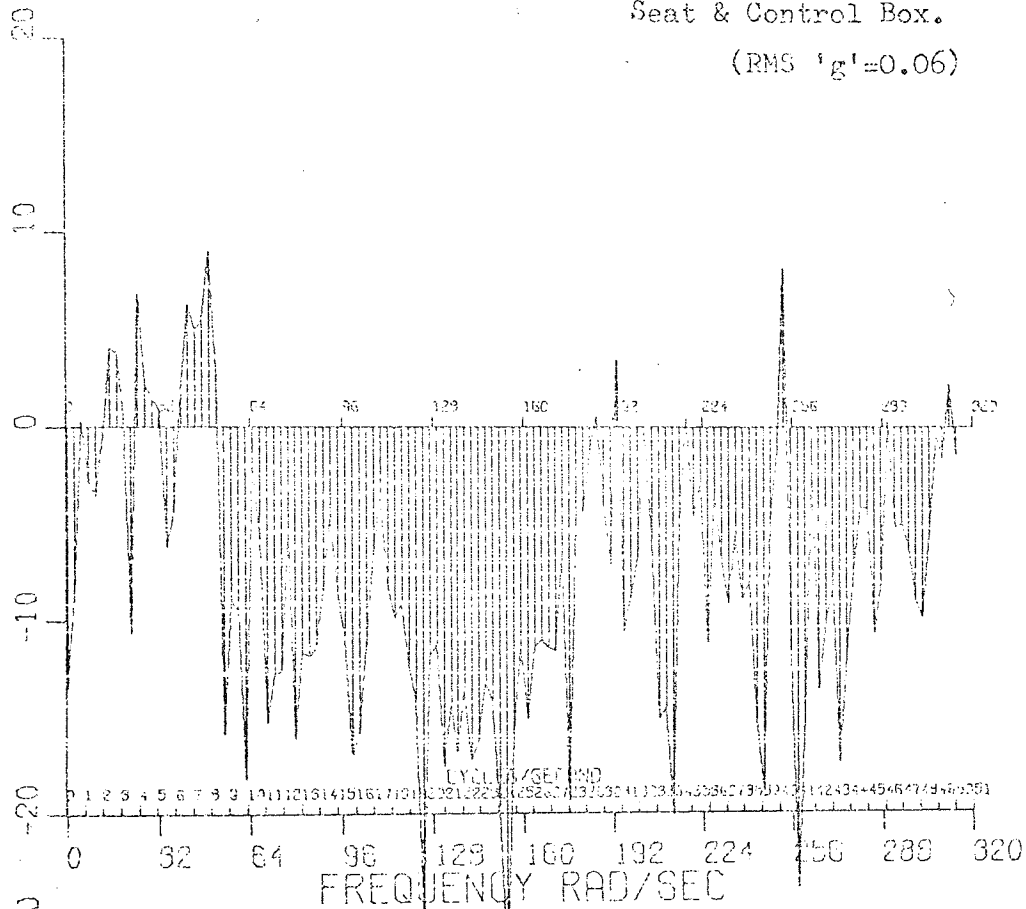

PHASE ANGLE - DEGREES

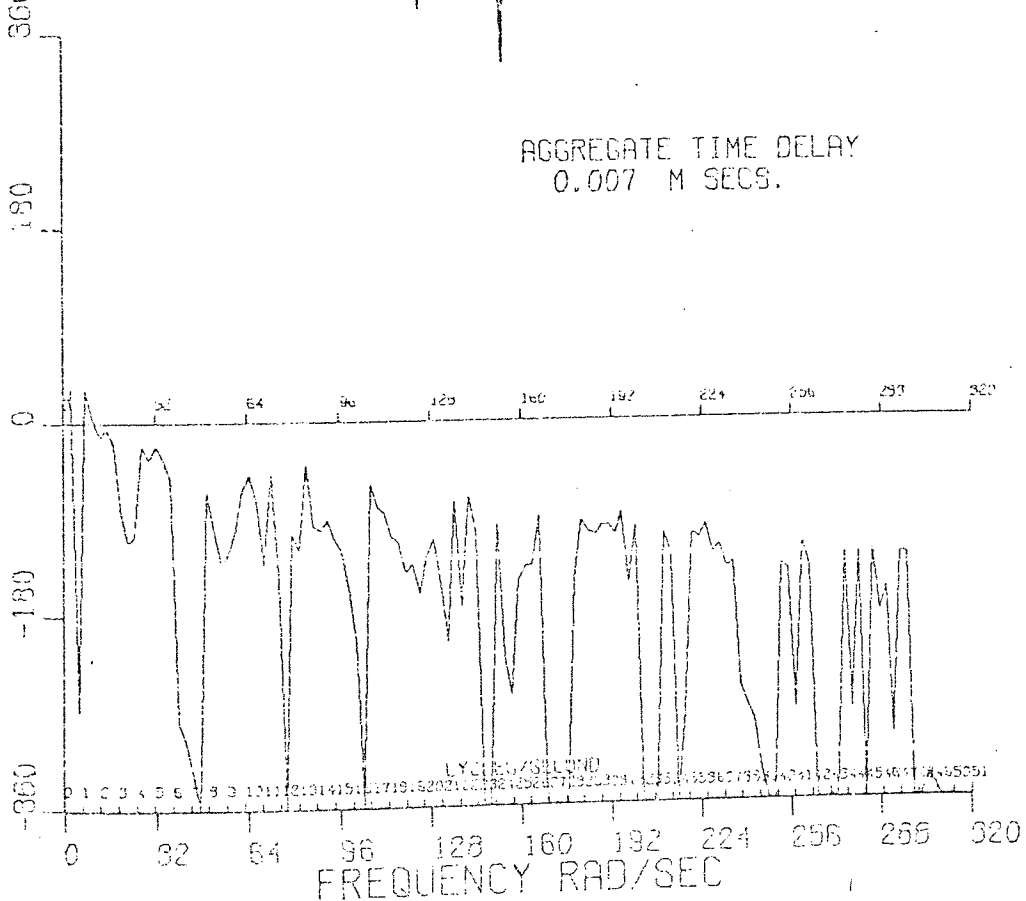

AGGREGATE TIME DELAY  
0.007 M SECS.

and selective vibration isolation mechanism has been brought into effect. But to actively track the seat with the head at 5Hz. would be impossible. After all the human operator can barely track with his hand at 2Hz! Some postural adjustment was observed and subjects did say when questioned that it was their strategy to lean forward and to arch the back in an attempt to minimise head and shoulder movement but it hardly seems credible that this would achieve an attenuation of -24db. only at 5Hz.. Part of the attenuation at 5Hz. is due to isolation provided by the seat spring.

Transmissibility from seat to head of subjects restrained by lap and shoulder harness was shown, in Fig.2.18 to average around 6db. at about 3.5Hz. In this study where the subjects were unrestrained the average gain between 0.045 and 0.09Rms 'g' based upon  $G_{HH}/G_{SS}$  was 9db. (based upon  $G_{SH}/G_{SS}$  it was 11db.). Thus it would appear that restraint amounts to no more than 3db. attenuation ( a factor of 1.4) between seat and head.

The Cross and Gain spectrums for vibration between seat and control box at 0.06Rms 'g' are shown in Fig. 2.97 and 2.98. The relationships are between vertical vibration at the seat and lateral vibration at the control. The vibration records were made during performance of the control task so that a large proportion of the control vibration was due to control movement. At 7Hz. in the Quad spectrum there is a well defined resonance which manifests itself as a 6-8db. amplification of seat movement in the Gain spectrum. 7Hz., presumably, must have been the lateral natural frequency of the control box on the lap when restrained by the hand/arm system. Another resonance in the Quad spectrum is indicated at about 1.5Hz. but it is thought that this is a spurious correlation between seat movement and control box movement resulting from control actions. The Gain spectrum

Fig.2.98 shows that at frequencies above 8Hz. one third of vibration power at the seat was correlated with vibration power at the control box. Below 8Hz. amplifications are indicated but it is not possible to say to what extent vibration transmitted at any of these frequencies caused loss of manual dexterity.

The vibration analysis was carried out on the stationary vibration records but there is no reason to suspect that the characteristics of non-stationary vibration at the seat or head at the same Rms'g' levels would be different. The transmission characteristics of the body should also be the same. Consequently the results of the above analysis may be taken as a description of the non-stationary vibration at the appropriate levels.

#### 2.6.12.4. Visual Inspection of Records.

All variables recorded during trials were made into pen recordings on fan folded paper for the purpose of visual inspection. An example for the three subjects who performed under conditions A, B and C are shown in Fig.2.113. The samples which are 48secs. in length show clearly the different control techniques adopted by the subjects, the relationships between display and control movement, the response of the adaptive variable to change in the error signal and to some extent the true relationships between the variables and the effect of the input on error and control actions. Looking along the length of the records it was apparent from the stationarity of the error record that the adaptive logic had done its job in keeping mean error modulus constant. Also apparent were the changes in control effort caused by vibration and the changes in control technique that often went with the increased effort. The meaning of the patterns both within and between



waveforms were obvious so that interpretation of the patterns was never difficult. Several insights were provided by visual inspection that were not revealed by computer analysis. For example it is apparent in the sample for subject T.H., Fig.2.113 that his control actions were assymmetric. The terminus of movement to the right (bottom of the trace) was more consistent than that to the left (top of trace). Momentary pauses in control action occur predominantly on the right hand side of the movement but the envelope of peaks on the left hand side of the movement suggest that the key feature of control involved 'pulling' the line away from the left hand side of the display and then allowing it to return to be switched back again. Lateral hand/arm movements for a right handed person appear to be more precise when the movement is to the right than when it is to the left. To prove this to yourself draw a straight line on a piece of paper, down the page about 3 inches in length, and then with a pencil start at the end of the line, on the line, and draw a series of short lateral lines down the line at about  $\frac{1}{8}$  inch intervals so that you end up with something which looks like a hair comb. Do it as fast as possible and then repeat the exercise by drawing a new straight line and putting the marks, this time, to its left, then compare your dexterity between left and right hand movements and your preference for direction. If you are right handed you should find that you prefer to draw a right hand comb and that your dexterity in so doing is greater than that for the left hand comb. In Fig.2.46 the effect of this strategy on the distribution of control movement is very apparent and the technique it is seen seems to intensify with time into the trial.

2.6.13. Experiment 1. - Summary of Results and Conclusions.

An experiment has been carried out to determine what effects stationary and non-stationary vibration in the range 0-0.09Rms'g' have on the difficulty of a manual control task. The experiment involved seven subjects, four experimental conditions, two repetitions per condition and a trial length of thirty minutes.

The control problem was a first order instability. Degree of instability was the adaptive variable and also the index of task difficulty. Before the effects of vibration were scored subjects were given practice sessions sufficient to bring their performance up to a plateau of ability. They were not told how to control or that the task was adaptive. In addition to visual inspection, detailed analysis of four trial records was carried out and a novel form of analysis compared to a more conventional technique.

At 0.09Rms'g' the average effect on the task was an increase of 33% in the index of difficulty when compensatory tracking was the control criterion and a 31% increase when the criterion asked that the state of the controlled element be kept within the margins of the display or both. The effect for the best subject using the compensatory criterion at 0.09Rms'g' was a 29% increase in difficulty. For the worst subject at 0.06Rms'g' using the same control criterion the difficulty rose 54%. There was no difference in the effect between stationary and non-stationary vibration and no difference between skilled and unskilled controllers in the level of difficulty attainable without vibration but with vibration those subjects experienced in coping with vibration found the task least difficult (as indicated by the index of difficulty).

vibration analysis revealed that 81% of 0.09Rms'g' vibration power at the seat was transmitted to the head. At 0.045Rms'g' 86% was transmitted. Spectrum analysis revealed that this power at the head was concentrated in a narrow resonant band centred on 3.32Hz. and a wider resonant band around 9.61Hz. At these resonant frequencies the average gain through the body during control was 9-11db. and 1-6db respectively dependent upon the spectral ratio. At 0.09Rms'g' the average peak power density at the head was  $4.45 \times 10^{-4} \text{ g}^2/\text{c/s.}$  at 3.32Hz. compared to the highest value at the seat which was  $2.15 \times 10^{-4} \text{ g}^2/\text{c/s.}$  at 16.5Hz.. Some changes in the transmission process with Rms'g' intensity were noted. There was a tendency towards lower amplification in the region of resonant frequencies but the most spectacular effect was an unexplained increase in attenuation of vibration centred on 5Hz. at the 0.09Rms'g' level. Between the control box and vibration input at the seat there was a well defined vertical/lateral resonance at 7Hz. an effect which may have caused some interference with manual dexterity.

Analysis of the task variables provided explanations for the effect of vibration on the task difficulty and descriptions of control behaviour. When performing with the compensatory tracking criterion in mind, spectrum and time delay analysis revealed that changes in task difficulty during vibration were the result of increments in the effective time delay caused by a reduction in the human operator gain characteristic. This explanation is based upon evidence obtained from one subject during one trial. For this subject the course of events was as follows : Before vibration a high level of task difficulty was attained so that when vibration began the controlled element was in a highly unstable state. This state was achieved by a combination of speed and accuracy in compensatory tracking. Immediate with the appearance of vibration, accuracy fell and so did task difficulty - the

controlled element gain. As vibration intensified control accuracy continued to fall and with it controlled element gain. To compensate for the latter the subject increased her gain with longer amplitude control movements in an attempt to counteract the effects of vibration but there came an intensity when seemingly she could neither raise her gain or maintain sufficient accuracy with the result that she abandoned her effort allowing her gain to fall to a low value. With this the adaptive logic lowered task difficulty until the vibration began to subside when the subject renewed her effort - increased her gain and accuracy and did so to such an extent that when vibration ceased she was forced to equalise a very high controlled element gain by generating an attenuated response to the display movement.

The 'scope width' criterion and to some extent the combined criterion resulted in the development of a continuous bang-bang control technique. This control behaviour conforms to the maximum effort principle found in Servo Control Theory. Its use minimises the time taken to move the control and therefore the displayed variable from A to B. It introduces a predictable component into the display movement; an artificial error signal into the adaptive logic and if the amplitude of movement is large enough the movement can be used to mask part of the input signal. Because of the unstable nature of the controlled element it is most likely that the technique was developed in order to benefit from its minimisation of movement time. But having developed the technique for this reason subjects probably extended its use to include input masking and control over task difficulty. The latter use implies that certain subjects were able to exercise control over the adaptive logic. One subject whose index of difficulty fell whilst using bang-bang control during vibration increased

his effort by raising his amplitude of movement which increased the error input to the adaptive logic which in turn resulted in a fall in task difficulty. On another occasion vibration had the opposite effect. It caused the subject to lower the speed and amplitude of his control movement. As a result part of the artificial error was removed but error related to the input signal increased due to increased response time and removal of the masking signal. The effect on task difficulty was the same. Both kinds of response to vibration reflect an inability to cope with the task and the resultant changes in the index of difficulty provide a valid measure of the effect of vibration on its difficulty.

Describing Function Analysis - Human operator describing function analysis in the region of input frequencies, revealed that subjects were not performing a simple gain or equalisation function. They were inducing movement into the display outside the range of input frequencies under all control criteria and bang-bang control was non-linear to an extent such that Gaussian display movement was accompanied by near sinusoidal control movement. For these reasons the Quasi Linear Describing Function was found to be inappropriate for this task but provided some insight into control behaviour in the region of operator induced frequencies. For the human operator the closed loop problem presented by this task was more naturally one of switching. That is to say of predicting the time at which the force applied to the control should be removed in order to achieve a desired control and display displacement. A problem which is made more difficult by the variable nature of the controlled element. An appropriate analysis therefore is one able to describe this switching behaviour in relation to movement of the Controlled Element, Controlled Element gain, Operator gain and Vibration.

Switching Skill - Refinements of the bang-bang technique to take account of differences in the ballistic accuracy of left/right compared to right/left hand/arm movements were noted in the most skilled subject. His switching technique appeared to be 'left justified'. That is to say his right hand movements were more a series of flicks to the right such that the terminus of movement to the right was near constant with the closed loop control focussed and cast into the terminus of movement to the left. A start on the study of bang-bang behaviour was made by Smith (1962) and Wilde and Westcott (1963). Both found that the force-velocity-displacement patterns for the minimal time movement of masses was close to the ideal of the maximum effort principal that is a square wave force pattern with force reversal in mid position, a velocity triangle across the displacement and a parabolic displacement time history between the start and finish of the movement.

Arousal - During vibration no easing of the task was noted but in most subjects there was an arousing effect due to the non-stationary vibration which resulted in increased effort as indicated by operator gain and control movement power. The effect was not correlated with any particular point in the non-stationary cycles.

Heart Rate - Subjective measures of difficulty were not obtained in this experiment but heart rate provided an index of psycho-physical arousal. Heart rate and change in rate were related to subject experience in coping with vibration. Within trials the average rate for the most experienced subject fell from 78 to 75 beats/min.. For the least skilled it fell from 105-91 beats/min.. Between trials the average rate for the most and least skilled subjects remained constant suggesting full psycho-physical

adaptation and lack of it respectively for the experienced and inexperienced subjects.

Waveform Analysis - Much of what was revealed by waveform analysis was visible in the chart recordings but quantities such as the power density of control movement enabled quantitative assessment of the behavioural qualities. Amplitude probability density analysis proved particularly useful when seeking to understand the nature of stimulus and response as did spectrum analysis although the elaborate Cross spectrum technique used to describe the S/R relationship proved to be inappropriate for the control task studied. Nevertheless together with time delay analysis it was able to provide sufficient information to explain the changes in task difficulty observed. Zero crossing analysis however, failed to show up the effects of vibration because changes in effort occurred along amplitude rather than the frequency dimension. Phase plane analysis which was tried out for the first time in this study resulted in evidence which was at times in conflict with PSD analysis. Like zero crossing, phase plane analysis detects frequency independent of amplitude but unlike zero crossings it detects frequency at all values of amplitude. Thus it was able to detect changes in control behaviour related to amplitude of control movement but the result was not always in agreement with PSD analysis. It is a method of analysis which has the efficacy to separate and to show interactions between amplitude and frequency. Thus whenever there is reason to suspect that changes are taking place independently along these dimensions or if ever there is reason to suspect that there is interaction between them then phase plane analysis should prove useful. In this study the technique has been applied to the description of single waveforms only but combined with cross correlation analysis it could be extended to describe the frequency

relationship between waveforms. It is faster than Fast Fourier Transform but its speed depends upon digitalisation rate.

Conclusions - The average degree of instability, , associated with an adaptive version of the Jex et al. Critical Control Task, that subjects could control, when subject to random vertical vibration in the range 0-0.09Rms'g' is given by :

- $\lambda = 7.4 - 24.5 \text{Rms'g'}$  - rads/sec. When control criterion compensatory tracking
- $\lambda = 3.52 - 10.2 \text{Rms'g'}$  - rads/sec. When control criterion to keep state of controlled element within margins of display.
- $\lambda = 4.61 - 19.4 \text{Rms'g'}$  - rads/sec. When control criterion a combination of the two above.

The compensatory tracking result without vibration indicates an instability of 7.4rads/sec.. The average value obtained by Jex et al. in the Autopaced version of their task was 6.2rads/sec.. The difference it is believed was due to an allowance of 2.5rads/sec. which was given in the adaptive score to compensate for the standard of performance imposed upon subjects. This allowance was estimated during development trials. It appears that the estimate was on the high side which could account for the difference.

The adaptive rate of 0.3rads/sec/sec. chosen during development trials to prevent the task from betraying its closed loop feedback control feature was completely successful because after 12-30 minute trials no subject was cognizant that the task was adaptive. Nevertheless during control with the second criterion, skills were developed with which subjects were able to control the adaptive logic to their own ends but in spite



of this the results obtained were faithful reflections of change in task difficulty.

Implementation and development of the adaptive task occupied roughly one half of the total time taken to set up and conduct the first experiment. Once developed it proved to be an efficient way to experiment. It avoided problems associated with individual difference and provided an on-line record of performance. In so doing it helped to remove some burdensome duties from the experimenter leaving him free to monitor and manage the experiment. Confident in the knowledge that the conduct and results of the trials were largely independent of the human experimenter, the experimenter was able, at times, to leave the experiment in the charge of an assistant.

2.7.0. Experiment II On the Relationship between Acceleration and Frequency of Sinusoidal Vibration and the Manageable Difficulty of a Manual Control Task.

This second experiment was conducted with three aims in mind. The first aim was to provide an estimate of the effect of vertical sinusoidal vibration on the difficulty of the same adaptive control task. The second was to provide an estimate of the maximum acceleration levels that subjects could sustain at the maximum difficulty levels attainable at frequencies in the range 0-25Hz. Third, to compare random with sinusoidal vibration in terms of its effects upon the index of task difficulty,

The task used in this experiment was identical with that in the first experiment. The performance measure, adaptive logic, adaptive rate and performance standard were the same but on this occasion the adaptive variable ( $\lambda$ ) was used also to adjust the amplitude of the sinusoidal vibration according to the same adaptive logic. Adaptation of vibration amplitude was accomplished by multiplying the output of a sinewave generator by the adaptive variable to form the command signal for the vibrator.

2.7.1. Vibration

The vibration was a sinusoidal sweep from 0-25Hz. at a rate of 1Hz/minute. The duration of exposure was therefore 25 minutes which was preceded by a 5 minute period without vibration. The adaptive variable was scaled so that at 8rads/sec. (the value of difficulty expected without vibration) the amplitude of movement was 2 inches. The relationship between instability and amplitude was therefore 1rad/sec. = 0.25inches, giving a maximum

adaptive rate of 0.075 inches per sec., so that in less than half the time taken for the sweep to increment 1Hz. the amplitude was able to change from zero to its maximum of 2".

Acceleration was, as before, measured at the seat, head and control box and calibrated in the same way.

### 2.7.2. Subjects.

Four of the male subjects D.P., J.G., T.H. and C.H. who had participated in the first experiment were used for the sinusoidal study.

### 2.7.3. Procedure

The trials for experiment II were carried out on the day after subjects had completed trials for the first experiment. Before the recorded trials subjects were again given one practice trial to familiarise them with the nature of the sinusoidal vibration. The instructions given asked subjects to use compensatory tracking ie. to minimise deviation of the moving line from centre zero. They were told that they could terminate the trial at any time by moving the control lever hard over to the left or right. The effect of this was to introduce a large error into the adaptive logic with the result that the vibration was automatically cut off.

Three trials were performed by each subject but on this occasion no feedback was given since it was felt that there was sufficient inherent in the display and in the intensity of vibration.

Figure 2.99 The Effect of Vertical Adaptive Sinusoidal Vibration on the Difficulty of a Critical Control Task.

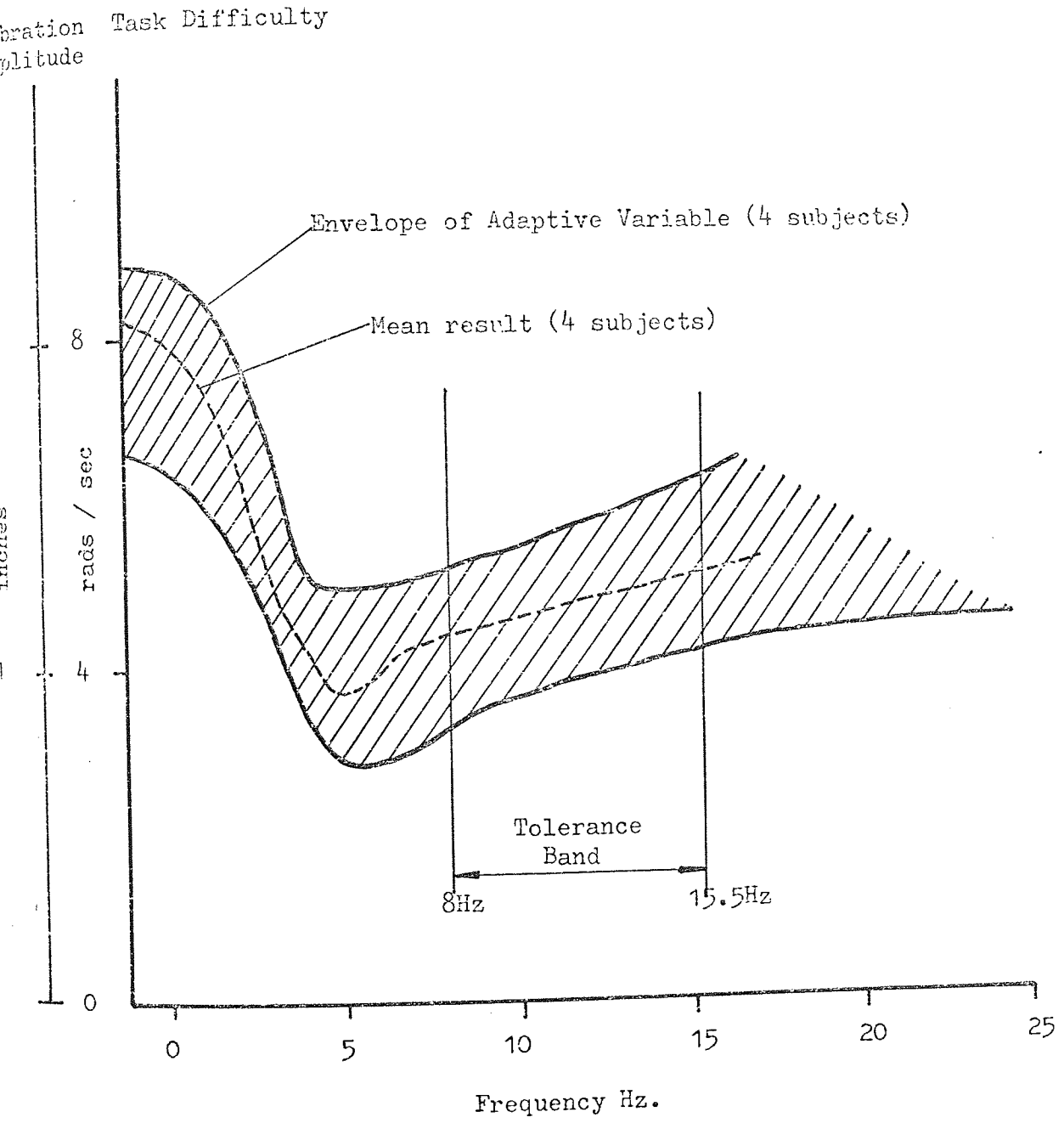

- (a) Peak acceleration levels measured at Seat during Adaptive Sinusoidal Vib.
- (b) Relationship between Task Difficulty, Peak acceleration and Frequency of Vib.

Figure 2.100

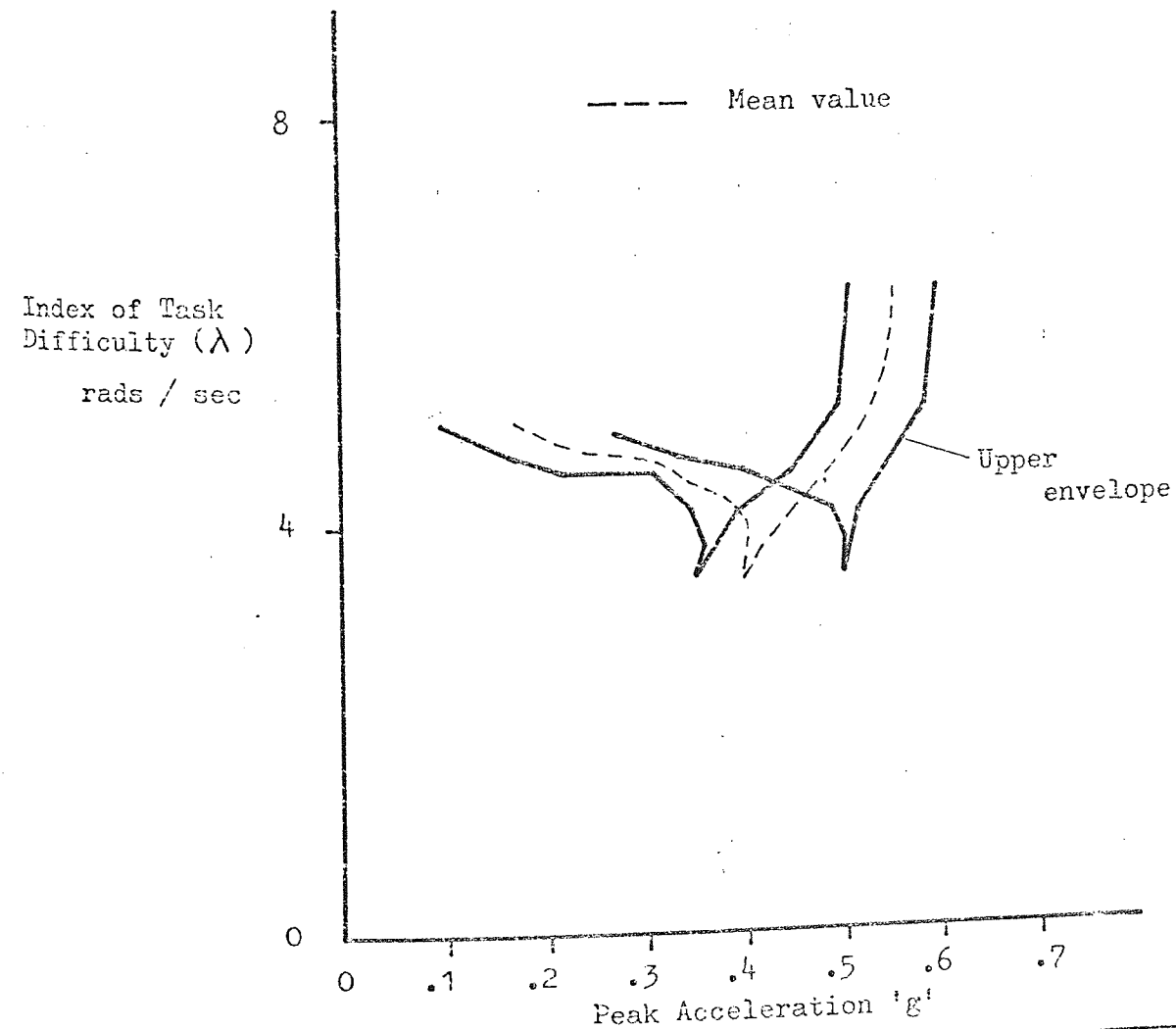
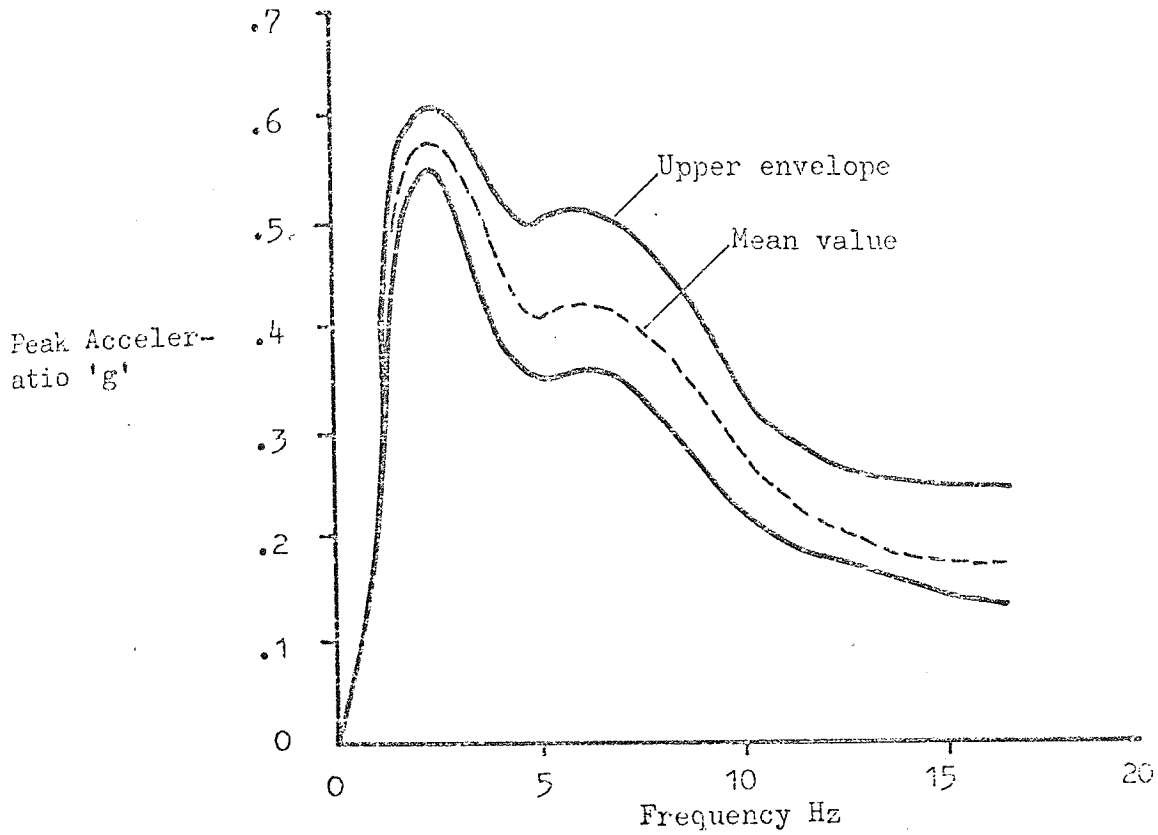

#### 2.7.4. Results.

The average index of task difficulty with the corresponding amplitude of vibration against frequency is shown in Fig.2.99. The band either side of the mean is total envelope of scores for all subjects. Not all subjects were willing to tolerate the sinusoidal vibration above 8Hz. even although they were well able to perform the task. Two subjects on one trial each were able to sustain the vibration up to the limit of 25c/s. but the other ten trials were all terminated between 8 and 15.5Hz., the majority around 12Hz.

The amplitude in Fig.2.99. refers to the motion of the hydraulic jack. At frequencies above 2Hz. these motions were attenuated by the seat. The resultant peak accelerations transmitted to the subjects as measured at the subject/seat interface are shown in Fig.2.100, together with the relationship between the index of difficulty and peak acceleration with frequency as parameter. Both Figs. 2.99 and 2.100 show clearly that vibration at 5Hz. had the most effect on task difficulty and that frequencies between 5 and 8Hz. had less effect and that above 8Hz. peak acceleration levels fell but the index of difficulty remained constant. The range of peak acceleration levels that subjects could sustain at the levels of difficulty produced at each frequency are shown in Fig.2.100. At  $\lambda = 3.6$  rad/sec. at 5Hz. subjects were able to cope with peak accelerations in the range  $\pm 0.35 - \pm 0.5$  'g'. The effect of this frequency/g combination on task difficulty was greater than 0.09Rms'g', the highest random vibration intensity used in Expt.I, so there can be no direct comparison but using the regression equation  $\lambda = 7.4 - 24.5 \text{Rms}'g'$  an extrapolated Rms'g' equivalent of 0.155 is indicated. A full set of such comparisons are shown in Fig.2.101.

(a) The Sinusoidal Equivalent of Random  
Vibration Intensity as Indicated by  
their effects on Task  
Difficulty.

Figure 2.101

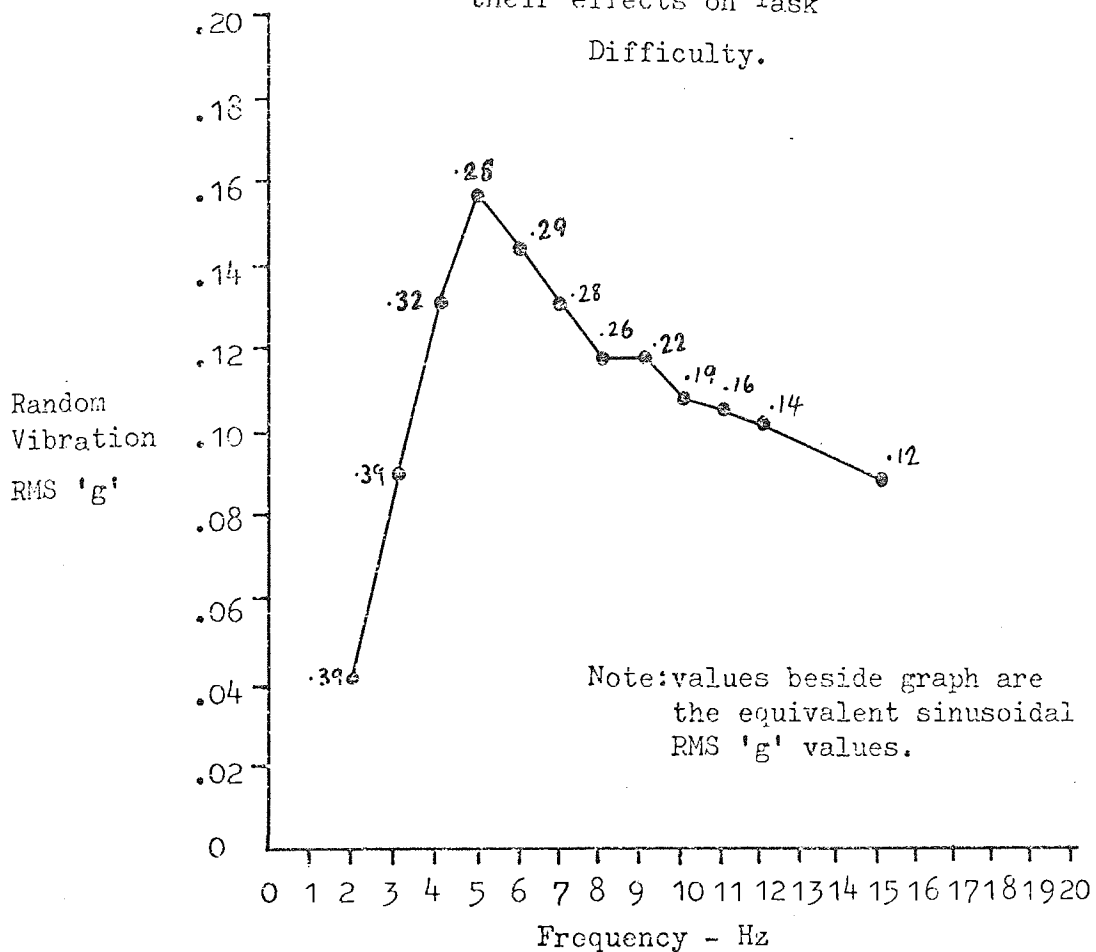

(b) The Ratio of Equivalent Random & Sinusoidal  
Vibration RMS 'g'.

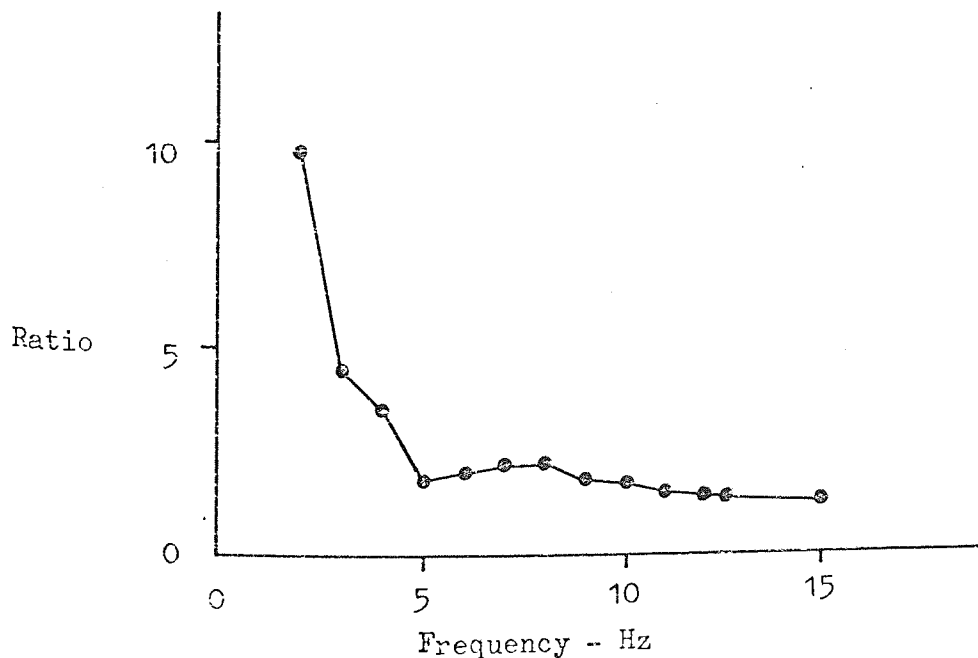

2.7.5. Conclusions.

This experiment has shown that at frequencies above 8Hz. the human operator runs out of tolerance well before he becomes incapable of performing a very difficult manual control task. The experiment has confirmed the frequent finding that human performance is most sensitive at or near 5Hz. That the particular task used in this experiment was made more than twice as difficult by 5Hz. vibration with peak acceleration between  $\pm 0.35$  and  $\pm 0.5$  'g' and that this was equivalent to 0.155Rms 'g' - an extrapolated value of random vibration whose amplitude and power spectrum characteristics were given in Experiment I.



2.8.0.

Experiment III

On the Development of Control Strategy During Adaptive  
Random Vibration.

Experiment III was conducted as a companion to the previous experiment in order to compare the effects of adaptive random vibration with the adaptive sinusoidal vibration previously used but only the results for one subject are presented here. Results for this one subject have been analysed in detail and the purpose of their presentation is to show how the subject progressed and dealt with the task from the beginning of practice to the end of the first trial. The task and its adaptive implementation were the same as Experiment II. Instead of sinusoidal vibration Stationary Random vibration was used whose characteristics were given in Experiment I and instead of amplitude modulation the adaptive variable was used to vary Rms 'g'.

The individual, whose control behaviour is the subject of this presentation was new to the experiment. He was a Test Pilot, 37 years of age and his control behaviour towards the task was typical of the more skilled subject. His brief for the experiment was the combined criterion used in Experiment I. That is to say he was told to minimise deviation of the moving line from centre zero and to keep the line on the scope. He was given one practice session without vibration for 30 minutes and then two hours later he proceeded to the first of three trials each of which featured adaptive random vibration which was switched on 12 minutes into the trial, and which remained on for 10 minutes, the trial ending in a three minute period without vibration. The subject was told in his brief that he would be vibrated for 10 minutes but was not told when it would begin. He was not told that the task and vibration were adaptive and was given no instructions

Phase Plane Plot for Epoch's 7-16, 1st Trial of Subject BH.

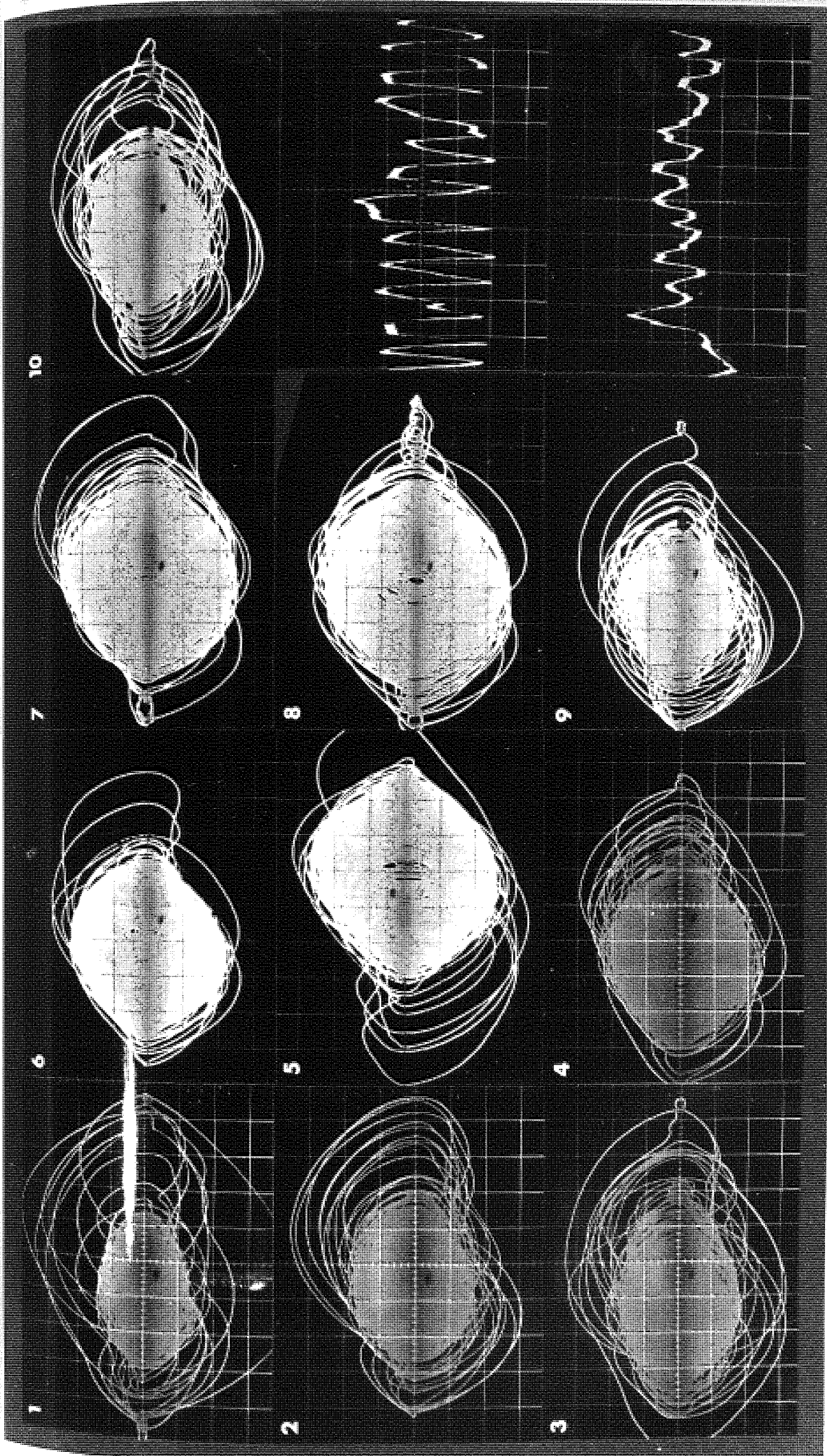

Figure 2.102

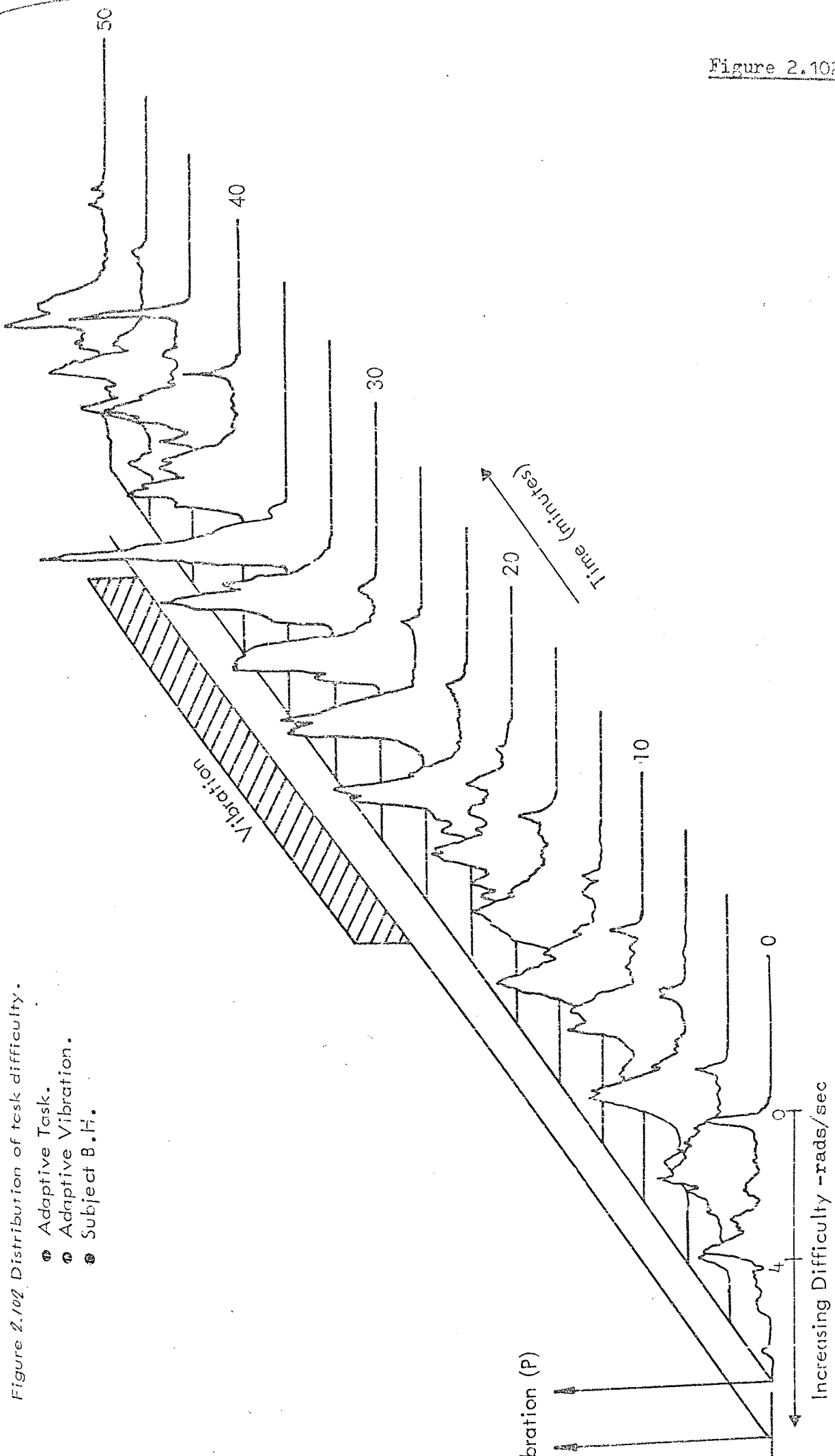

Figure 2.102 Distribution of task difficulty.

whatever on how to control. In keeping with the previous experiment the feedback given by the experimenter, in Expt.I, was omitted. On this occasion the subject was not informed that his control was in any way linked to the vibration.

The result of his practice and first trial period are shown in Fig.2.102. The probability distributions shown, although labelled task difficulty, serve also to describe the distribution of vibration Rms'g' value, when vibration was present, because the two variables were the same. Throughout analysis the epoch was again 200secs.. The first six distributions in Fig.2.102 and the next 2.103 refer to the practice session and the last ten to the first trial. Immediately it is noticeable, in Fig.2.102, that the subject developed a consistency which lasted until the middle of the vibration period. The consistency is shown by the progressive rise in peak probability and eventually by the full retention of control. Loss of control in Fig.2.102 is indicated by the sharp peak on the right hand side of the distribution at zero task difficulty. The eleventh and twelfth distribution have no such peaks indicating that there was no loss of control during those epochs but several losses during the 14th. The distribution of control movements in Fig.2.103 provides more evidence of progress but of another kind. It shows development of a bang-bang movement strategy. Development of the strategy begins at the start of the first trial period; it is evidenced by a progressive hollowing out of the distribution at the centre of the movement, an effect which becomes clear when the figure is viewed along the diagonal from bottom left to top right with the bottom left corner nearest the eye and raised 6" relative to the far corner. At the start of practice there is some likeness between the distribution of the input command signal (shown inset in Fig.2.103)

Figure 2.103

Figure 2.103 Distribution of Control Actions.

- Adaptive Task.
- Adaptive Vibration.
- Subject B.H.

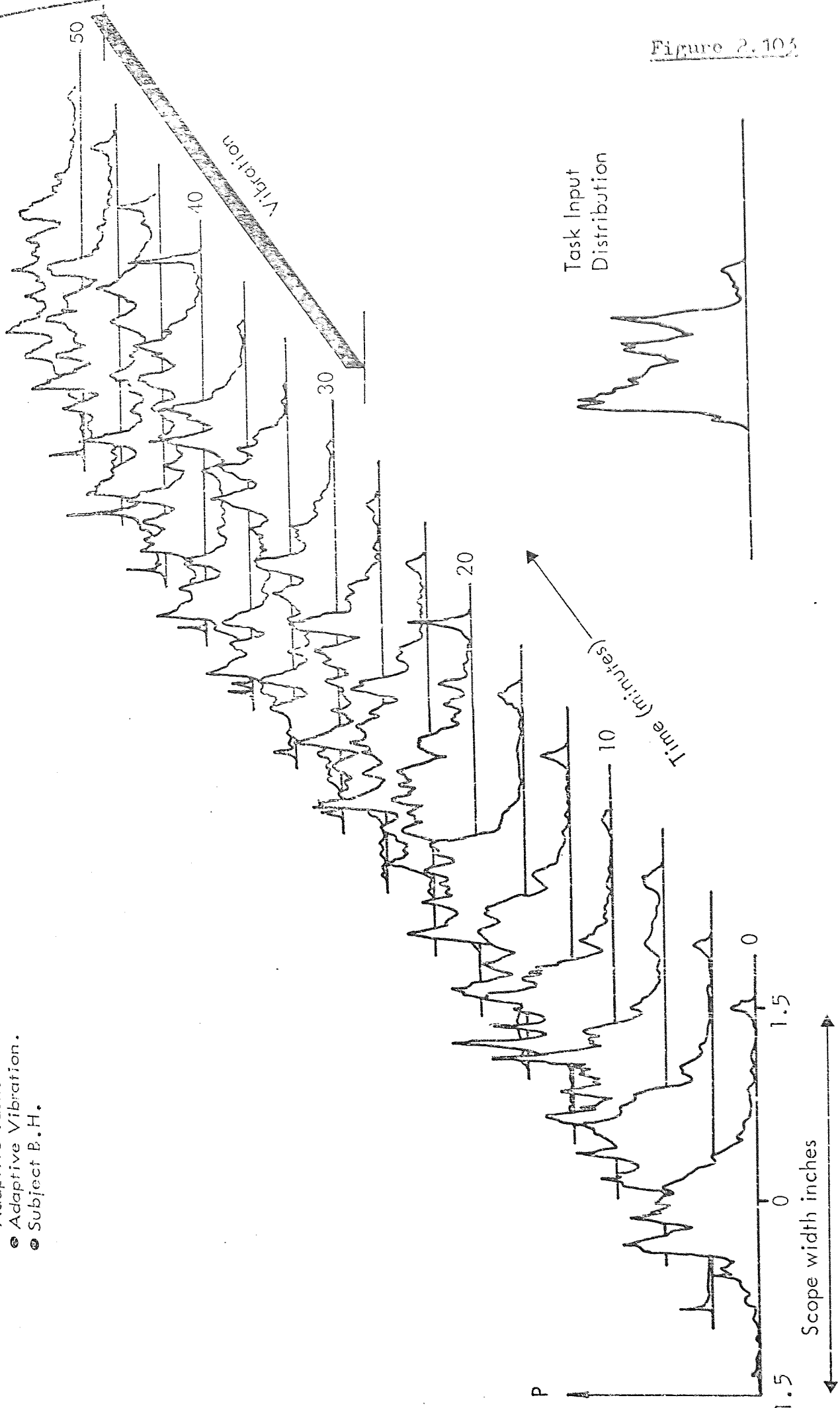

Note: Epoch's 1-6 are Practice; 7-16 are 1st Trial

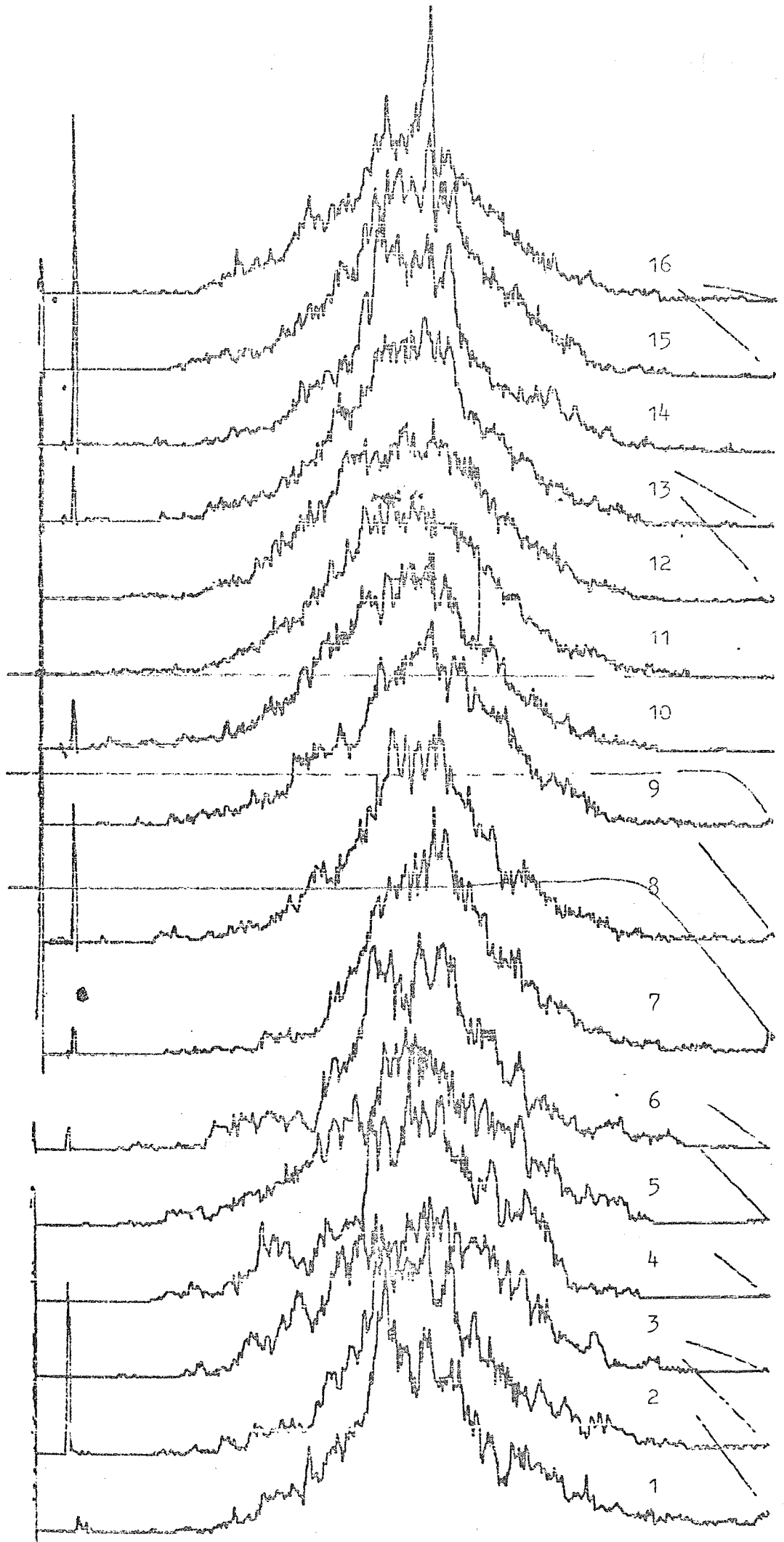
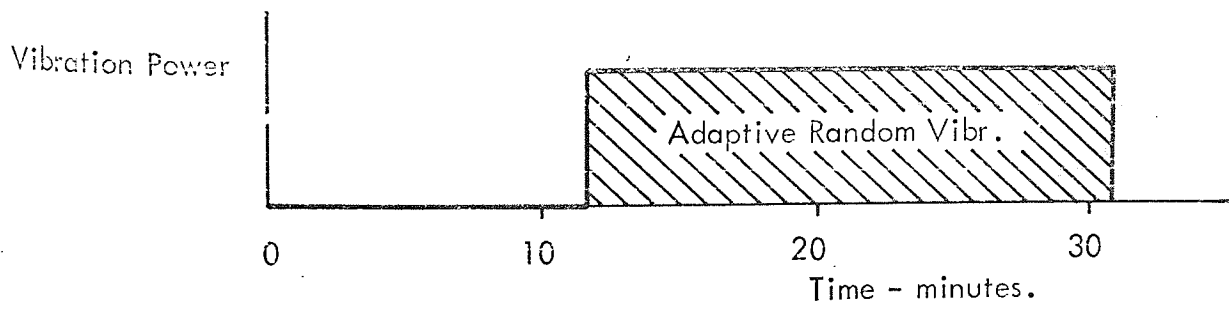
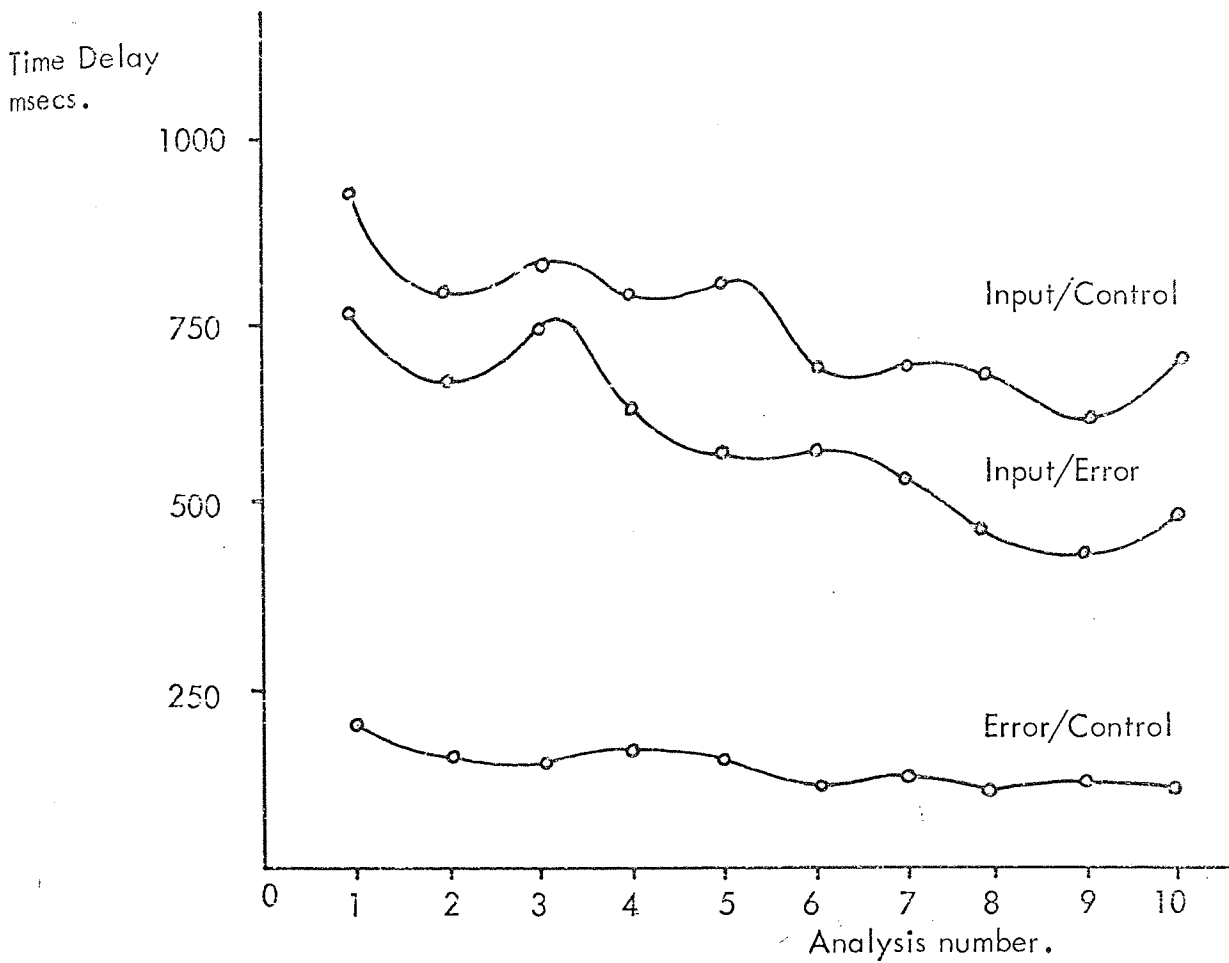

Figure 2.105 Subject B.H.  
Adaptive Random Vibration.  
Time Delay Analyses.

Figure 2.105





An Enlargement of the 1st 60 secs of each epoch in fig.2.106 showing the pattern of Phase Plane Trajectories.

Figure 2.107

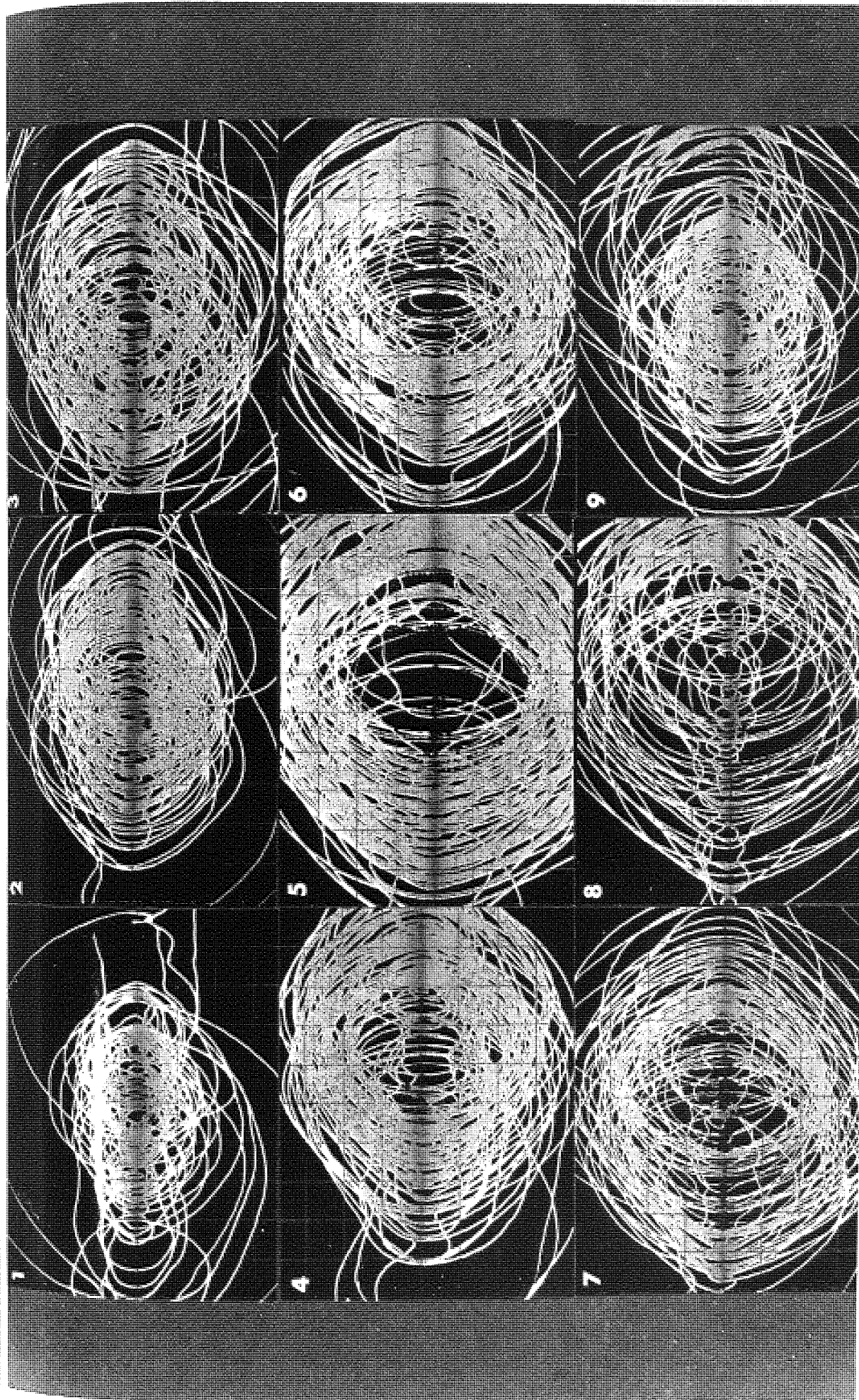



and the control action distribution. This indicates that the subject at the beginning was striving to comply with the error minimisation part of his objective an objective which the control movement distributions show was slowly abandoned in favour of the second part which asked that the line be kept on the scope. But the distribution of line position on the scope face in Fig.2.104 indicates that he was no more successful in confining the movement of the line with the bang-bang technique. This is not surprising because it was the function of the adaptive logic to keep the mean modulus of error constant. What then did this strategy achieve and why was it developed?

These questions have to some extent already been answered during discussion of the first experiment but will be considered again for this one individual who was subject to adaptive random vibration.

Fig.2.105 is the result of time delay analysis between the task variables for the first trial period ie. the last 10 epochs in Figs.2.102 and 2.103. The bang-bang strategy in this figure began to develop during the second analysis epoch and continued to develop up to the 7th./8th. epoch. This process of development is seen as a progressive reduction in time delay up to the 9th. epoch which does not appear to be significantly influenced by the presence of vibration although there was some retrogression at onset. During the ninth and tenth epochs the well defined bang-bang policy was abandoned with what appears to be a return to the error minimisation part of the control criterion. This return is shown in the phase plane plots of control movement in Figs.2.106, 2.107 and in the Zero Crossing analysis in Fig.2.108. In Fig.2.106 the bottom of the two waveforms refers to the control movement during the 10th. epoch, the upper waveform

Figure 2.108

Zero Crossing Analysis.  
Subject BH.  
Control Actions.

Vertical Scale- 1 inch approx 10 crossings

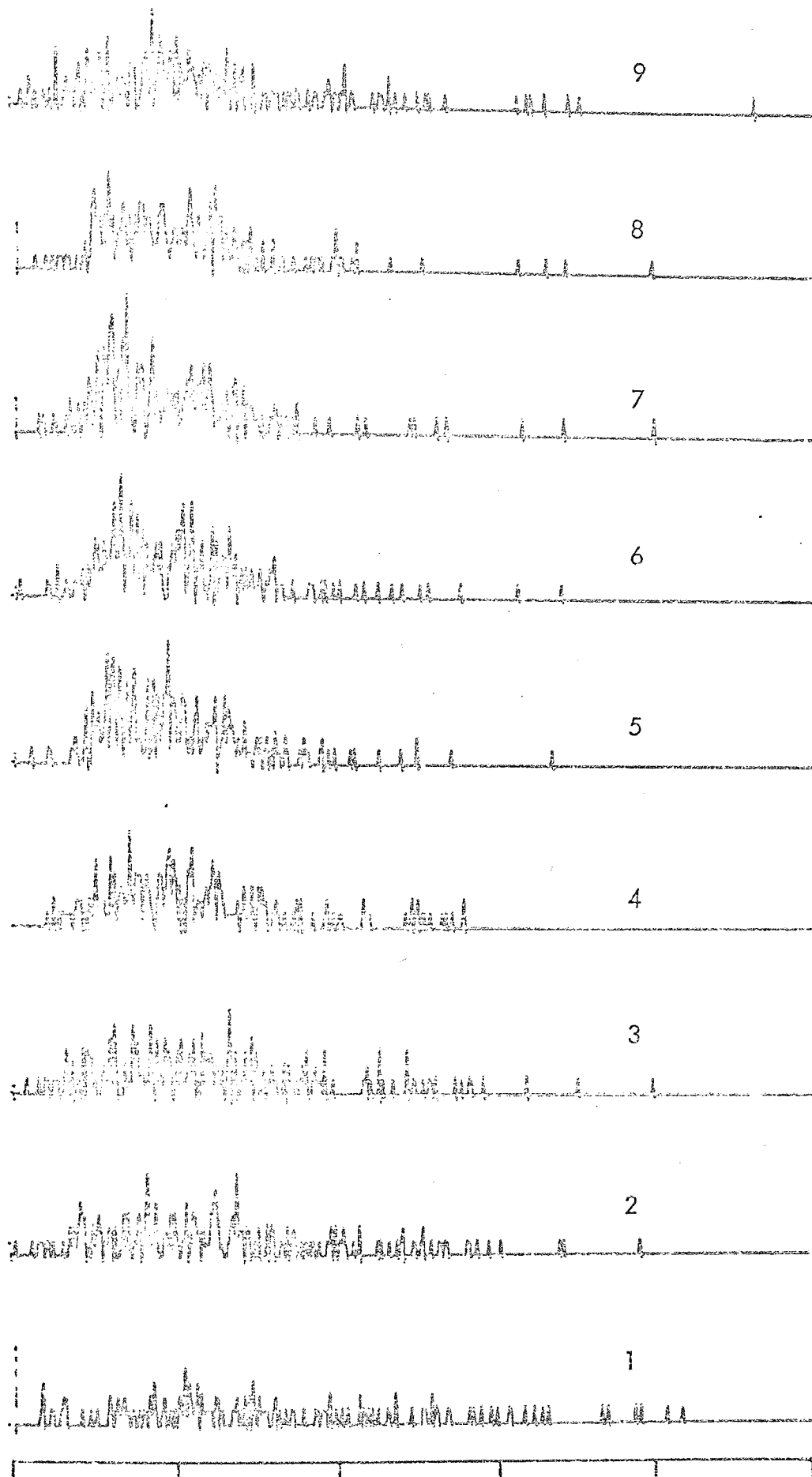

to the 8th. epoch. The return to more precise compensatory tracking is self evident in the waveforms. It is also self evident that bang-bang movement requires greater effort and energy expenditure which is reason enough for reverting to a more economical control technique. The pattern of effort during the first trial period is shown in the power spectrum of control movement, Fig.2.109.

During epochs 7 and 8 control effort is shown to have risen, an effect not clearly shown either in the phase plane photo or the zero crossing analysis but clearly shown in the phase plane analysis in Fig.2.110. Concomitant with this rise in control effort there was a loss of consistency as shown by the fall in peak probability and spread of the task difficulty distribution, at the 13th. and 14th. epoch in Fig.2.102. As a result of this increased effort, task difficulty was able to rise due to improvement in response time as shown in Fig.2.105. There seemed no logical reason why the subject should want to increase his effort at a time when he was most consistent in his performance and the vibration most stationary. Questioned about this some time after the experiment the subject recalled that during vibration it occurred to him that vibration and control actions were linked. To confirm this he remembered experimenting with control movements and put his rise in effort down to this.

In Fig.2.109 development of bang-bang movement is evidenced by the rise in power (relative to other frequencies) around 1Hz. (6-7 rads/sec.). The pattern of correlated power between display and control movement, Fig.2.111, rises very little as a result of the increased effort during the 7th. and 8th. epochs but it was a clear maximum during the third epoch.

Figure 2.109

Auto Spectrum  $G_{cc}$  of  
Control movement for  
the 1st Trial period  
of Subject BH.

G. D. WHITEHEAD

(Adaptive Random Vibration)

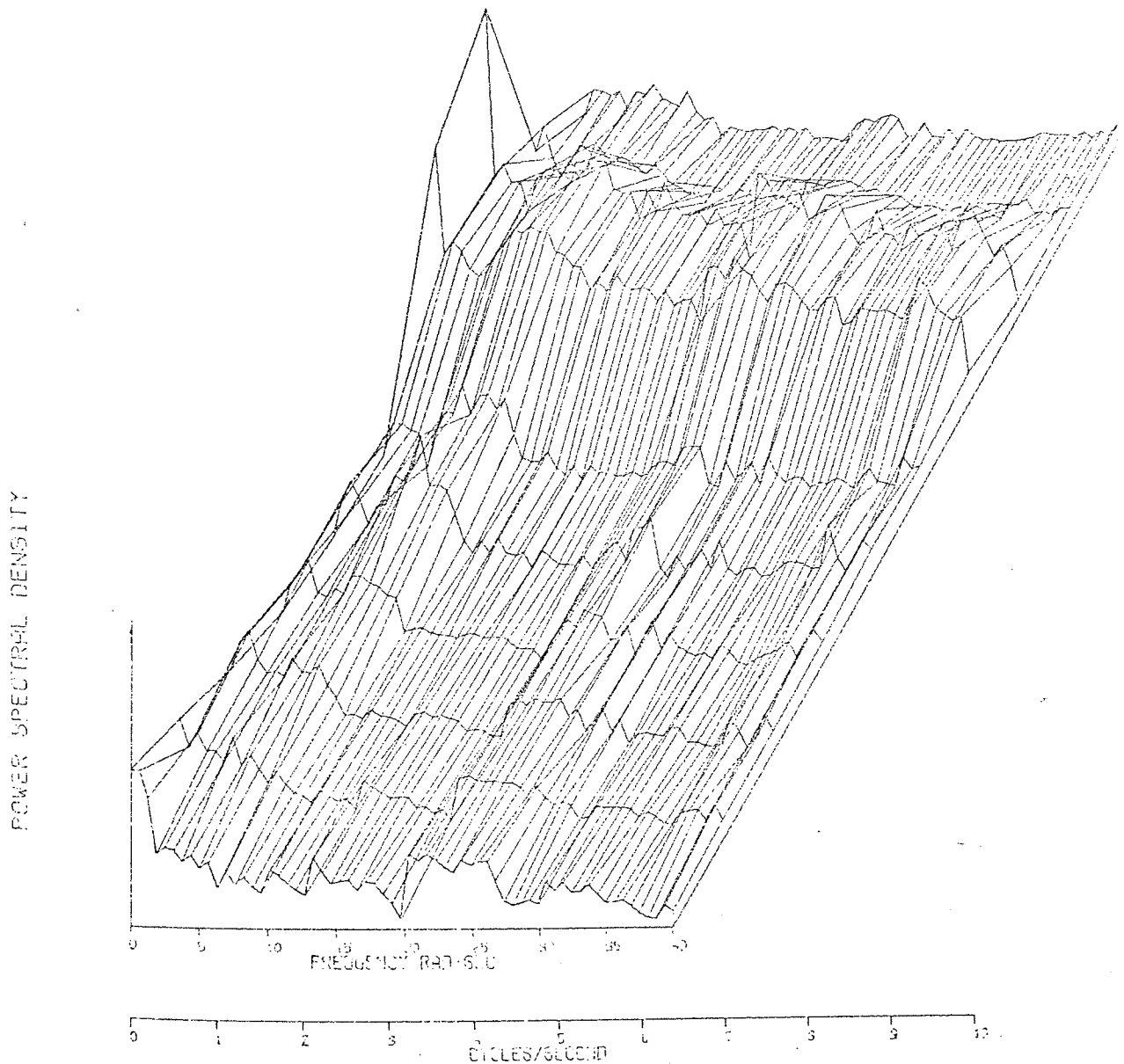

Figure 2.110

Phase Plane description  
Control movement to be  
compared with Power Spectrum  
fig.2.109

( subject BH, Adaptive Random  
Vibration)

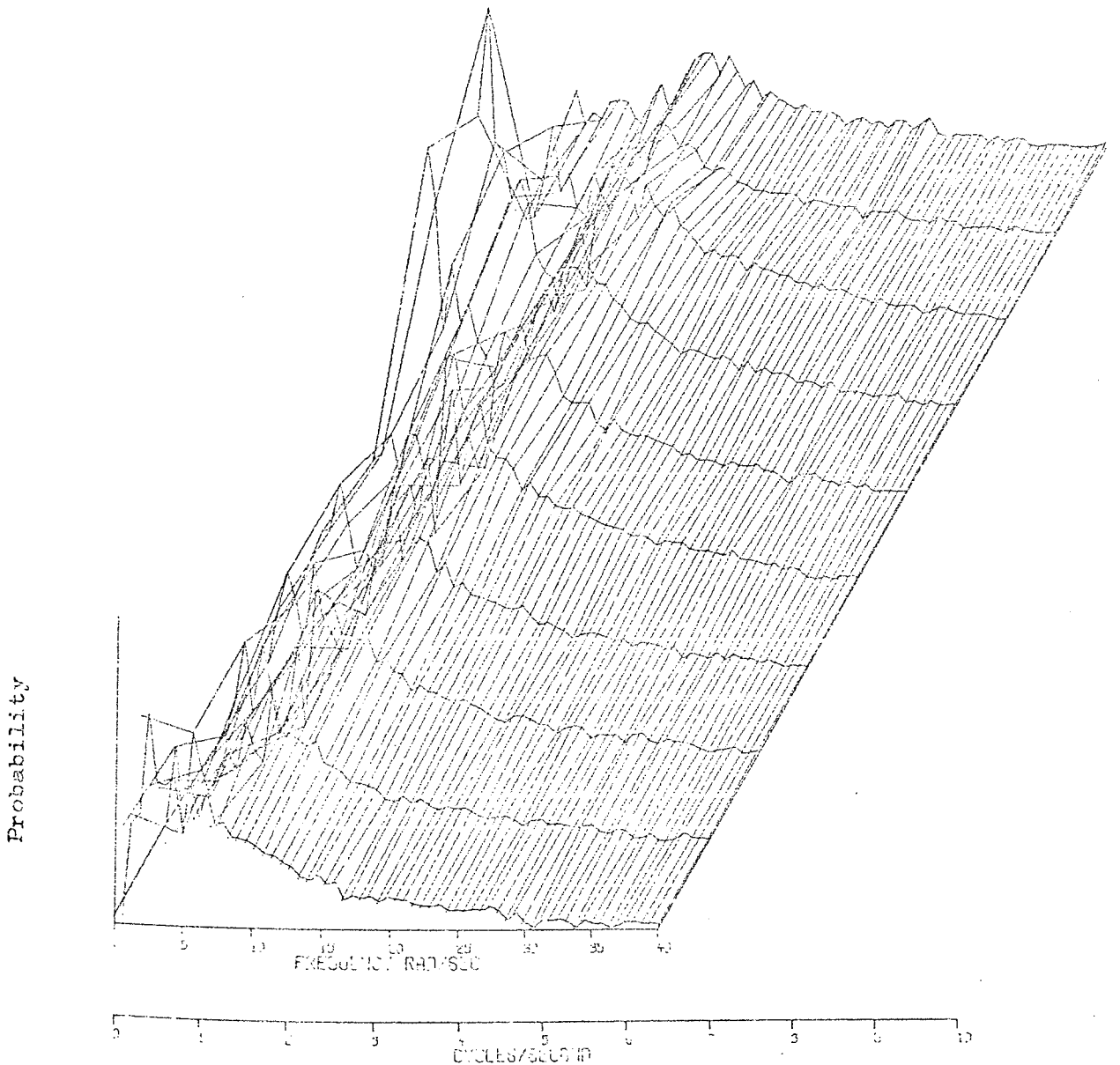

Figure 2.110a

An Inverted view of  
fig.2.110.

C. D. WHITEHEAD

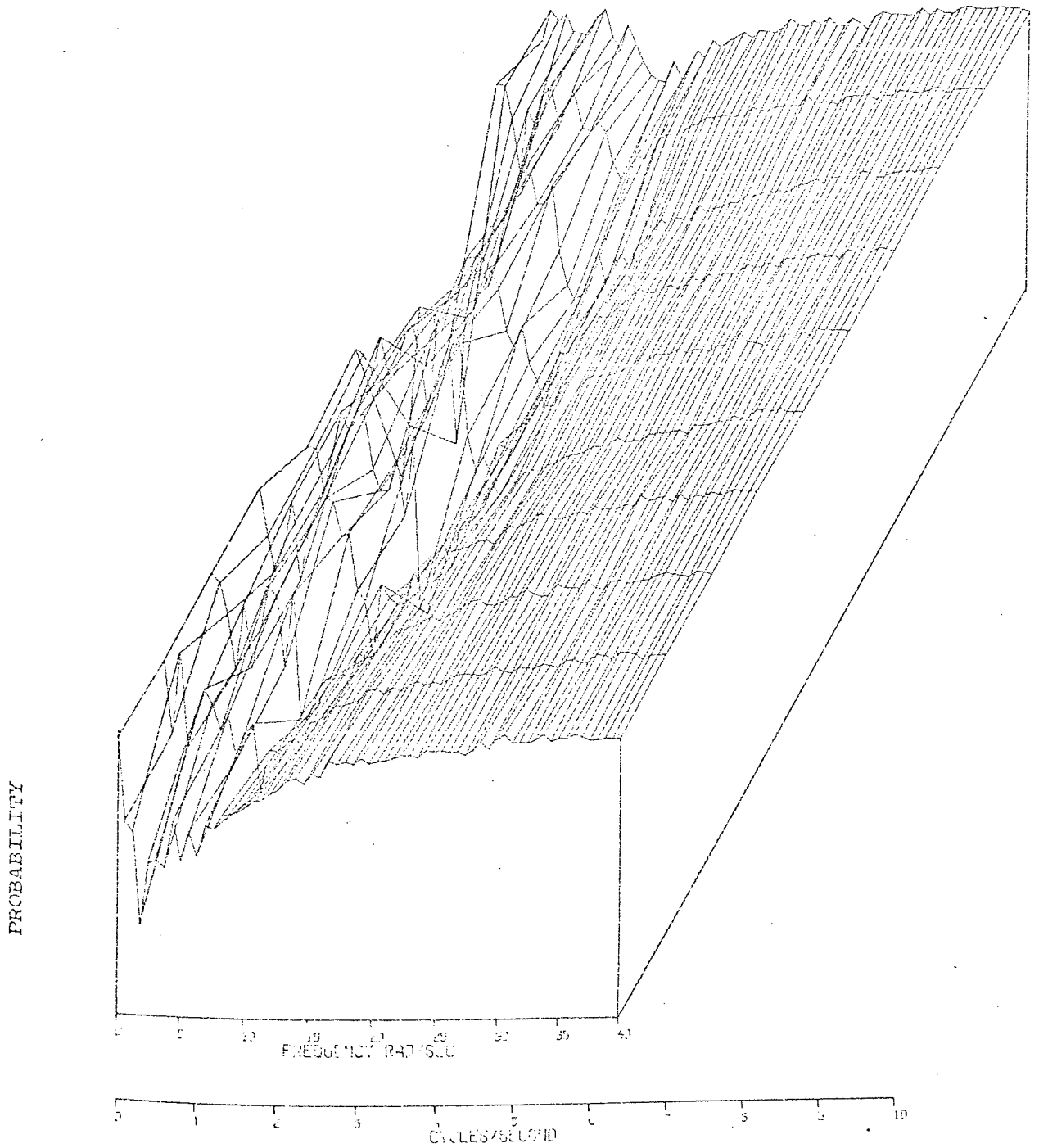
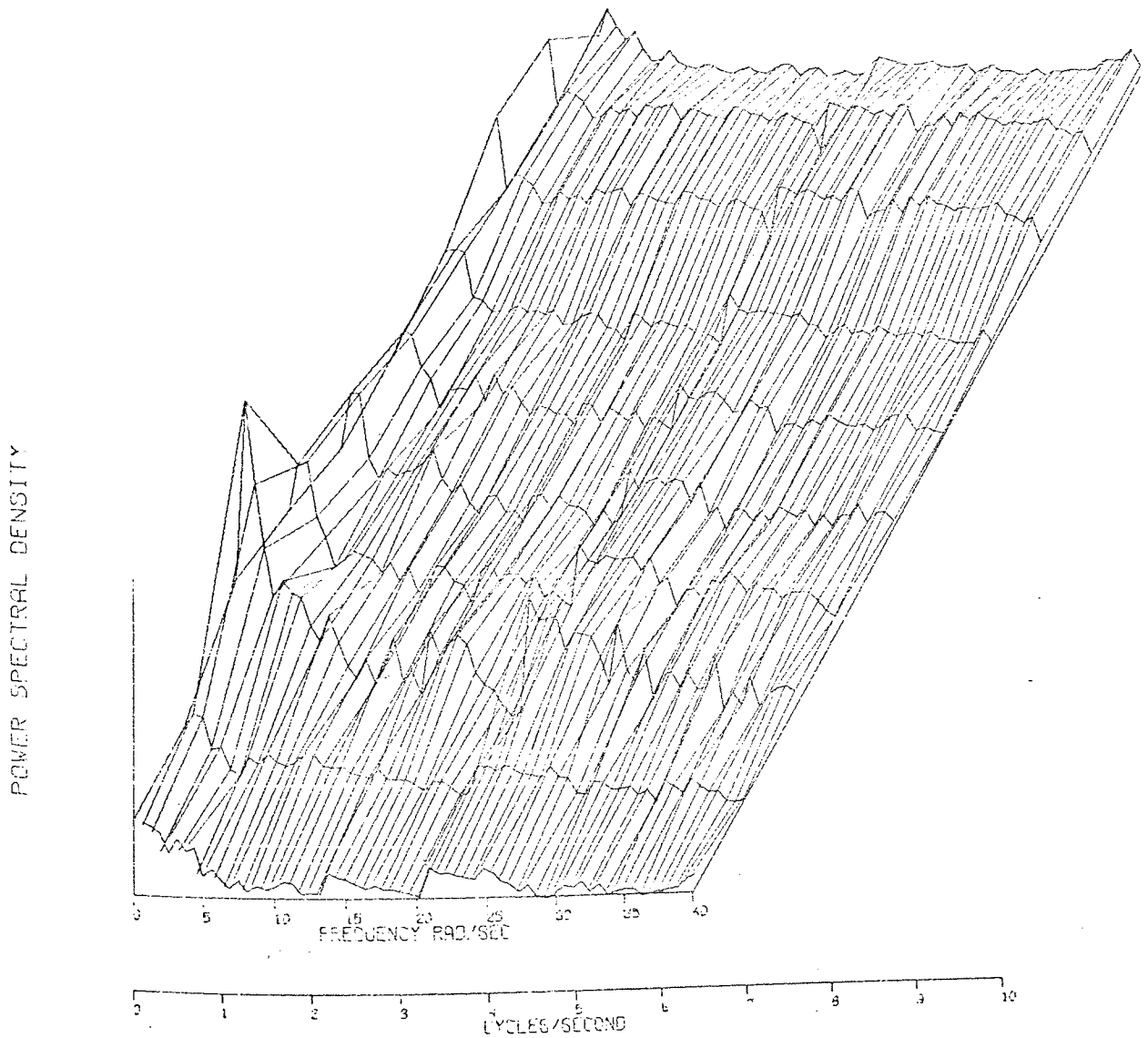

Figure 2.111 Cross Spectrum  $G_{ec}$  between G. D. WHITEHEAD  
Display & Control movem-  
ent for the 1st Trial  
period of Subject BH.  
(Adaptive Random Vibration)



Ideally the trajectory of bang-bang movement in the phase plane should comprise equal and opposite parabolic segments according to the equation :

$$\frac{d^2x}{dt^2} = \frac{Fx}{2m} \quad 0 < t < t_1$$

as shown below where  $F$  is a constant force applied to the control,  $m$  is the mass or inertia of the control,  $x$  its displacement and  $\dot{x}$  its velocity.

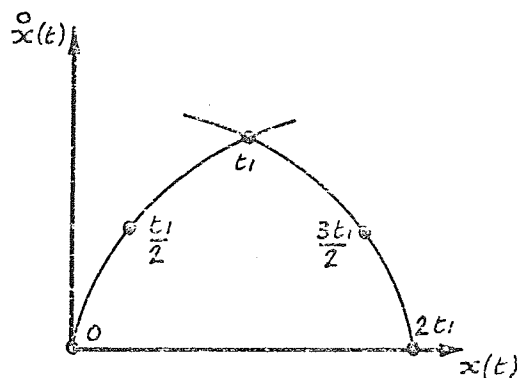

Evidence that the subject was operating near his ideal is contained in the phase plane trajectories of his control movement in Figs.2.106 and 2.107. The plots in 2.106 are his movement trajectories over the full epoch. The trajectories in 2.107 which are an enlargement of the central regions in 2.106 represent the first 60secs. of each epoch. The abscissa in these diagrams is the control displacement and the ordinate its velocity which was halved in scale. Bang-bang movement was used mostly during epochs 4-8 but the parabolic form is most noticeable in the 5th. epoch. In these plots there is little evidence of the 'left justified' technique having been used, a finding confirmed by visual inspection of the records, a sample of which for epoch no.5 is shown in Fig.2.112. Comparison between this and Fig.2.113, subject T.H., reveals that the present subject was less energetic in his hand movements and far from fully accomplished in the bang-bang technique.



Input Command Signal

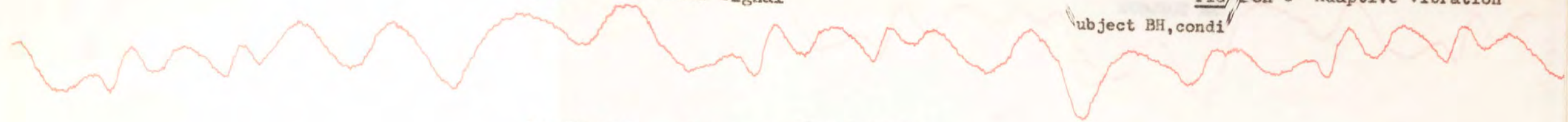

Error or Display Movement Signal

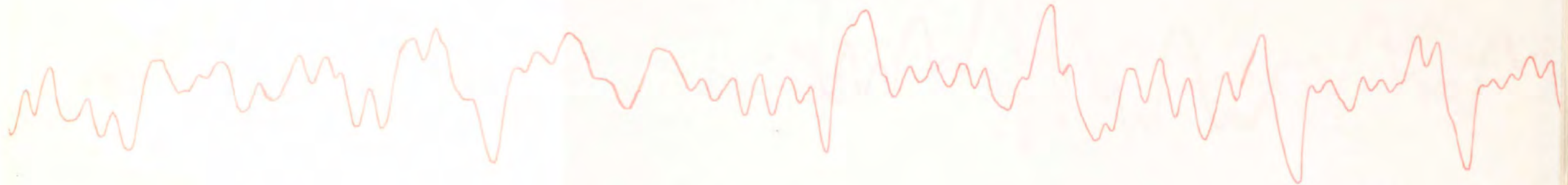

Control Movement Signal

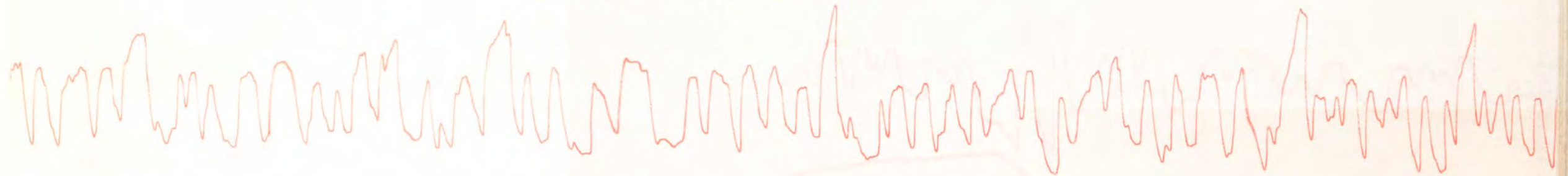

Adaptive Variable



operators chance of retaining control but at the cost of energy expenditure.  
 In terms of control effort it is not an economical technique and was thus  
 readily abandoned for a more economic method from time to time. The  
 technique has other virtues which were detailed in section 2.6. which  
 further justify its development.

It is recommended that further study of the technique should seek to



FIGURE 2.113

SUBJECT RM - Condition 'A'

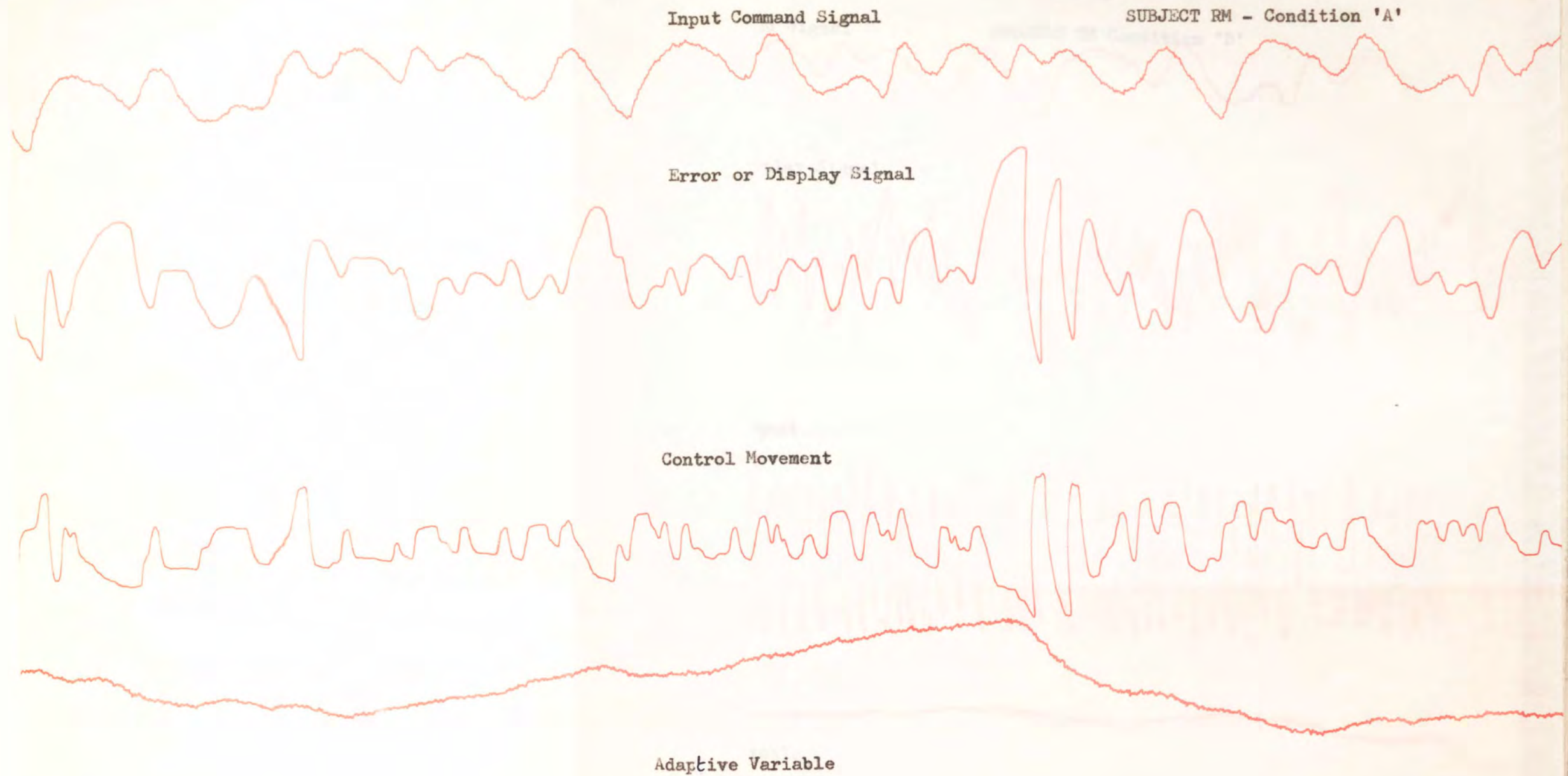

operators chance of retaining control but at the cost of energy expenditure. In terms of control effort it is not an economical technique and was thus readily abandoned for a more economical method from time to time. The technique has other virtues which were detailed in section 2.6. which further justify its development.

It is recommended that further study of the technique should seek to



FIGURE 2.113  
SUBJECT TH Condition 'B'

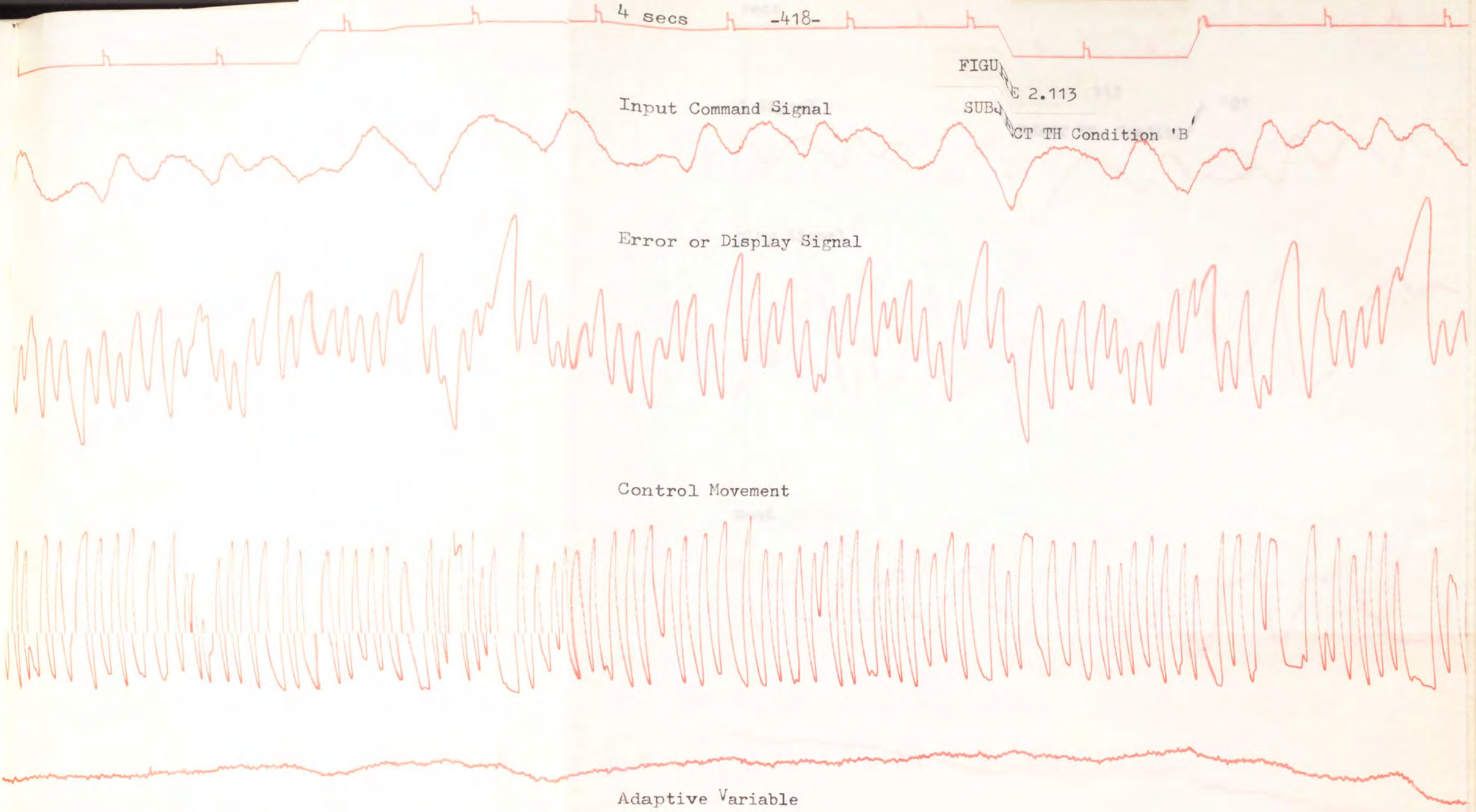

operators chance of retaining control put at the cost of energy expenditure.  
 In terms of control effort it is not economical technique and was thus  
 readily abandoned for a more economic method from time to time. The  
 technique has other virtues which were detailed in section 2.6. which  
 further justify its development.

It is recommended that further study the technique should seek to



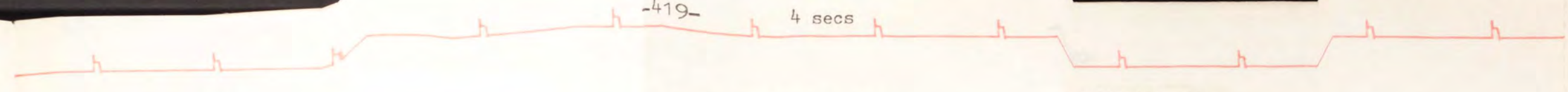

Input Command Signal

FIGURE 2.113

SUBJECT KD- Condition



Error or Display Signal

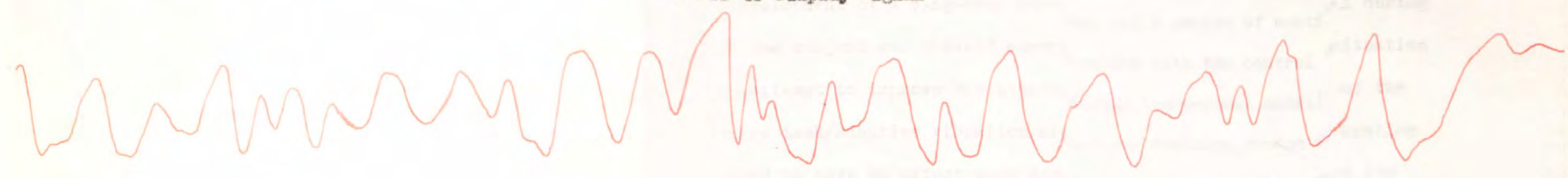

Control Movement

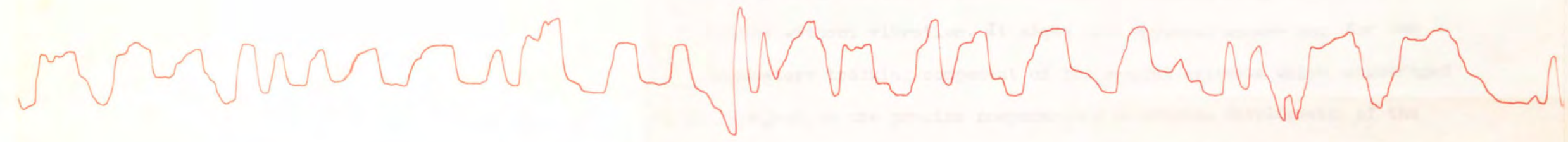

Adaptive Variable



operators chance of retaining control but at the cost of energy expenditure. In terms of control effort it is not an economical technique and was thus readily abandoned for a more economical method from time to time. The technique has other virtues which were detailed in section 2.6. which further justify its development.

It is recommended that further study of the technique should seek to



2.8.1. Summary and Conclusion.

Analysis of the control behaviour of one skilled subject has uncovered the development of a bang-bang strategy and a period of control during which the subject was himself experimenting with the control situation in an attempt to improve his understanding (conceptual model) of the adaptive task/adaptive vibration situation. Adaptive random vibration appeared to have no effect upon development of the strategy but its association with control movement caused the subject to experiment.

The bang-bang strategy began to develop 35 minutes after the start of practice without vibration. It might have appeared sooner but for the compensatory tracking component of the control criteria which encouraged the subject to use precise compensatory movements. Development of the technique was still continuing 27 minutes after its initial appearance and it is evident that in this subject there was scope for further development because there was no evidence of the 'left justified' refinement that was found in more practiced subjects.

The principal reason for its development is linked to the nature of the unstable element which comprised the control task. For this, the movement-time minimisation benefit derived from the technique maximises the human operators chance of retaining control but at the cost of energy expenditure. In terms of control effort it is not an economical technique and was thus readily abandoned for a more economical method from time to time. The technique has other virtues which were detailed in section 2.6. which further justify its development.

It is recommended that further study of the technique should seek to



understand the criteria used by the brain in choosing the force applied to the control and in choosing the time to reverse its application. In Servomechanics there is in existence sufficient theory to provide guidelines for the study and modelling of switching behaviour. From these studies it is clear that the ideal bang-bang model needs to be revised for the human operator to include difference in ballistic accuracy between movement to the right compared to the left and a stochastic element should be added to describe the uncertainty associated with the terminus of movement related to the target position. A model based upon the analogy of a relay or 3 mode switch was proposed by Young and Meiry (1965) who also estimated the switching line slope of operators using the bang-bang technique to control a similar unstable element. Since the major contribution of the operator is the provision of lead equalisation Young and Meiry reasoned that the model should contain an element for this function, a remnant term to account for uncertainty in triggering of the switch plus the normal human operator dead-time delay. To provide their model with the parameters needed to relate switching of control movement to the error signal and its rate the authors defined a switching line as a locus representing switching points where the operator intended to switch and carried out an analysis of control records to measure the slope of this line. At  $\lambda = 1.0$  rads/sec. they found that the slope was  $-8$  degrees and at  $1.7$  rads/sec.  $-25$  degrees. The slope was correlated with Rms error so that the larger the negative slope the greater the error in tracking. This study by Young and Meiry has provided some description of bang-bang behaviour but their concept of what is involved now requires extension to take account of refinements found in this study and the uncertainties in the control technique require to be evaluated.



2.9.0. Appraisal I. On the Effect of Whole Body Vibration on Manual Control Performance.

A review of studies on the effect of vertical vibration on performance was presented in Section 2.4. The review examined what were termed Simulation, Related Random Vibration, Sinusoidal Vibration and studies of random versus sinusoidal effects. The review concentrated on an examination of research involving realistic rather than abstract control tasks but abstract studies were consulted in order to help explain certain findings associated with the 'realistic' studies.

The results of the review were presented in graphical form, Fig.2.16, showing the percentage decrement or increment in performance relative to the no vibration condition associated with each control task against Rms'g'. There emerged a pattern of difference in decrement within and between the tasks studied and it was concluded that between tasks differences in % decrement were largely the result of differences in difficulty between control tasks and that within tasks differences in decrement caused by increment in vibration intensity were the result of vibration-added-difficulty. There was a trend towards higher rates of decrement with Rms'g' in those studies where the average decrement was largest suggesting that the more difficult a task the more sensitive performance would be to changes in Rms'g'.

The review revealed also that there was no differences in performance decrement between stationary and non-stationary random vibration and similarly that random and sinusoidal vibration equated on the basis of Rms'g' were no different in their performance effects. The first experiment reported in Section 2.6 confirms the former finding but not the latter.



The latter - equivalence between Random and Sinusoidal vibration was studied in the second experiment, Section 2.7 but in terms of vibration - added task difficulty at frequencies between 2-15Hz. there was no equality in terms of Rms'g'. The review study showed that random vibration tended to have a greater effect below 0.1Rms'g'. Experiment I fortifies this with the finding that between 1.3 and 10 times the Rms'g' intensity of sinusoidal vibration were required to produce the same effect on task difficulty. Sinusoidal vibration at 5Hz., 0.28Rms'g' was equivalent to 0.155Rms'g' of Random vibration whose power was concentrated in the range 3-16Hz. At 2Hz., ten times the Rms'g' of random vibration was required to produce the same effect on task difficulty.

The task used in this research to study vibration- added difficulty was adapted so that at all times it was at a level of difficulty near to the critical threshold for the individual operator. When performing the normal compensatory tracking function it revealed that random vibration added 33% to the difficulty of the task at 0.09Rms'g'. Because of its logic the adaptive task has the advantage that performance and difficulty are equated. In this case maximum change in performance occurs at 0.3 times the highest rate of change in the index of task difficulty caused by vibration i.e.

$$\Delta \epsilon_{MAX} = 0.3(\Delta \lambda)_{MAX}$$

where  $\Delta \epsilon$  is the increment in error associated with a change in difficulty  $\Delta \lambda$  per unit of time and 0.3 is the adaptive rate or gain. Relative to the standard of performance demanded by the adaptive task the added difficulty of 33% at 0.09Rms'g' was equivalent to an average increase in error of 48%. Because the adaptive task was close to the ultimate in difficulty at all times, this decrement places a limit on the decrement to be expected from



highly motivated operators in the range 0-0.09Rms'g' and this has been indicated as such in Fig.2.16 but it must be remembered that it refers to a one dimensional tracking task without secondary task loading. For 2D.Comp. tracking with secondary task loading the limit should however be little different because there is a limit to the information processing capacity of the human operator which was fully occupied at all times by the adaptive task.

Subjects in this study raised their effort and did all that they could to counteract the effects of vibration but in spite of this it was necessary for the logic to lower difficulty in order that their performance be kept up to standard. The added difficulty and its associated performance decrement refer therefore to maximum effort and would be greater if this intervening variable were of lower value.

Measures of vibration - added difficulty it is realised, are worthless to the system designer, job evaluator and manual control in general unless they can be translated into consequences for the system and consequences for the human operator. In this research, consequences for the system were expressed in terms of the maximum degree of instability that operators could handle. Human costs were demonstrated in terms of changes in the control function and physical control effort required to minimise the added difficulty but no measure of psychological cost or of the long term fatigue effects were obtained. The truism that psychological cost is important, cannot be stated or debated often enough. Not until we can measure it can we properly evaluate the operators efforts towards the minimisation of added task difficulty. With trends towards 'Technical Assessment' and Cost-Benefit analysis in system design knowledge of its



existence makes it an agonising omission. An agony which must be brought some relief by research efforts towards a practical and measurable concept but first an intellectually satisfactory concept must be found and agreed upon. If it is not the Human Factor in man-machine systems will never benefit from systems engineering to an extent worthy of its cost.

In Section 2.3.9.2. it was stated that the results of previous research "gave the impression that there was a threshold level of task difficulty and realism below which there is little or no effect and above which there is an effect in proportion to the difficulty which vibration adds to the task" Studies where performance decrement was shown to occur suggest that vibration added to the difficulty of the control task in linear proportion to  $Rms'g'$ . Experiment I does ratify this suggestion but the trend towards an increasing rate of task difficulty at the highest level of intensity  $0.09Rms'g'$ , for the adaptive task, infers no threshold for the difficulty of the task below which vibration would have no effect.

In Experiment 1 there is no doubt that added task difficulty due to vibration was caused primarily by vibration interfering with the operators intended control actions combined with a slight effect due to loss in accuracy of target sighting. This was evidenced by correlation between vertical vibration at the seat compared to lateral vibration at the control box between which there was a resonant condition but it was an effect which some subjects overcame by increasing their amplitude of control movement and under certain control criteria by adopting a bang-bang control policy which had the effect of masking not only part of the task input signal but spurious movements of the control box caused by vibration.



Experience in coping with vibration showed through in the adaptive task scores by the addition of less difficulty at 0.09Rms'g' in the case of the more skilled subjects. This confirms the finding of Harwood et al. (1968) who found that professional pilots were able to perform better than amateur pilots although the difference between them was not as large as expected. On the adaptive task at 0.09Rms'g' vibration added 29% to task difficulty for the most skilled subject and 54% to the difficulty of the least skilled subject at a lower level of vibration.

Analysis of vibration transmitted through the body from seat to head during performance of the control task indicated an increase of between 9 and 11db. at the resonant frequency of the subject on the seat. This resonant frequency was the same as that found by authors in the review study but transmissibility was 3-5db. higher because no body restraint was used during the adaptive task.

Previous assessment of vibration based upon reviews of research have tended to ignore the distinction between primary control tasks with and without secondary loading tasks. The recent review by Grether (1971) is an example where this was done. Grether concluded that a number of positive generalisations can be drawn concerning the effects of vibration on human performance. He concluded that vibration causes impairment of human tracking ability proportional to vibration amplitude and is greatest at very low frequencies; that is, below 5Hz, and that other tasks that require steadiness or precision of muscular control are likely to show decrements from vibration. He concluded also that tasks that measure primarily central neural processes such as reaction time, monitoring and pattern recognition appear to be highly resistant to human performance degradation



during vibration. When vibration is random as it was in the majority of studies reviewed in Section 2.4. the intensity of vibration must be expressed by statistical description, for example Rms'g'. On these and on intuitive grounds there can be no disagreement with Grether that impairment is proportional to vibration amplitude but the results of Experiment II using sinusoidal vibration appear to disagree strongly with his view that impairment was greatest at frequencies below 5Hz. Experiment II showed that most difficulty was added to the task in the region around 5-6Hz. with higher additions above 6Hz. in this region than below it and with ability limited by tolerance at 8Hz. and above. This finding agrees with Shurmer (1967) who, referring to the limiting factor on acceleration levels stated that 'below about 10c/s. the limit is determined by tracking performance and above 10c/s. by endurance considerations'. Grether's conclusions concerning tasks that measure primarily central neural processes etc. was largely confirmed by this review but the review indicated that time sharing ability is adversely effected when the secondary task involves fine manual adjustment.



2.10.0. Appraisal II. On the Adaptive Task Technique.

The adaptive task technique was used because of advantages pointed out by C.R.Kelley. Experience of the technique in this study has been very encouraging. The technique did indeed separate the range of individual difference in skill level between subjects in Experiment I and proved to be an economical and reliable method of assessment. It is not known whether it was a more sensitive method of assessment because no non-adaptive equivalent was used with which to compare it. Nevertheless it is unlikely that any other method would have been more sensitive and in any case it was optimal from the point of view of the task studied because without adaptation to the individual, performance of the task would often have been impossible. Implementation and development of the adaptive technique undoubtedly increased the time taken to set up the experiment but the on-line presentation of results and lack of fuss in dealing with individual difference in skill and the built in training facility that it provided, it was felt, more than repaid the development time that was invested. Because of the adaptive logic the training given to each subject was identical, a feature which enabled the experimenter to leave the experiment in the charge of an assistant confident in the knowledge that the conduct and the results of the trials and training would be the same no matter who was in charge.

The adaptive technique has the advantage that it prevents misconceptions about the measurement of performance and prevents the collection of useless data because without a full preconception of the performance measure there can be no adaptive logic and no implementation of the technique. It is a research technique which must inevitably find increasing favour with



the advent of the small on-line digital computer. The adaptive logic which was used in this study was very simple compared to the logic that could be developed given a digital facility. But simple logic means simple interpretation and the highly conditional logic which is feasible on a digital computer will require careful consideration if the end results are to be interpretable by persons other than the programmer. The adaptive task technique by analogy with adaptive training is a form of experimenter simulation. Often research involves the strategic manipulation of variables in an attempt to establish relationships, to discover truths, to test hypotheses and to reach understanding. The adaptive research technique, if and when used to stimulate a research worker has the advantage that it can provide a formal chronicle of strategies, tactics and adaptive criteria that were used to accomplish the research goals.



2.11.0. Appraisal III. On Waveform Analysis.

Motivated by the widespread use and evident importance of waveforms in research coupled with a general lack of formalism attached to the selection of descriptive alternatives a formal structuring of the waveform description problem was carried out in Part I. As a result fundamental consideration was given to the types of description possible, to the dimensions of description, to features and events, occurrence relationships and the temporal structure of waveforms. In particular fundamental consideration was given to the nature of frequency and its detection and a novel method of detection and description based upon an analysis of the phase plane trajectory was developed. Methods were reviewed for the detection and description of patterns of occurrence and the value of visual pattern recognition was emphasised.

Part II provided an opportunity to apply the formalism and techniques developed in Part I to the description of vibration and control behaviour. In order to provide an almost complete description within and between waveforms resulting from the experiments in Part II seven types of analysis were carried out to provide adequate coverage of the waveform dimensions and their temporal structure. Spatial structure was described by amplitude probability, zero crossing, power spectral density and phase plane analysis. The order or syntactic structure was described by autocorrelation and the non-stationary structure by a moving average Rms description and short time averaging of the spatial and order structure descriptions. The spatial/order structure between waveforms was described by cross spectrum and cross correlation analysis. A major omission from this battery was the provision of a joint occurrence description between the



error and control movement variables associated with the adaptive task. Had this been carried out much more could have been said about the nature of the bang-bang control technique which was developed by subjects. By providing alternative views to the same thing the different analyses were able to highlight the dimensions along which changes in control behaviour were taking place and in most cases were able to describe the nature of change. Comparison between the amplitude, zero crossing and power spectrum analyses provided a very complex picture of the nature of control movement, correlation or time delay analysis of the order within and between waveforms and cross spectrum analysis of linear correlation of frequencies between waveforms corrected on the basis of aggregate time delays. The value of each description and the success of the phase plane analysis technique were dealt with in Section 2.6.13. and the waveform analysis considerations which entered into the experimental design were given in Section 2.6.2.

When considering and preparing for waveform analysis care must be taken to ensure that the amount of waveform data collected is kept in proportion to the computing power and the analysis time available.

It is also important to check that the data can be efficiently input into the computer and that the capacity of its backing stores are sufficient to accommodate the digital equivalent of the analog records. Few large computer installations are equipped for analog-digital conversion with the result that data has to be input either on card, punched paper tape or transferred indirectly by some other means to computer compatible magnetic tape. The latter approach was adopted for the purpose of this study but failed because the digital tapes produced were wrongly coded. Thus it became necessary to revert to the production of punched paper tapes which because of the time



taken resulted in serious curtailment of the analysis program, even so the full set of analyses presented took seven man months of effort to complete.

The technique used to derive the Phase Plane Angular Velocity was based upon the use of an I.R.S. 580 Digital Memory Computer and the program symbolized in the order of this number. A block diagram of the computer system is shown in Figure 11. The function:

$$\dot{\theta} = \frac{d\theta}{dt} \Big|_c \quad (1)$$

was approximated by:

$$\dot{\theta} = \frac{d}{dt} \left[ \frac{x(t) - x(t-\tau)}{\tau} \right] \quad (2)$$

The time delay  $\tau$  was generated by a 2nd order PDE approximation, i.e.

$$\tau^2 \frac{d^2 x}{dt^2} + 2\tau \frac{dx}{dt} + x = x(t) \quad (3)$$

The transfer function of the system which was low pass filtered at 100 cps, was generated by a critically damped second order system. The PDE was approximated by a fixed non-linear function generator. To evaluate the calculation a system of logic was used to derive the angle of the trajectory in the phase plane. This angle was finally differentiated by a third order system to give an estimate of the point normal angular velocity.

## APPENDIX A

## DETECTION OF THE POINT CENTRED ANGULAR VELOCITY IN THE PHASE PLANE

## 1. Analogue Technique

The technique used to detect the Phase Plane Angular Velocity was based upon the use of an E.A.L. 680 Parallel Hybrid Computer and the programme symbols to be used refer to this machine. A functional block diagram of the computation scheme is shown in Figure A1. The function:

$$\dot{\phi} = \frac{d \left[ \frac{d \left( \frac{dx}{dt} \right)}{dx} \right]}{dt} \quad \text{----- (A1)}$$

was approximated by:

$$\dot{\phi} = \frac{d}{dt} \left\{ \tan^{-1} \left( \frac{\dot{x}(t) - \dot{x}(t-\tau)}{x(t) - x(t-\tau)} \right) \right\} \quad \text{----- (A2)}$$

The time delay  $\tau$  was generated by a 2nd order PADÉ approximation, i.e.

$$e^{-\tau s} = \frac{1 - \frac{1}{2}(\tau s) + \frac{1}{12}(\tau s)^2}{1 + \frac{1}{2}(\tau s) + \frac{1}{12}(\tau s)^2} \quad \text{----- (A3)}$$

and the first time derivative of the waveform, which was low pass filtered on output, was generated by a critically damped second order system. The ARCTAN was approximated by a fixed non-linear function generation. To complete the calculation a system of logic was used to detect the angle of the trajectory in the phase plane. This angle was finally differentiated by a first order system to give an estimate of the point centred angular velocity.



In more detail, the first differential of the input waveform was generated by a second order system to allow the phase plane plot between the first and second derivative to be studied, as well as that between the zero order and first derivative.

A natural frequency of 80c/s was used for the second order system which was tuned to be critically damped. The major part of the tuning was achieved by scaling but the final trimming was performed using a step input and then observing the response of the system in the phase plane. This response is shown in Figures 13b and 13c of Part I of the main text. Figure 13c shows the response of the system underdamped whilst Figure 13b is the response near critical damping. The criterion for critical damping was no overshoot and the potentiometer in Figure A2a was adjusted to this condition. The natural frequency of 80c/s was chosen with reference to the highest frequency of interest in the waveforms to be analysed by this method which was 30c/s. 80c/s was chosen to give sufficient speed of response to the waveform across the spectrum of interest. It is recognised that the effect of the second order system is to distort, to some extent, an Applied waveform. The distortion is due to the time delay across the device which is proportional to frequency and its characteristic is well known, being approximately 0.40 ms at 80c/s. However, this distortion was ignored for the purpose of this study on the grounds that it is a fixed effect and therefore not relevant to the detection of difference between waveforms.

## 2. Scaling

The equation of motion of the second order critically damped system is given by

$$\ddot{x} + \frac{c}{M} \dot{x} + \frac{k}{M} x = 0 \quad \text{----- (A4)}$$

where  $\frac{c}{M} = 2\sqrt{\frac{k}{M}}$  for critical damping

and  $\frac{k}{M} = (2\pi f_n)^2$

where  $f_n$  = natural frequency 80c/s.

$$\therefore \ddot{x} + 1005.44 \dot{x} + 252727.398 x = 0 \quad \text{--- (A5)}$$

The time scale of the simulation is determined by the R.C. time constant of the integrators as follows:

$$\text{R.C. (secs)} = X(M\Omega) \times Y(\mu F) = 1/\omega = 0.00198 \text{ Secs.}$$

$$\therefore \text{let } R = 0.02 \text{ M}\Omega.$$

$$\text{and } C = 0.1 \mu F.$$

To scale the voltage for amplitude velocity and acceleration to limit these quantities to the available 10v., the amplitude scale unit will be 10v/V input since the input is from magnetic tape with a dynamic range on output of  $\frac{1}{4}$  IV.

$$\therefore Ax = 10 \text{ v/VOLT INPUT.}$$

$$A \dot{x} = \frac{10}{\omega x} = \frac{10}{502.72} = 0.01989 \text{ v/v/SEC.}$$

$$A \ddot{x} = \frac{10}{\omega^2 x} = \frac{10}{252727.398} = 0.0000395 \text{ v/v/SEC}^2.$$



To scale the equation of motion these scale units are applied so that

$$\frac{\ddot{X}}{A \ddot{x}} = - \left[ 1005.44 \frac{\dot{X}}{A \dot{x}} + 252727.398 \frac{X}{Ax} \right]$$

$$\therefore \frac{\ddot{X}}{\lambda} = - 3.95 \cdot 10^{-5} \left[ \frac{1005.44 \dot{X}}{0.01989} + 252727.398 \frac{X}{10} \right]$$

$$\therefore \ddot{X} = - 1.98876 \dot{X} - X \text{ ----- (A6)}$$

The programme segment which simulates this part of the detector is shown in Figure A2a. Subsequent segments of the programme are shown in Figures A2b and A2c. The timing diagram for the logic, together with a series of waveforms showing the stages of detection of the angular velocity for a sine wave are shown in Figure A3.

### 3. Digital Technique

The digital computer programme is written in ICL 1905 algol. It has been written to accept digital samples of a waveform sampled at equi-spaced intervals. The numbers are input to the computer on punched paper tape preceded by the specification of a number of computation parameters. Output is in graphical form. Four graphs are plotted showing the joint occurrence between amplitude and angular velocity, and one each for the distribution of angles in the phase plane, amplitude and angular velocity, examples of which are shown in Figures A4, 5, 6 and 7. Nine parameters must be specified in the following order:



1. Sample size: i.e. the number of numbers to be analysed.
  2. I: number of intervals of a histogram into which negative values of amplitude may fall.
  3. J: as above for positive values of amplitude.
  4. K: as above for negative values of angular velocity.
  5. L: as above for positive values of angular velocity.
- NOTE:  $(I + J) \times (K + L) \leq 5000$
6. Sampint: is the sampling interval for the data in seconds.  
NOTE: Sampint should normally have the value 1.0 because the graphs output have been scaled to this value.
  7. Voltrange: is the analogue to digital scale factor, e.g. a number on punched paper tape of 1000 which is equivalent to 1 volt requires a voltrange value of 1000.
  8. Dynamrange: is not optional in this version of the programme. IV should be made 1.0.
  9. Quad 3: is used as a logical variable. Quad 3 = 1.0 causes the programme to include a routine which smooths the phase plane plot and plots only the absolute values of angular velocity. Quad 3 = 0 ignores the smoothing and modulus routine.

The programme performs numerical differentiation and calculates the angle in the phase plane. As the processing of the data proceeds the first and subsequent angles calculated are modified by a routine which looks forward and backward to check the feasibility and assign a quadrant to the angle based upon a number of criteria. The most important criterion being one which restricts transition angles in the phase plane to a

difference not exceeding  $180^\circ$ . Joint occurrence between amplitude and angular velocity is detected by assigning the first number read in, to the first angular velocity calculated and so on.

Although not included in the main programme a phase plane plot of the digital waveform was accomplished by the ancillary programme which appears after the main programme. No parameters are required to be read in by the ancillary programme.



Block Diagram of the Hybrid Computer program for the Computation of Phase Plane Angular Velocity.

Figure A1

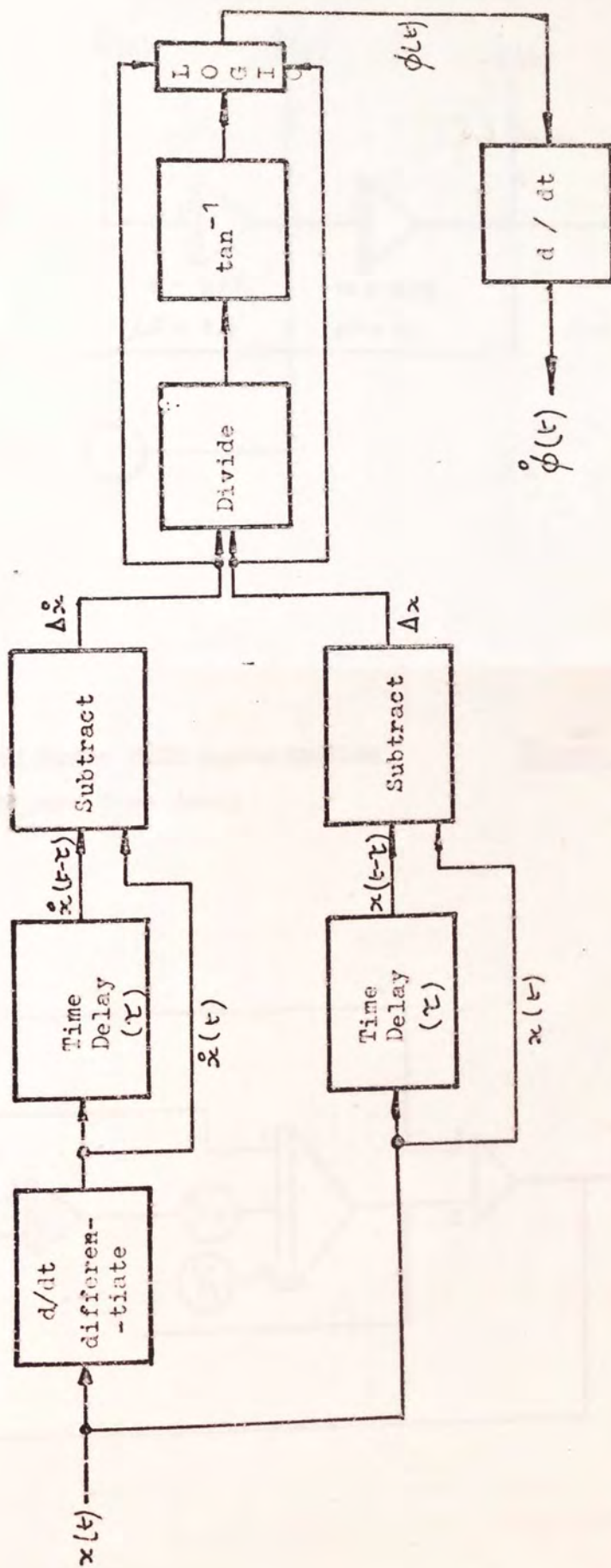



Program Segment for Differentiation

Figure A2a

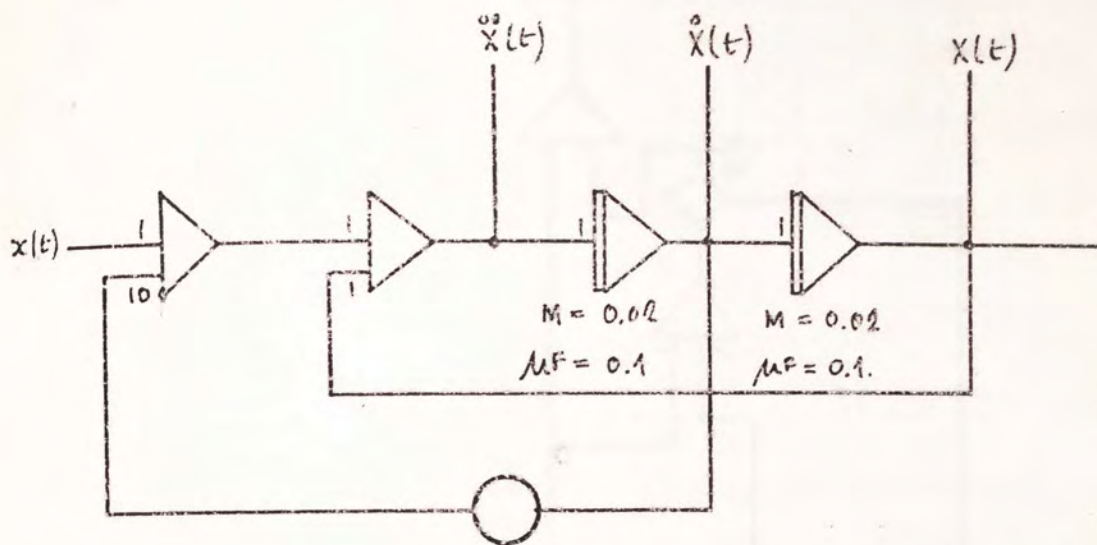

Second Order PADE approximation  
for a pure time delay

Figure A2d

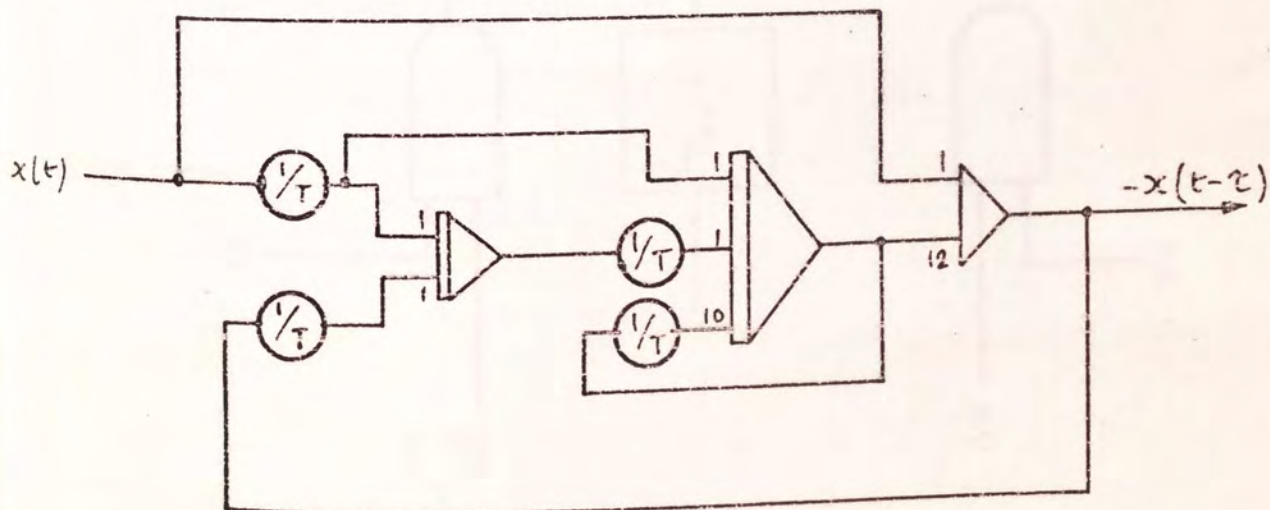
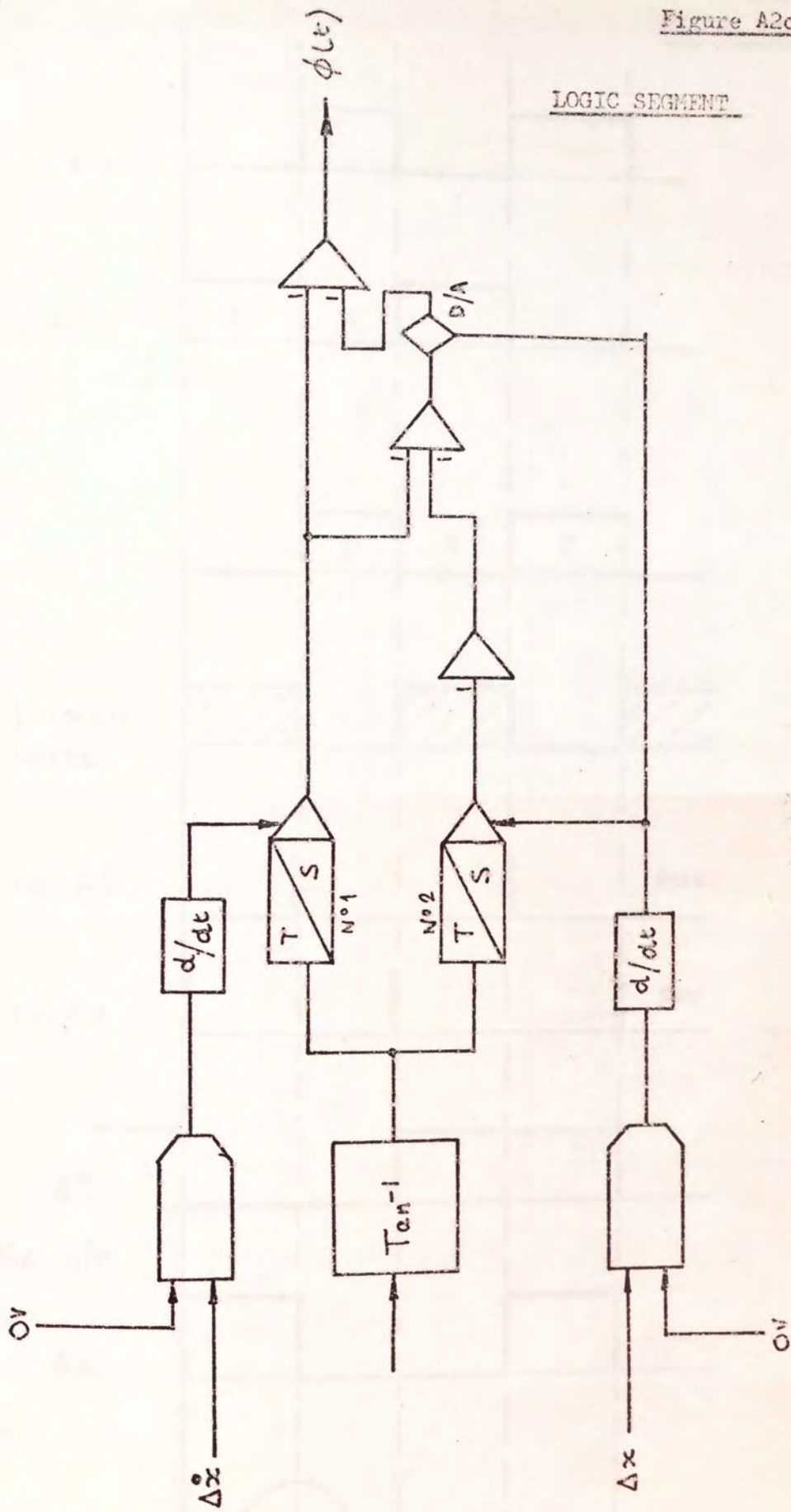

Figure A2c

LOGIC SEGMENT





### Timing Diagram for the Logic Segment

Figure A3a

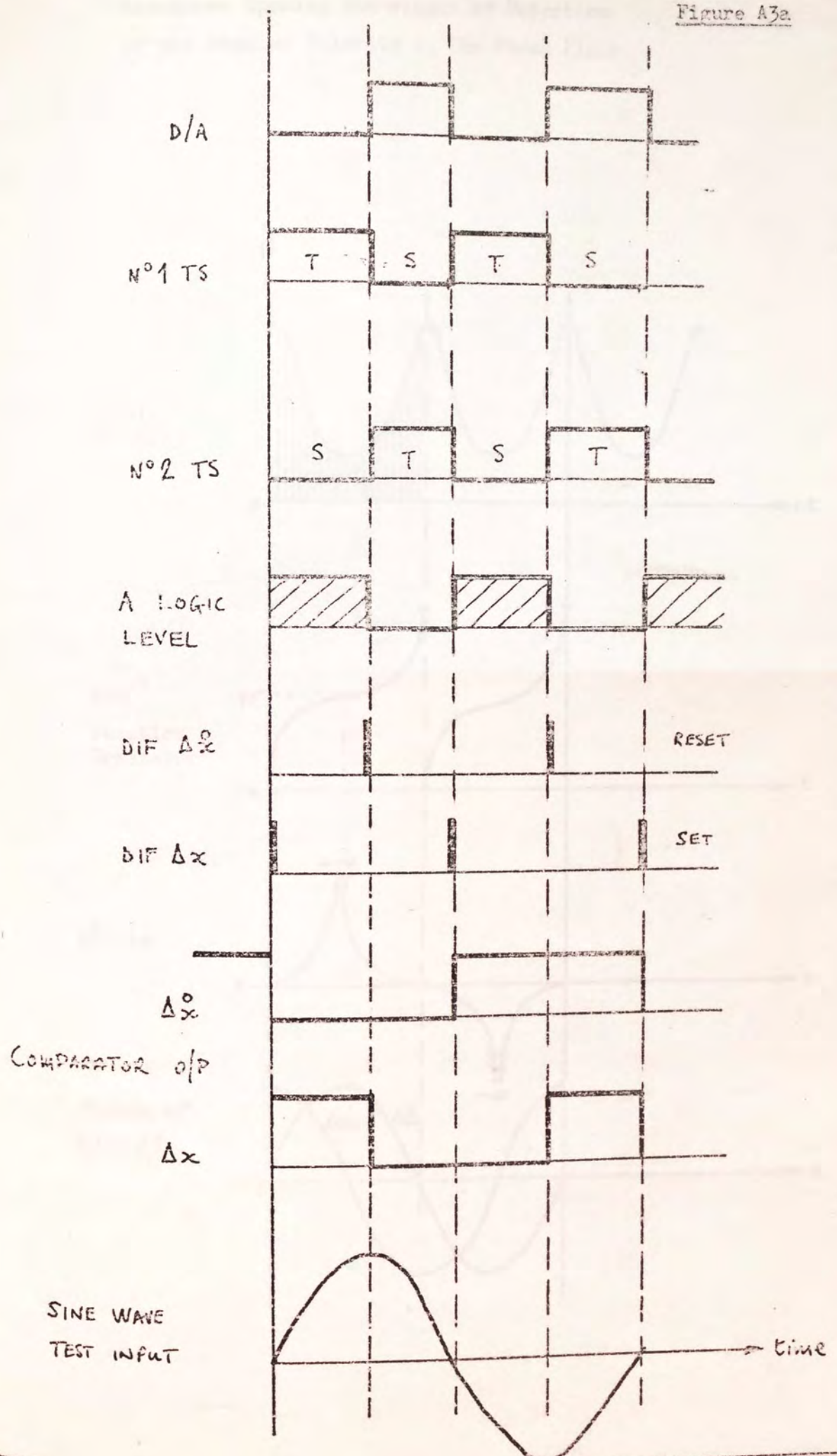

Waveforms Showing the stages of Detection of the Angular Velocity in the Phase Plane

Figure A3b

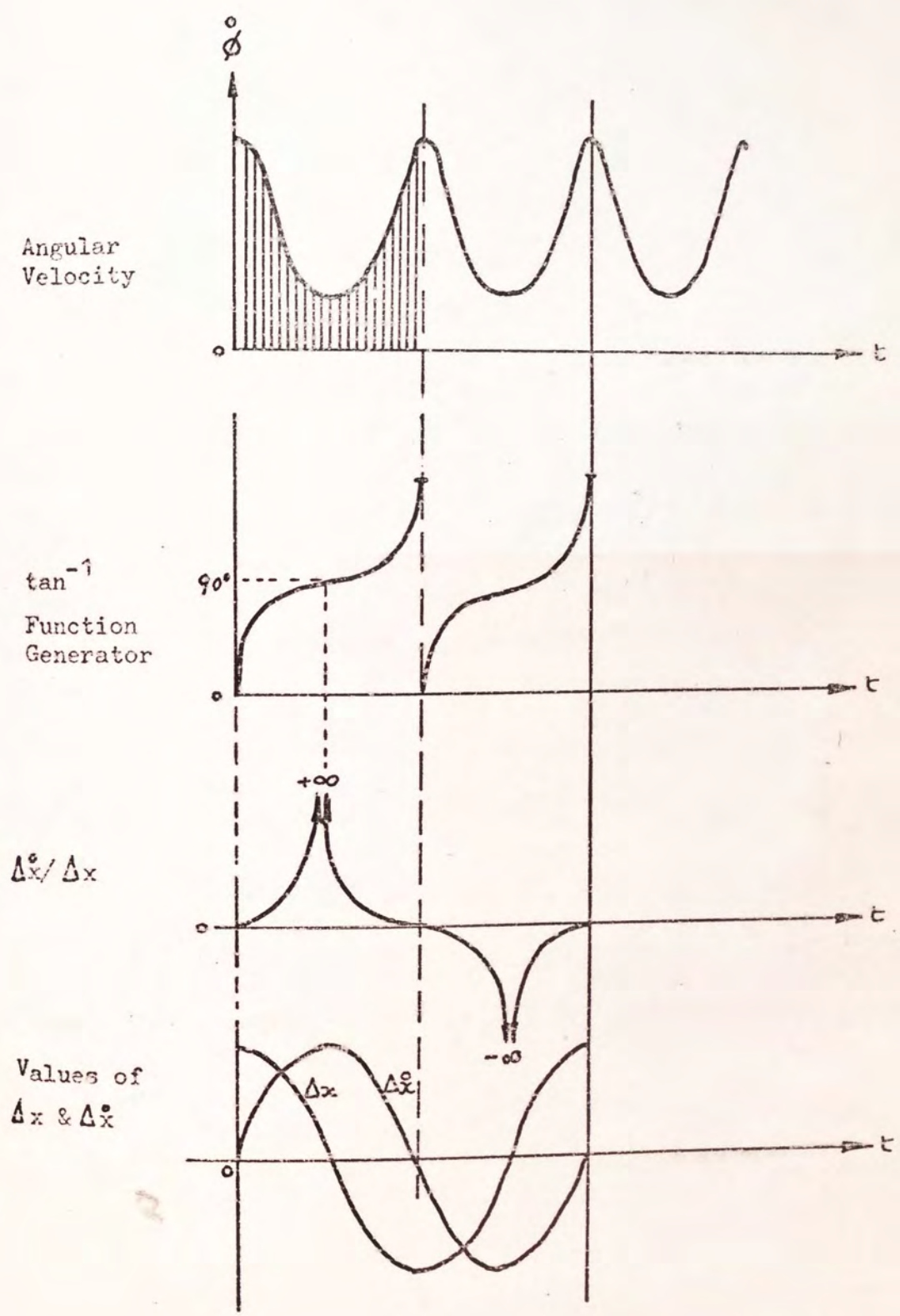



## A P P E N D I X    B

### COMPUTER PROGRAMS

The computer programs contained in this Appendix were written for the ICL 1905 computer and all feature use of the Calcomp Graph Plotter.

The programs are written in the ICL 1905 version of ALGOL 60 and the run time, cost per run and storage 'in core' required are shown in the program listing. The Spectrum Analysis programs, because of their size were written in overlay. As a result there appear labels like 'procedure' PART 1 and BLOCK 4; these refer to the block structure and should be ignored when reading the program.

In all 23 analysis programs were written. The four that are presented here were used to generate the descriptions which were used in Part II to analyse the Vibration and Task data. Subsequent to their use for this thesis the programs were converted to run on the Rank Xerox Sigma 7 and built into a general purpose Waveform Analysis Package entitled ATWAVE which is now commercially available.

#### Program 'Hanning'

This program computes the Auto Spectrum, Co Spectrum, Quad Spectrum, Gain and Phase Spectrum s within and between waveforms given their auto and Crosscorrelation functions. The parameters to be set are as follows:

Auto 1 or 0; If set at 1 the program computes and outputs the Auto Correlation & Auto spectral functions. If set at 0 it does not. (in Algol the word 'TRUE' can replace 1 since both have the same Boolean value)

Cross 1 or 0; If set at 1 the program computes and outputs the Co & Quad Spectra, Crosscorrelation function, Kennedy-Pancu diagram & the Gain and Phase Spectra.



If set at 0 the program does not process or output the between waveform descriptions but does output the auto correlation and Auto Spectrum if and only if the Auto parameter is set at 1.

- SU : This parameter is the magnetic tape speed up ratio, if any, used in the calculation of the Correlation functions.
- N : Is the number of Correlation points in the Correlograms to be read in.
- T : Is the Time Delay increment between adjacent values in the Correlograms.
- TD : Is the Time delay in the Crosscorrelogram (if Known) from the Zero delay ordinate to the first (or max) peak in the Crosscorrelogram.
- P : Is for use in calculating the value of  $R(\text{INF})$  for correlograms which decay to zero ie random waves & which have a distinct peak ( as in the case of the Autocorrelogram at  $= 0$ . P is the number of points of the Auto correlogram over which the value of  $R(\text{INF})$  is to be calculated.
- Z ; Z = 1 calculates the spectral function at all time time delay increments.
- Z =  $\frac{1}{2}, \frac{1}{4}, \frac{1}{8}$  and so on calculates the spectral functions for the first  $\frac{1}{2}, \frac{1}{4}, \frac{1}{8}$  and so on of the spectrum associated with the correlogram.

In the form in which it is presented the program is set up to read in the output from the TMC Correlation Computer.

The Hanning Program calculates the Power Spectral Density Functions at the



special frequencies  $(2J + 1) \cdot 2 / NT$  and the result is output on to paper tape as well as Graph Plotter. An Example of Graphical Output is shown in Figs 2.89-2.94. The Spectral values are Smoothed according to the Hanning principle - hence the label.

#### Program 'Twofive'

Program 'Twofive' is an alternative to the Hanning program in which the Power in the Power Spectral Density Function is calculated in contiguous band widths. The Method is based upon 'A Method of Frequency Analysis' proposed by J.A.Milner in R.A.E.Tech Note No ARM.547.(1954). In this program instead of smoothing the raw spectral values the Auto Correlation function is itself modified by multiplication by  $\text{Sin}X/X$  otherwise the two programs are the same except that the Graphical output of the Milner program labelled 'Two five' reflects the fact that Power is calculated in bandwidths. Examples of output from 'Twofive' are shown in Figs 2.53-2.64.

#### PROGRAM DISPLAY

This program was used to plot the Isometric projections of the Spectral functions. The parameters to be specified are as follows:

N : Number of individual graphs to be plotted.

H : Number of numbers associated with each individual graph.

C : Is the angle of the graph ( degrees) from the abscissa to the base of the plot.

T : Is the basic Time Delay increment in the Correlograms used to calculate the Power Spectrum.

These to be set only if graph to be plotted is a Spectrum.

SU : Is the magnetic tape speed up ratio which was associated with calculation of the Correlograms.

The values T & Su are used to scale the frequency axis when the graph to be plotted is a spectrum.

If you have discovered material in AURA which is unlawful e.g. breaches copyright, (either yours or that of a third party) or any other law, including but not limited to those relating to patent, trademark, confidentiality, data protection, obscenity, defamation, libel, then please read our [Takedown Policy](#) and [contact the service](#) immediately



ON WAVEFORM ANALYSIS, THE ADAPTIVE TASK  
TECHNIQUE AND THE EFFECT OF VIBRATION  
ON MANUAL CONTROL SKILL

A Thesis Submitted by

Graham Douglas Whitehead MSc.

For The Degree

THESIS

159.944

184897 29 MAR 1978 WHI

DOCTOR OF PHILOSOPHY

University of Aston in Birmingham

December 1972